

Joint Distributed Engineering Plant(JDEP)

June 2002



Steve Bridges
JITC JDEP Division Chief





JDEP Defined



“ The JDEP program was established as a DoD-wide effort to link existing service and joint combat system engineering and test sites (including design activities, software support activities, test and evaluation facilities, training commands, and operational units). JDEP is designed to improve the interoperability of weapon systems and platforms through rigorous testing and evaluation in a replicated battlefield environment. “

[DPG Update FY 2002-2007, Guidance, p.112]



The Big Idea



- Doctrine and operations are increasingly dependent on **Joint SoS to support networkcentric warfare**
- This demands **new approaches to SoS development**, integration, test and assessment
- **JDEP** addresses this need by providing users with the means to create SoS environments by linking existing, distributed system HWIL assets
- Assets, built and used for individual system development and test, are **shared and applied** in different configurations to address SoS
- JDEP supports users to identify the right resources, to configure resources to address **interoperability issues**, providing access to common reusable assets (networks, security devices, scenarios, etc.)



JDEP Policy Context

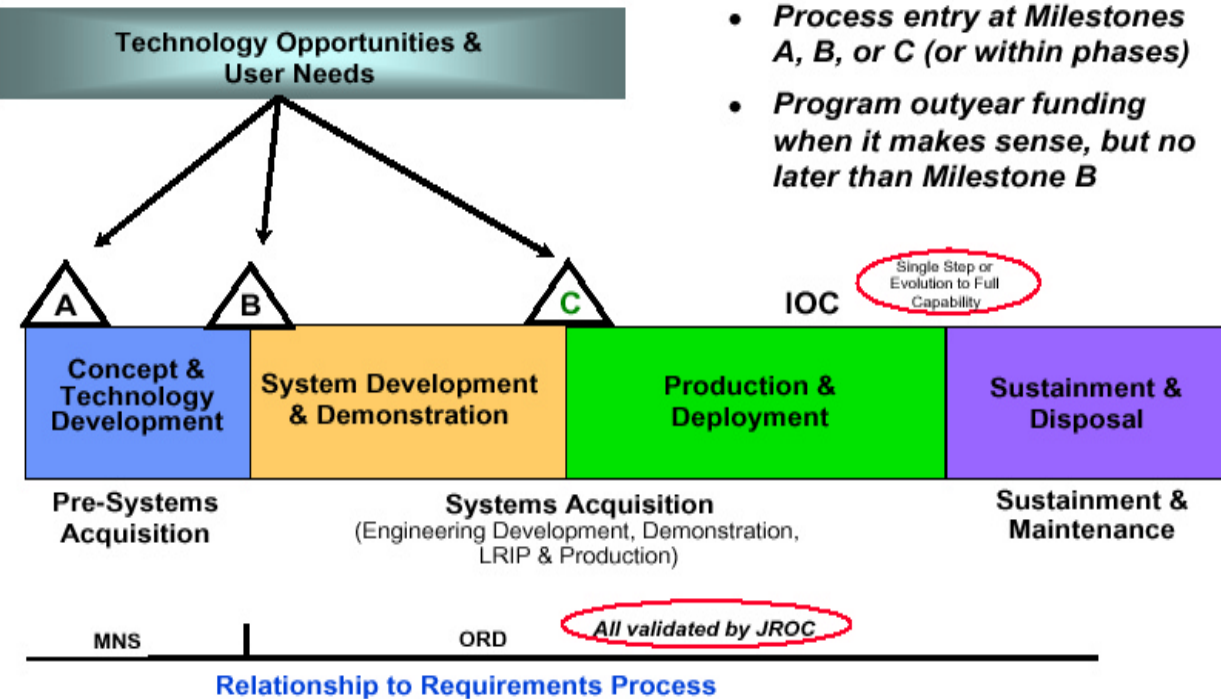

- *Process entry at Milestones A, B, or C (or within phases)*
- *Program outyear funding when it makes sense, but no later than Milestone B*

• 5000.1 Acquisition Process

• CJCSI 3170.01A Requirements

- Interoperability Key Performance Parameters (KPPs)

• CJCSI 6212.01B

- C4ISP Plans

• DODI 4630

- Interoperability of IT and NSS
- Joint I&I Process



JDEP Major Milestones

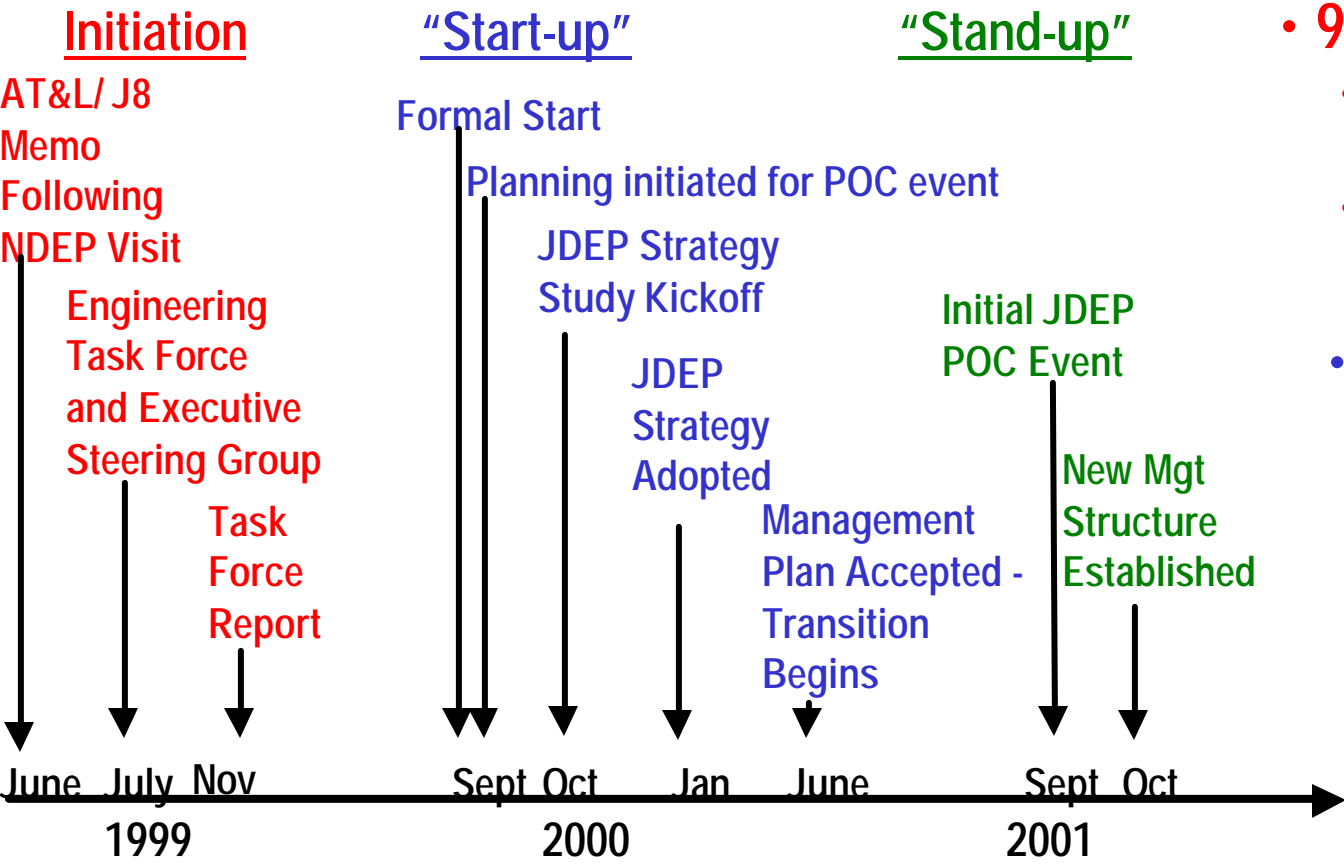

- **99 Memo creates JDEP**
 - Formed Steering Group & Engineering Task Force
 - Adopted initial plan for JDEP implementation with JTAMD
- **Sept 00 Program Start**
 - JTAMD Interim Manager
 - POC Event Planning
 - JDEP Strategy Adoption
- **Current Status**
 - POC Event Executed
 - New Management Structure In Place
 - FY02 + Planning



Purposes of JDEP

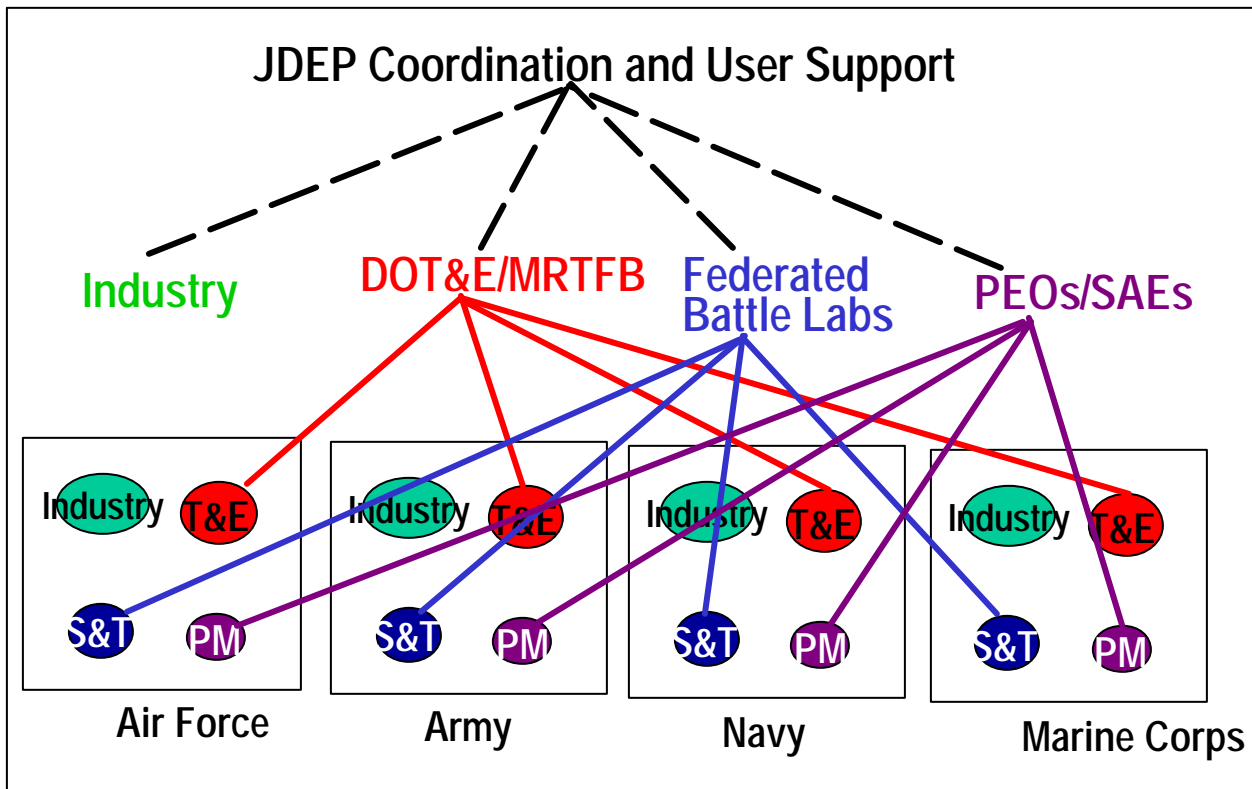

- **JDEP will support three types of users**

- **Developers** to engineer interoperability into systems
- **Testers** to test and evaluate interoperability among systems
- **War fighters** to assess operational capabilities of forces

- **By providing technical support to identify, access, and configure HWIL and SWIL federations of SoS to meet users' needs**



JDEP Vision



Improve the interoperability of weapon systems, platforms, and C2 by providing users the capability to create environments to support engineering, integration, testing, and evaluation in a replicated battlefield environment, leveraging service and joint combat system engineering and test sites.



JDEP Mission



Create a capability to federate DOD/Industry laboratories, test sites, and facilities to address and resolve warfighter, systems developer, and tester interoperability and integration issues by:

- **Supporting users to identify, access, and federate HWIL, simulated, and range-based systems, and supporting tools, under a set of common standards and procedures**



Current JDEP Goals



- **Support air and missile defense user federations**
- **Initiate JDEP process implementation to refine products and services to meet both existing and projected customer needs**
- **Establish standards-based technical framework to support cost-effective configuration of JDEP federations and reusable infrastructure investments**
- **Create awareness of JDEP capabilities within system development, testing, and warfighter communities**
- **Expand JDEP use to other customers/areas**



JDEP Management Structure

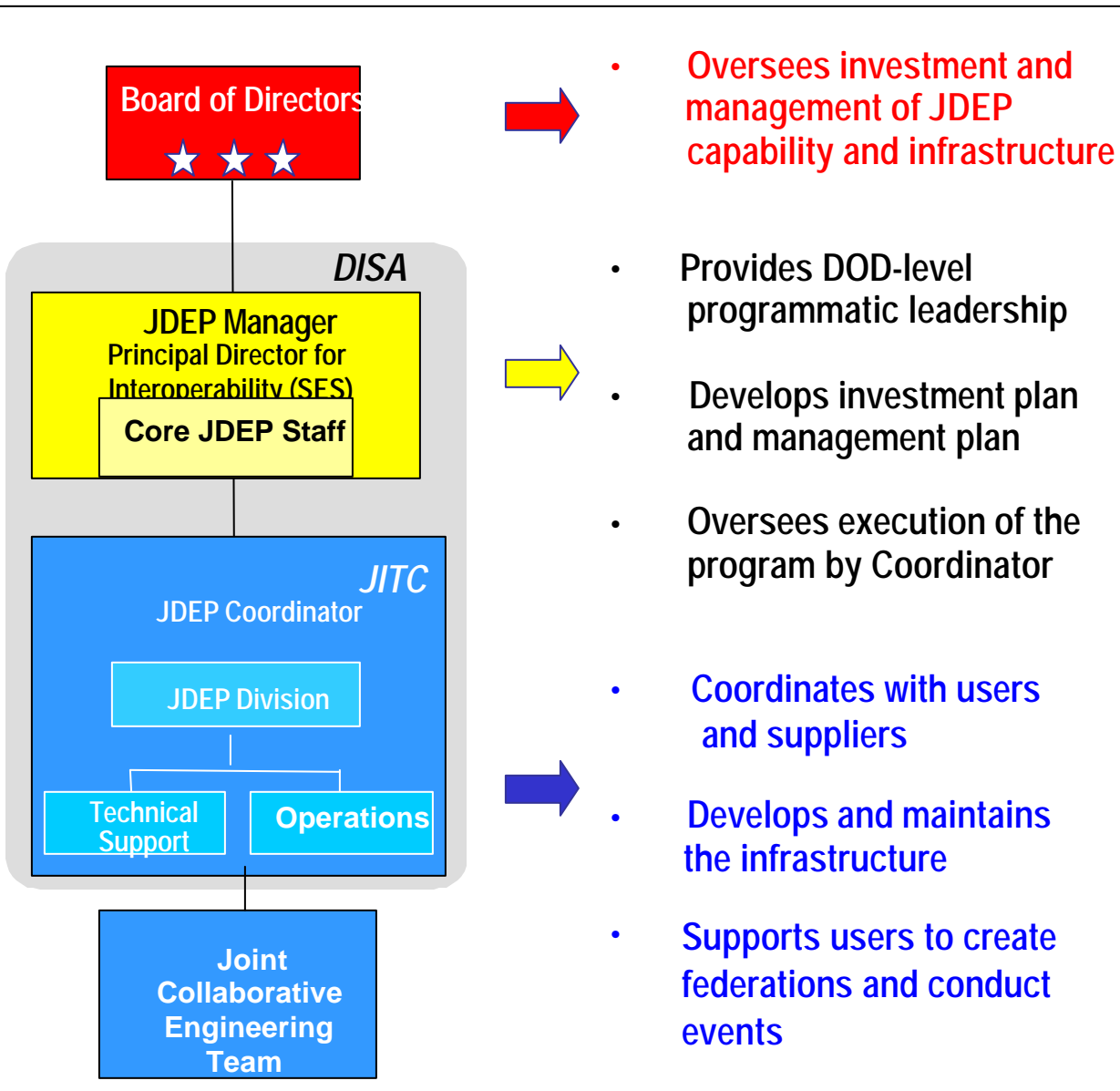

- Oversees investment and management of JDEP capability and infrastructure
- Provides DOD-level programmatic leadership
- Develops investment plan and management plan
- Oversees execution of the program by Coordinator
- Coordinates with users and suppliers
- Develops and maintains the infrastructure
- Supports users to create federations and conduct events

- **Single management structure supporting multiple user communities**
- **Users (PMs, test agencies, etc) work within their existing structures to conduct events with JDEP support to meet their needs**



JDEP Management Approach



- **JDEP Management: DISA Director for Interoperability**
 - Responsible for Policy, Prioritization, and Funding development
 - Area management coordination, Plans & Policies coordination, Life Cycle Management, scheduling & event oversight
 - Provide DOD level organizational programmatic leadership, advocacy and oversight to investment and conduct of JDEP
 - Develop investment plan and management plan
 - Oversee execution of the program coordinator (JITC)

- **JDEP Technical Support and Coordination: JITC**
 - User Oriented/Focused
 - Manage and organize multiple events each year
 - Technical organization, teaming with JDEP stakeholders to enable the cross mission area infrastructure development plan for JDEP
 - Coordination and technical Support Organization
 - ◆ Selects facilities for events, provides technical support
 - ◆ Infrastructure management, standards compliance, configuration control, test coordination (planning, execution, and DMAP)
 - Develops and maintains the infrastructure
 - Supports conduct of events



Federations Based on Technical Framework

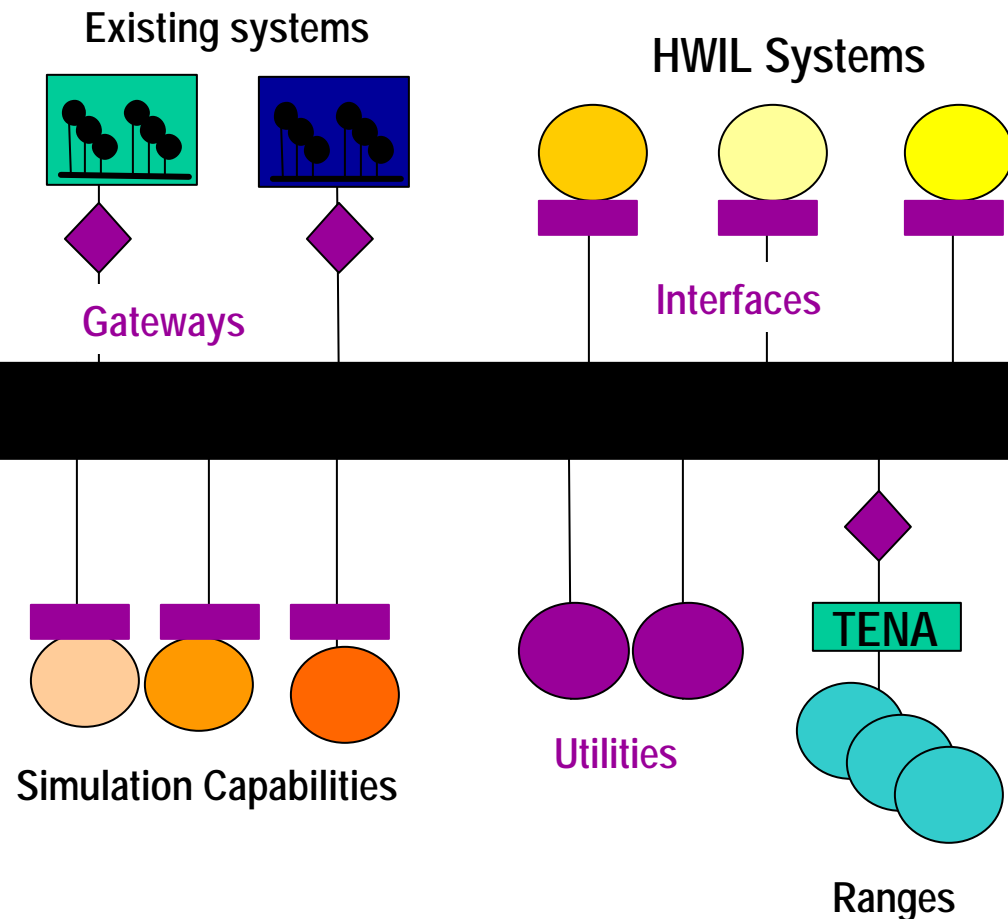

- JDEP will support federating of capabilities on a standards-based (COTS) **common infrastructure**
- Addresses the 'n-way' issue, different systems can interact into a **core standards-based federation**
- **Gateways** can be 'productized' and managed as JDEP assets
- New systems can be added to the core with support by JDEP **interfaces**
- **Utilities** (data collectors, viewers, mgt tools) can be used with federations with different mixes of components



Simulations as a JDEP Component Type



- **JDEP** was created specifically to address HW/SWIL SoS support
- **Simulated elements** are a critical element of JDEP federations representing aspects of the environment which cannot be ‘live’
 - Elements of the HW/SWIL systems of interest (e.g. platform movement) which cannot be represented live
 - Area-wide effects (e.g. effects of natural environment, communication or electronic warfare)
 - Threat systems
 - Blue systems, which need to be present to meet the needs of the event but do not require HWIL
 - Digital systems representations, early in development process
- As with HWIL/SWL, JDEP will **reuse simulations** available from the Agencies and Services



JDEP FY01 Proof of Concept Event



AWACS
30/35 w/RSIP
Boeing **Seattle**

E-2C Group II
SSC -
San Diego



AEGIS Ships
B/L 5.3.7.2
NSWC DD
ATRC/DOC



PATRIOT
PDB 5
Huntsville

- Initial planning based on
 - Use of NDEP process to produce 'Caps and Lims'
 - Reuse NDEP network, scenarios, data collection and analyses
 - Limited funding
- SIAP SE selected customer
 - Required rethinking
 - Placed constraints on event due to schedule and funding

- Event objectives
 - Characterize performance against with SIAP metrics
 - Identify added capabilities needed for SIAP follow-up analysis
 - Develop JDEP process
- Event was executed in September; analysis underway



JDEP FY02 Applications



- **Technical Pilot implementation**
 - Time Sensitive Targeting Testbed

- **FY02 AMD Applications**
 - **SIAP -- JCoCaC Top Priority**
 - ◆ Address SIAP Critical Experiments
 - **KTAIP (Now MSCT)**
 - ◆ Support assessment of correlator with US systems



Joint TST Test Bed Pilot



TST SIMEX 6 Configuration

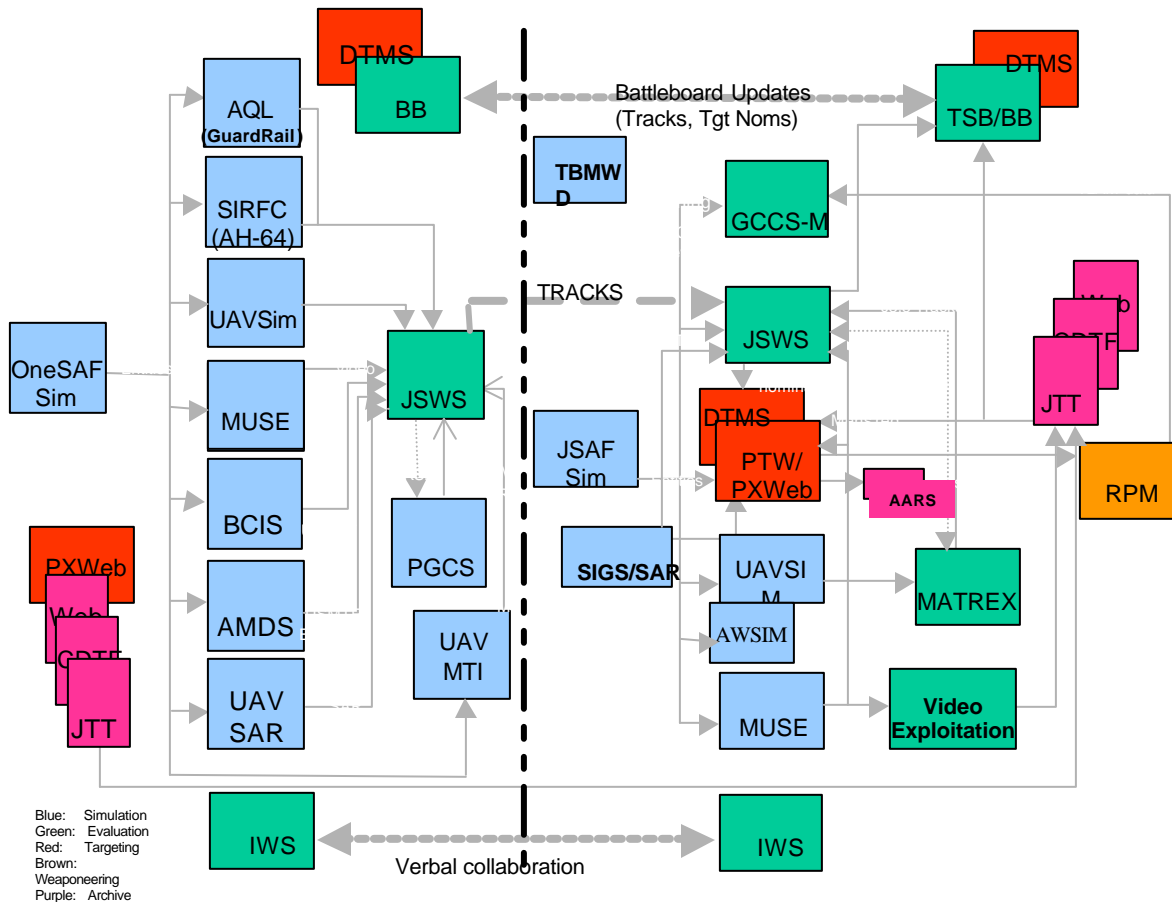

- **Linked Service Labs to address joint TST issues**
 - Navy Strike Cell
 - CECOM I2WD
 - AF ESC SWIFT Lab
- **Current configuration is a direct integration of the capabilities available at sites**
 - Opportunity to examine viability of JDEP technical framework, migration approaches, issues and costs, and to assess advantages



MSCT Event

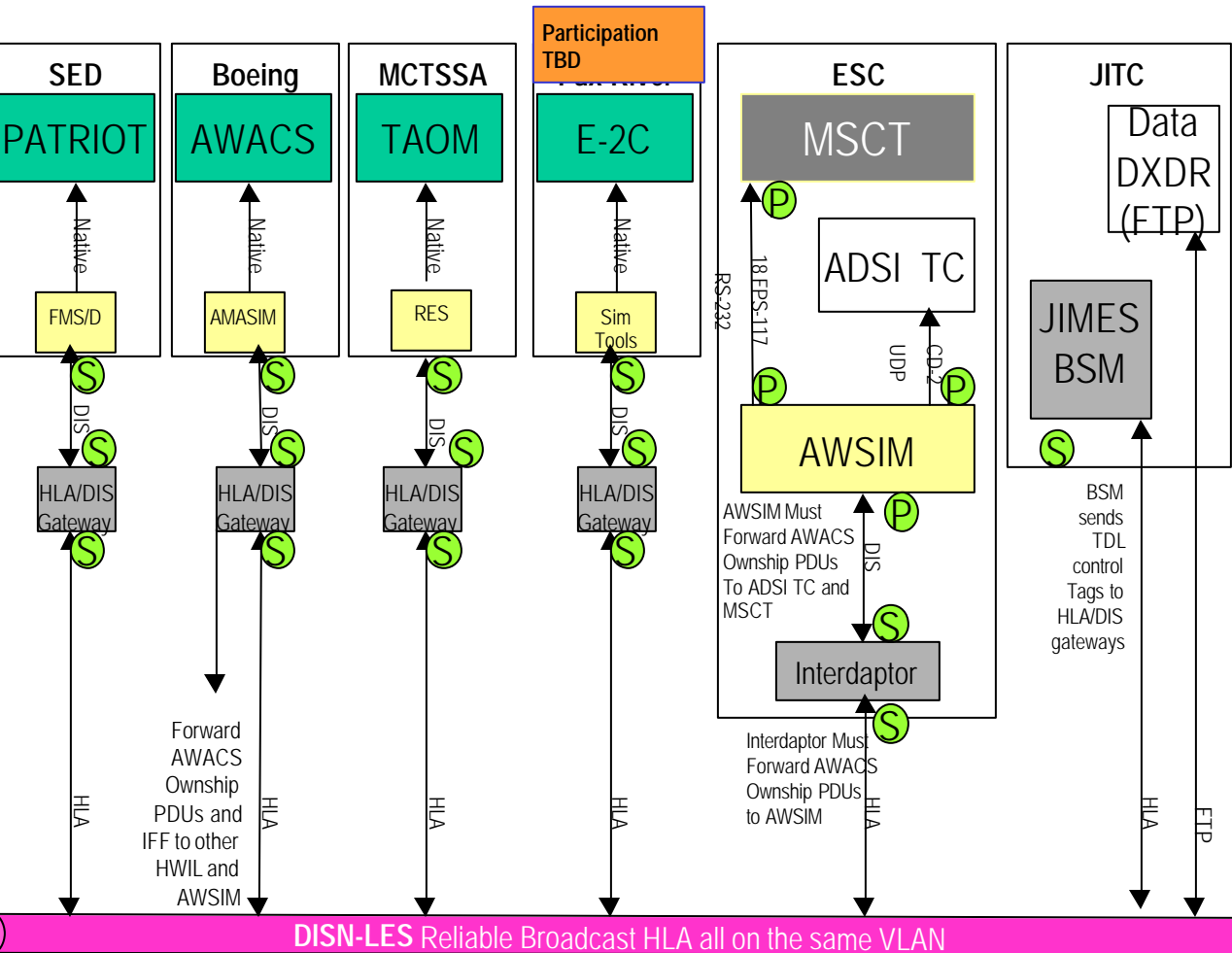

- Originally called 'KTAIP'
- Led by AF ESC
- Supplement current simulation approach with selected HWIL representations of Blue BMC3 systems to
 - Reduce risk
 - Validate simulations
 - Add operators to support quantified operational benefits

Primary and Secondary Data collection Points



SIAP SE is the primary air defense JDEP customer

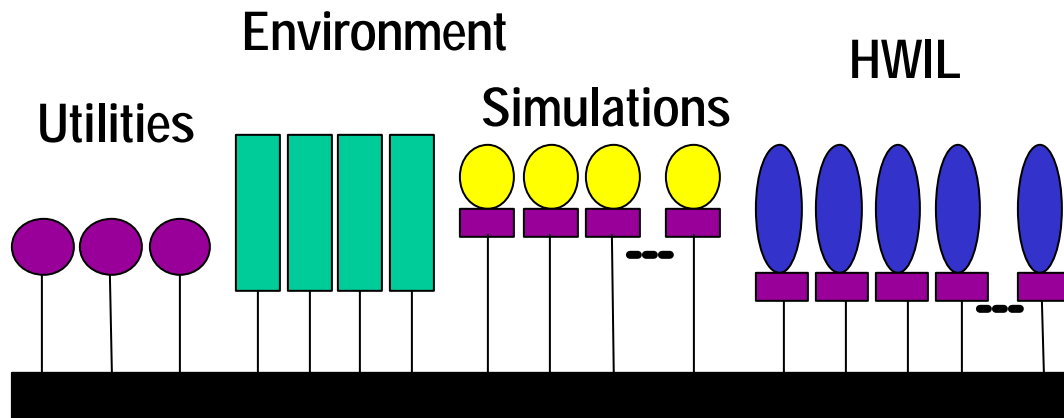

JDEP supports the SIAP SE process by addressing SIAP critical experiments, applying SIAP metrics and common reference scenario

• FY02 Objectives

- Conduct experiments to begin to address SIAP Block 1 issues
 - Time synchronization and sensor data registration with Patriot and E2C
 - Quantify bias effects on track quality and correlation
- Begin creating set of reusable federation components to meet SIAP engineering needs

• Follow-on steps in FY03

- Incrementally add HWIL with updated sim-stim (AWACs, AN/TPS-59, AEGIS, F15-C, CRS) and execute events to address bias effects



Summary



- **Initial focus on JTAMDO and SIAP SE mission area applications is supporting users**
 - **JTAMDO Proof of Concept Completed Sep 01**
 - **MSCT Event scheduled for Sept '02**
 - **SIAP SE Events through Late Summer-Fall'02**
- **JDEP is growing to provide a DOD-wide capability to support system of system engineering**
- **Simulations are important components of JDEP federations**