

# *Aviation and Missile Research, Development, and Engineering Center*



## *The Future of Small Missiles*



*Presented by*  
***Dr. James C. Bradas***

*April 2005*

*Associate Director for Missile Technology and Director, Weapons Sciences Directorate*

*Aviation and Missile RD&E Center  
U.S. Army RDECOM*

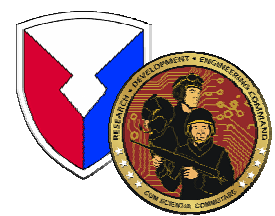

# ***First, A Bit of History***



- ***Many of the Army's Current Inventory of Tactical Missiles Were Designed or Envisioned During the Cold War***
- ***Many Tactical Missiles Were Designed to Defeat Main Battle Tanks ( TOW Family, HELLFIRE/LONGBOW, Javelin )***
- ***Guidance Techniques Have Evolved –***
  - TOW – Command Guidance ( 1960's )***
  - HELLFIRE – Semi-Active Laser Guidance ( 1970's )***
  - LONGBOW – LOBL / LOAL RF Active Terminal Homing ( 1980's )***
  - Javelin – LOBL Fire-and-Forget Passive Terminal Homing ( 1990's )***
  - Joint Common Missile – Tri-Mode Seeker Terminal Homing ( 2000+ )***

***Truly Autonomous, “Fire-and-Forget” Weapons Able to ID Targets  
Not Yet Do-Able  
Without Significant Risk of Fratricide / Collateral Damage***

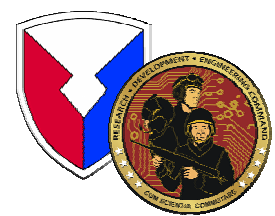

# How Successful ?



- ***Desert Storm I***  
***HELLFIRE Viewed as Very Successful Although “Overkill” on “Highway of Death” Retreat from Kuwait***
- ***Operation Enduring Freedom ( Afghanistan )***  
***PREDATOR UAV + HELLFIRE Combination Very Successful***
- ***Operation Iraqi Freedom***  
***HELLFIRE with Mod K Warhead***  
***TOW 2A / TOW “Bunker Buster” Warhead***  
***Javelin – Battle of Debecka Pass by Special Forces***

***10 – 40 Year-Old Technology Proven Very Effective***

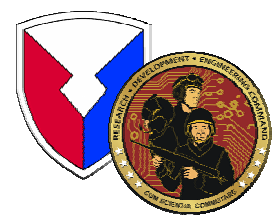

# As Far as Army S&T Is Concerned - We Want to Get There -



## Today's Tactical Missile Capability

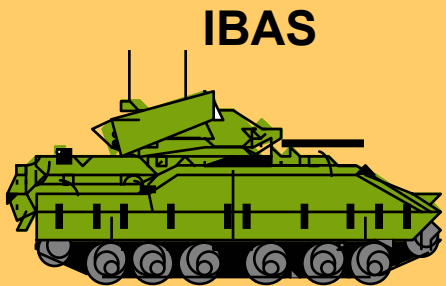

IBAS



TOW 2A

ITAS

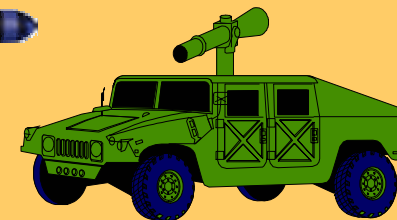

TOW 2B

TOW Bunker Buster

AT4



Javelin

**The Question Is – Where Are We Going?**

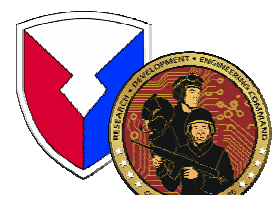

# EVOLVING ARMY TRANSFORMATION

*Current to Future Force – Accelerate fielding of select Future Force capabilities to enhance Effectiveness of Current Force, Army Transformation is part of constant change.*



## CURRENT

Countermeasures

Multi-mode Seekers

IM Warhead & Propulsion

ATA Algorithms

Multi-mode Warhead

Controllable Thrust Propulsion

FUTURE JAVELIN



## FUTURE

CKEM

*Developing the Future Force while Simultaneously Spiraling Future Capabilities into the Current Force -- "The Way Ahead"*

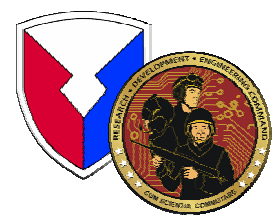

# Is This Where We're Going?



## Future Combat Systems (FCS)

**NLOS-LS  
PAM & LAM**

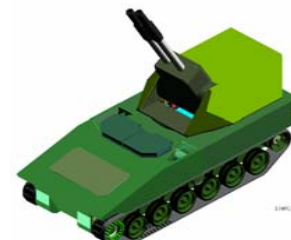
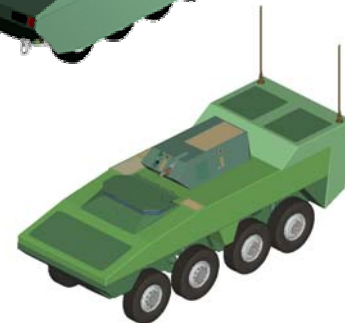
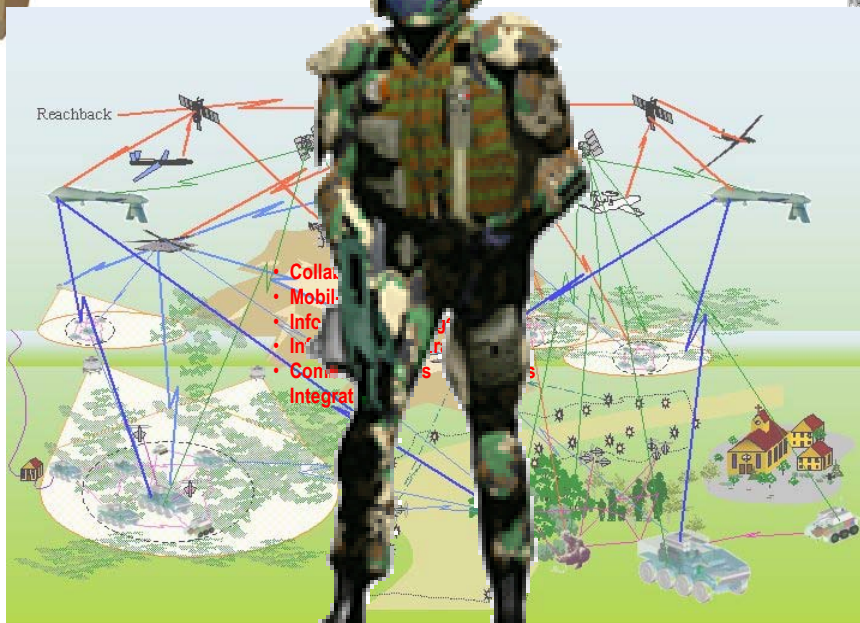
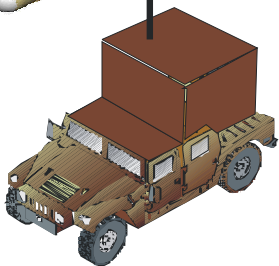
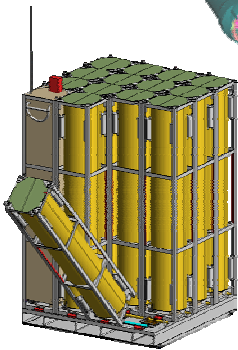
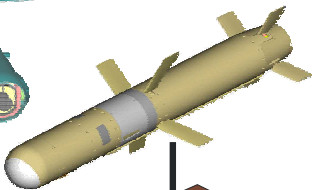

**CKEM**



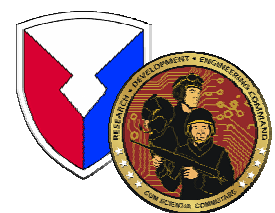

# DoD View of Changing World Threat



## IRREGULAR

Those seeking to erode U.S. influence and power by employing unconventional methods, such as:

- Terrorism
- Insurgency
- Civil War
- Emerging concepts such as “unrestricted warfare”

**Likelihood:** very high

**Vulnerability:** moderate, if not effectively checked



## CATASTROPHIC

Those seeking to paralyze U.S. leadership and power by employing weapons of mass Destruction or WMD-like effects in surprise attacks on symbolic, critical or other high-value targets, such as:

- Sept 11, 2001
- Terrorist use of WMD
- Rogue missile attack

**Likelihood:** moderate and increasing

**Vulnerability:** unacceptable; single event could alter American way of life



More likely

Less likely

Lower vulnerability

Higher vulnerability

## TRADITIONAL

Those seeking to Challenge U.S. power by military operations, such as:

- Conventional air, sea and land attacks
- Nuclear forces of established nuclear powers

**Likelihood:** decreasing (absent pre-emption) due to historic capability-overmatch and expanding qualitative lead

**Vulnerability:** low, if transformation is balanced



## DISRUPTIVE

Those seeking to usurp U.S. leadership and Influence by employing breakthrough capabilities, such as:

- Sensors
- Biotechnology
- Miniaturization on the molecular level
- Cyber-operations
- Space
- Directed-energy and other emerging fields

**Likelihood:** low, but time works against U.S.

**Vulnerability:** unknown; strategic surprise puts U.S. security at risk



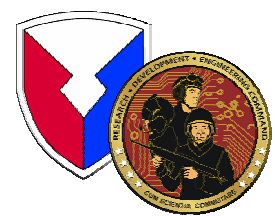

# NLOS-LS



## Networked Lethality – Very Dependent on Networked Sensors

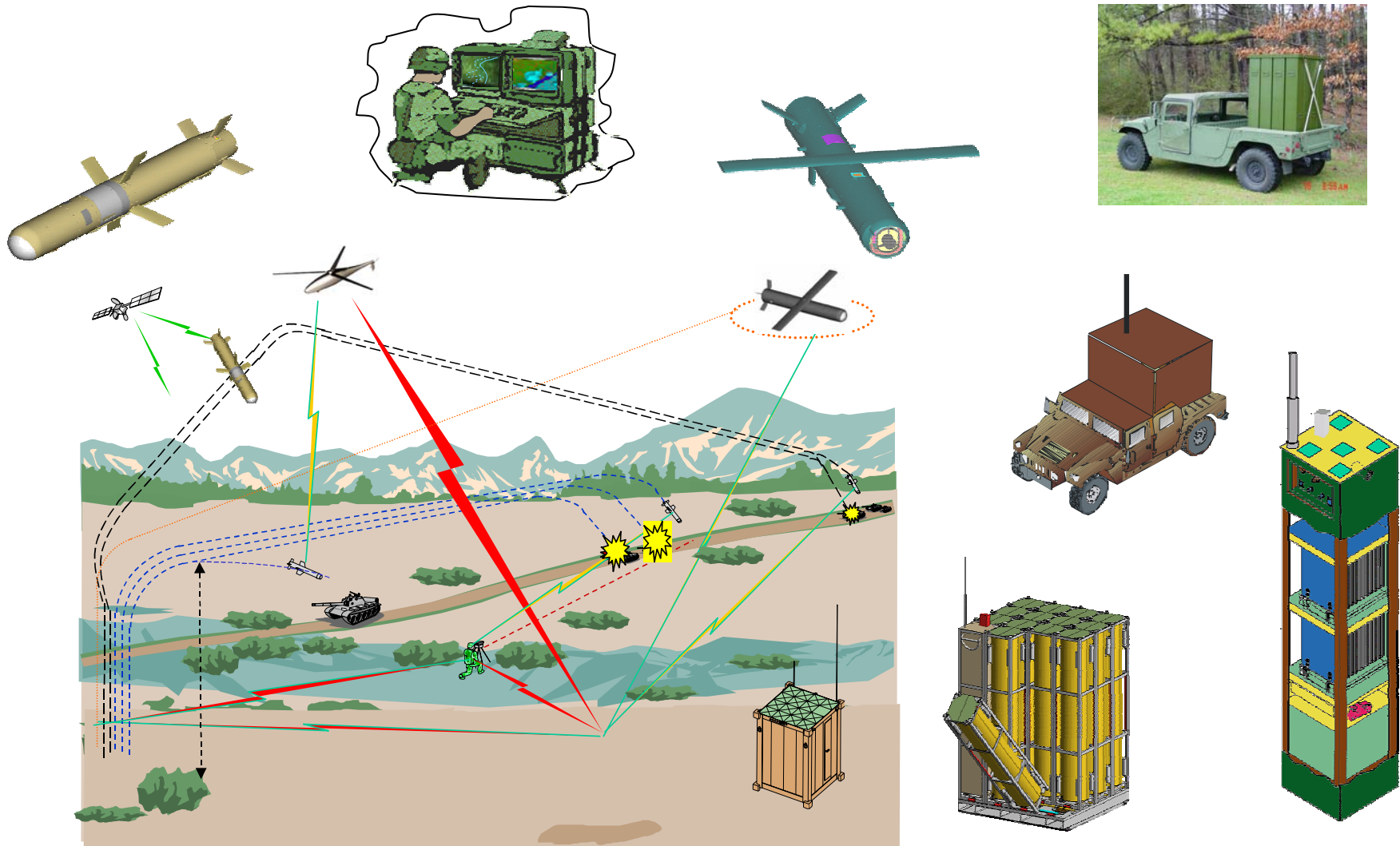



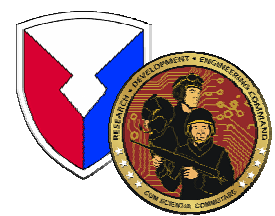

# Precision Engagement Options: From Sledgehammer to Scalpel



**Joint Air to Surface Strike Missile (JASSM)**  
2250 pounds, 14 Feet Long  
**Big Platforms**



**Hellfire Longbow**  
108 Pounds, 5.75 Feet Long  
**Medium/Small Platforms**



**TOW**  
50 Pounds, 4 Feet Long  
**Crew-Served**



**Javelin**  
35 Pounds, 3.5 Feet Long  
**Manportable**

## The 21<sup>st</sup> Century Missile

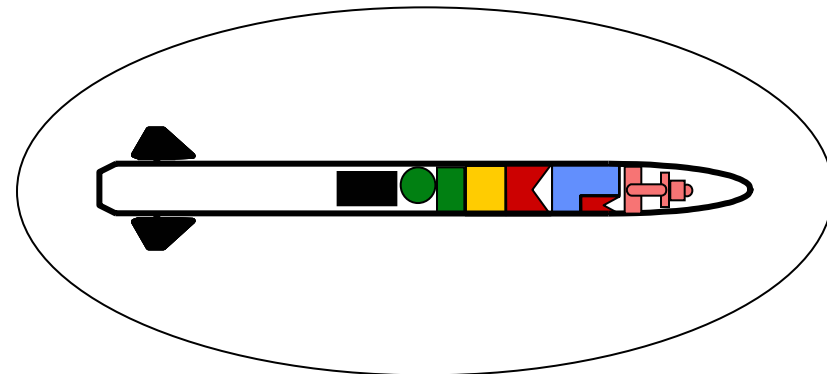

- **How Small?**
- **How Much Range?**
- **BLOS / NLOS?**
- **What Target Set?**
- **How Autonomous?**
- **How Much Will It Cost?**



# Target Sets Are Changing



**From This -**

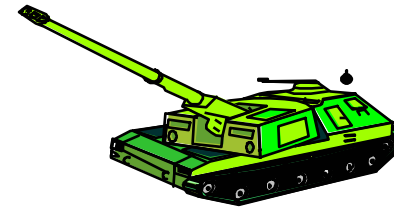
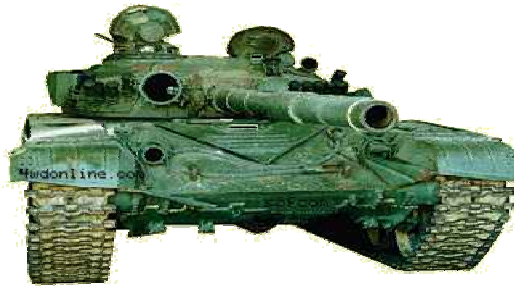
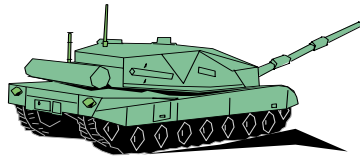

**To This -**



**Light Armor**



**Earth and Timber Bunker**



**8" Reinforced Concrete  
and 12" Triple Brick**

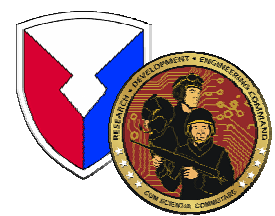

# Survivability is a BIG Focus

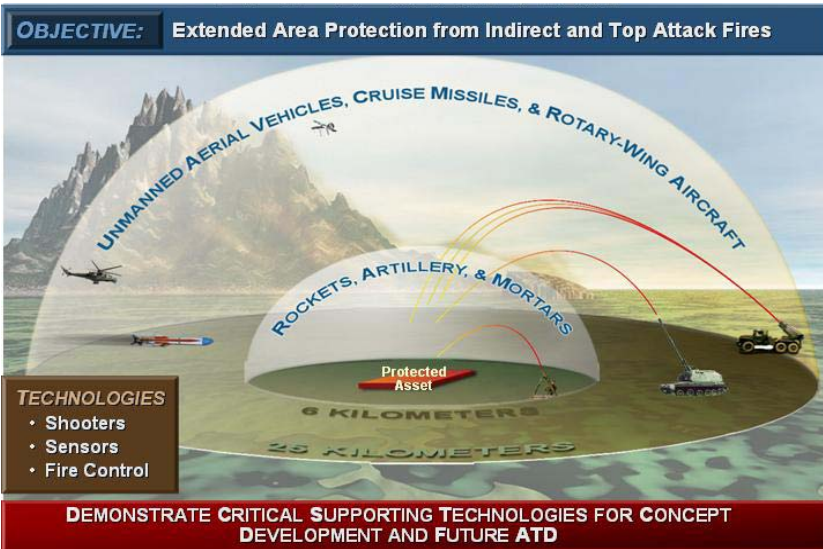

## Extended Area Protection System

- Layered Protection from Top-Attack from Rockets / Artillery / Mortars
- Area Protection vs. Point Protection
- Guided Bullet & Missile Interceptors

## Close-In Active Protection System

- Protection Against ATGMs & RPGs
- Prototypes Being Integrated on Stryker Vehicles
- Next Generation Technology for Smaller & Reduced Fratricide

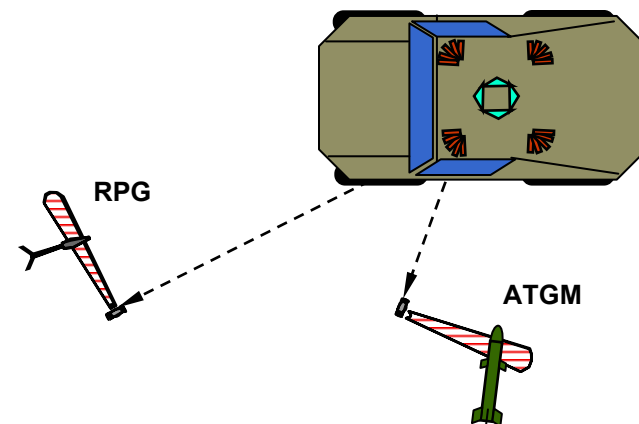



# Key Technology Component Investment Areas

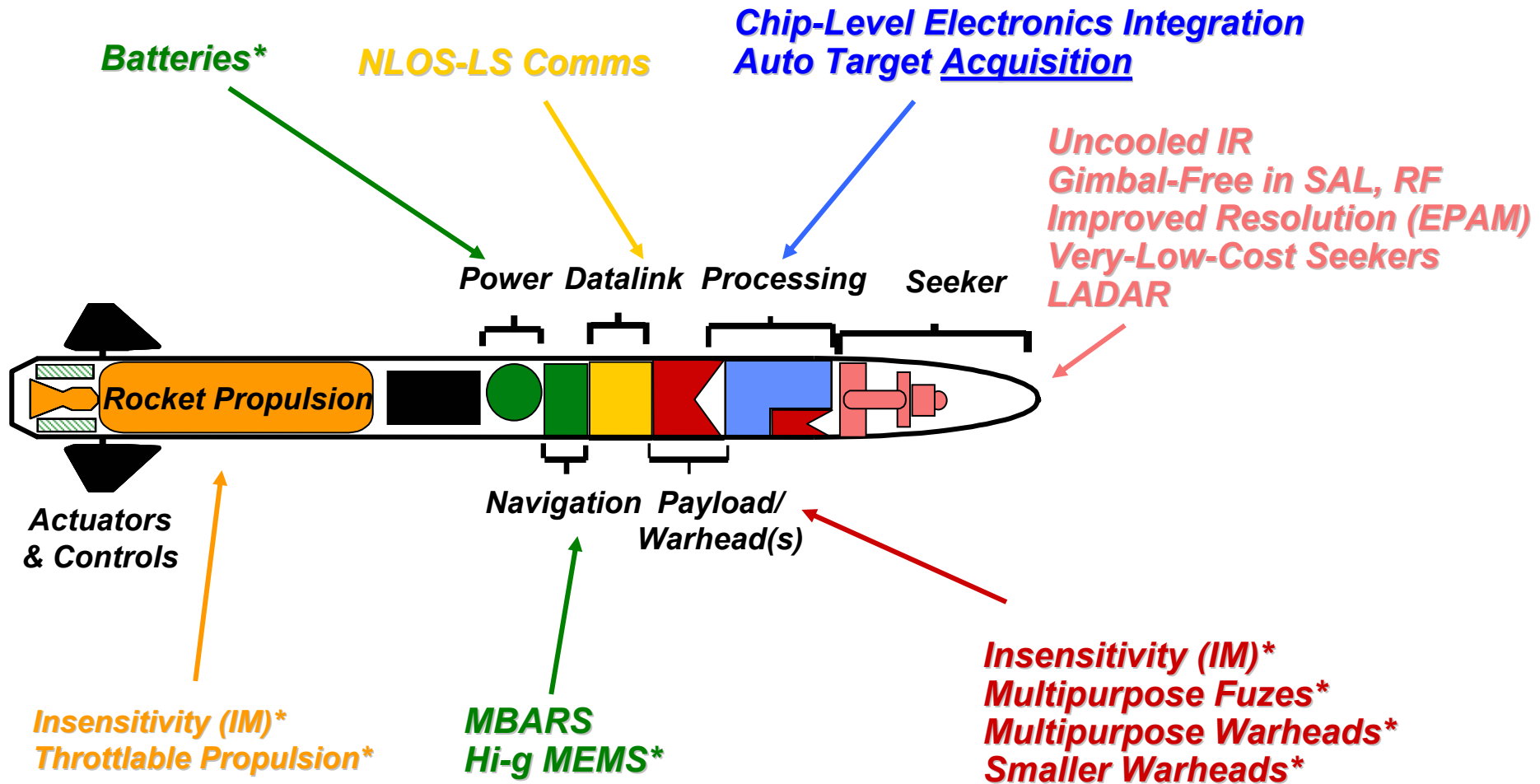

\* Mostly Joint with Army Research Lab and/or Armaments RDEC

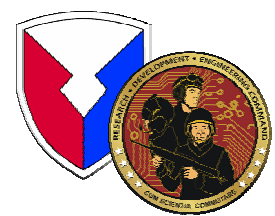

# Trends



***Shorten the engagement cycle (detect, track, identify, assign, engage, BDA)***

- ***Decrease the number of people in the cycle***
- ***Speed the connections between the people in the cycle***
- ***“One shot, one kill” (...or more)***
- ***Perpetually “on station”***
- ***Available (it works “all” the time)***
- ***Few war-winning targets; many war-losing targets. (“regret avoidance” is key)***
- ***Improved target ID / Friend-Foe-Neutral***

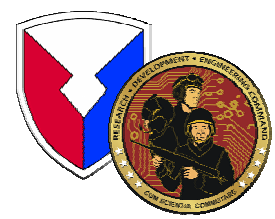

# Key Technology Enablers



- **Reduce Cost (both incremental reductions and fundamentally cheaper guidance technologies)**
  - **Make Technologies “Easier to Build” for More Vendors – Including Less Hi-tech**
  - **Common Components (given a good business case)**
  - **More Open Hardware and Software Architectures, Standards**
- **Reduce Weight and Size**
- **Autonomous Target Recognition / ID / IFF**
- **Improve adverse-weather and MOUT capabilities (IIR, RF, MMW, etc.)**
- **Increase Reliability**
- **Retain few-meter accuracy**

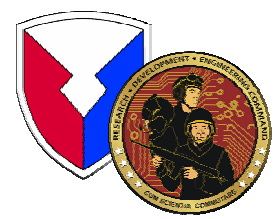

# *The Future of Missiles?*



- ***Multi-Mission***
- ***Multi-Effects Warheads ( Including Non-Lethal )***  
***With Intelligent Sensing / Fuzing***
- ***Beyond Line-of-Sight / Non Line-of-Sight***
- ***Autonomous / Smart***
- ***Cargo Carriers / Payload Deliverers***
- ***VERSATILE***
- ***AFFORDABLE***