

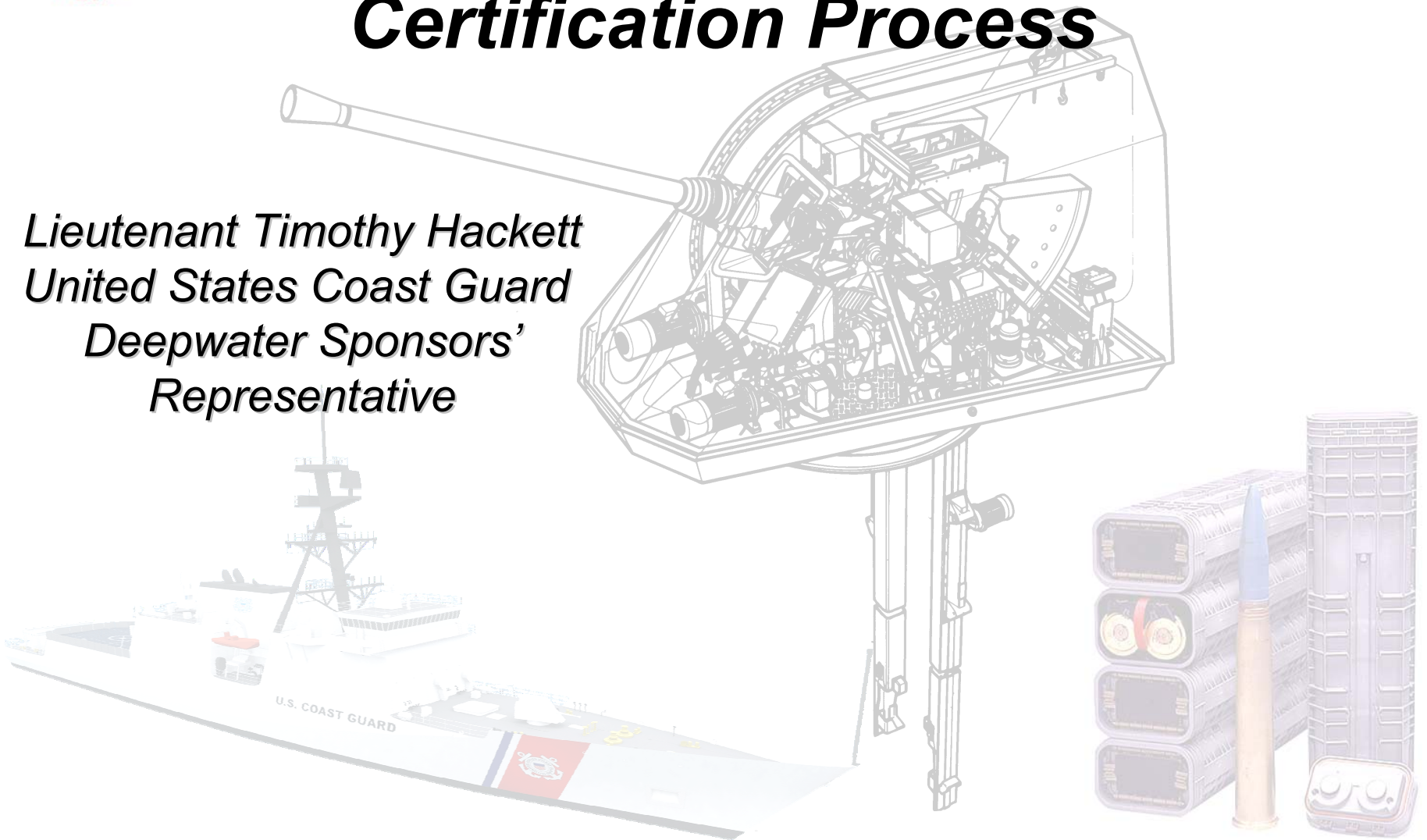

# ***Mk 110 Mod 0 / 57mm Naval Gun & Ammunition Certification Process***

*Lieutenant Timothy Hackett  
United States Coast Guard  
Deepwater Sponsors'  
Representative*





# ***Mk 110 Mod 0 / 57mm Naval Gun & Ammunition***

***Certification Process  
Includes:***



***Review of Deepwater  
Program***



***Engineering Review***



***Logistics Review***



***Gun Test Firing***



***Ammunition Test***



***Teamwork***

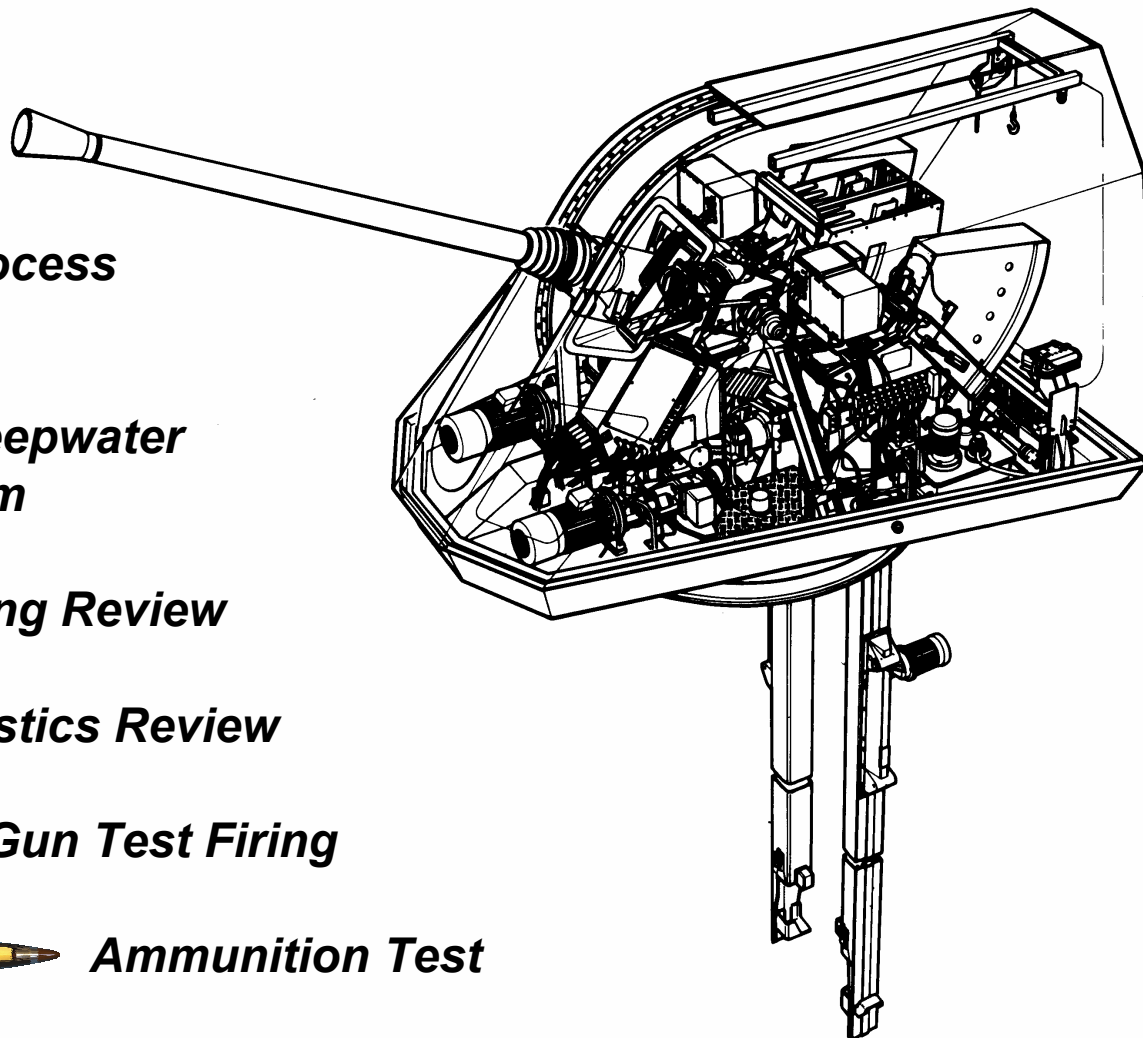

# ***USCG Deepwater Program***



***The Maritime Security Cutter, Large (WMSL) System Performance Specification identifies multiple requirements for limited general defense operations. The requirements include: operating in a low-threat environment, ability to fire warning and disabling shots against targets of interest, engaging surface threats achieving mission kill on high speed coastal patrol craft***



# Engineering & Logistics Review



***57mm Mk 110 Mod 0 Gun in Test Stand @ Louisville, KY***



# 57mm Gun Test Fire Series



Test firings conducted on the Potomac River Test Range



# 57mm Ammunition

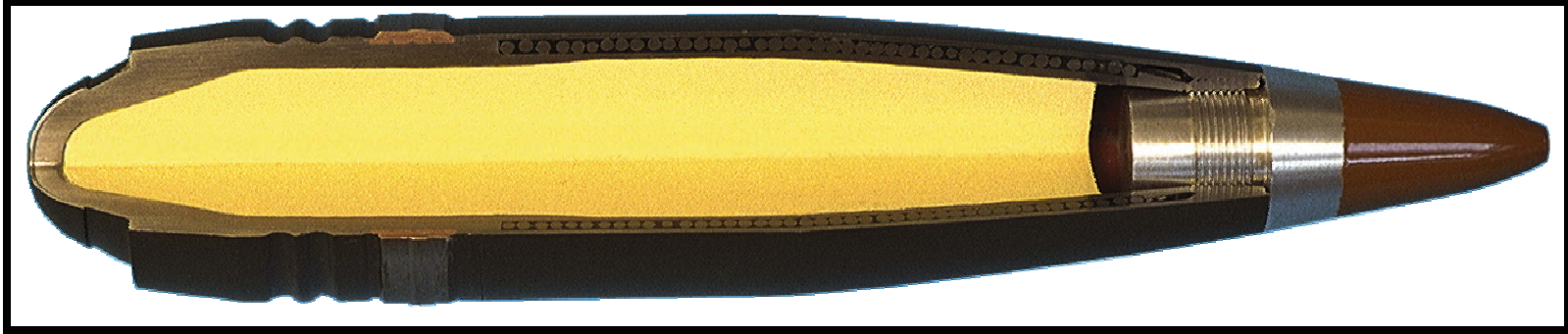



# Ammunition Test





# USCG / NAVSEA Teamwork







# So What Did We Accomplish?

- *Complete understanding of the 57mm Gun*
- *Test Firing of over 2000 Rounds of Ammo*
- *Coast Guard Gunner's Mate Integration Test*
- *USCG / NAVSEA / Industry Teamwork*
- *Ready to present results to the USN's  
Weapon System Explosive Safety Review  
Board (WSESRB) ~ 09 May 2005 ~*



# 57mm Gun Video Presentation

***Traver Sutton***

Naval Surface Warfare Center

Dahlgren

Gun Weapons System Branch

(G-32)

