



DTRA - Modeling and Simulation/Battlespace

**BO05MSB070: Multivariate Decision
Support Tool for CB Defense**

DTRA University Strategic Partnership

Gold Team

Frank Gilfeather, UNM

October 26, 2005



CB Defense Decision Support Tool

Purpose:

Provide an expert decision-support system to assist decision makers in allocating Science & Technology (S&T) research funding to reduce the threat and consequences of CB attacks on critical assets

- *Troops in the field*
- *Main operating bases (MOBs)*
- *Warships*
- *Embassies*
- *Ports*
- *Commands*



*Acknowledged as a difficult problem with great potential,
and with no clear solution*



CB Defense Decision Support Tool

University Partnership Team

UNM – Frank Gilfeather, Thomas Caudell,
Panaiotis, Tim Ross, Mahmoud Taha

NMSU – Jim Cowie, Chris Fields,
Hung Nguyen, Bill Ogden, Ram Prasad

MIIS – Gary Ackerman, Markus Binder,
Sundara Vadlamudi

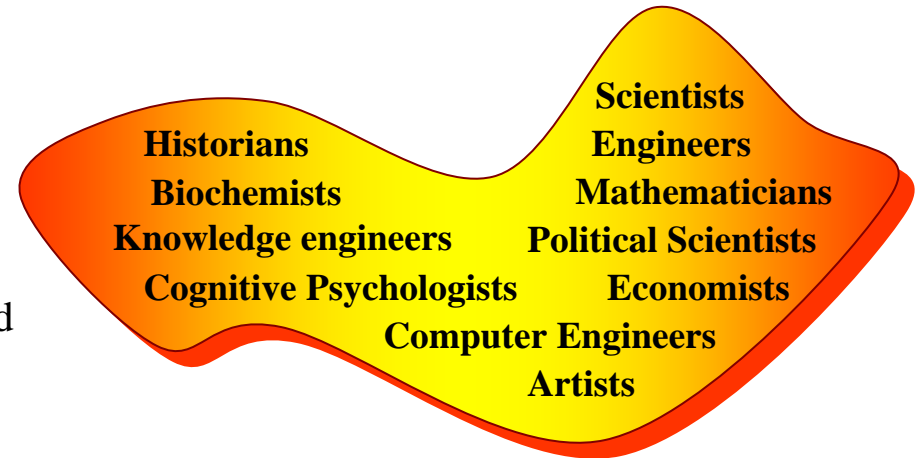

Goal in year one

Develop a R&D Plan to Build a Multivariate Decision-Making System

Specifically:

Outline an Architecture for *CB Defense Investment Decisions* that provides:

- *Capability Assessment*
- *S&T investments Prioritization*
- *S&T Resource allocation decisions*

Perform Technique Assessments that include:

- *Strawman Applications Development*
- *Processes Validation*

Engages a broad-based team of creative professionals



Design Goals

- Develop the analytic and algorithmic framework for a tool that assists decision-makers who create funding portfolios intended to minimize threat-consequences.
- Create a feasible system architecture to evaluate modeling, analysis approaches, and user interactions within this framework.

Ultimately: A usable and flexible DS tool



Design Philosophy

- *Utility to the decision maker*
 - Tied to key user profiles
 - Flexible in use
- *Transparency, not a black box*
 - Shows the evolutionary process of derived outcomes
 - Illustrates cause and effect relationships through visualization
- *Looking for “unexpected outcomes”*
 - Adds information – not just obvious outcomes
 - Minimizes the effect of preconceived notions and biases
 - Provides new ideas and perspectives of the problem space
- *Tuning is evolutionary*
 - Capable of correcting and learning from false outcomes
 - Tool improves with use

Transparency is paramount



Aligning tool with CB Vulnerability Reduction Process (FM 3-11.14)

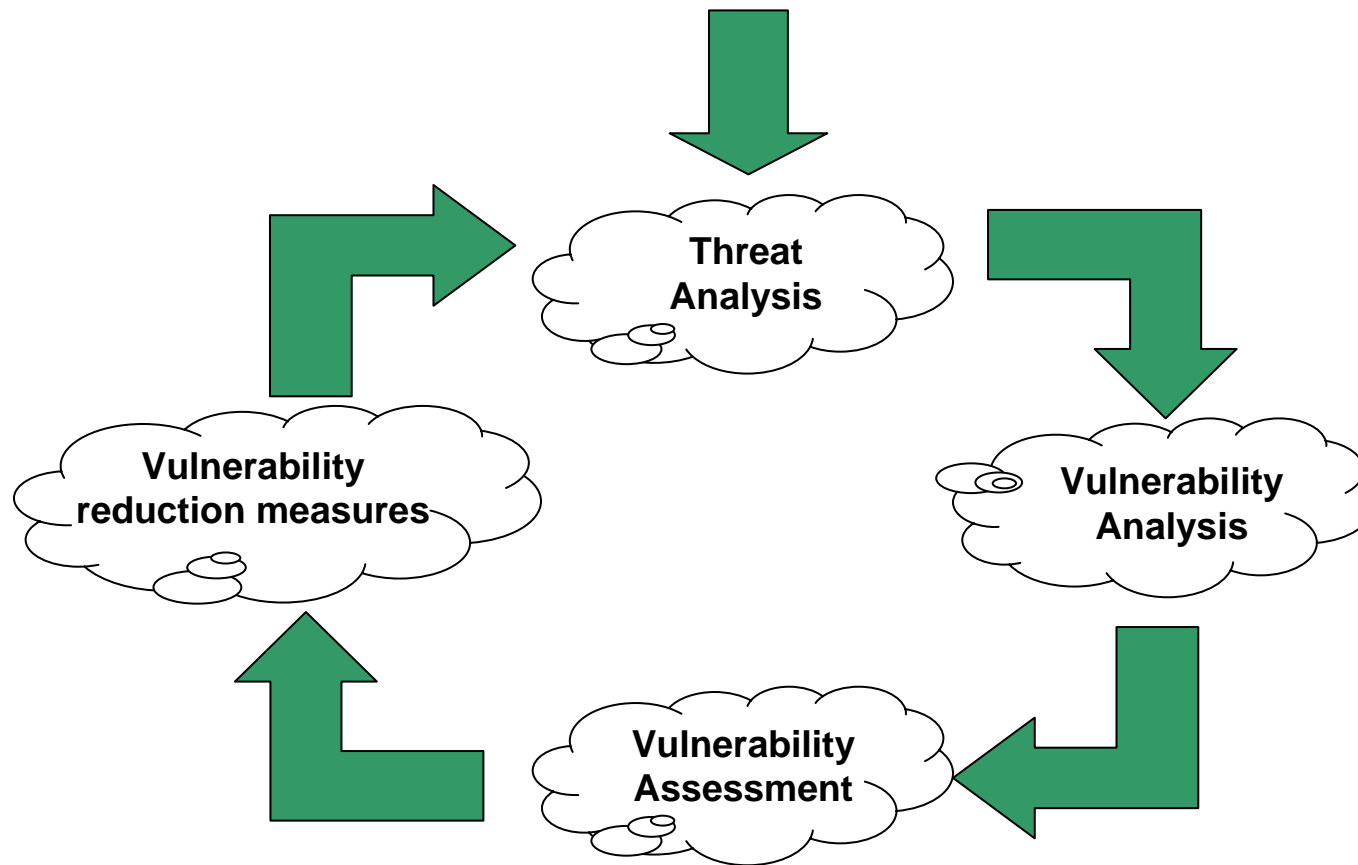

Goal is to provide iterations for analysis



Specification of Incident Scenarios

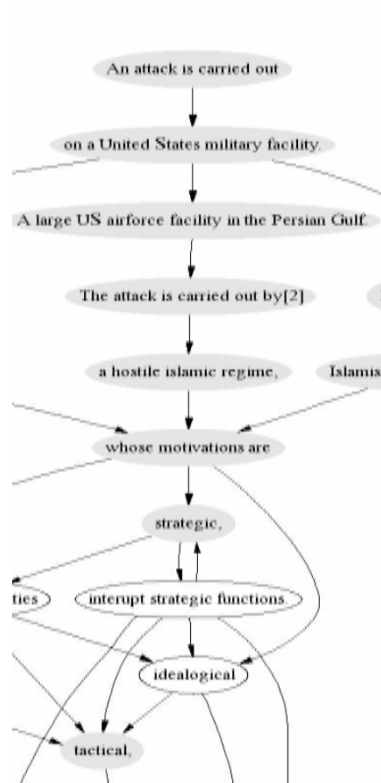

- Discrete Possibility Tree (ala LED @ LANL)
- CBRN Data Model used
- Spanning set of incident scenarios (IS)
- Vector of consequences per scenario
- Possible continuous IS space
- Possible continuous consequence space
- Threat Analysis, Vulnerability Analysis, and Assessment are integral to the Incident Scenario space

Incident Scenarios were developed for use in our model and are key to FY06 effort



Threat and Incident Characterization Incident Scenario Tree

- Incident scenarios:
 - Threat analysis
 - Characteristics - type
 - Attacker objectives
 - Site selection – typical and special sites
 - Vulnerability analysis/risks:
 - Site characteristics
 - Site readiness
 - Vulnerability assessment/consequences:
 - Extent of mission disruption
 - Casualties
 - Length of disruption
 - Collateral damage
 - Geo-political impact
 - Vulnerability Reduction - mitigation costs and effectiveness
- Incident data for analysis:
 - Expert input and simulation
 - Existing data from sites
 - Site survey and analysis

An Incident Tree based on the LANL LED program schema will determine a large set of incident scenarios from which risks (based on impact selection) will be assigned by experts.

Effects/consequences from each selection combination is an incident with a set of incident data including risk data.

Related talks:

- ***Dr. Steve Helmreich, et al., 2:30, Wed***
- ***Dr. Ram Prasad, et al., 3:30, Wed***
- ***Gary Chevez, et al., 8:35, Th***



Vulnerability Reduction S&T Mitigation and Cost

- Options
 - Current site plan status
 - COTS options - combinations
 - S&T options - combinations
- Cost of Options
 - deployment and
 - operation,
 - effectiveness,
 - time to deployment,
 - etc

User adjustable funding portfolio for the set of S&T vulnerability reductions

S&T costs and mitigation effects from each incident yields a set of S&T/incident data impacting and altering the risks from that incident



Initial Architecture

No Temporal Dynamics – First Generation

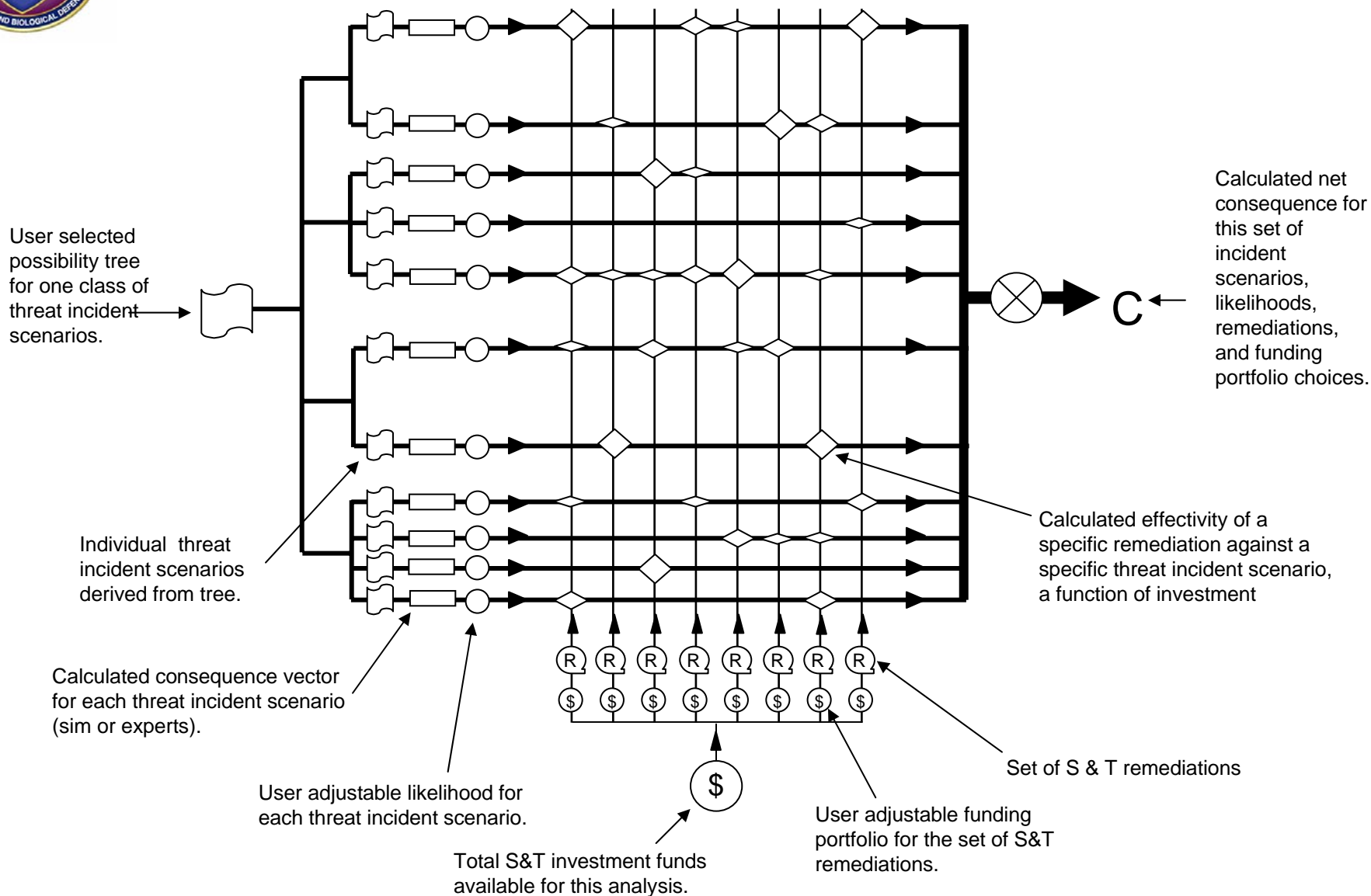



Creating Models of Costs and Effectiveness

- Relates remediation funding level to effectiveness against a given IS-scenario's consequences.
- Simulation
- Expert examples
- Interpolation using machine learning
- Knowledge based systems

Analysis, recently initiated, will be a major effort for FY06



Optimization Loop

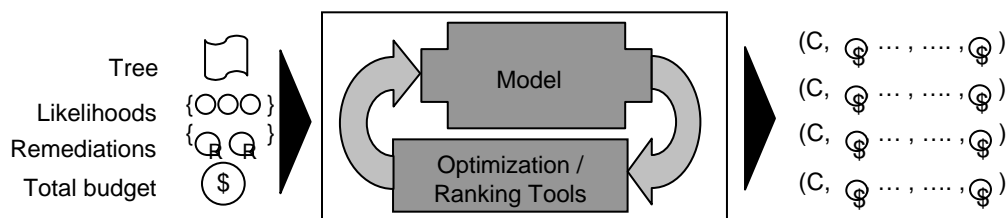
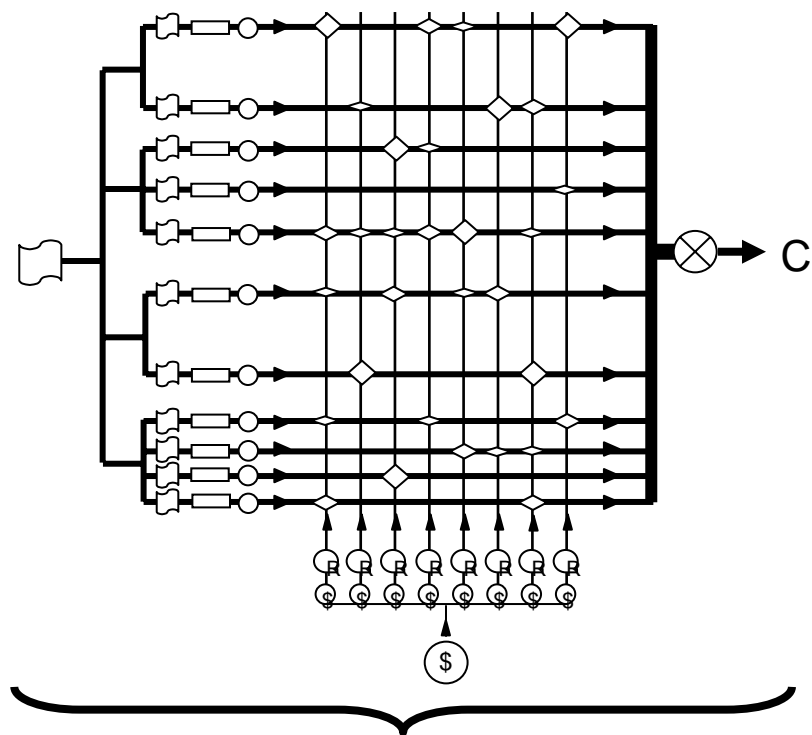

Input Parameters

Analysis Framework

Ranked Consequences



Optimization

Allocation of funds to minimize expected consequences

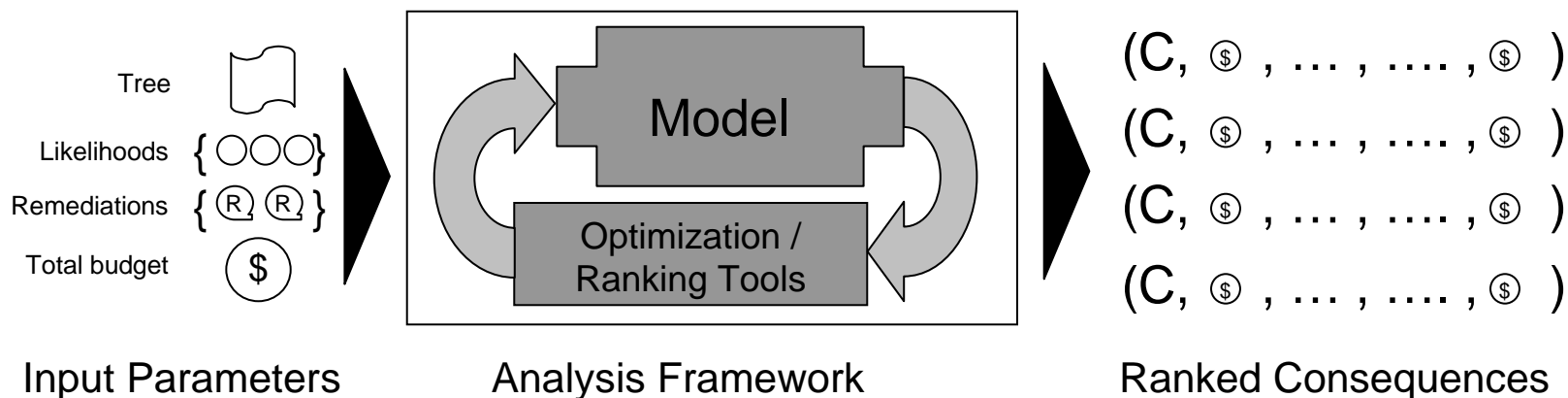

*We analyzed existing optimization and ranking tools
for their relevance to the problem space*

Related talks:

- Dr. Hung Nguyen, etal., 4:30, Wed***
- Dr. Roshan Rammohan, etal., 9:30, Th***



Temporal Dynamics

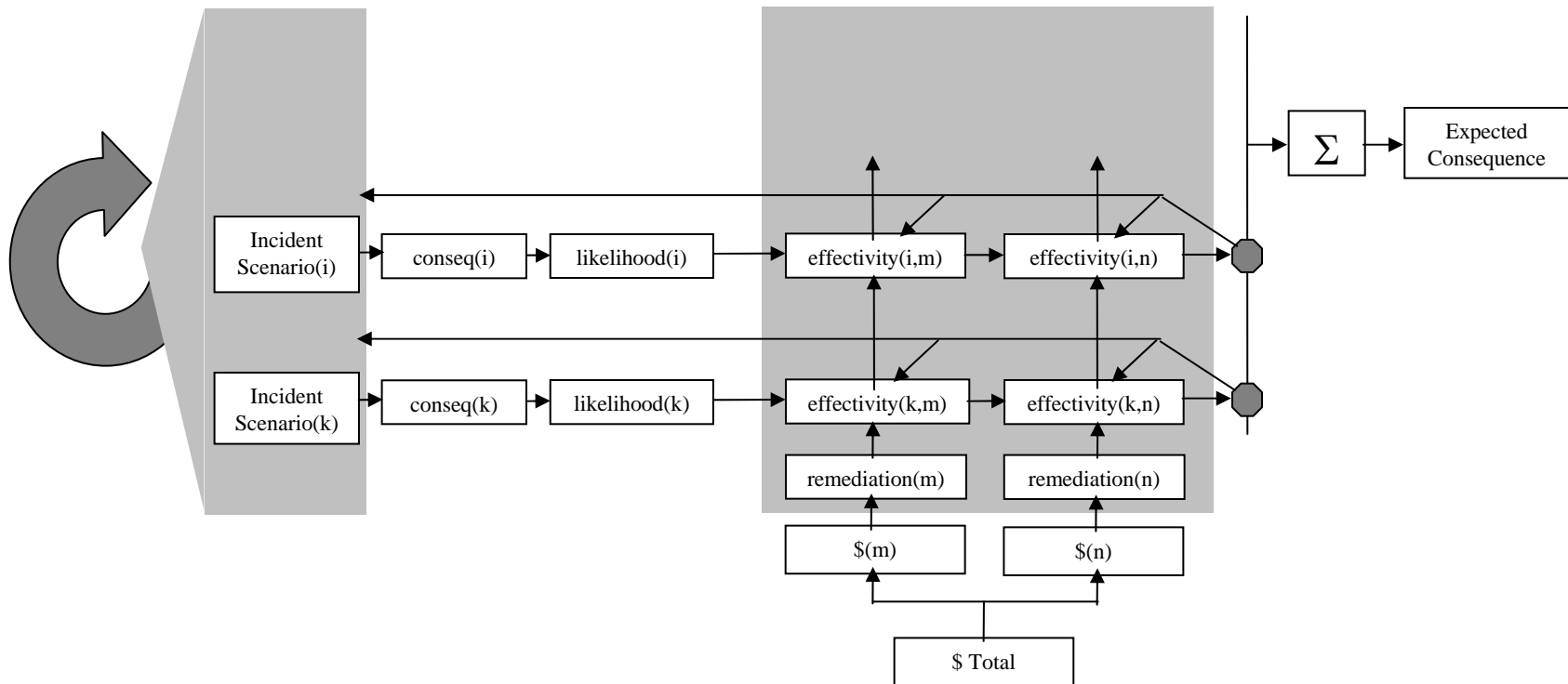

Temporal Dynamics is part of 2nd generation framework with implication for model in FY06



Visualization of Mockup System (1st Generation)

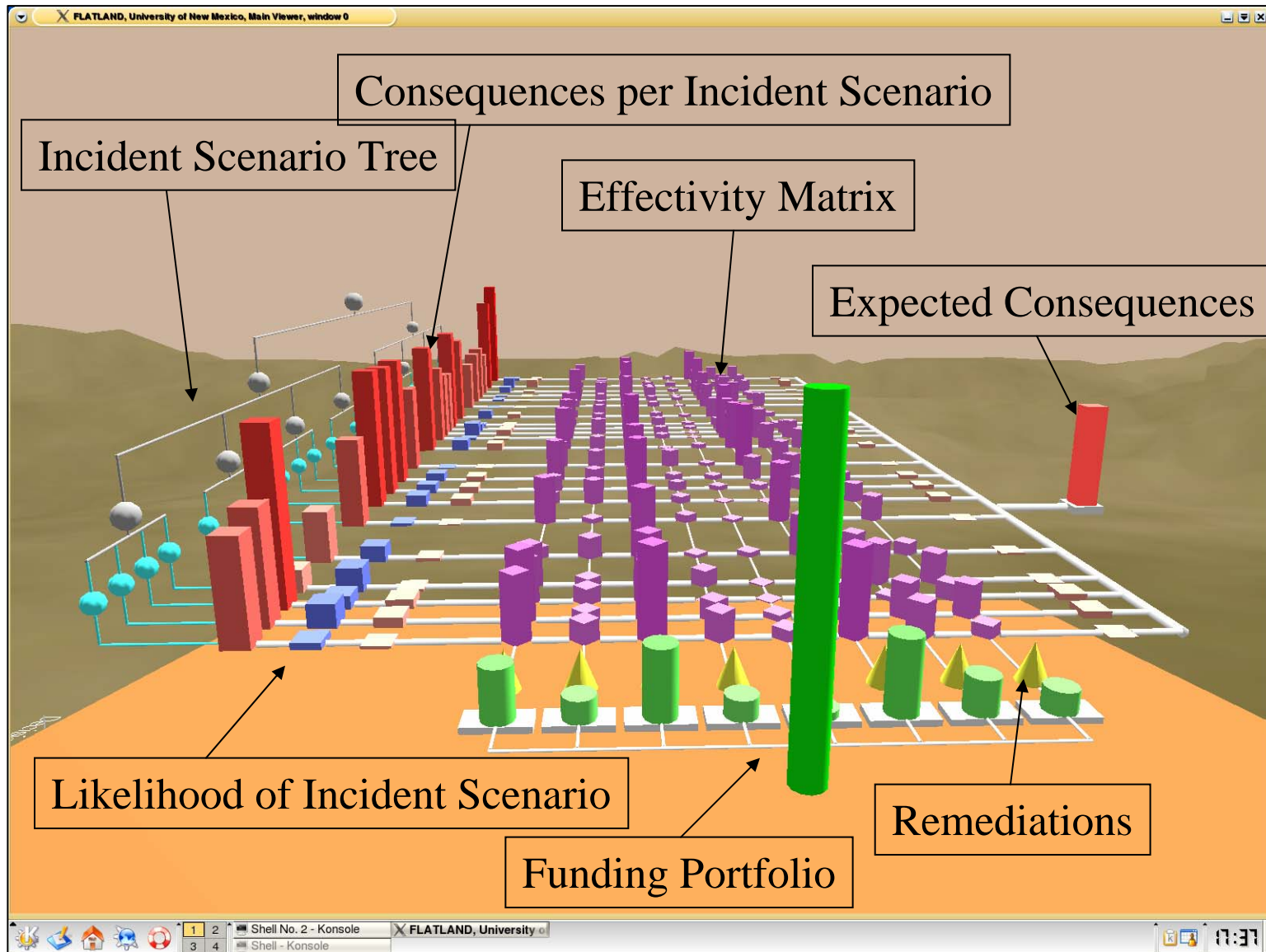



Visualization Features

- Complete visibility into computational model
- Multi-sensorial approach increases comprehension
- Consequence-flow metaphor
- Real-time user adjustable parameters
- Multi-resolution to manage complexity
- Drill-down for more details
- Animation of calculations and optimization

Visualization interface provides flexibility and transparency

Related talks:

- *Dr. Tom Caudell, et al., 2:00, Wed*
- *Dr. Panaiotis, et al., 9 AM, Th*
- *Bill Ogden, et al., 4:00 Wed*



Visualization of Mockup System

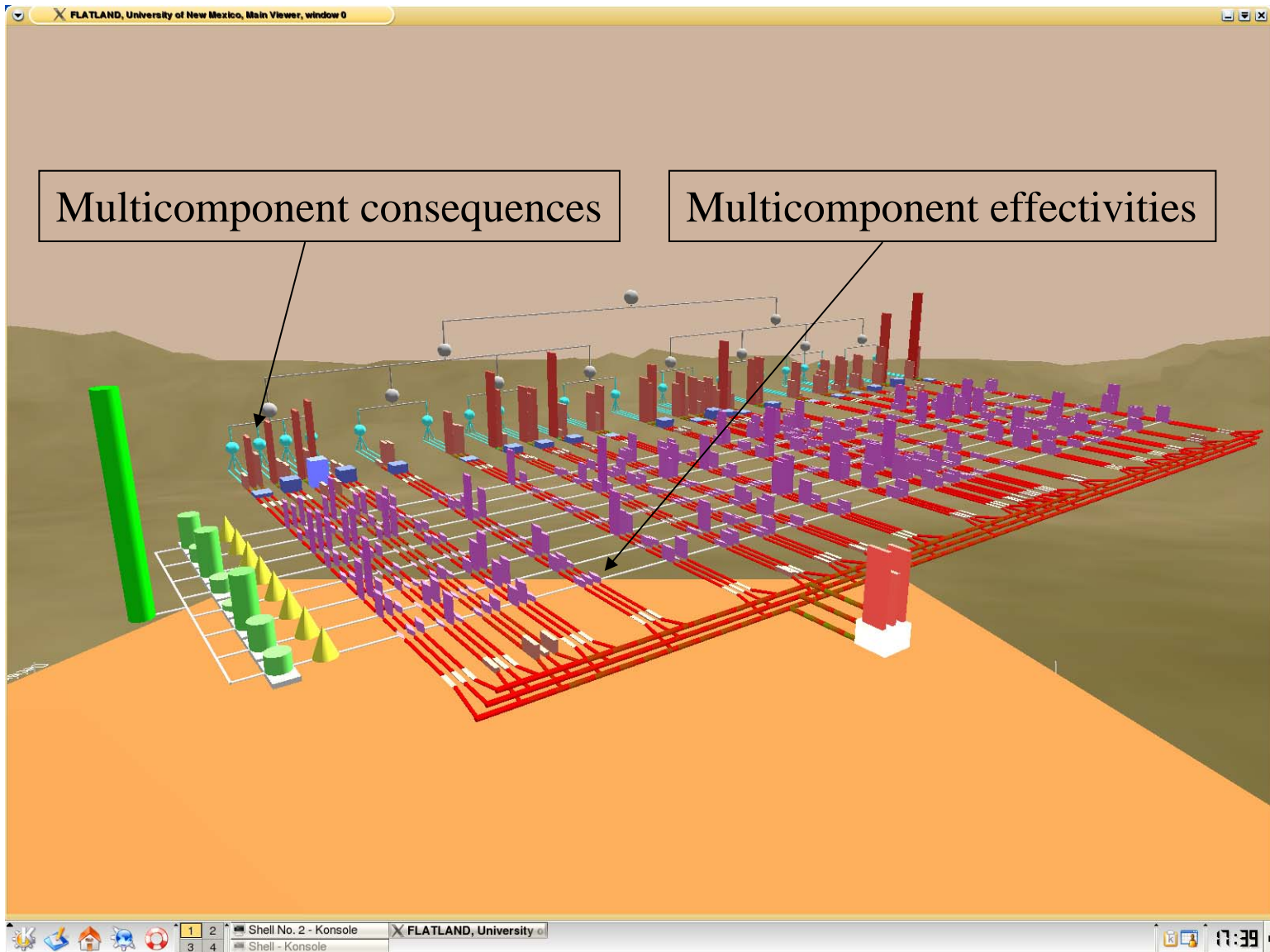



FY06 Effort

- **Refine Framework – 2nd Generation**
 - Incident Scenario (IS) framework and representation trees – define and tie to CBRN data model
 - Remediation and cost representations – define and analyze
 - Effectivity representations – define and analyze
 - User profiling – provides for multiple user-types
 - Temporal issues – define and embed
 - New complex analysis tools developed as framework evolves
- **Mock-up Tool**
 - Provide a limited working model
 - Match analysis tools to specific use
 - Test and obtain user assessment
 - Consider potential of wider use