



The Military Missions and Means Framework (MMF)

Dr. Paul H. Deitz, Technical Director
Army Materiel Systems Analysis Activity
phd@amsaa.army.mil; 410-278-6598

Mr. Jack H. Sheehan, PM Knowledge Intgr
DoD DOT&E/C3I & Strategic Systems
Jack.Sheehan@osd.mil; 703-998-0660 x448

COL(R) Bruce A. Harris, Dir Trng & Perf
Dynamics Research Corporation
bharris@drc.com; 978-475-9090 x1878

Mr. Alexander B. H. Wong, Ofc of Tech Dir
Army Materiel Systems Analysis Activity
awong@amsaa.army.mil; 410-278-6625

LTC(R) Britt E. Bray, Senior Analyst
Dynamics Research Corporation
bbray@drc.com; 913-758-0514

February 2004

Presented to MG Robert W. Mixon Jr., Deputy Director, TRADOC Futures Center, Ft. Monroe, VA, February 26, 2004.

Purpose

Demonstrate the applicability of the Missions and Means Framework for warfare representation.

Agenda

- **Purpose**
- **MMF applied to operational scenario**

MMF Application - Situation

Road to War

- Radical elements form new government, seek to force recognition by UN as legitimate government.
- Legitimate, pro-Western Government of Orangeland is overthrown by radical elements and forced into exile.
- Majority of Orangeland's conventional military forces are loyal to new government. Orangeland invades neighboring country of Blueland.
- United States and its coalition partners believe national interests and regional stability are threatened. They take military action to drive Orangeland forces from Blueland; remove rebel government from power; restore legitimate, pro-Western government; stabilize region; and protect U.S. and coalition vital interests.

Current Situation

- Coalition forces have commenced offensive ground operations in the region to drive Orangeland forces out of Blueland and continue attacking to isolate rebel government leadership inside capital of Orangeland.

Mission

- CJTF intends to isolate rebel government leadership in the capital by defeating majority of conventional forces well outside the capital and preventing them from reinforcing security forces protecting the rebel leadership inside the capital.

MMF Layered View: SN

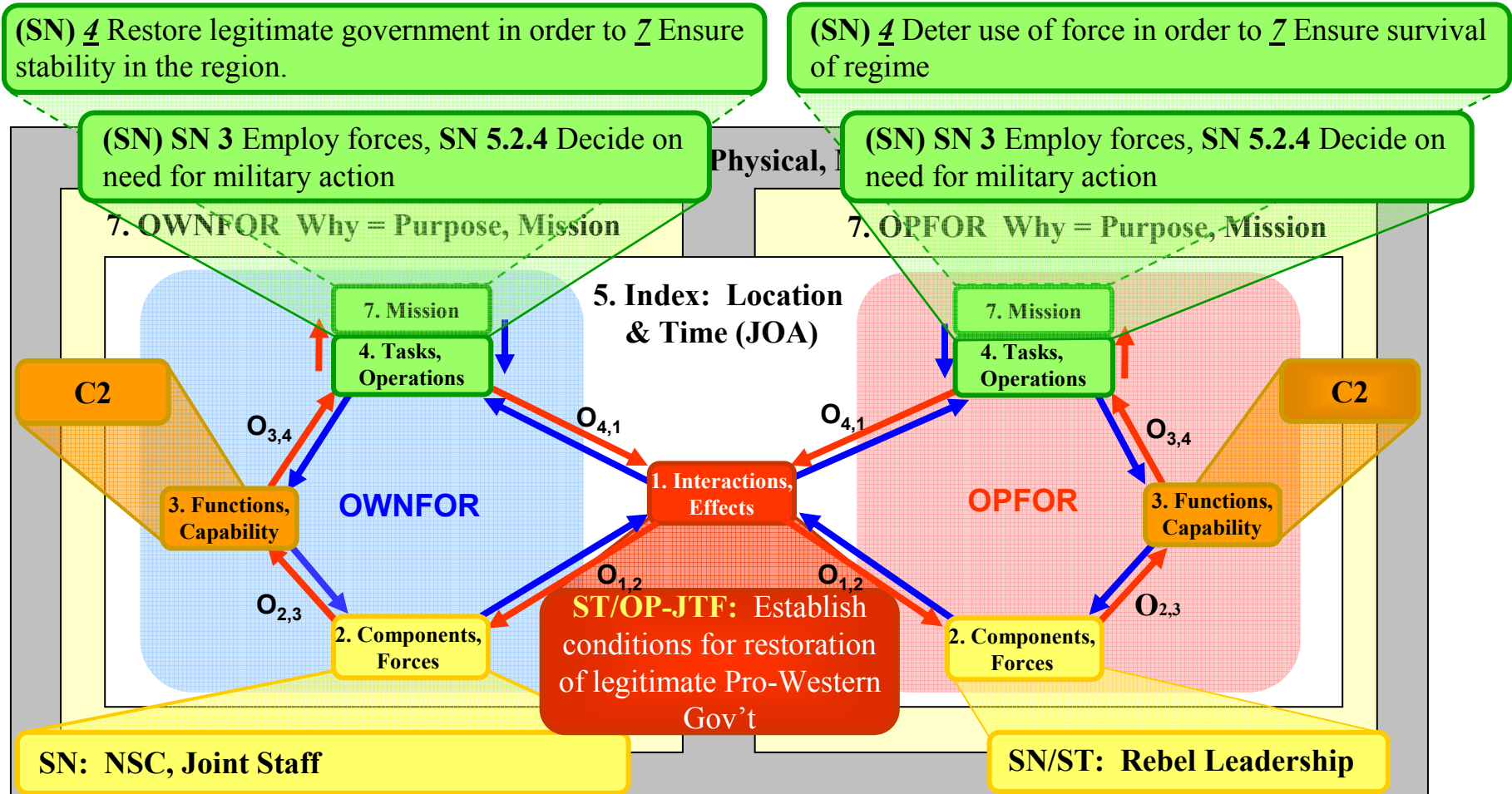

JOINT TASK FORCE (JTF)

JTF MISSION:

Conduct military operations in the JOA in order to set the conditions for restoring legitimate government by defeating Rebel forces, secure energy centers, and isolating Rebel government in the capital region of Orangeland.

KEY TASKS:

- | | |
|--|-----------------------------------|
| (1) Achieve air superiority | (4) Destroy WMD Capability |
| (2) Facilitate control of energy centers | (5) Defeat resisting Rebel forces |
| (3) Isolate rebel government | |

END STATE: Rebel forces are defeated and legitimate government is restored

JTF ORGANIZATION

Ground (CJFLCC/JFMCC)

1x UE (3x UA's, 3x SBCT, 1x PIR BN)
1x Mechanized Division
1x SBCT
1x MEB
1x AASLT BDE

Air (JFACC/JFMCC)

1 x MAW
2 x AEG
2 x CAW
B-1B, B-2, B-52 Missions

SOE/PSYOP/CAB (JPOTF/JSOTF)

1 x SFG (-)
1 x Ranger BN
2 x SEAL Teams
PSYOP/CAB

Sea (JFMCC)

2 x CBG

MMF Layered View: ST

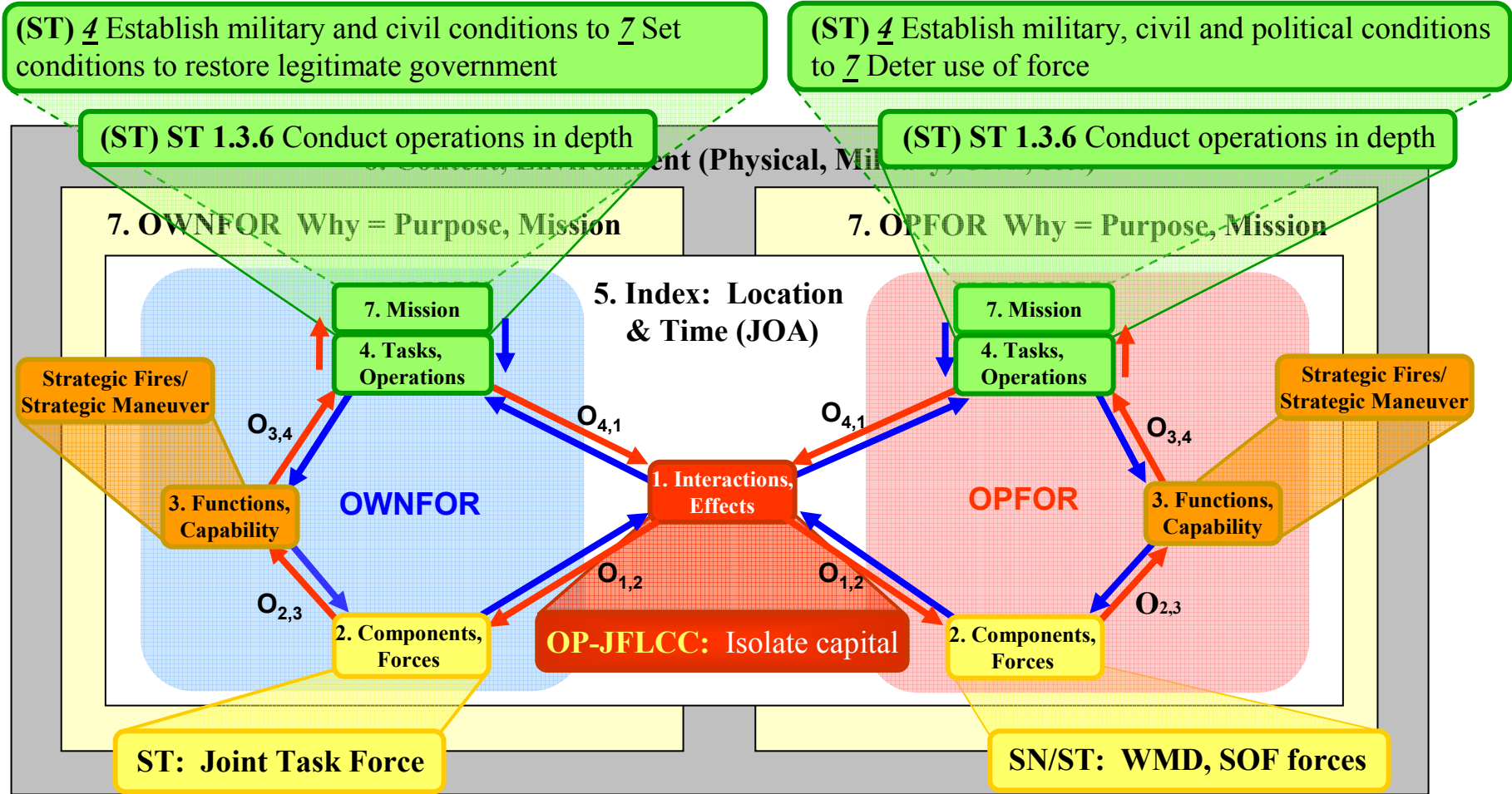

JOINT FORCES LAND COMPONENT COMMAND (JFLCC)

JFLCC MISSION:

Conduct offensive operations in order to defeat Rebel forces in Orangeland, secure key energy production facilities and secure rebel government inside the capital of Orangeland.

KEY TASKS:

- (1) Defeat the Rebel forces in zone
- (2) Destroy WMD capability
- (3) Secure key oil and gas pipelines and production facilities
- (4) Surround capital region of Orangeland
- (5) Secure rebel government leadership inside capital of Orangeland

END STATE: Rebel forces have been defeated, the flow of oil and gas is uninterrupted, capital region is secure with rebel government inside, WMD threat is eliminated

JFLCC ORGANIZATION

Ground (CJFLCC/JFMCC)

1x Mech Division

1x UE (3x UA's, 3x SBCT, 1x PIR BN)

1x SBCT

1x MEB

1x AASLT BDE

MMF Layered View: OP

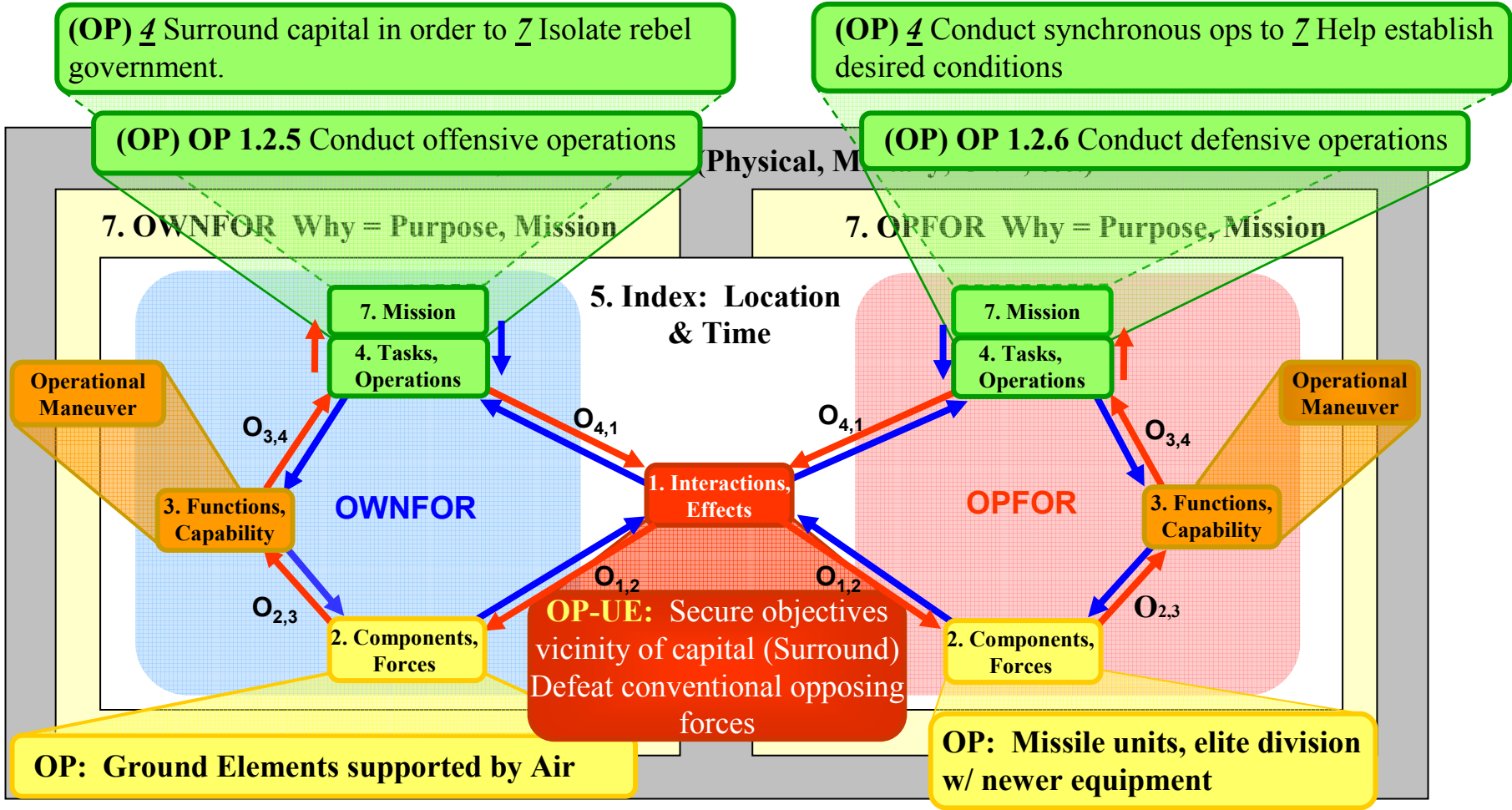

→ **Synthesis**
→ **Employment**

UNIT OF EMPLOYMENT

UE MISSION:

Attack to defeat Rebel forces in zone, surround the capital of Orangeland and isolate the rebel government inside the capital

INTENT:

PURPOSE: Set conditions for restoration of legitimate government in Orangeland

KEY TASKS:

- (1) Conduct vertical maneuver in order to isolate enemy forces
- (2) Conduct deliberate attack to Defeat Rebel forces in zone and prevent return to capital
- (3) Secure key facilities with minimal collateral damage

END STATE: Rebel forces are defeated, UE has surrounded the capital, rebel government leadership and facilities are secured.

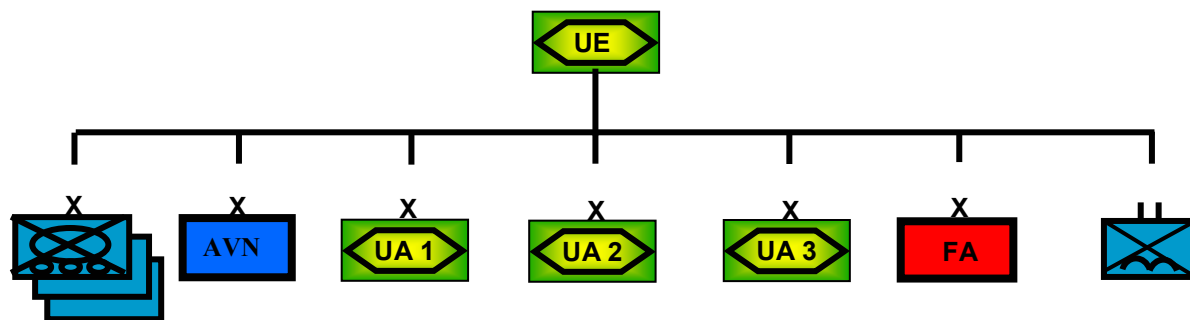

MMF Layered View: TA-Joint

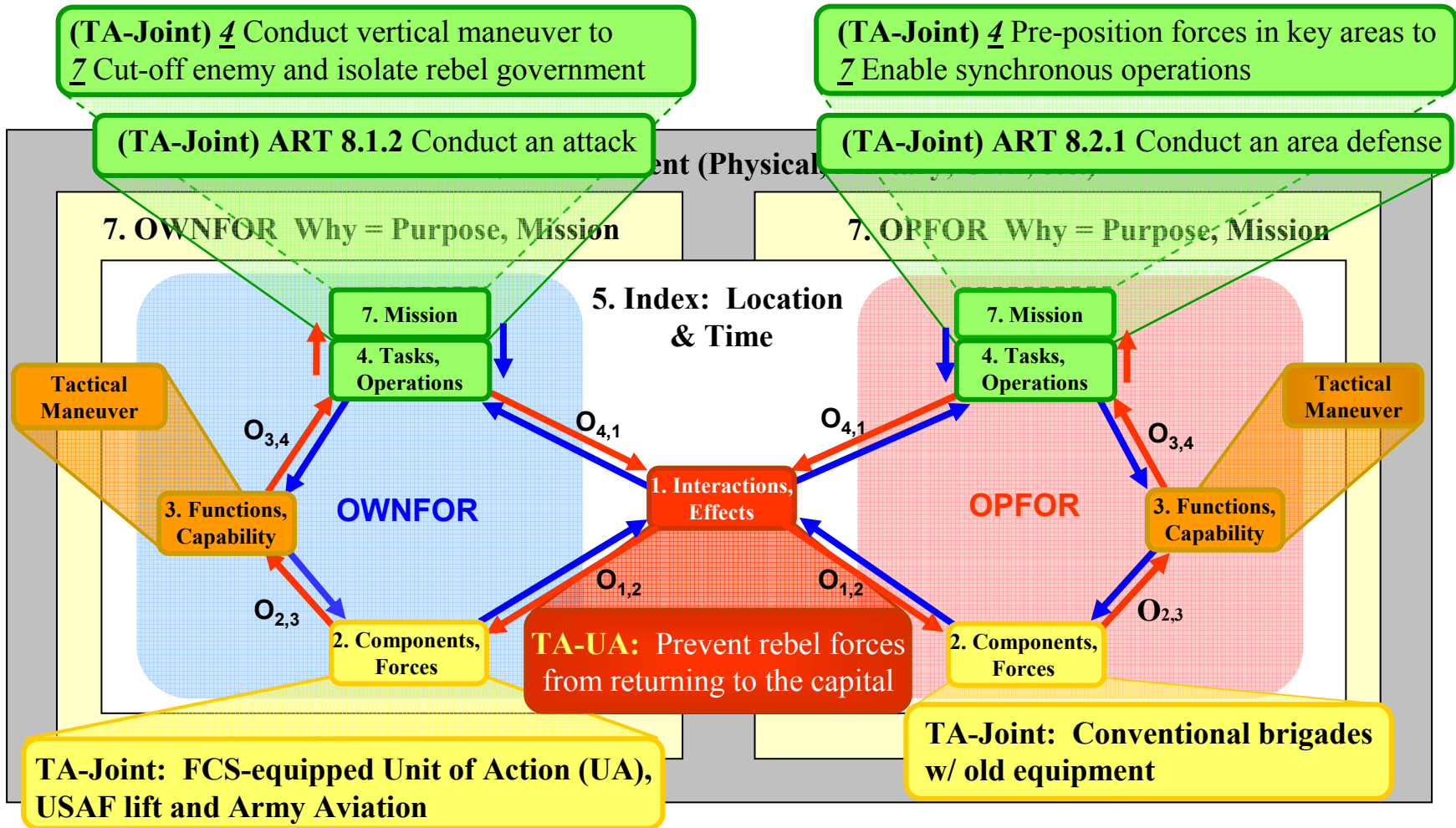

 **Synthesis**

 **Employment**

UNIT OF ACTION 1

(Increment 1, Threshold Design)

MISSION:

UA1 attacks in order to cause Rebel forces to fight in multiple directions and facilitate the attack to secure OBJ CAMEL

INTENT:

Purpose: Prevent Rebel forces from repositioning to Orangeland capital

Key Tasks:

CAB1 Secure OBJ BLOCK in order to protect left flank of CAB2

CAB2 Secure OBJ CAMEL in order to enable UA2 seizure of OBJ BAT

CAB3 Secure OBJ KNIGHT in order to protect left flank of CAB2

End State: Rebel forces defeated and cut-off, CABs in position to conduct follow on ops.

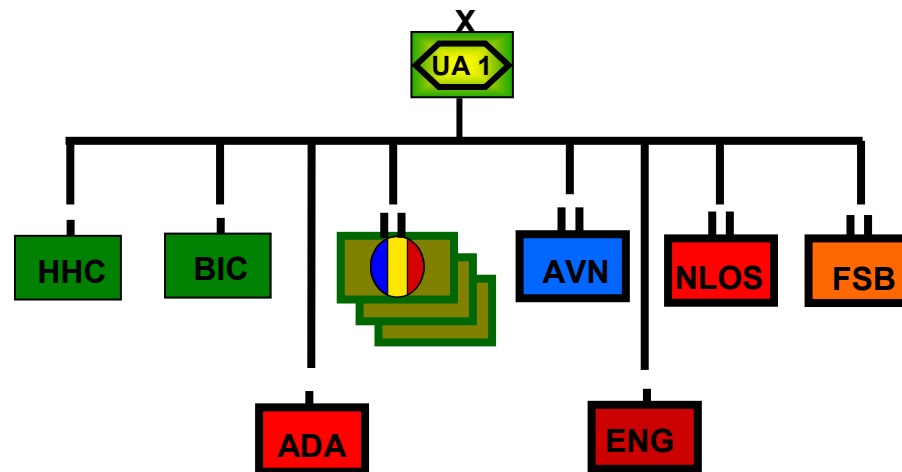

MMF Layered View: TA-Service

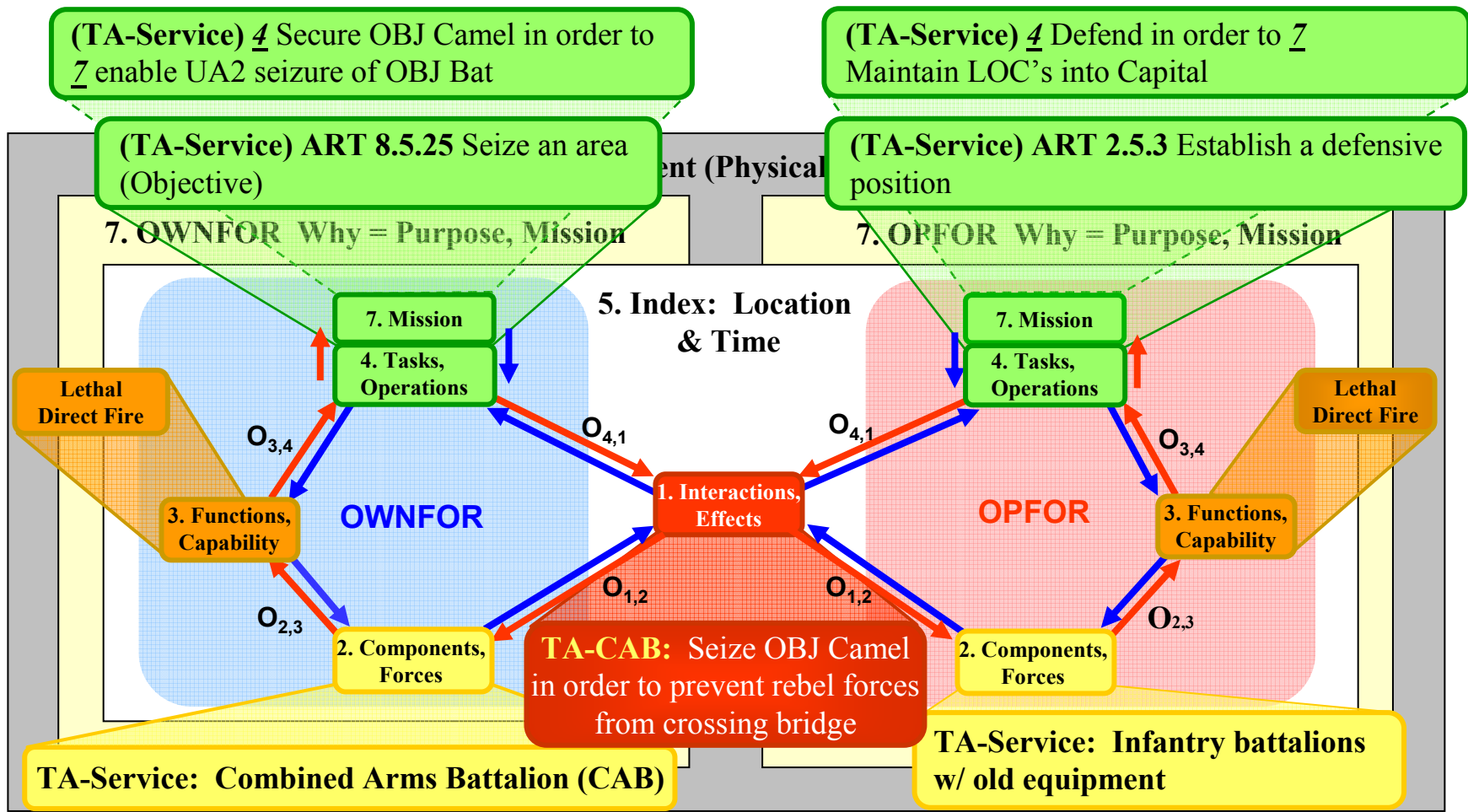

COMBINED ARMS BATTALION 2

MISSION: Attack to secure OBJ CAMEL. On order support UA2 attack on OBJ BAT.

INTENT:

Purpose: Enable UA2 attack to seize OBJ BAT

Key Tasks:

- (1) Conduct Vertical maneuver to cause Rebel forces to fight in multiple directions
- (2) Isolate & defeat Rebel forces vic OBJ CAMEL.
- (3) Secure OBJ CAMEL in order to facilitate UA2 attack on OBJ BAT

End State: OBJ CAMEL secure, CAB2 prepared to conduct follow-on urban operations

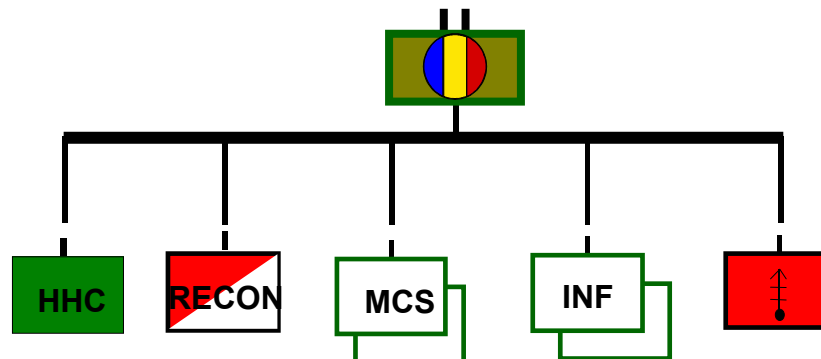

TASKS

- 1. Defeat enemy forces withdrawing to Capital
- 2. Seize bridge vic OBJ BISHOP
- 3. Conduct air assault with 1 dismounted INF CO

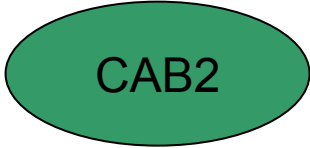

ART 8.5.1 Attack by Fire an Enemy Force or Position

TA 1
Deploy Conduct Maneuver



- ART 2.2 Conduct Tactical Maneuver
- ART 2.4.2 Conduct Nonlethal direct fire against surface target

TA 2
Develop Intel



- ART 1.3 Conduct ISR
- ART 1.3.3.1 Conduct Zone Recon
- ART 1.3.4 Conduct Surveillance

TA 3
Employ Firepower



- ART 3.2 Detect and Locate Surface Targets
- ART 3.3.1.1 Conduct surface to surface attack

TA 5
Exercise C2



- ART 7.2 Manage Tactical Information
- ART 7.2.2 Process Relevant Information to Create a COP
- ART 7.2.3 Display a COP Tailored to User Needs

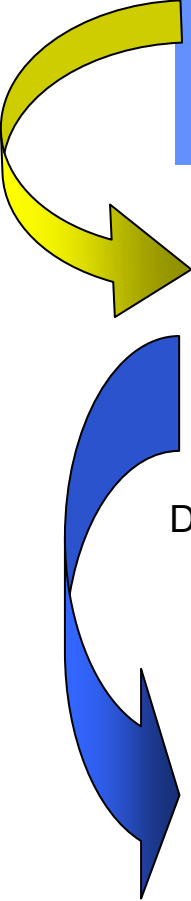

Sample Task Set Applied OT Model

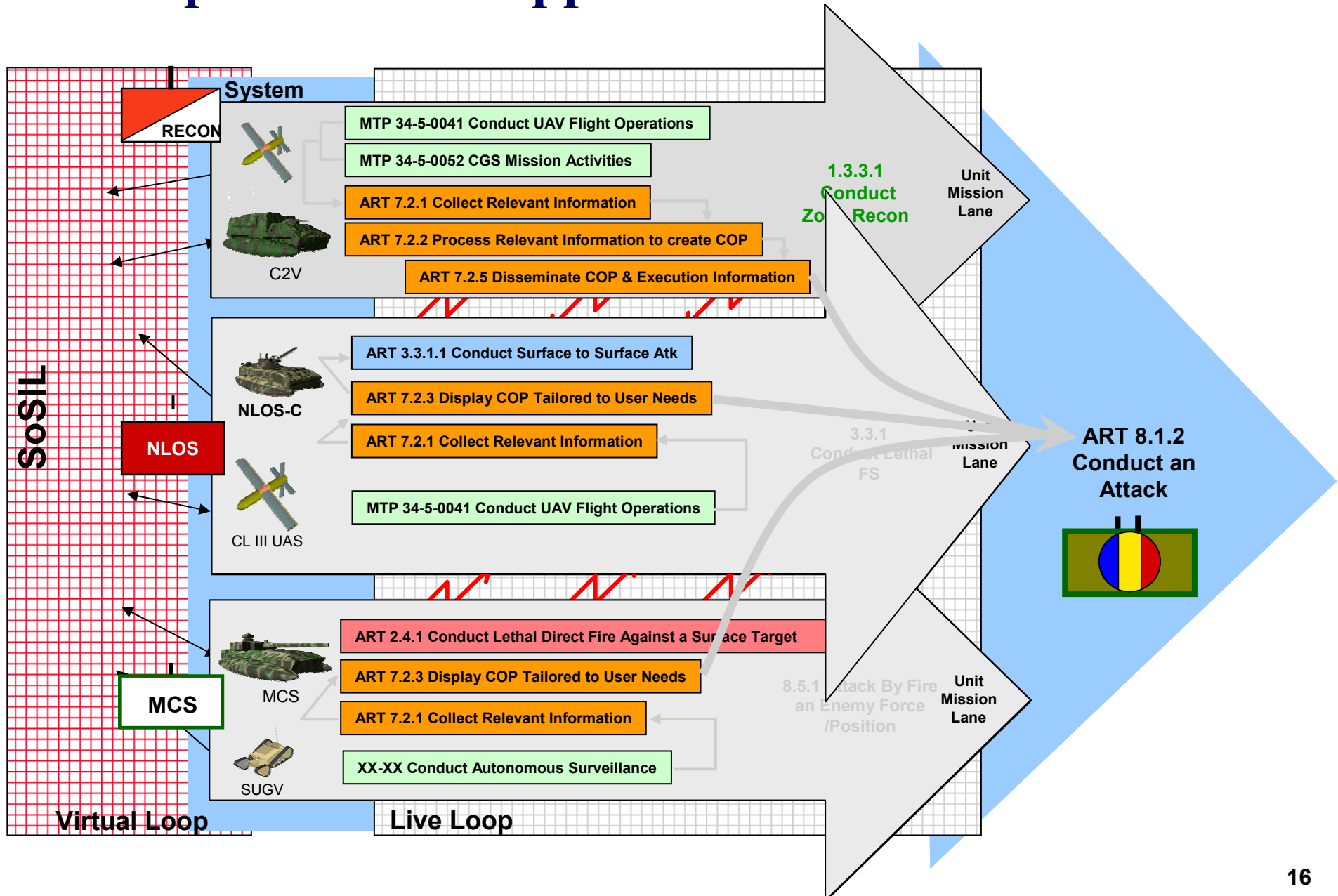

Relating Effects to Utility

**JTF
Commander
Strategic/Operational**

**Establish conditions for restoration of
legitimate Pro-Western Government**

**JFLCC
Operational**

Isolate capital

**UE
Operational/Tactical**

**Secure Objectives vicinity of capital (Surround)
Defeat conventional opposing forces**

**UA
Tactical**

**Prevent rebel forces from returning to the
capital**

**CAB
Tactical**

**Seize OBJ Camel in order to prevent rebel forces from
crossing bridge**

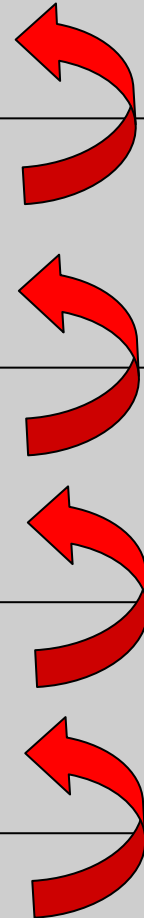

Relating Effects to Utility

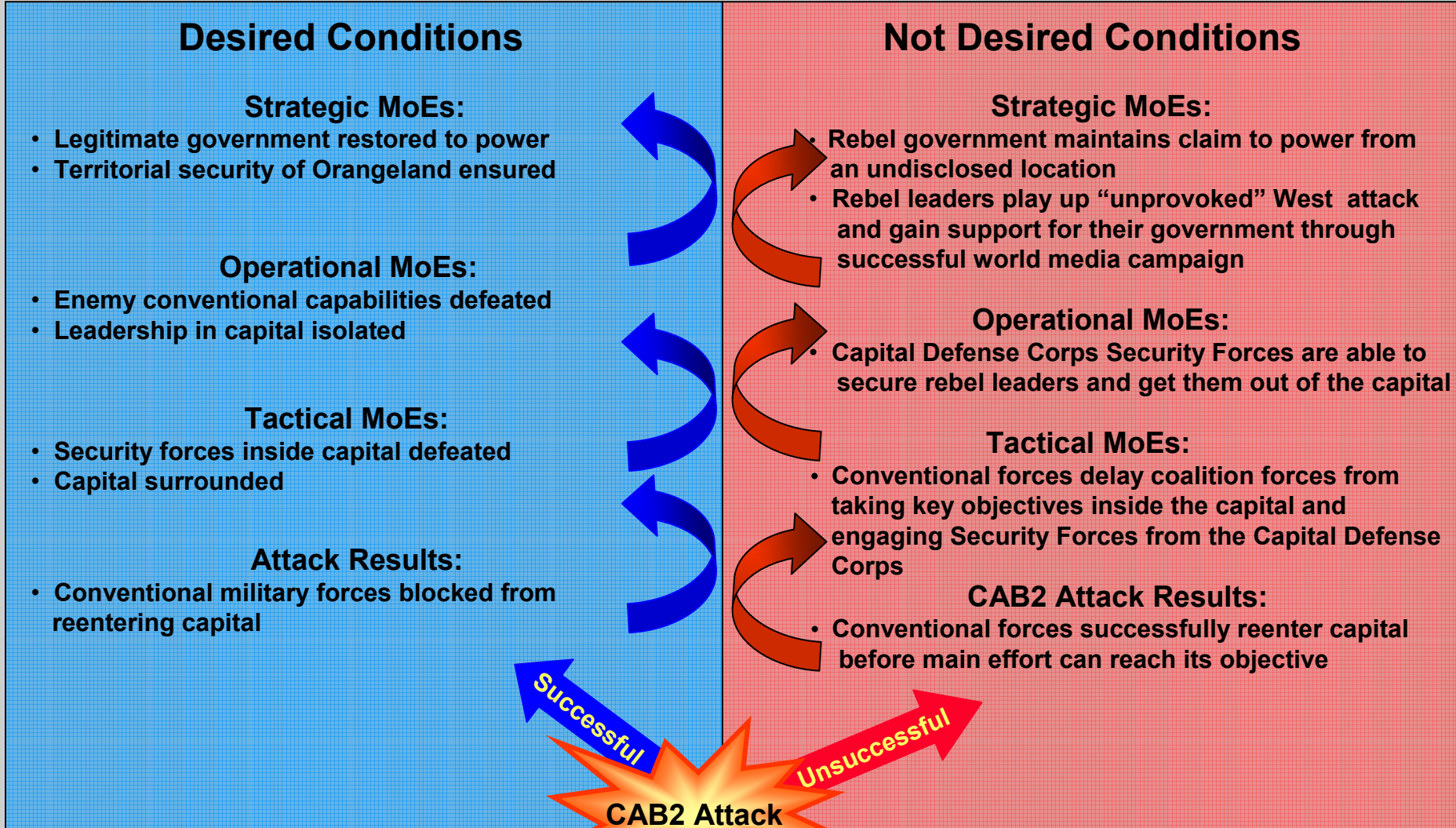

Starting Conditions



The Military Missions and Means Framework (MMF)

Dr. Paul H. Deitz, Technical Director
Army Materiel Systems Analysis Activity
phd@amsaa.army.mil; 410-278-6598

Mr. Jack H. Sheehan, PM Knowledge Intgr
DoD DOT&E/C3I & Strategic Systems
Jack.Sheehan@osd.mil; 703-998-0660 x448

COL(R) Bruce A. Harris, Dir Trng & Perf
Dynamics Research Corporation
bharris@drc.com; 978-475-9090 x1878

Mr. Alexander B. H. Wong, Ofc of Tech Dir
Army Materiel Systems Analysis Activity
awong@amsaa.army.mil; 410-278-6625

LTC(R) Britt E. Bray, Senior Analyst
Dynamics Research Corporation
bbray@drc.com; 913-758-0514

February 2004

Presented to MG Robert W. Mixon Jr., Deputy Director, TRADOC Futures Center, Ft. Monroe, VA, February 26, 2004.

Back Up Slides

Warfighter **Visualizes** the operation and capabilities required to accomplish mission.



MMF enables warfighter to **Describe** vision using framework to ID key elements and tools to capture elements in data form.

MMF prompts capture of the elements below:

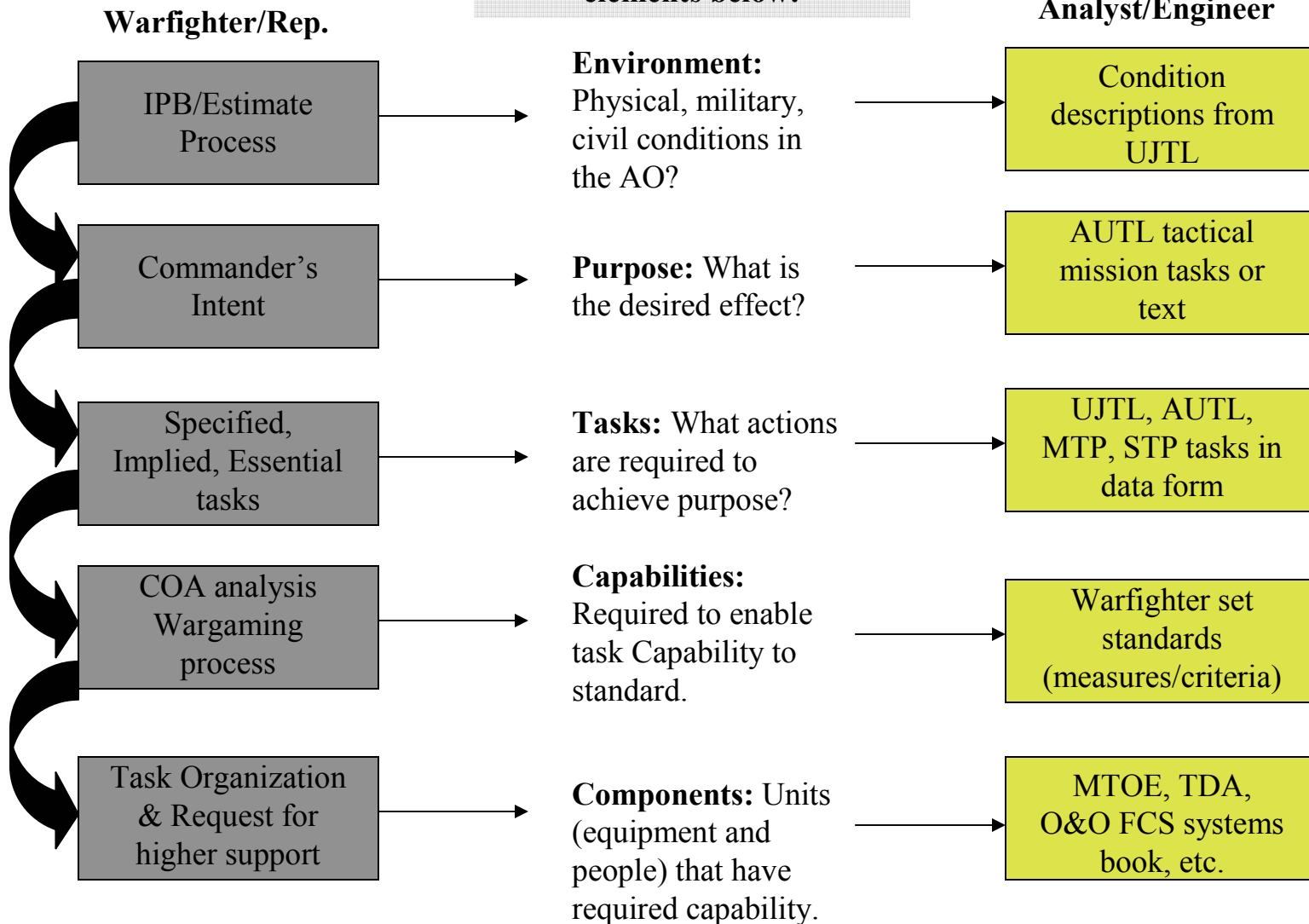

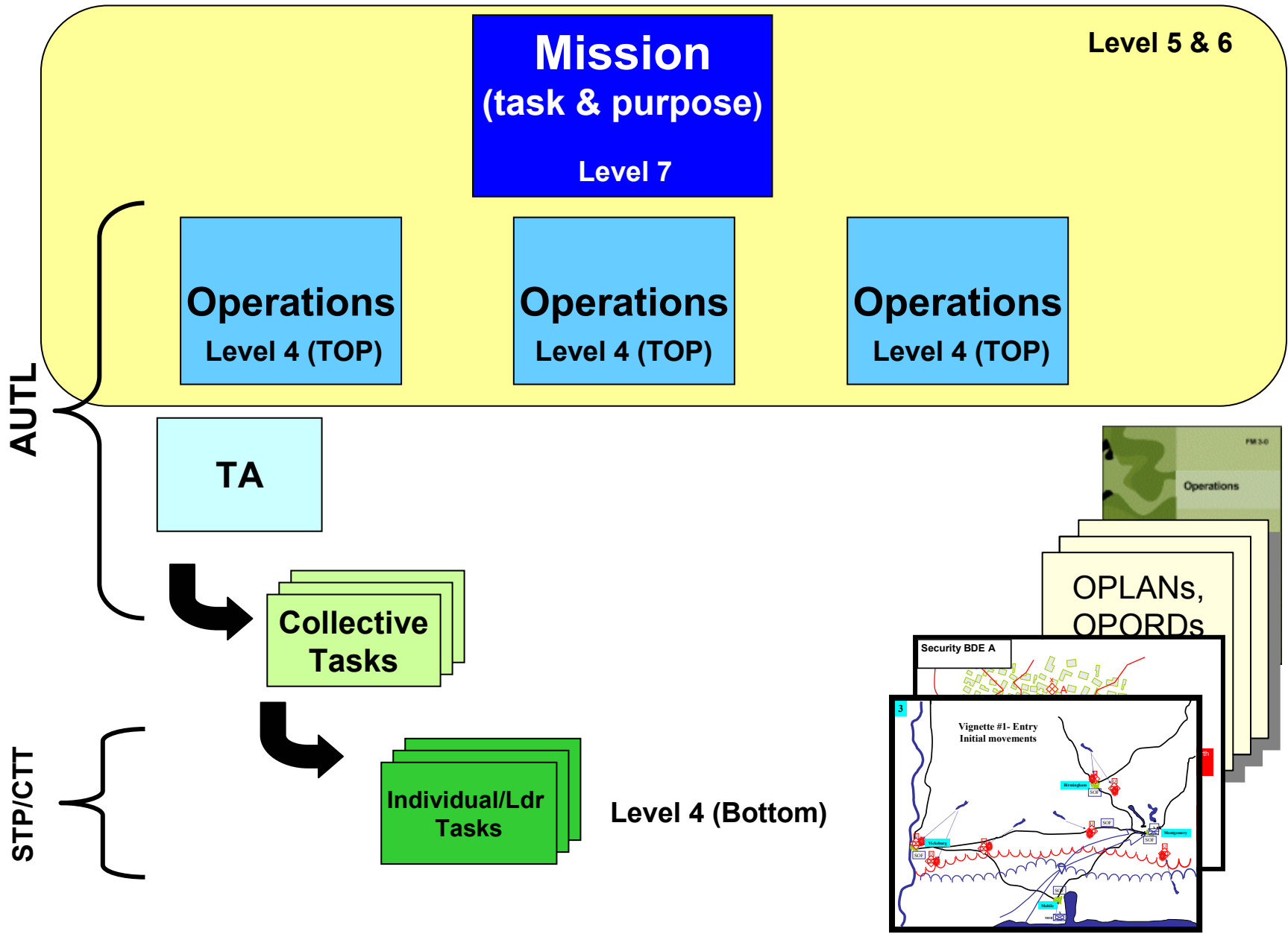

Decomposition Framework

(Supported by Doctrine, TTP, TMs)

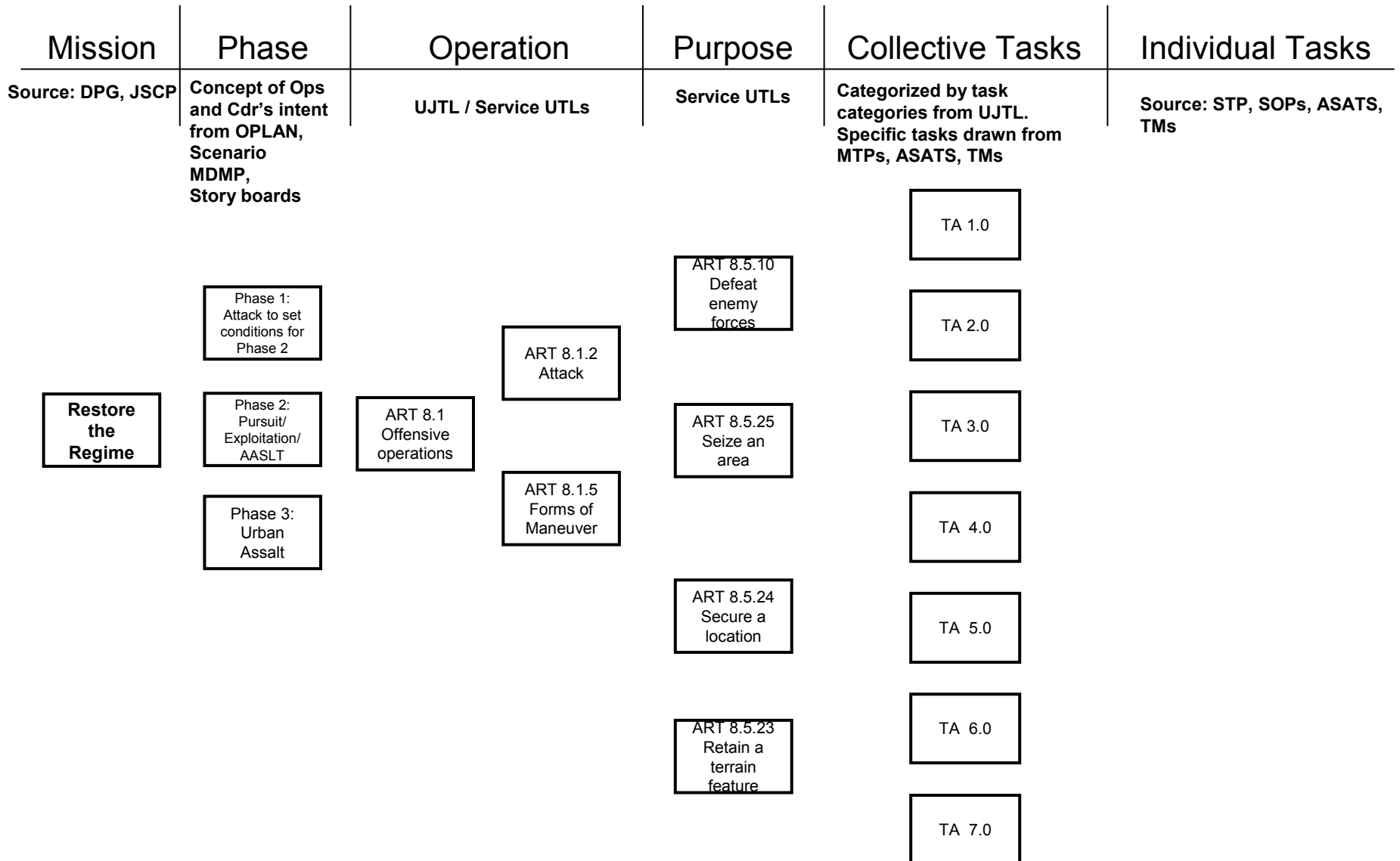

Battle Staff Task Map -- collective to individual

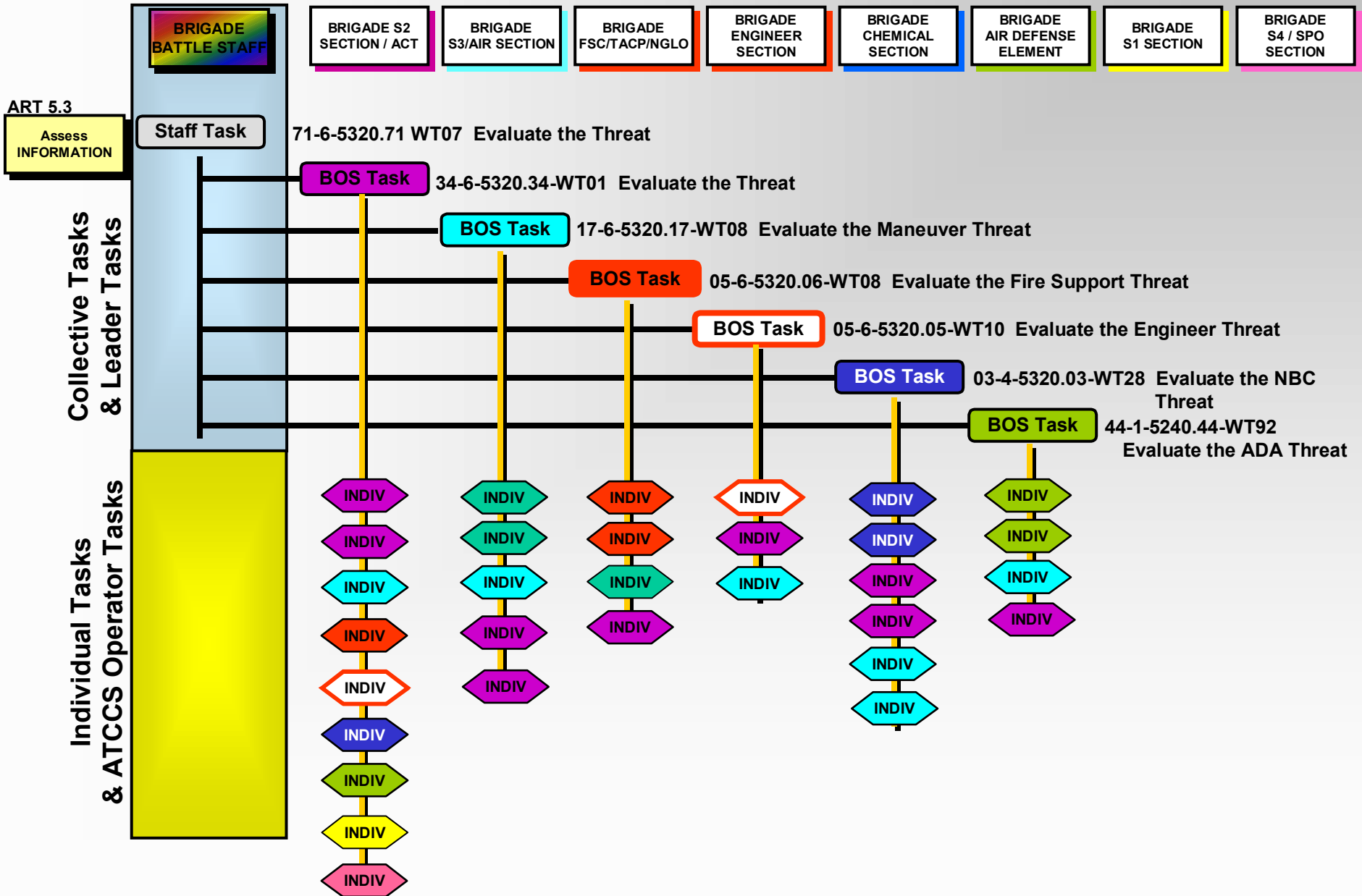

ATEC Mission-to-Capability Trace

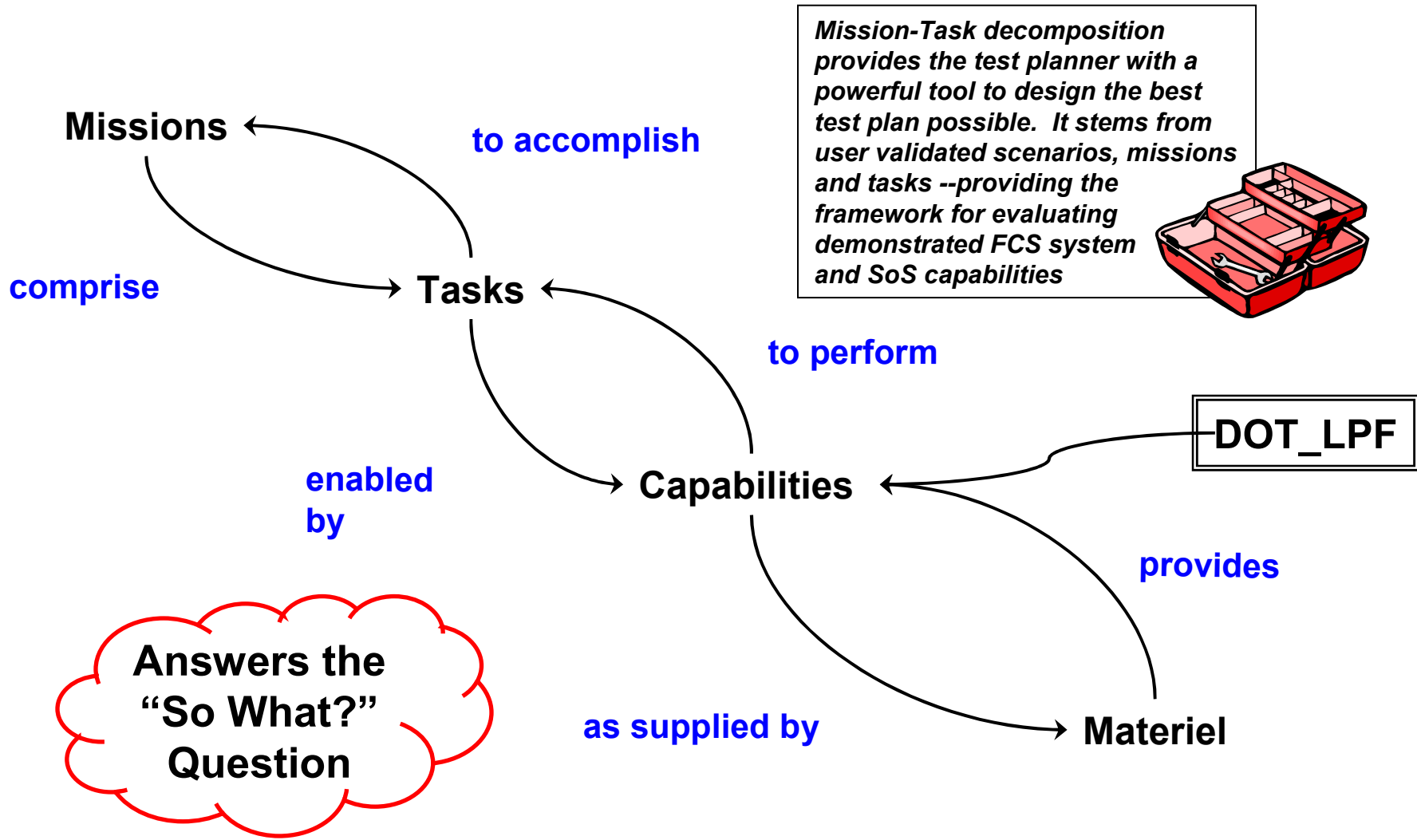

Mission Decomposition

Annex F, O&O
Appendix G, ORD

Source: PM FCS (Purdy)

- Early Entry Operations
- Combined Arms Operations for Urban Warfare to Secure Portion of Major Urban Area
- Rapid Advance to Enemy Center of Gravity
- Mounted Formation Conducts Pursuit and Exploitation
- Dismounted Air Assault Enabled by Mounted Formation In Restricted Terrain
- Dismounted Operations to Conduct Raid on Decisive Point in Jungle/Defensive Operations

Tasks

ART 7.2.3
Display COP
Tailored to User
Needs

ART 7.4.4
Establish
Target Priorities

ART 7.5.2
Conduct Rehearsals

-
-
-

{ Mission # 1
Scenario 1
Scenario 2
•

{ Mission # 2
Scenario 1
Scenario 2
•

-
-
-
-

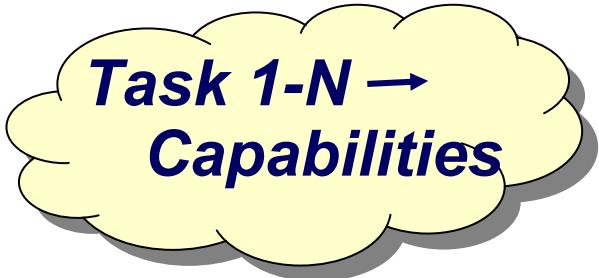

Missions ← to accomplish
 Tasks → comprise

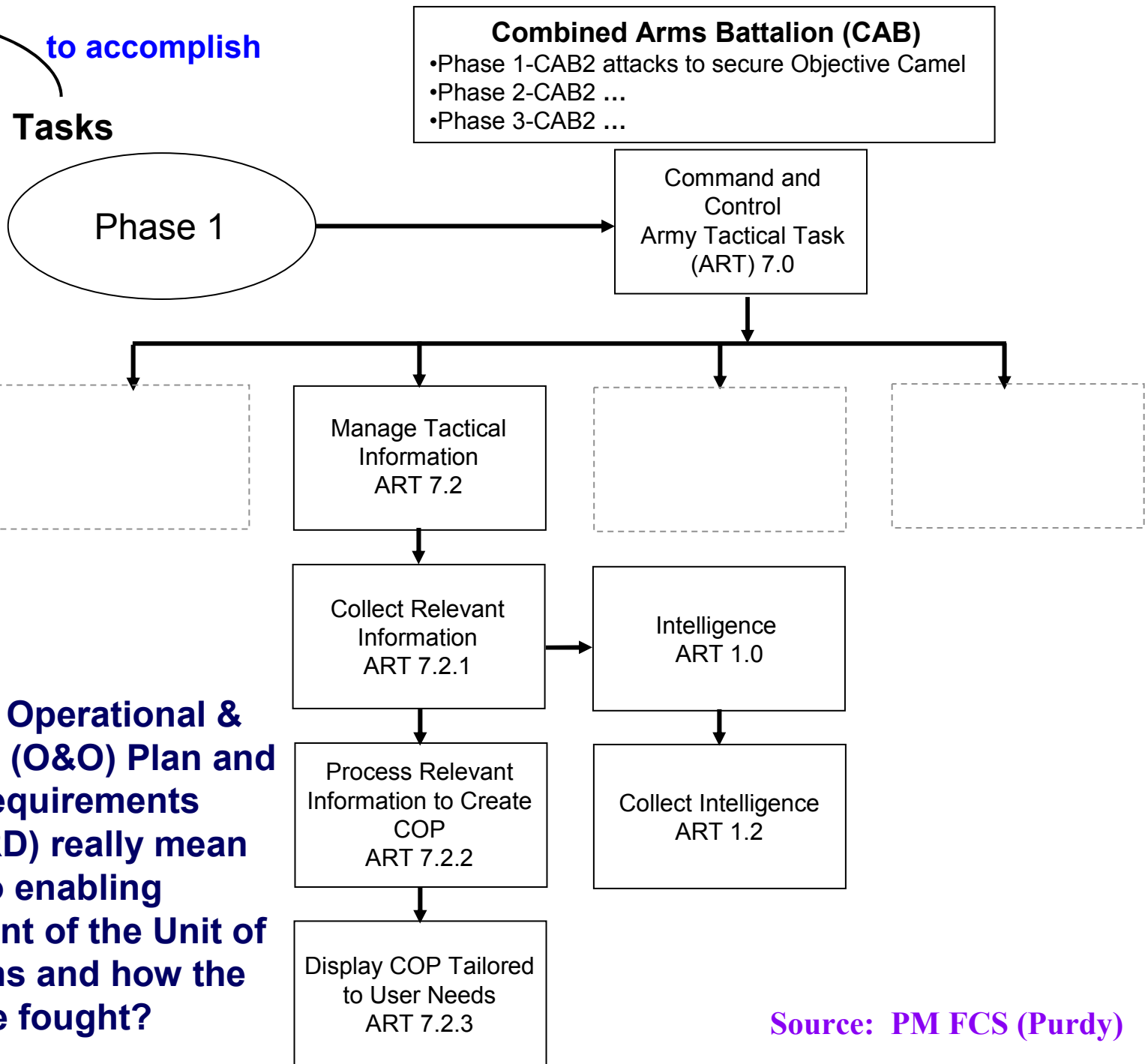

What does the Operational & Organizational (O&O) Plan and Operational Requirements Document (ORD) really mean with respect to enabling accomplishment of the Unit of Action Missions and how the materiel will be fought?

Source: PM FCS (Purdy)

UJTL - AUTL-ORD X-walk

UJTL

- AUTL (UE)

- UA- MSN / Tasks

- CAB MSN / Tasks

- CO MSN/Tasks

- PLT MSN/Tasks

- SQD Tasks

- IND Tasks

Under Construction by TRADOC

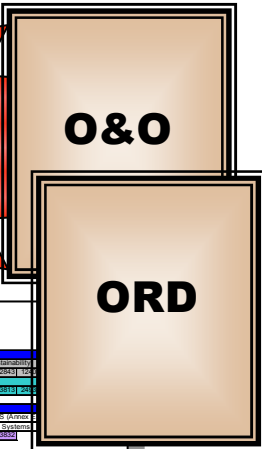

KPP Mapping

Responsiveness		Responsibility		Agility & Versatility		CACE ORD - P&A		Operational Capability		Sustainability	
UJTL	AUTL	UA	CAB	CO	PLT	SQD	IND	ORD	ORD	ORD	ORD
1000	1000	1000	1000	1000	1000	1000	1000	1000	1000	1000	1000

CASR Annex A		Development Annex B		Annex C		CAME		M&A		M&S		M&V		M&W		M&X	
UJTL	AUTL	UA	CAB	CO	PLT	SQD	IND	ORD	ORD	ORD	ORD	ORD	ORD	ORD	ORD	ORD	ORD
1000	1000	1000	1000	1000	1000	1000	1000	1000	1000	1000	1000	1000	1000	1000	1000	1000	1000

Capability Mapped down to a FCS System or the SoS

Unit of Employment

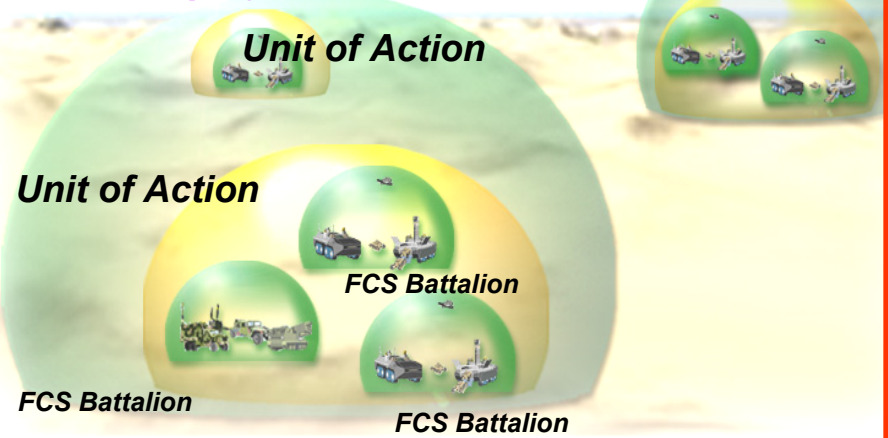

Tasks Identified for Mission Mapped to O&O Capabilities

(What must be done in a test to enable evaluation of capabilities?)

Source: PM FCS (Purdy)

O&O Capabilities

TASK	AUTL Ref #	F12: Enable dissemination of tactical scheme	F15: Enable continuous situational understanding through networked force	F16: Facilitate automatic language translation	F17: Enable information exchange via adaptive, integrated communications	F18: Detect/prevent intruders/malicious software; identify points of intrusion/origin, information compromised/introduced into the network	F19: Enable Positional Navigation (POSNAV)	F20: Enable information management to fuse, monitor and disseminate information to support CC/IR, combat action, decision-making and analysis	F21: Establish an adaptive learning repository to build and manage a library of friendly and enemy DTLOMS and lessons learned	F22: Enable terrain analysis	F23: Integrate synergistic use of ISR to see the full range of operational variables
Manage Tactical Information	ART 7.2		x	x	x	/		x			x
Process Relevant Information to Create a Common Operational Picture	ART 7.2.2		x	/	/	x	/	x	x	x	/
Display a Common Operational Picture (COP) Tailored to User Needs	ART 7.2.3	/	x	x	/	/		/			
ART 7.2.4 Store Relevant Information											
Disseminate COP and Execution Information to Higher, Lower, Adjacent, Supported, and Supporting Organizations	ART 7.2.5	x	x	/	x	/		/			/
ART 7.2.6 Communicate with Non-English Speaking Forces and Agencies											

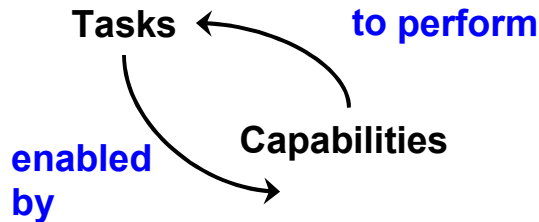

Red with an X = Direct enabler of intent of task
 Yellow with a / = Enables performing task to standard

O&O Capabilities Mapped to Materiel via ORD & PCDs

(What materiel will be assessed to evaluate capability of interest?)

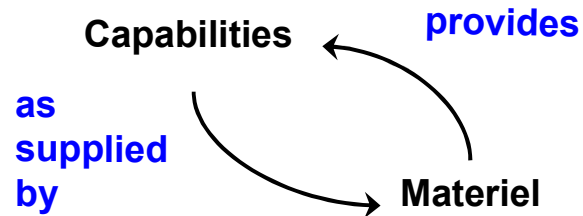

Source: PM FCS (Purdy)

O&O Capability	ORD Reference #	Procurement Control Drawings (PCD)
F15: Enable continuous situational understanding through networked force	2392	786-300151
	2314	786-30093, Integrated Computers; 786-30143, Network Management
	2365	786-30093, Integrated Computers; 786-30143, Network Management; 786-30151
	2661	786-30018, Class III UAV; 786-30019, Class II UAV; 786-30020, Class I UAV; 786-30028; 786-30146, Situation Understanding (SU) SSS; 786-30151
	2869	786-30131, Tactical UGS System; 786-30132, Urban UGS System; 786-30144, C2 Battle Command & Mission Execution SSS; 786-30145, C2 Planning & Preparation SSS; 786-30151
F16: Facilitate automatic language translation	1040	786-30093, Integrated Computers
F17: Enable information exchange via adaptive, integrated communications	1016	786-300144, C2 Battle Command & Mission Execution SSS; 786-300145, C2 Planning & Preparation SSS; 786-300148; 786-300149, Warfighter Machine Interface (WMI); 786-300151; WIN-T; JTRS
	1120	786-30140, Ground Vehicle Communications; 786-30143, Network Management; 786-30149, Warfighter Machine Interface (WMI); 786-30151
	1148	786-30018, Class III UAV; 786-30019, Class II UAV; 786-30020, Class I UAV; 786-30022, Armed Robotic Vehicle (ARV); 786-30025, Small UGV (SUGV); 786-30093, Integrated Computers; 786-30151

Metrics of Interest to the Evaluator

(Do Specifications Convey User Needs Properly?)

KPP 2 Networked Battle Command	COIC	ORD #	Evaluation Measures			Proposed Metrics
		1064	Time to integrate	Time to provide/update COP	Accuracy of information	Y/N-Tactical info and data collected, processed, displayed, stored, and disseminated directs relevant info to the right persons at the right time in a usable format to facilitate SU and decision making
		1073	Message completion rate	Latency	Resolution	% operational data displays that are current
		2314	Time to recover			
		2392	Latency	Accuracy	Resolution	Time between force COP and real world situation, in order to maintain operational info, force status, & capability to respond to emerging situation and/or project branches/sequels
		2406	Probability Correct ID	Accuracy	Processing time	
		3158	Latency	Accuracy	Scalability	
	6.c.1- Information assurance ...					
		2501	IA metrics			
		2395	Compliance (Y/N)			
		3710	Compliance with Information Security Requirements	IA Metrics		

Red=Band 1, FCS KPPs; Blue=Band 2, Critical Requirements that underpin the KPPs; Green=Requirements that underpin the COICs

Sample Task Set Applied to Generic OT Model

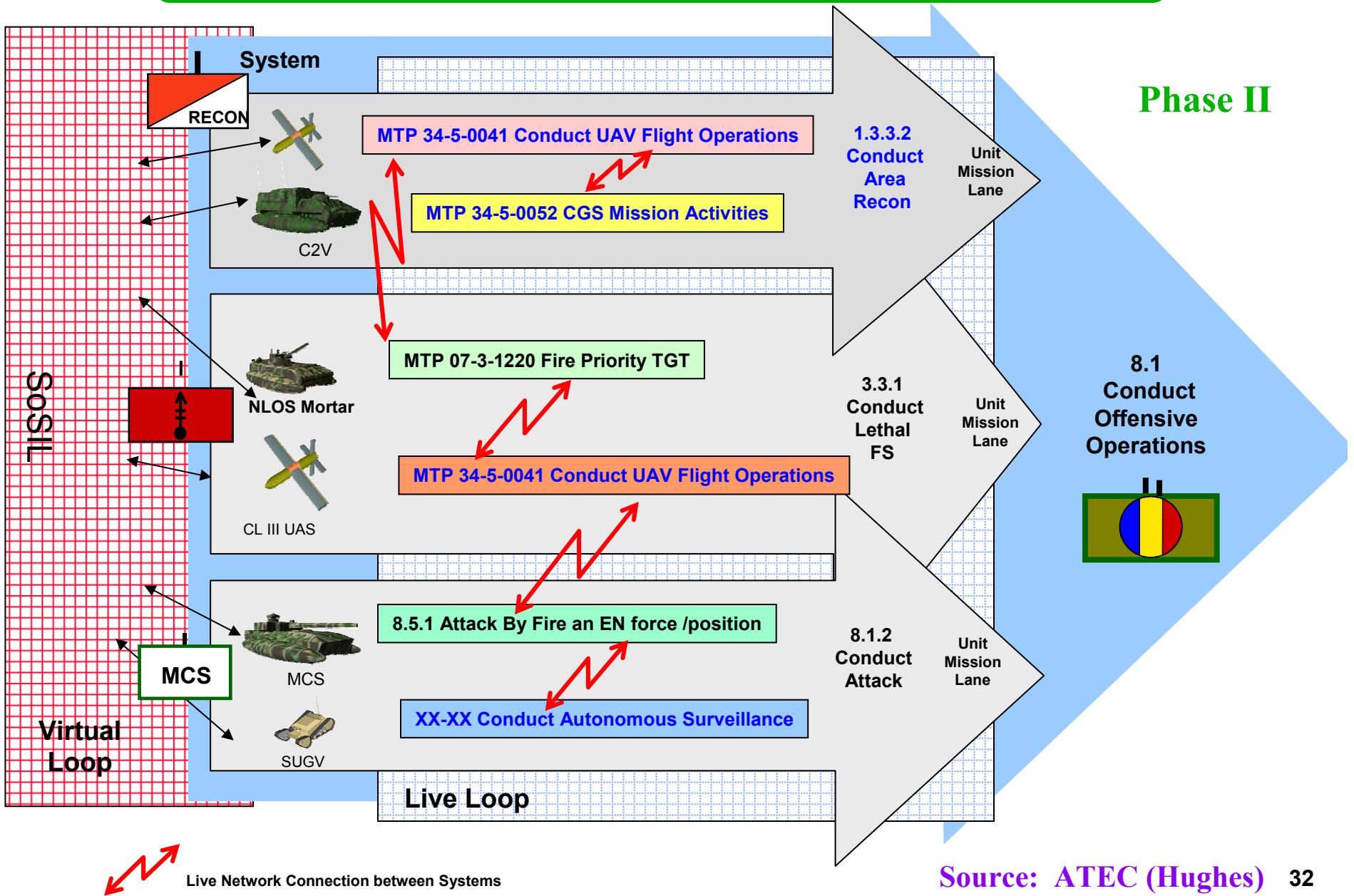

Attack Operations Package

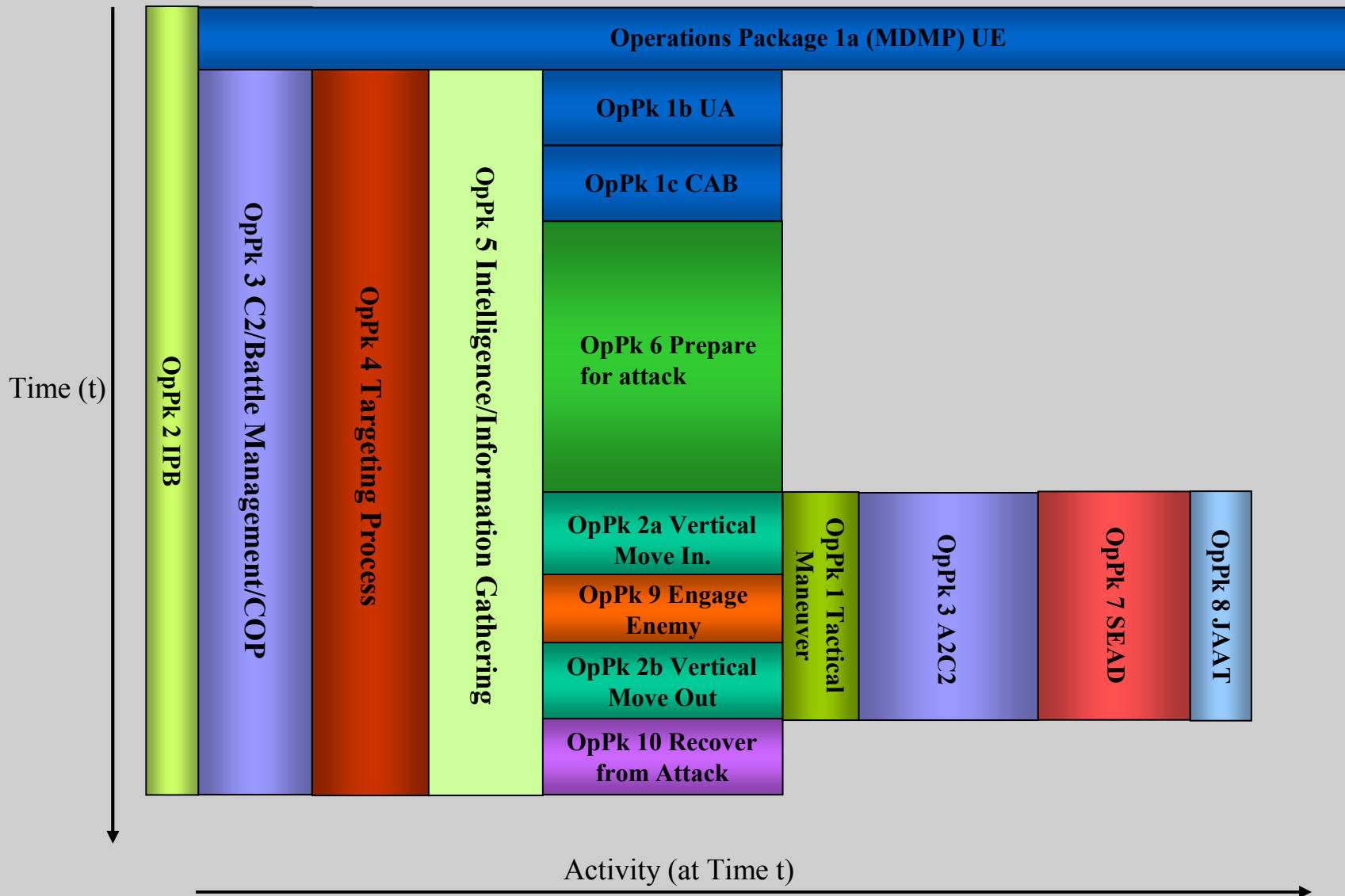

Attack Operations Package Sequence

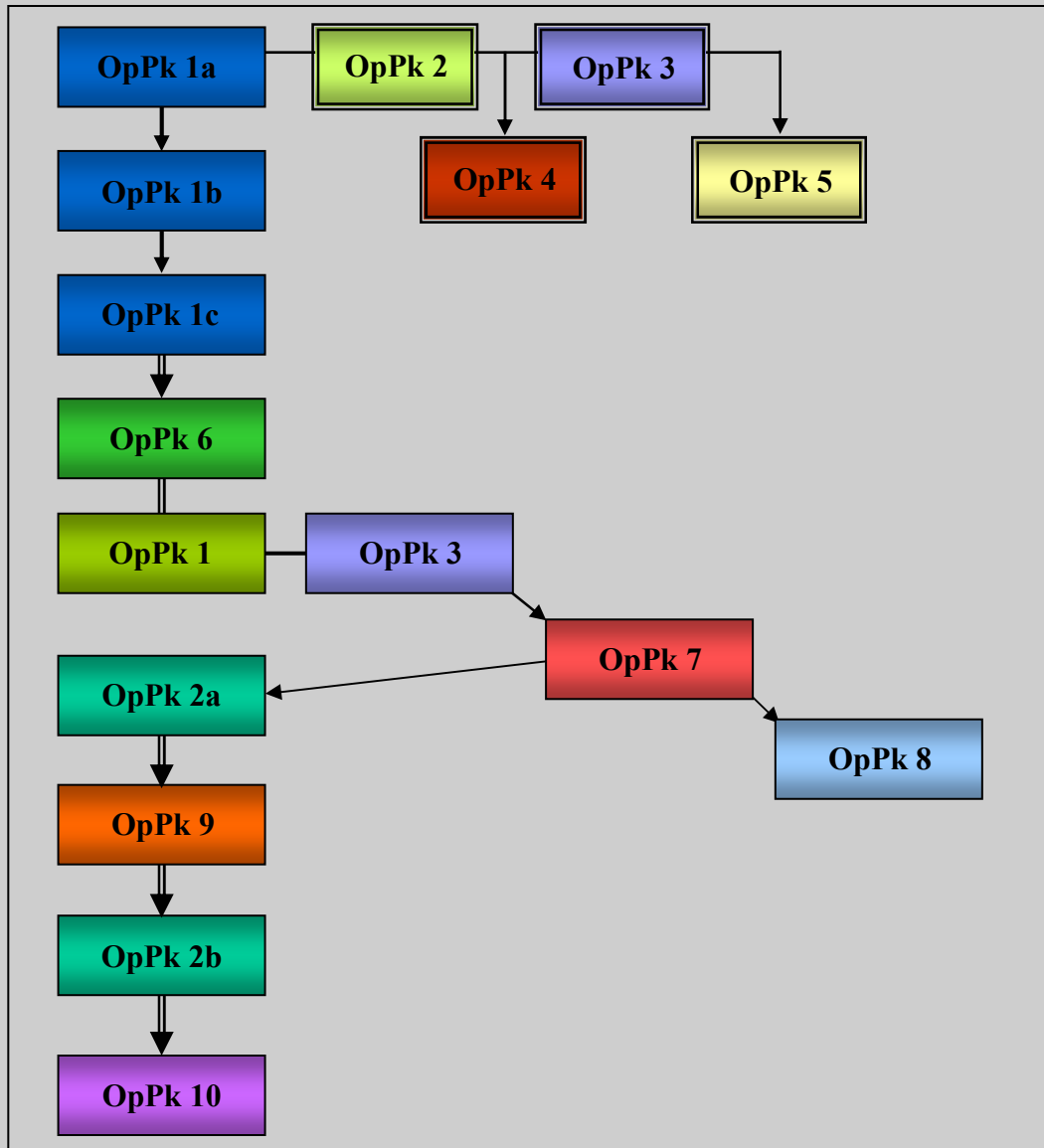

- Start Operations Package 1a first.
- OpPk 2 and OpPk 3 are continuous and feed into OpPk 1a, b, and c
- OpPk 1b, 4 and 5 begin during OpPk 1a.
- OpPk's 4, and 5 are continuous. OpPk 1c begins during OpPk 1b.
- OpPk 6 follows OpPk 1c.
- OpPk 1 and OpPk 3 begin when OpPk 6 ends and end when OpPk 10 begins.
- OpPk 7 begins after OpPk 1 begins and before OpPk 2a begins and ends when OpPk 2b ends.
- OpPk 2a and OpPk 8 begin during OpPk 7.
- OpPk 9 begins after OpPk 2a.
- OpPk 2b begins after OpPk 9.
- OpPk 10 begins after OpPk 2b
- Attack Operations Package ends when OpPk 10 is complete

MoE: Country of Interest conventional military forces prevented from re-entering capital and interfering with main effort.

Operations Package 3 (C2/Battle Management)

MoE: Attack planning, coordination and execution is not adversely affected by inaccurate or outdated information concerning environmental conditions, friendly unit location and status or reported enemy activity, location, strength and intentions. (Y/N)

Sequence #	Task #	Task Title	MoP	Unit
3.8	ART 7.3.2.3	Conduct risk management	1) No offensive tasks executed that exceed maximum residual risk established by commander. 2) No casualties as a result of failure to manage risk.	All
3.9	ART 7.6.3	Make adjustments to resources, concept of ops or mission	Adjustments made to exploit opportunities or resolve problems occurring during execution effectively. (Y/N)	Commander
3.10a	ART 7.5.4	Revise and refine the plan	Revision and refinements to the plan completed in less than one third of time available before execution.	Commander and Staff
3.10b	ART 7.6.1.2	Adjust graphic control measures	1) Adjustment of graphic control measures accurately reflected changes in METT-TC (w/in 100 meters). 2) Lag time between operations and adjustment of graphic control measures (<5 minutes).	Operations and Intel Cell

Vignette #2- Urban Operations

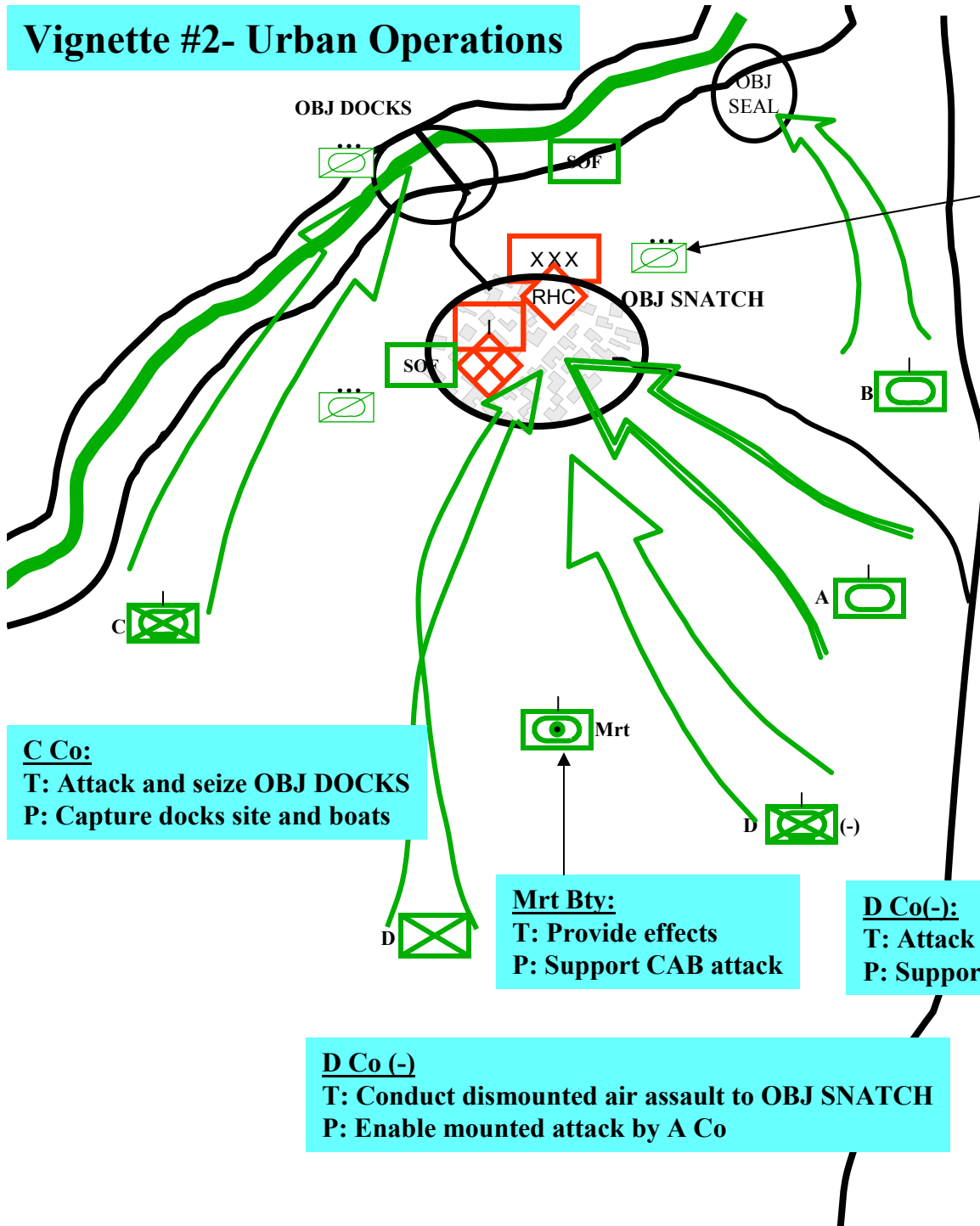

1st CAB, 1st UA attacks to seize RHC at military base

Recon Trp:
T: Conduct zone recon
P: Identify and locate RHC

B Co:
T: Seize OBJ SEAL
P: Protect the flank of ME attack

A Co: (ME)
T: Attack and seize, enabled by dismounted attack, OBJ SNATCH
P: Capture enemy high command personnel

C Co:
T: Attack and seize OBJ DOCKS
P: Capture docks site and boats

Mrt Bty:
T: Provide effects
P: Support CAB attack

D Co(-):
T: Attack and seize OBJ SNATCH
P: Support A Co (ME)

D Co (-)
T: Conduct dismounted air assault to OBJ SNATCH
P: Enable mounted attack by A Co

UA 1 T&E Summit III (Urban Asslt)

Mission: At H+88 CAB 2 (ME) attacks to defeat Rebel forces vic OBJ CAMEL in order to prevent Rebel forces from reinforcing Baku. CAB 1 defends vic OBJ KNIGHT (oriented south) in order to protect CAB 2 and CAB 3's attack northeast. CAB 3 follows and supports CAB 2 and is prepared to seize OBJ KNIGHT on order.

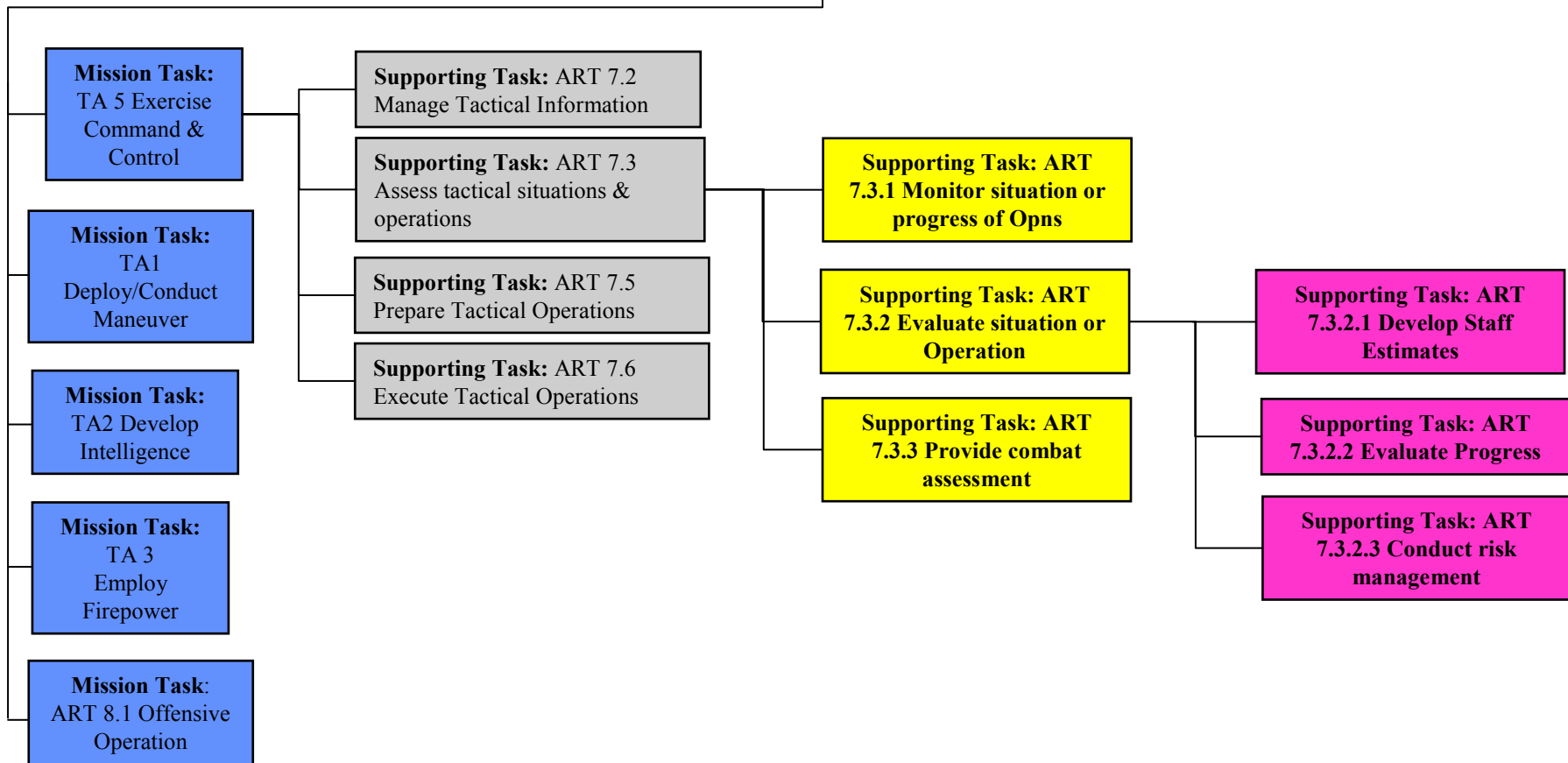

Security BDE A



Task: establish 7 secure routes to the north
Purpose: provide secure transit for IPT leadership and support deception

Task: establish 6 secure routes to the north
Purpose: provide secure transit for IPT leadership and support deception

Task: establish 5 secure routes to the north
Purpose: provide secure transit for IPT leadership and support deception

Other tasks:
Provide SHORAD
Provide conveyances
Establish safepoints

Security Brigade A



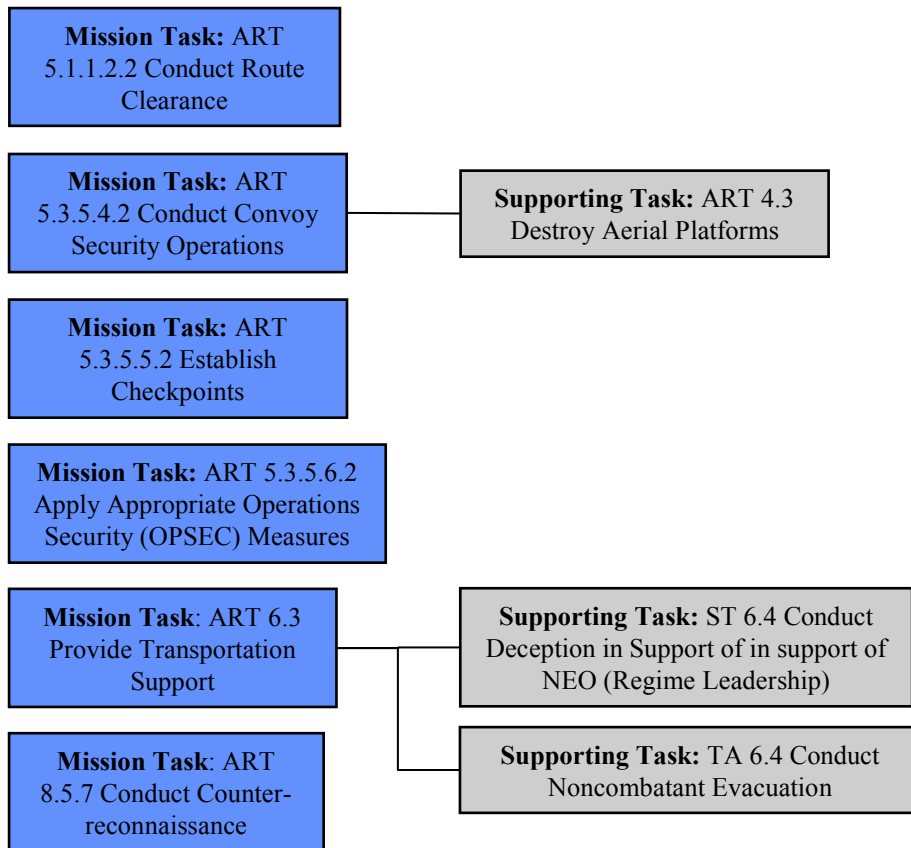

Mission: Secure a number of routes out of the city, conduct false leadership convoys, on order evacuate the IPT leadership to a designated secure location. Prevent the capture or destruction of the IFP leadership.

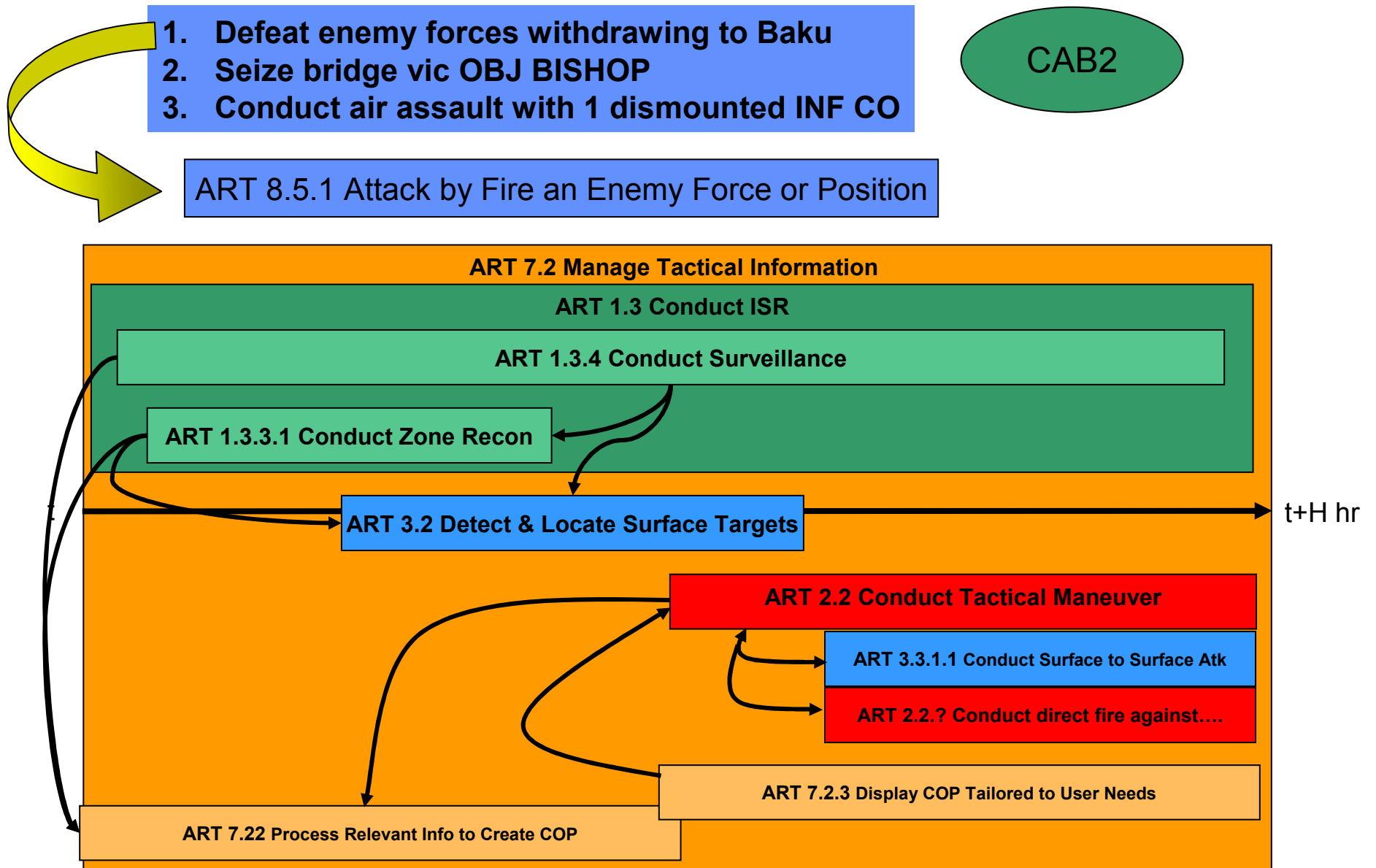

Chronological and Data Input of Task Execution

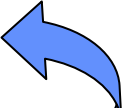
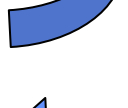

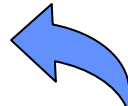
Relating Effects to Utility

Combatant Commander	Establish Conditions for Restoration of Legitimate Pro-Western Government	
CTF	Isolate Capital Deter/Prevent Incursions from Hostile Country forces	
UE	Secure Objectives vicinity of Capital (Surround) Secure Objectives along PL Limit (Block)	
UA	Delay Hostile Country forces for six hours Suppress enemy air defenses along air axis Jam AD radar and C2 network of enemy forces	
Plt/Co/Btry	Be in position ready to fire 2 hours prior to F hour	

Condition: A chemical mine has been detonated by unknown forces along a portion of the main East-West LOC. One of the MLRS Batteries of the Divisional MLRS BN is contaminated at _____ time. Four of the six launchers in the BTRY have been contaminated. The MLRS BTRY was in the process of moving to designated position areas in order to be able to deliver rockets against Air Defense targets as part of the SEAD plan. The battery will need two hours to reach the designated position areas and be ready to fire. The SEAD plan is scheduled to begin at _____ time.

Decontaminate Personnel and Systems
ART 5.3.2.2

Conduct Operational Decontamination Operations
ART5.3.2.2.2

Mission Utility: Unit in position and ready to fire NLT _____.
SubMeasures: 1) > 80% of unit is CBT effective.
2) Chemically contaminated vehicles/personnel considered combat ineffective

Contam. Unit's Leader determines extent of contamination / establishes decon priorities

Contam. Unit submits decon request to higher HQ via FM

Newly deconned unit rejoins forces prepared to continue combat operations

- Contam. Unit performs unmasking procedures when no hazards are detected
- Adjusts MOPP level as required

Contam. Unit

Requests replacement MOPP gear

NBCC

Contam. Unit's higher HQ Chem Staff coordinates with supporting elements

- Contam. Unit leader selects decon site
- Battalion PDDE crew and other supporting elements arrive at linkup point
- Units prepare for Operational Decon
- Contam. Unit vehicles process through wash-down site
- Contam. Unit personnel conduct MOPP gear exchange
- Battalion PDDE crew cleans and marks decon site

Submits NBC 4 to higher HQ

BN PDDE Crew

Other Elements

Enemy forces remain south of PL and remainder of CJFLCC forces secure remaining objectives. Capital is isolated.



Coalition Strategic Objective in support of UN:

Return legitimate government to power while ensuring territorial security of country and **Detering Country Y aggression and involvement in Country X**

Enemy is delayed long enough for brigade to secure Objective South and occupy defensive positions.

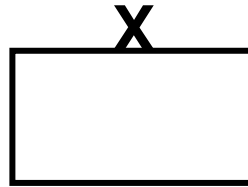

Coalition Military Objectives:

Isolate Country X capital to facilitate restoration of legitimate government.

Attack helicopter battalion conducts deep attack without losing a helicopter to enemy air defenses.

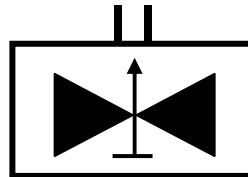

O/O CJFLCC deploys into the JOA to secure and defend LOCs. **Attacks to defeat IFP forces, and conducts operations to deter Z incursions.**

MLRS Battery arrives in position and is ready to fire assigned targets for SEAD plan.

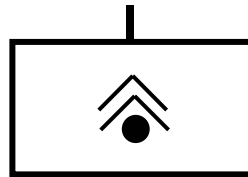

O/O CTF conducts operations to defeat IFP conventional military and deter Country Z involvement in Country X.

MLRS Battery deconned in 6 hours

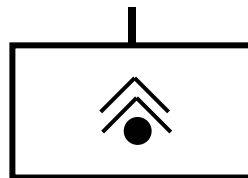

Conduct offensive operations in the JOA
OP 1.2.5

MVR

FS

M/CM/S

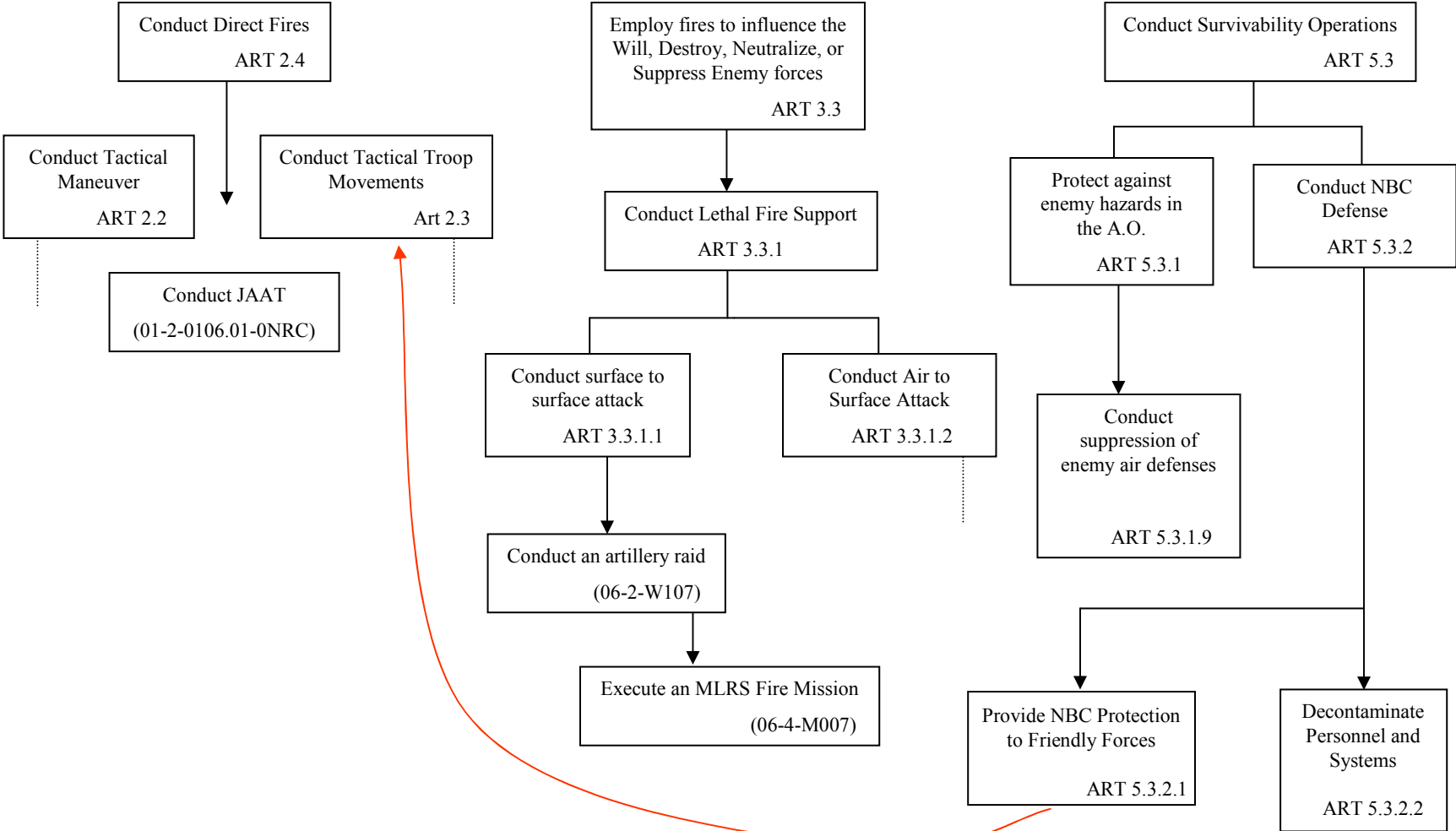

Conduct offensive operations in the JOA
OP 1.2.5

MVR

FS

M/CM/S

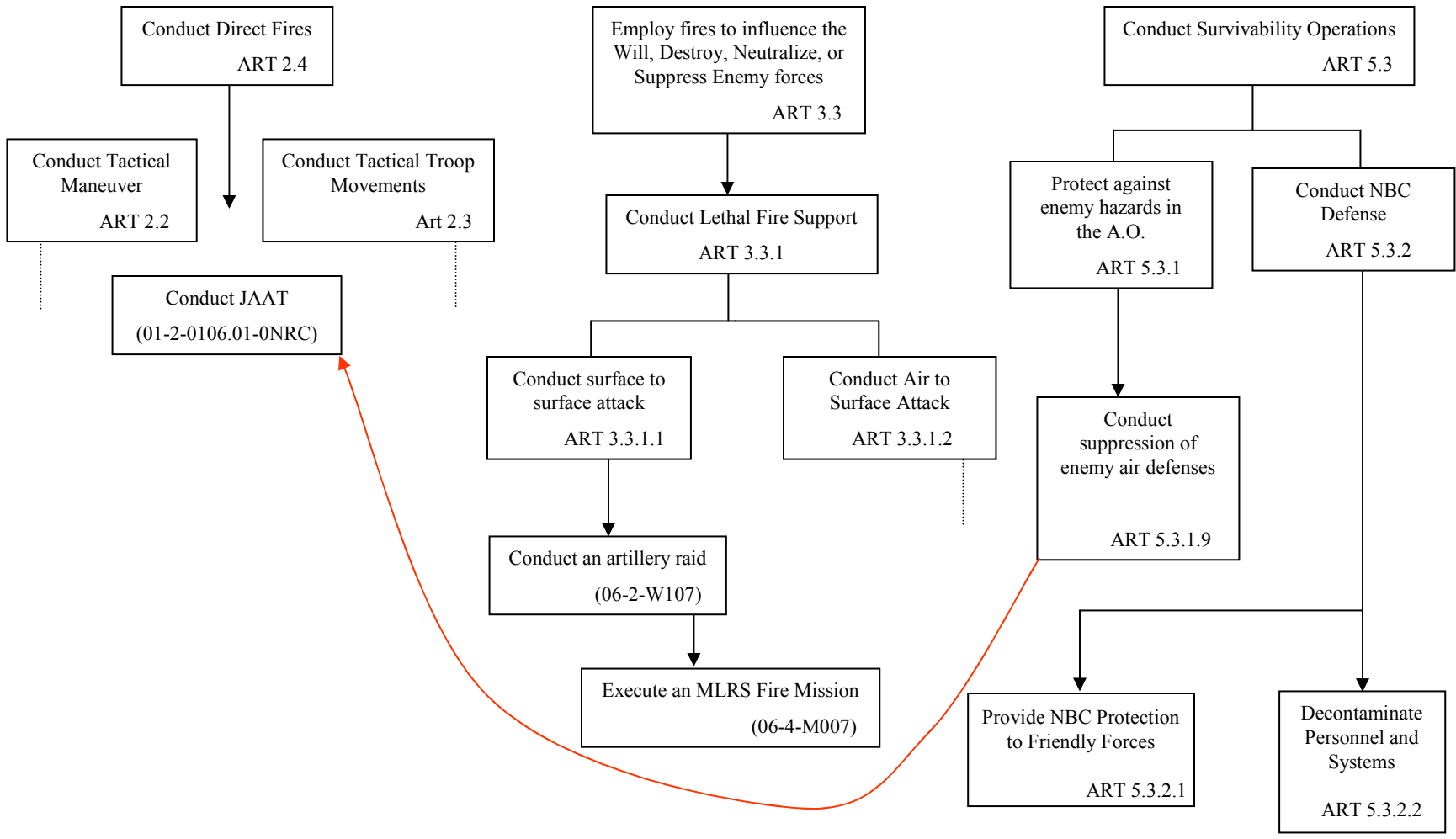

Conduct offensive operations in the JOA
OP 1.2.5

MVR

FS

M/CM/S

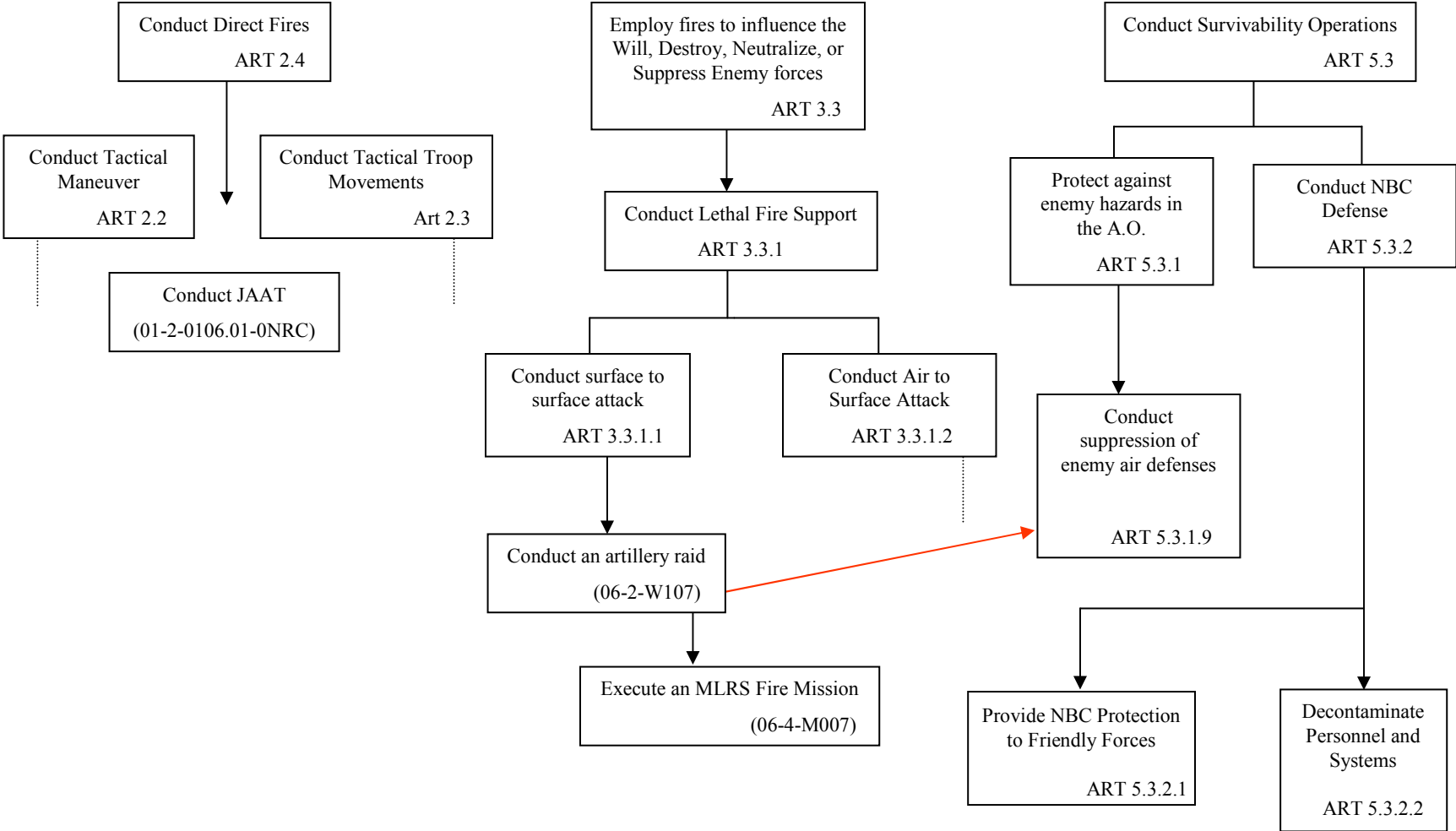

Conduct offensive operations in the JOA
OP 1.2.5

MVR

FS

M/CM/S

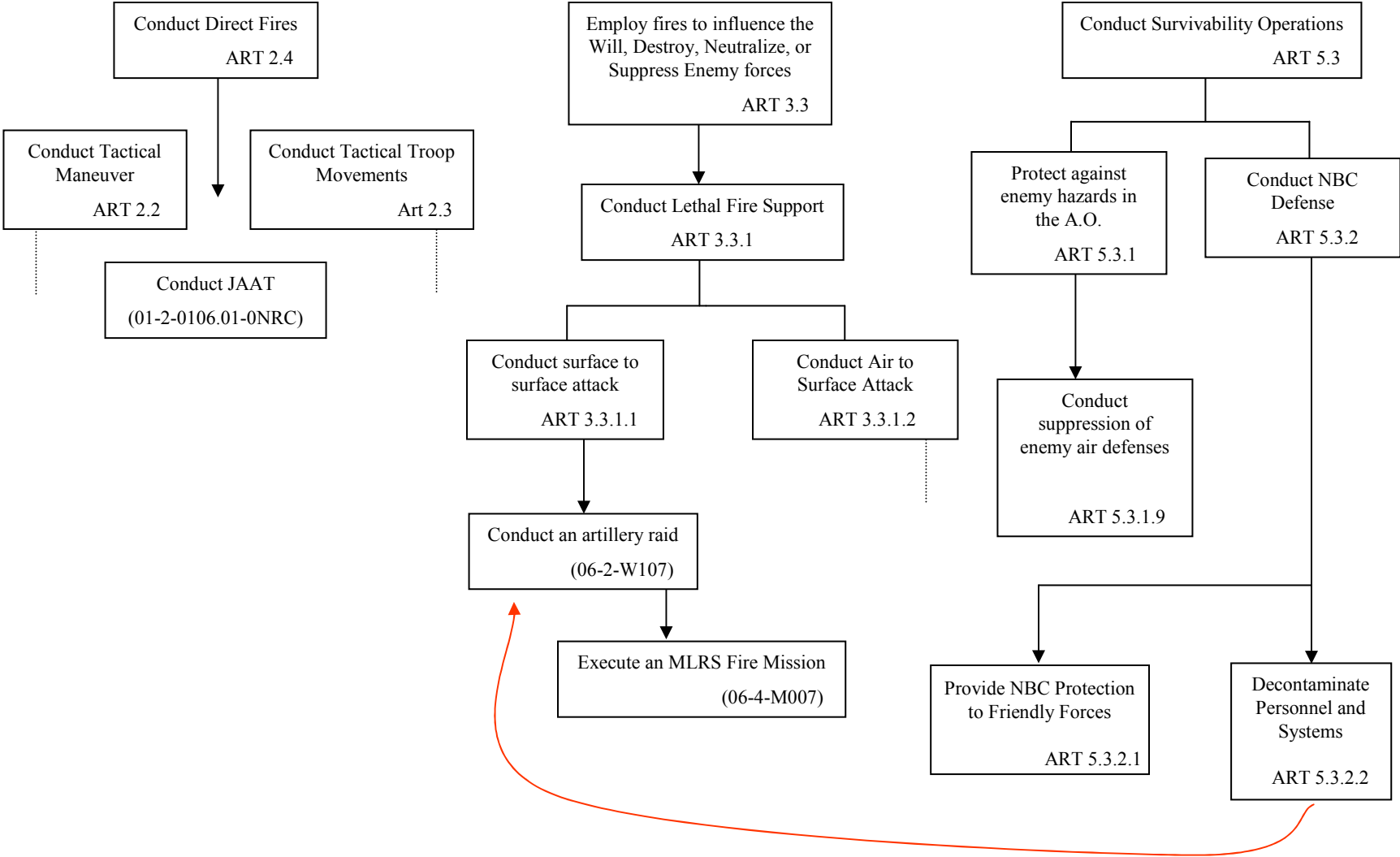

MMF Application – Key Tasks

