



Avon Protection Systems, Inc. Design and Development of New Advanced US Government Military Masks and Filters

Wayne Scheurer
JSGPM Program Manager



Joint Service General Purpose Protective Mask (JSGPM) XM50/51



The JSGPM is the next generation ground/ship, and combat vehicle chemical and biological protective mask replacing the USAF and USN MCU2P series protective mask and the USMC and USA M-40 series protective mask.



USSOCOM M53



The USSOCOM
M53 Mask System
will replace the M45

USSOCOM Drives the Design

- Tremendous emphasis on weapons and sighting systems interface
- Fit all intended users
- Enhanced comfort for prolonged missions
- Amplified voice and radio communications
- Integrate with SCBA, PAPR and CCBA systems



M53 Key Performance Parameters

- Provide the wearer facial, ocular, and respiratory tract protection from CB agents, radioactive fallout particles, and TIC/TIMs.
- Provide equal to or better protection, when compared to the C2A1 filter
- Permit unobstructed and undistorted forward vision.
- The mask shall provide a durable drinking capability.
- Be compatible with current and co-developmental SOF CB garments.
- Mask will be able to use an external voice amplification device and an internal microphone.

Design Approach

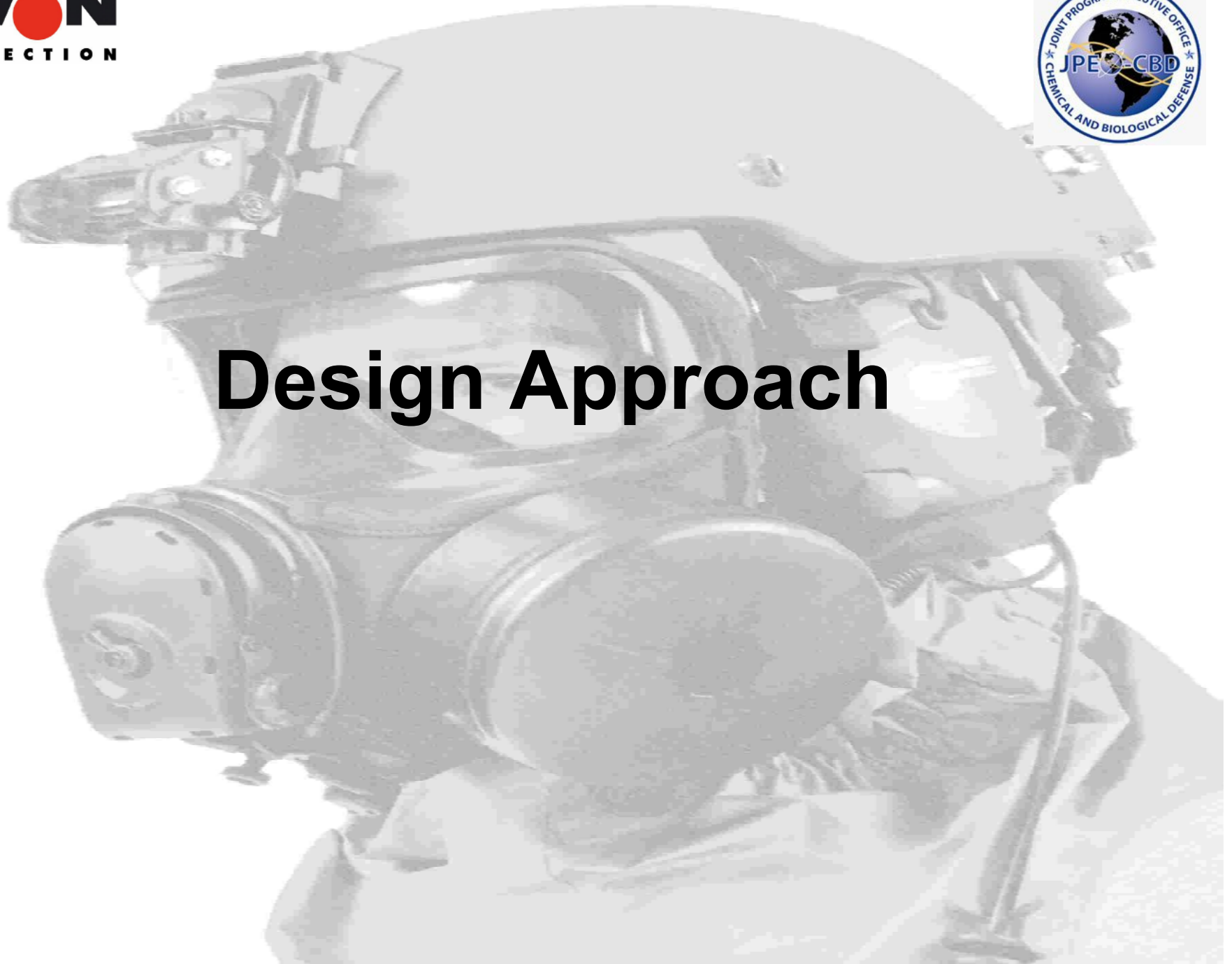

MILESTONE	ACTIVITY
Post Award Conference PAC October 2002	<ul style="list-style-type: none"> •Outline program •Review specification •View list of critical equipment
Early User Assessment (EUA) April 2003	<ul style="list-style-type: none"> •Produce mask prototypes •Conduct user trials •Risk Matrix
Critical Design Review (CDR) August 2003	<ul style="list-style-type: none"> •EUA complete •Engineering baseline approved •Draft repair level analysis
Transition to Production Readiness Review (TPRR) Feb 2004	<ul style="list-style-type: none"> •Draft FMECA •Draft Safety and Health Hazard Analysis
System Delivery April 2004	<ul style="list-style-type: none"> •Tooling manufactured •Operation Trials and Evaluation specification prepared •Production processes planned •Draft manual and training material complete
System Design and Development SDD complete March 2005 Milestone C (Government approval for production)	<ul style="list-style-type: none"> •Tooling and assembly and test equipment approved •400 Mask systems assembled and delivered •Training complete •Draft OEM Manual complete

Post Award Conference /Early User Assessment

Post Award Conference – Objectives:

- To establish and agree a common understanding regarding the requirements of the Statement of Work and Product Description.
- To review critical equipment item list
- The key performance characteristics along with System Description and General Tasks defined in the Product Description would form the design strategies for the program



System Description & General Tasks (EUA)

System Description:

- The NBC IPM is a lightweight, positive-pressure capable, protective mask incorporating state-of-the-art technology improvements for use in direct action missions. Specifically, it provides improved protective capability against emerging CBR threats, better visual field-of-view, closer shooter cheek-to-stock weld compatibility, and a more comfortable fit for longer duration wearing.



System Description & General Tasks (EUA)

General Tasks

The contractor shall design, develop, fabricate, test, and demonstrate a production-representative JSGPM SOF Variant in accordance with this SOW and the Product Description. The System consists of: a face piece having an integral single-piece lens, head harness, a single General Purpose filter together with a Particulate filter that address a variety of threats, a voice-amplified electronic communications device, a variable exhalation resistance valve, nose cups, eye lens outserts, optical correction capability, a drinking device coupler, a protective hood, and a water-resistant carrier. The contractor shall maximize the use of JSGPM design features, materials, manufacturing processes, and sustainment concepts in the system to optimize program cost efficiency, and effectiveness. The contractor shall exercise total system performance responsibility (TSPR).

Joint Services General Purpose Mask XM50/51



- The JSGPM program will provide an overall 50% improvement against the current equipment capability and cost including:
- Improved performance against CB agents, Toxic Industrial Materials and radioactive particulate
- Improved field of view
- Improved compatibility with interfacing equipment
- Reduced weight and bulk
- Significantly reduced breathing resistance
- Reduced in life cost

JSGPM Design Concepts



JSGPM Visor



Sight correction



Weapon sighting



Visor
Outserts

JSGPM Conformal Filters



- **Supplementary additional TIC'S and TIM'S**
- **Enhanced compatibility with personal equipment**

M53 Filter Concept

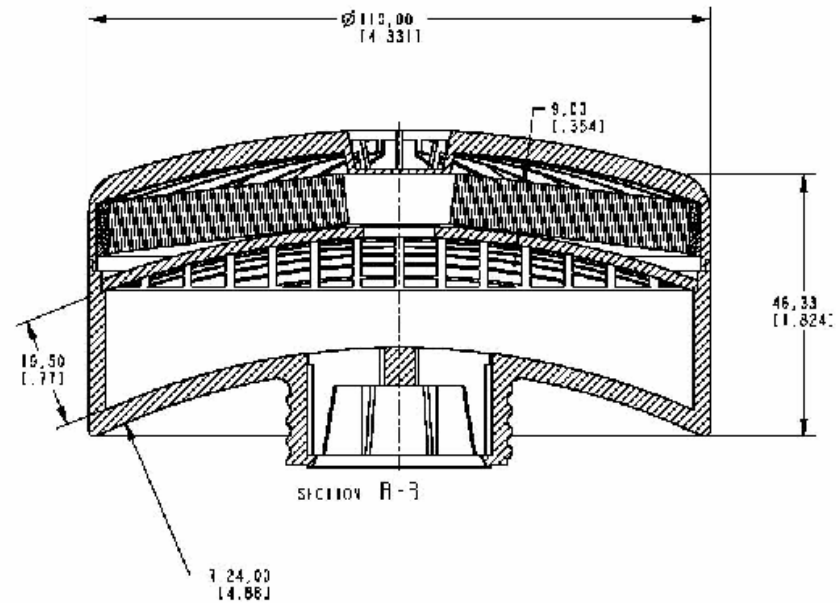
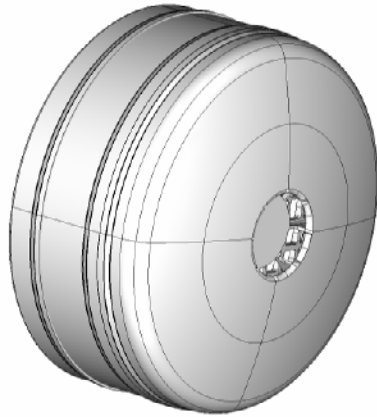

**Conformal filter
design developed for
JSGPM**



M53 Specific Requirements

- Single sided filter with left and right capability
- Be compatible with SCBA, PAPR and CCBA
- Provide voice amplification
- Available in 4 sizes with interchangeable nose cups
- Provide a protective hood for head and neck protection

M53 Prototype

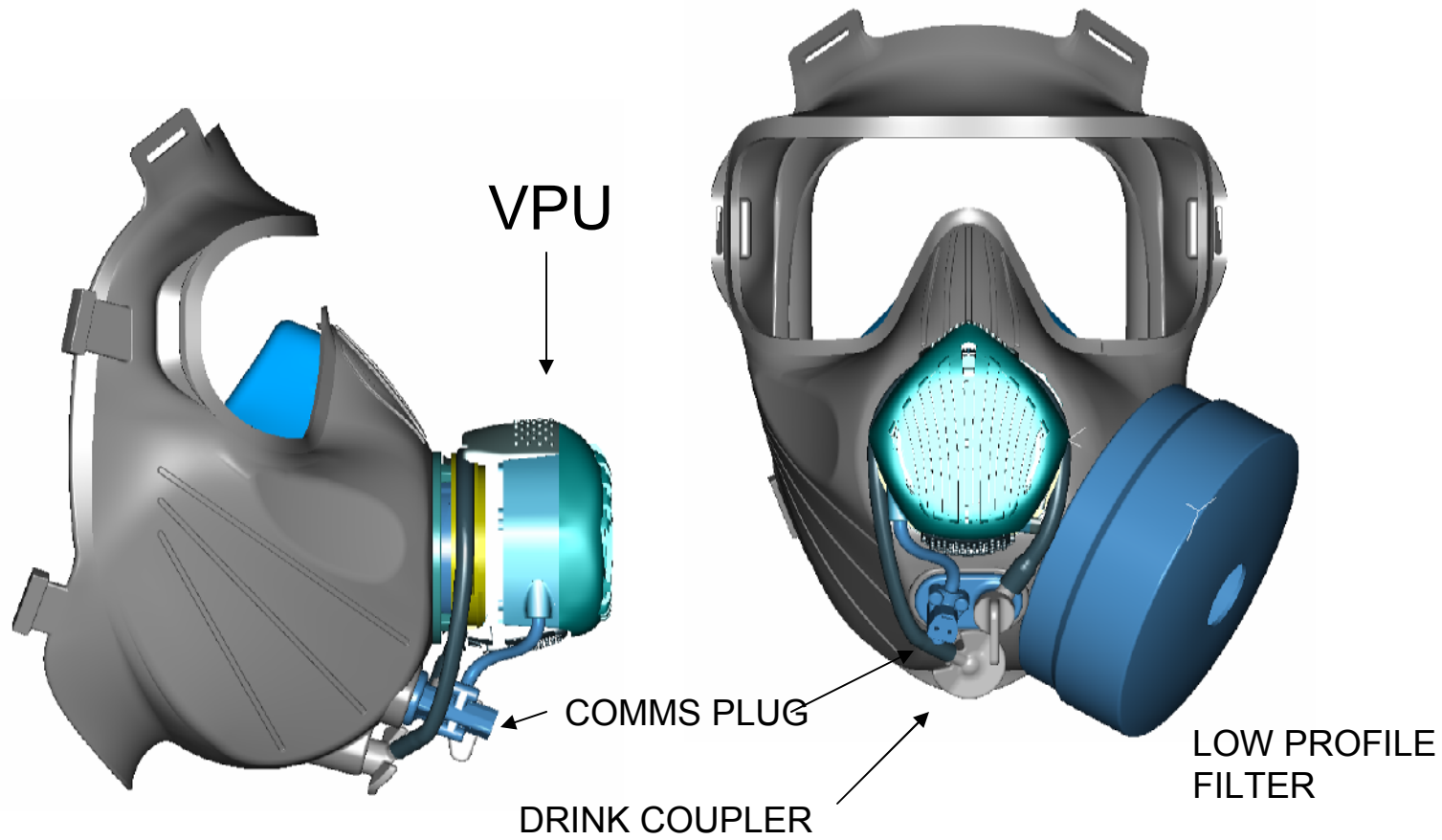

M53 Prototype

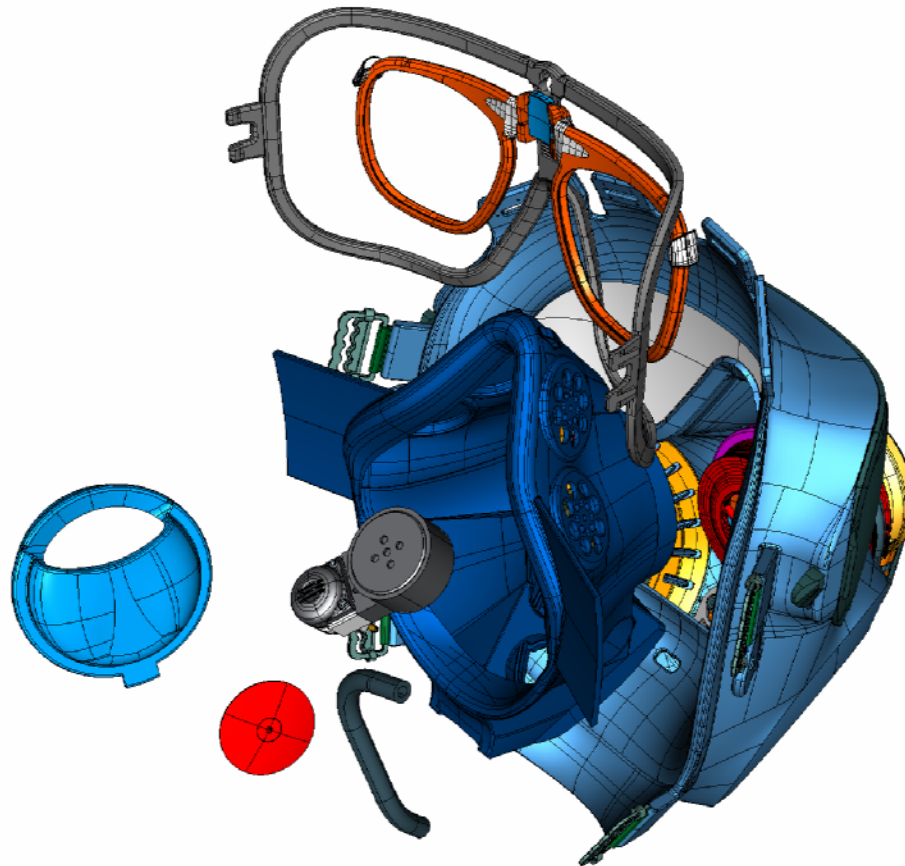



Initial Testing Phase

Early User Assessment (EUA)



Early User Assessment (EUA)

- High Quality Hand Built Prototypes to demonstrate the design concept
- USSOCOM War Fighters Operationally tested the mask to validate the design
- Five days of intense testing encompassing as many operational scenarios as possible
- Avon was a present at the testing to investigate the issues as they happened



EUA Test Protocol

- Introduction
- New Equipment training (NET)
- Full ensemble, Primary and Secondary Fire in Negative Pressure Mode
- Full ensemble, Primary and Secondary Fire in Blower Mode
- Full ensemble, Primary and Secondary Fire in SCBA Mode
- Evaluate Drinking System
- Communication and Voice Projection Unit (VPU)
- Long-Range Fire
- Activities were conducted during day and night
- Interface with as much co-developmental equipment as possible
- Final Assessment

Early User Assessment Results

- Test participants expressed positive feedback of the XM53 prototype.
 - Excellent Field of View
 - Comfort
 - Compatibility with weapons systems
- Negative Feedback included:
 - Eyelens fogging
 - Protruding Voice Projection Unit
 - Close proximity of communication port and drink tube connections
 - VREU Design



Early User Assessment Post Test

- All data collected was jointly reviewed
- Avon prepares for the next phase of the development



Critical Design Review



Critical Design Review

- Variable Resistance Exhalation Unit (VREU)
- Voice Projection Unit (VPU)
- Mask Configuration
- Nosecup Design
- Hood Design

Variable Resistance Exhalation Unit (VREU)

- Robustness
- Simplification of design
- Reduce profile

VREU Modification

EUA Design

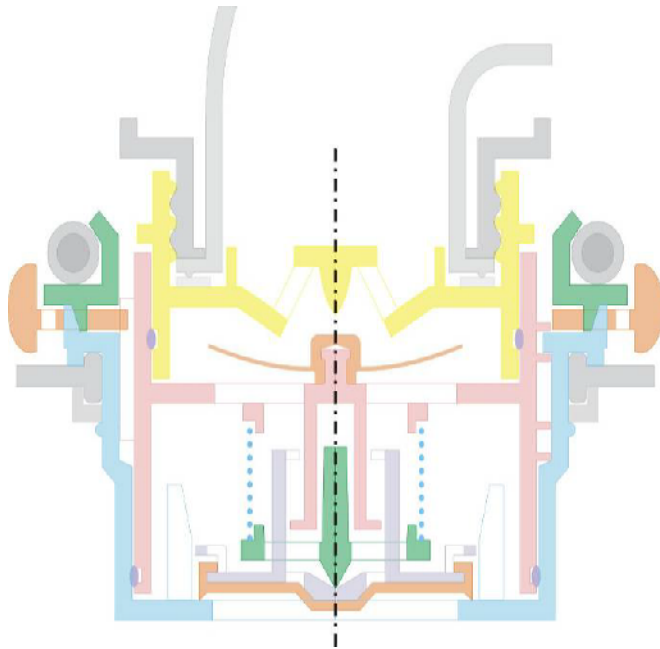

New Design

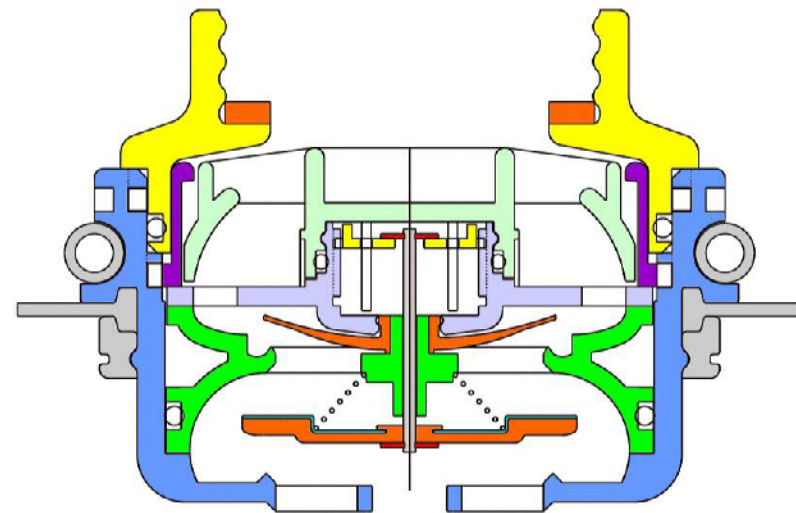

Voice Projection Unit (VPU)

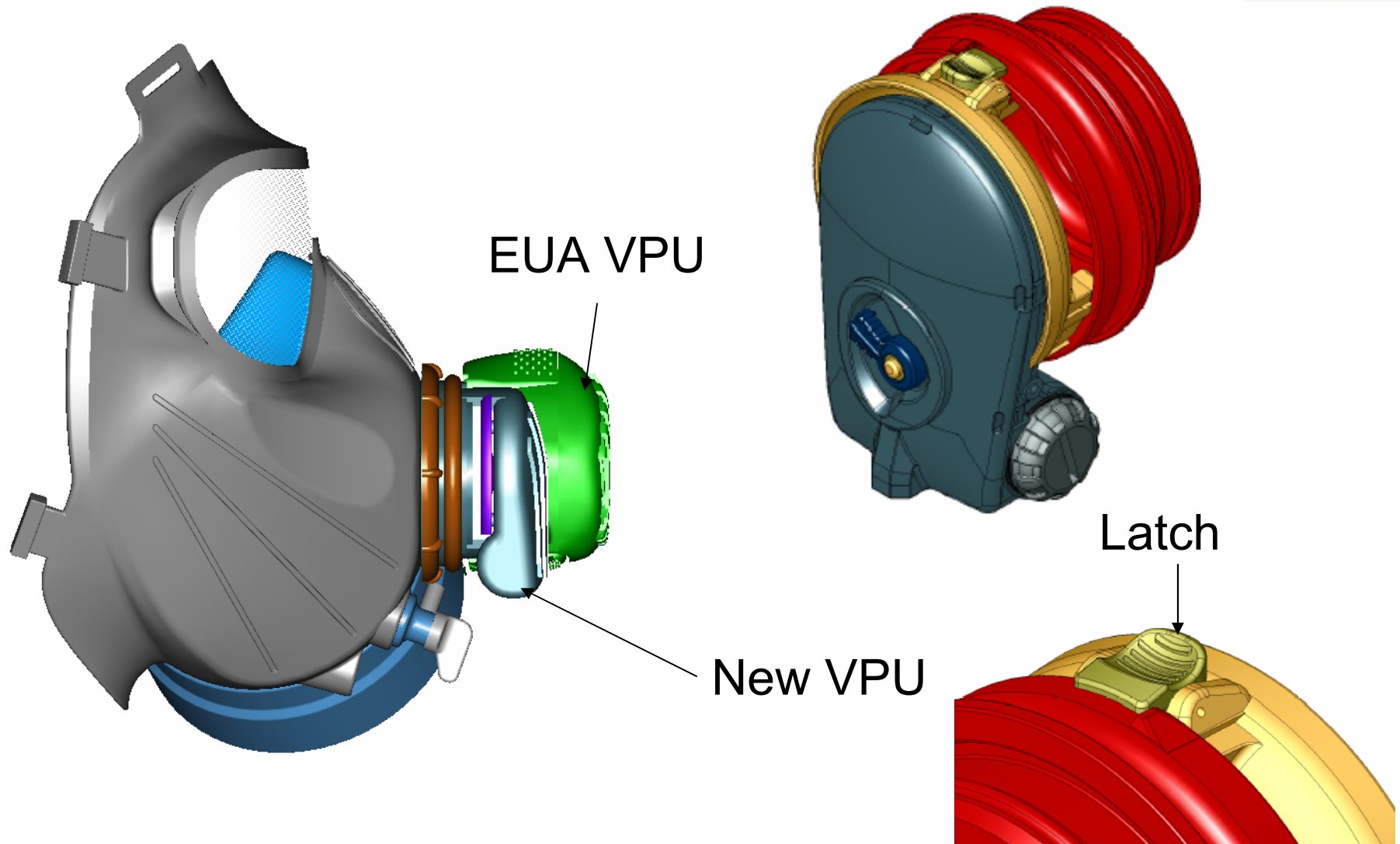

Mask Configuration EUA

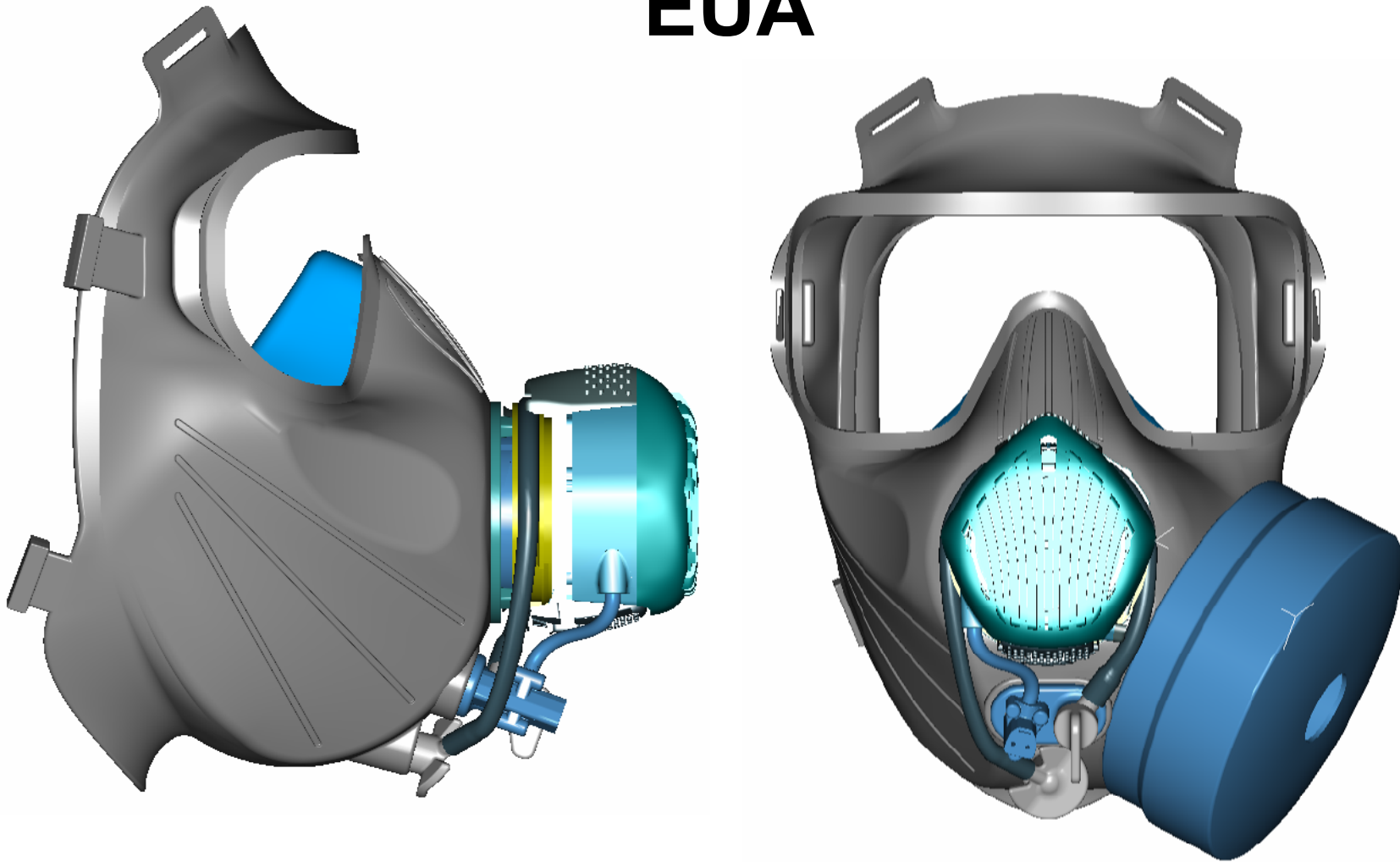

Mask Configuration Rejected Proposal

EUA

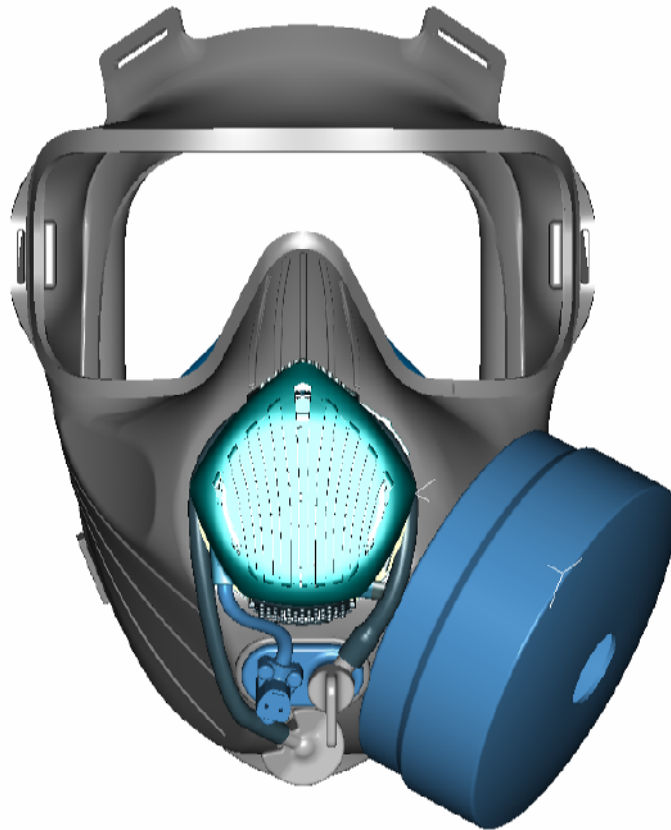

Proposal

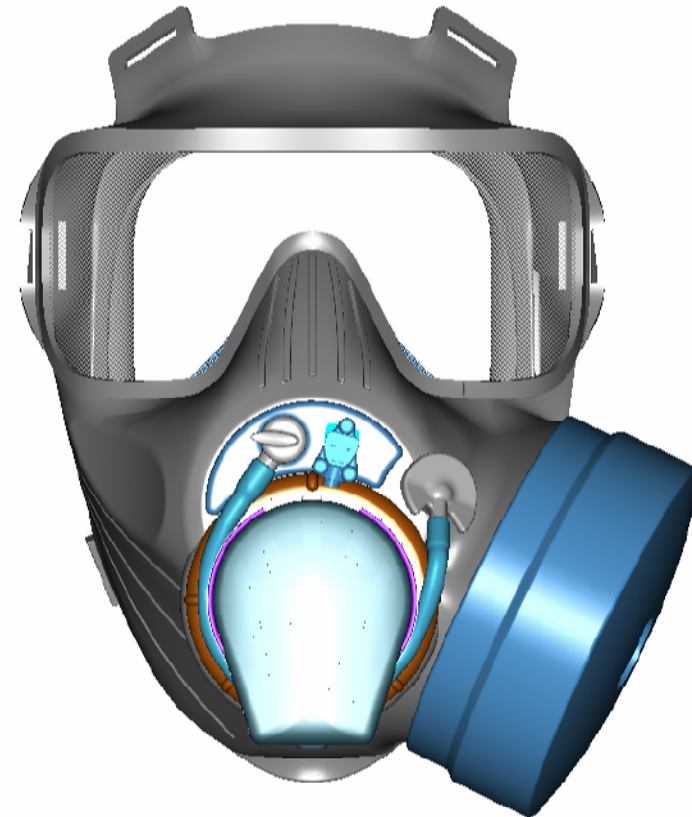

Mask Configuration Approved Design

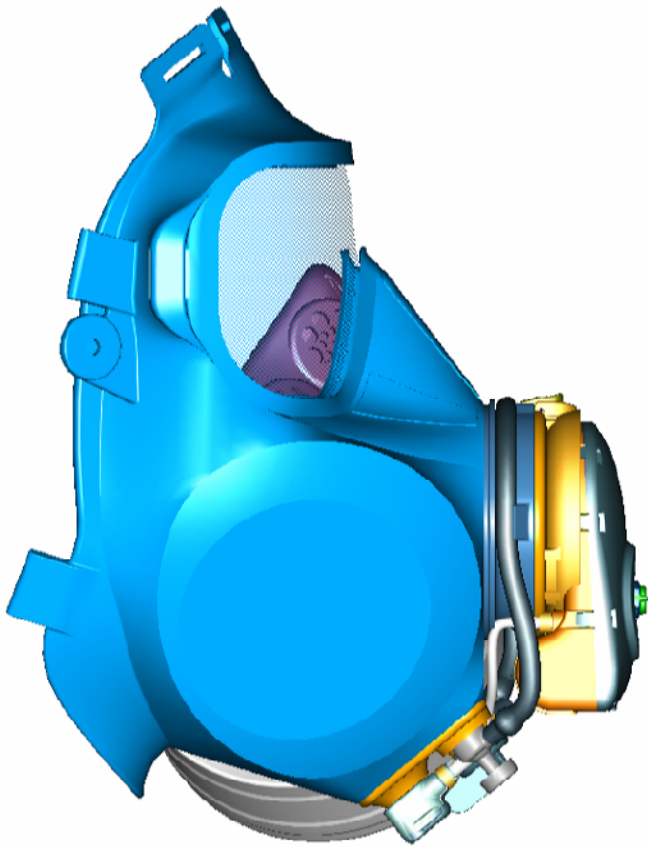

Nosecup Design

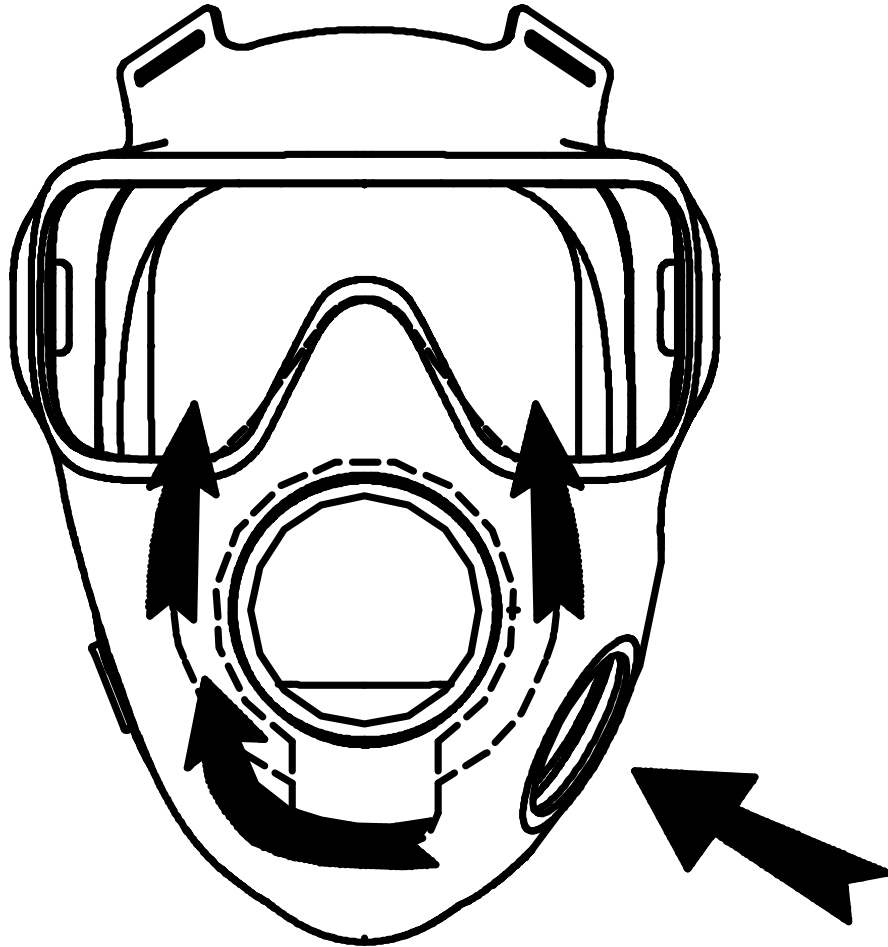

Inhaled air directed
over visor

Nosecup CDR evaluation

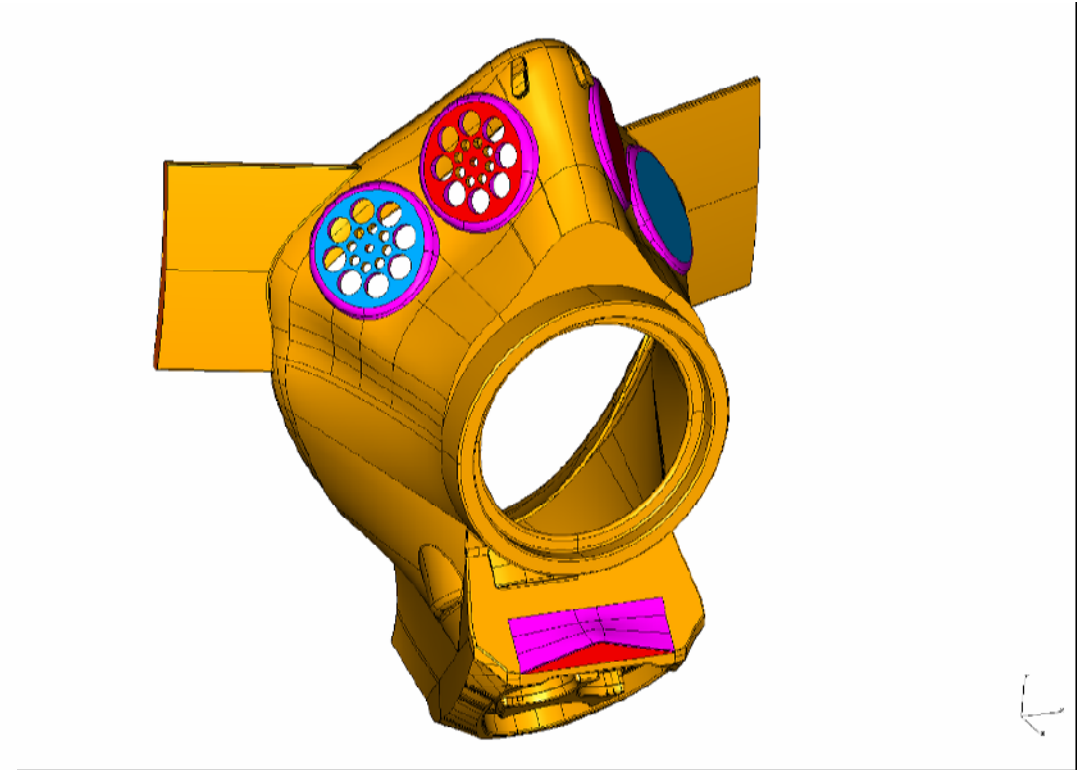
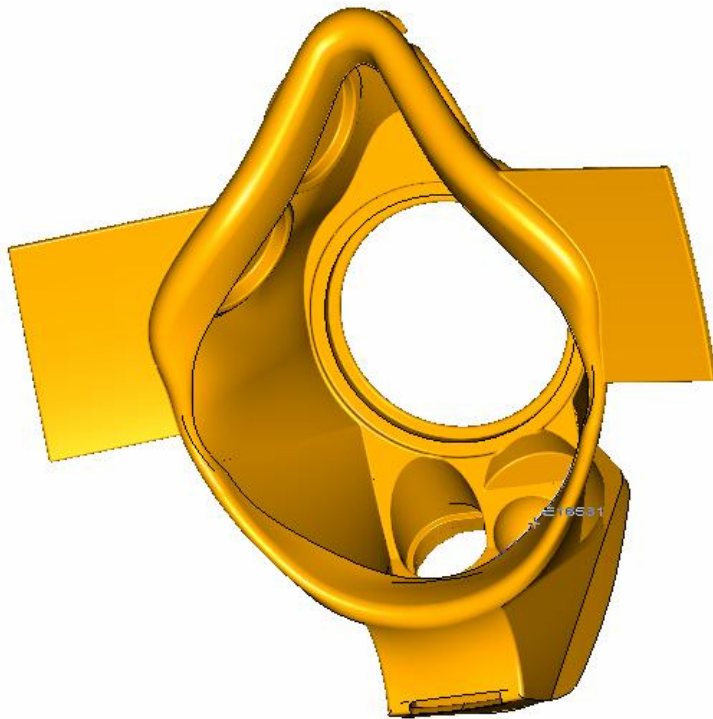

Nosecup final configuration

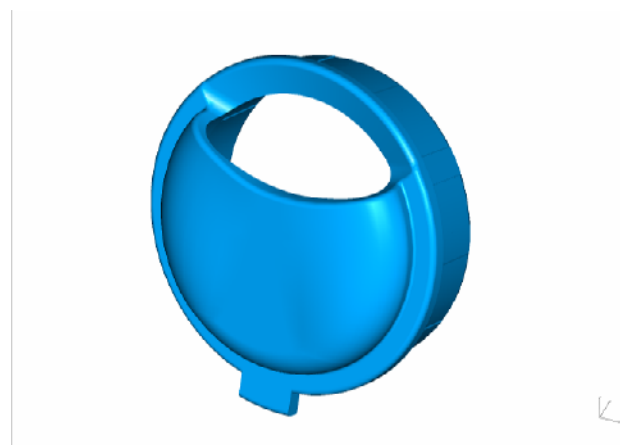
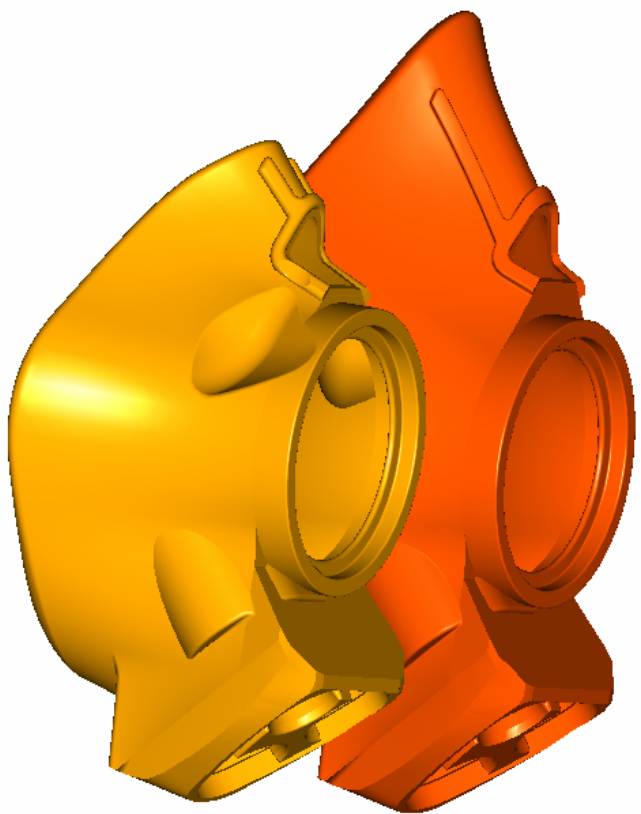

Hood Design

Hood Retention
Slot

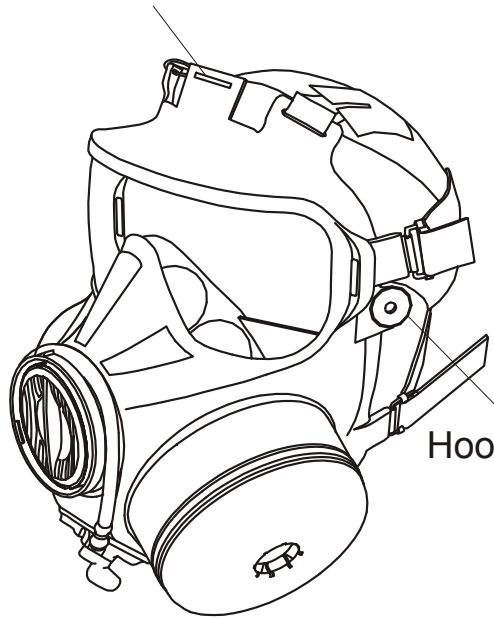

Hood Button
Tab

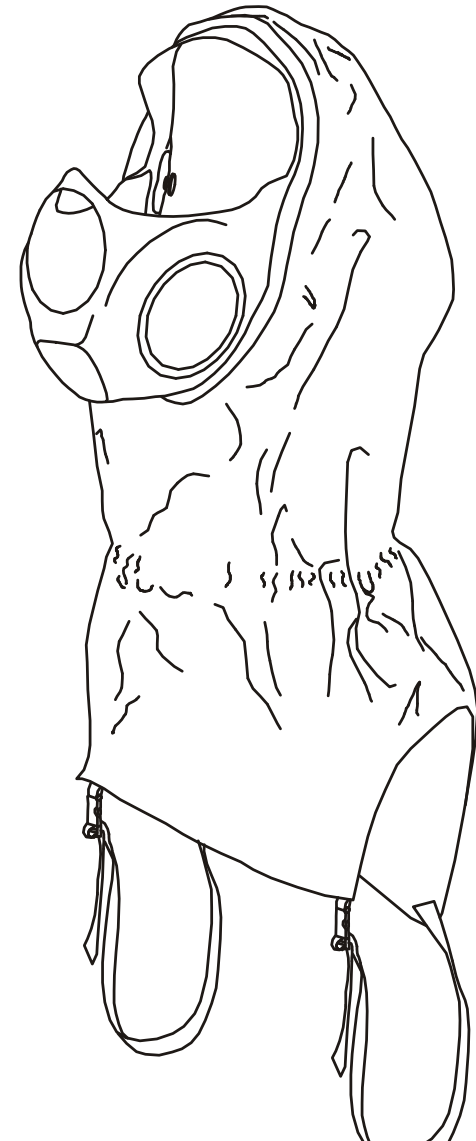



Hood Design Consideration

- 24 Hour protection
- Light weight
- Easily donned
- Detachable

Hood Design

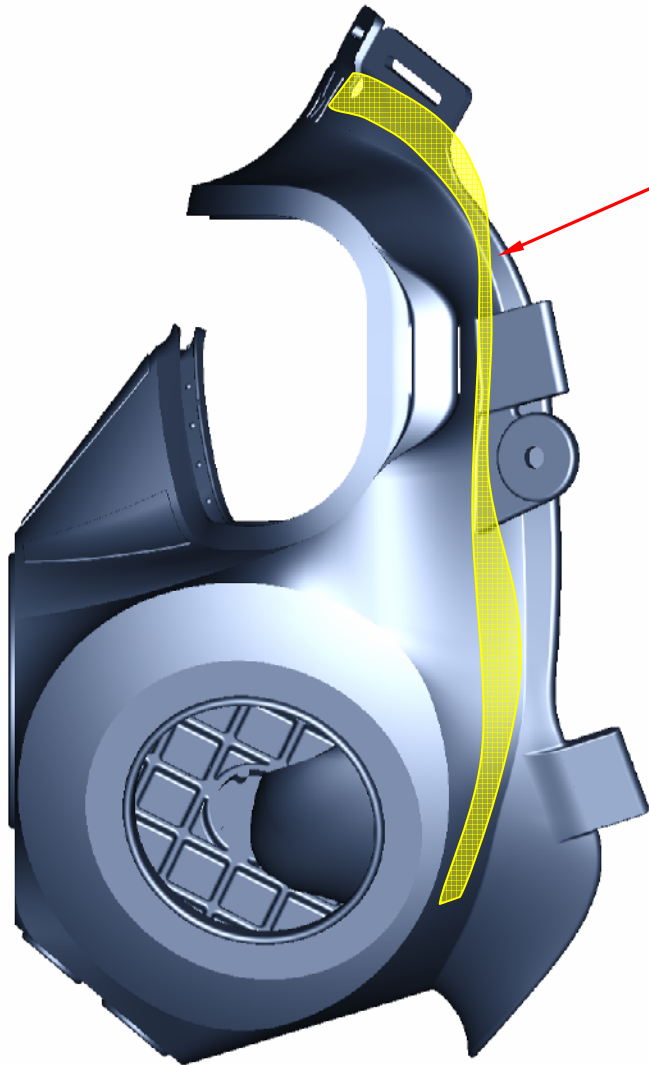

Sealing Zone

The yellow band indicates the tight contact area between second skin and mask to provide a liquid resistant seal (established by prototyping)

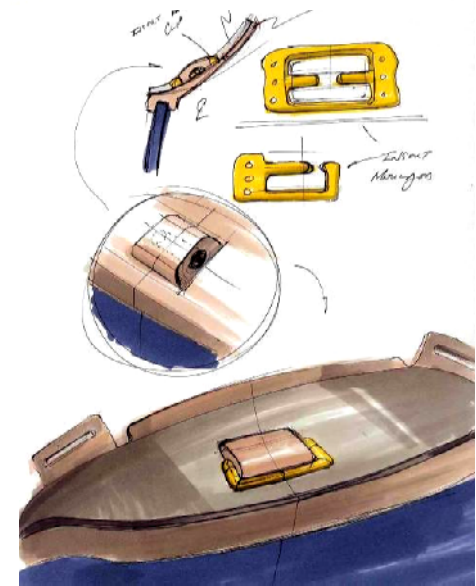
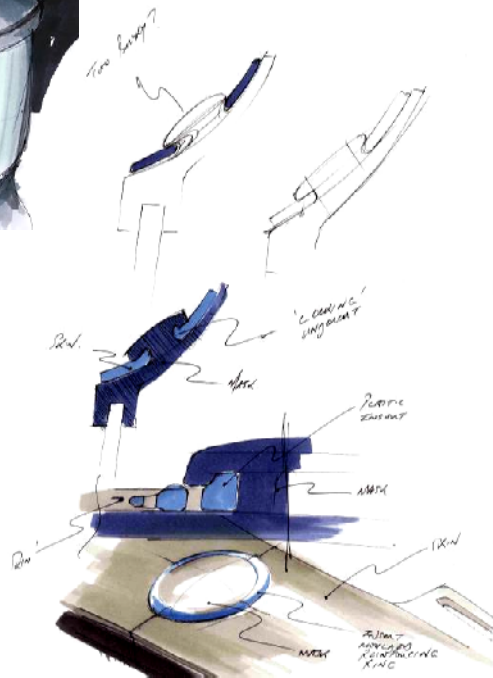
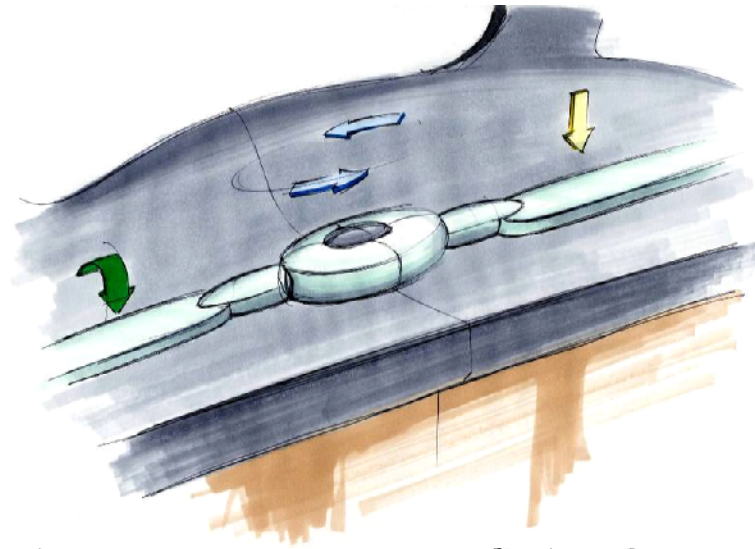

Hood Design



Hood Design

Second Skin

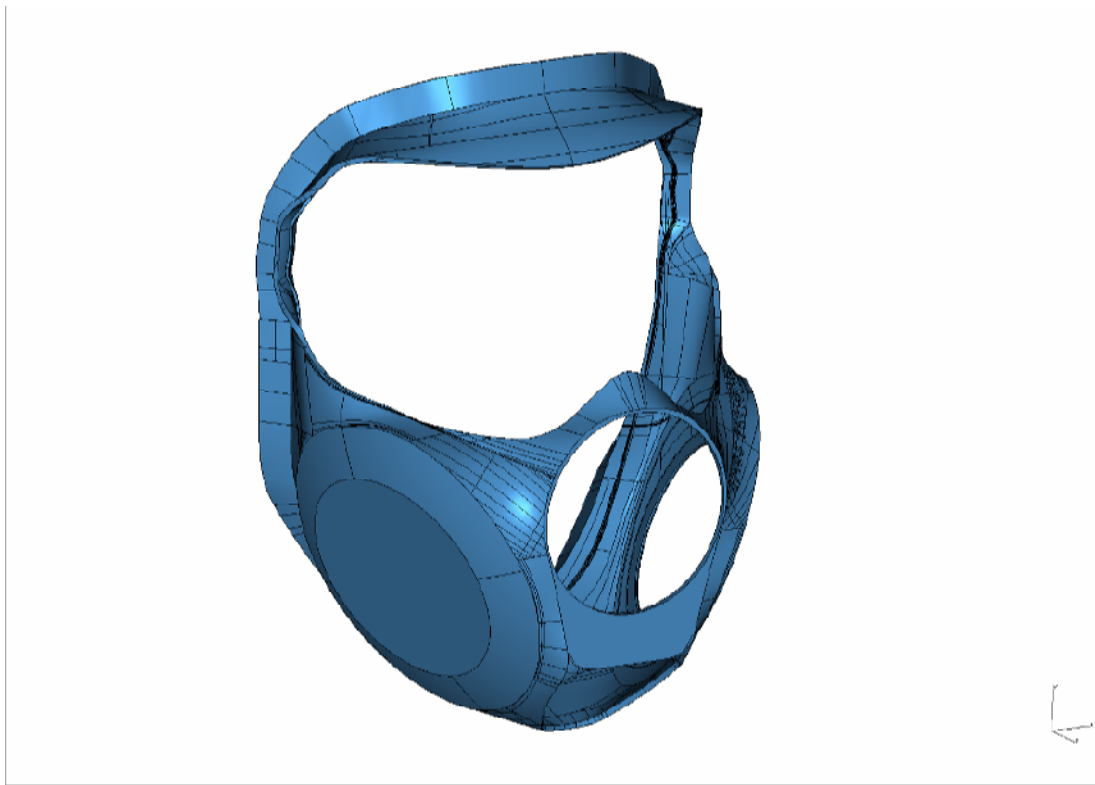

M53 Sizes

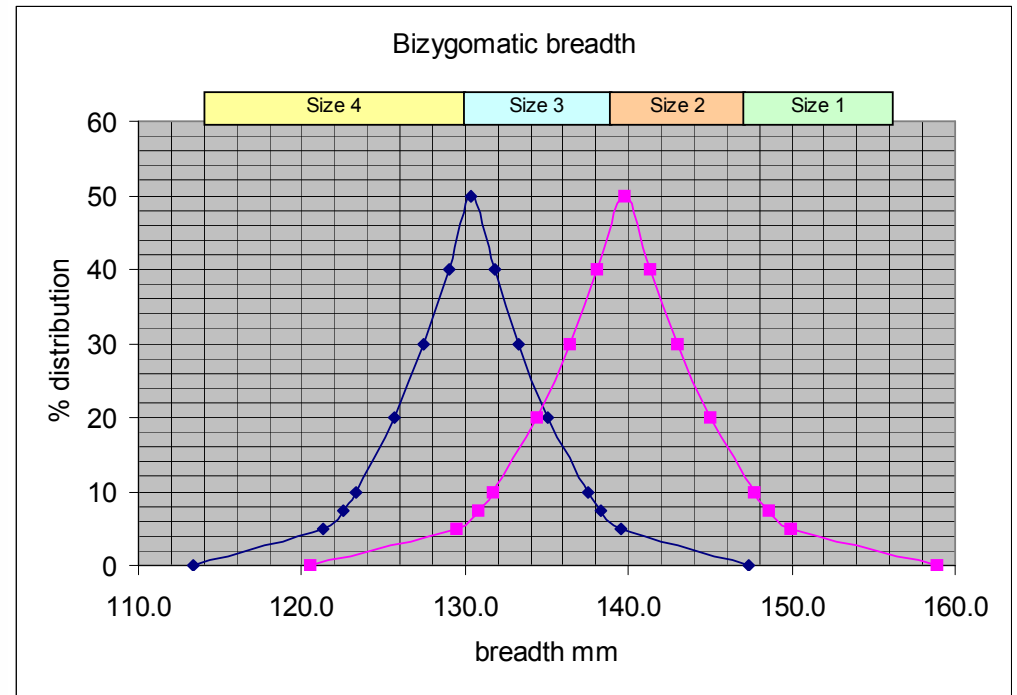
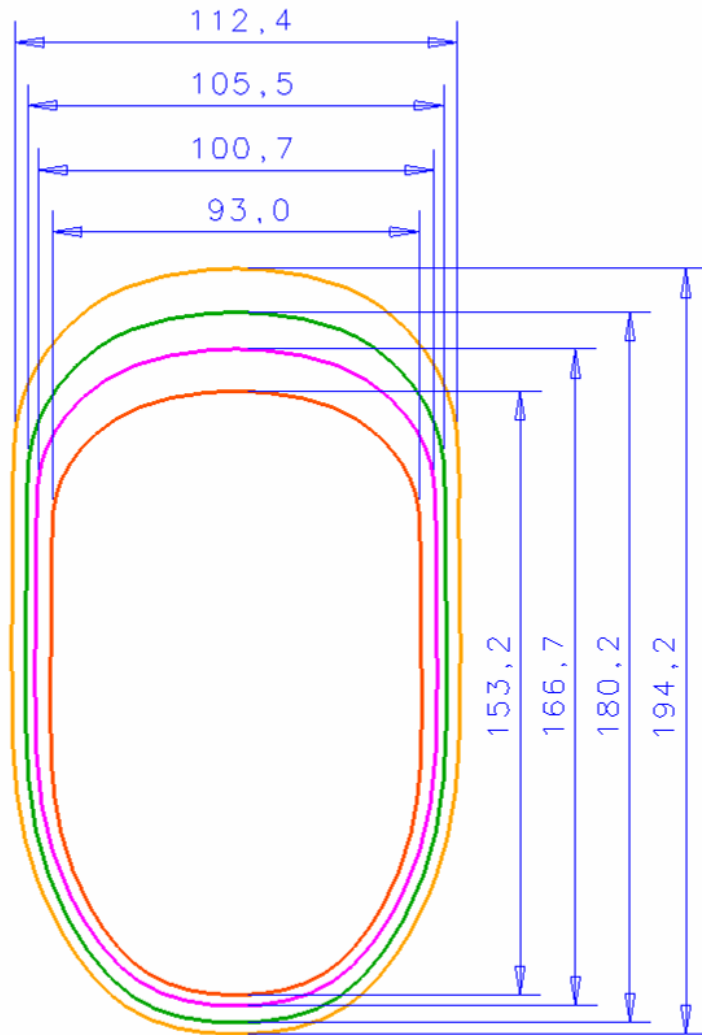

Interchangeable Nosecup

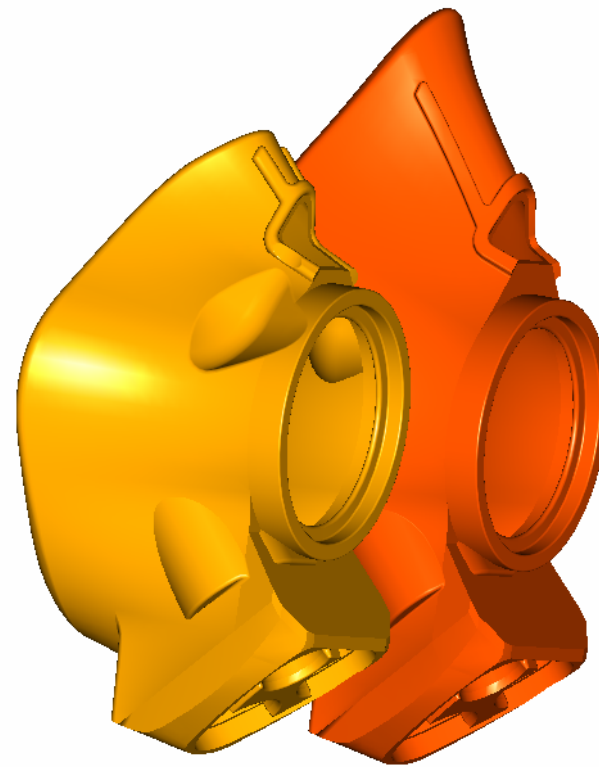
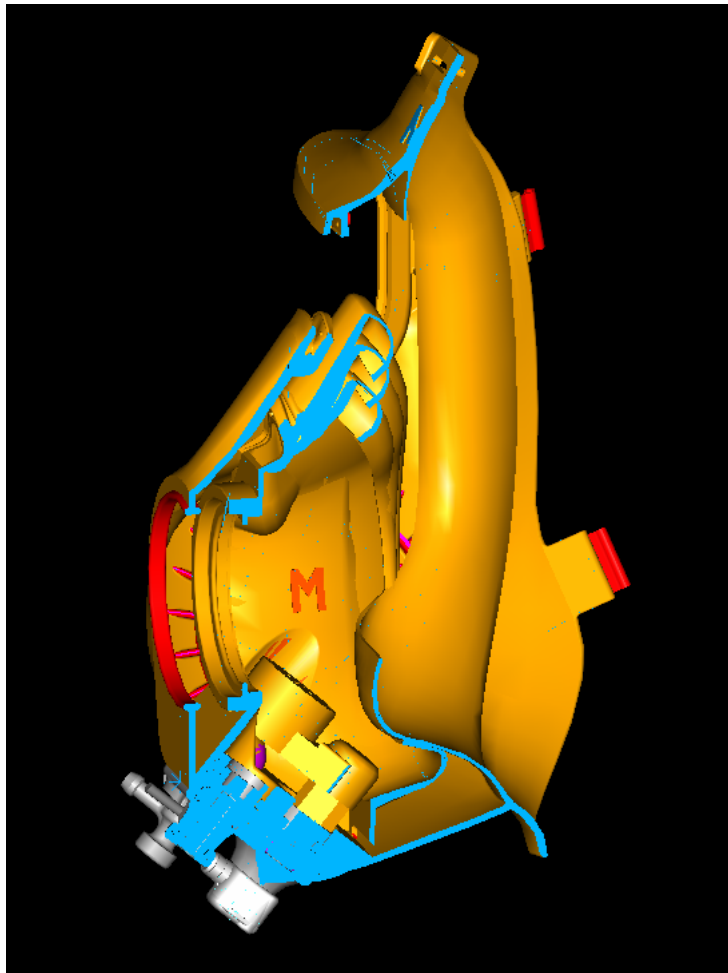



Product Qualification

- In April 2004, 400 medium size right-hand M53 masks were delivered to the DoD for evaluation.



Final Test Phase

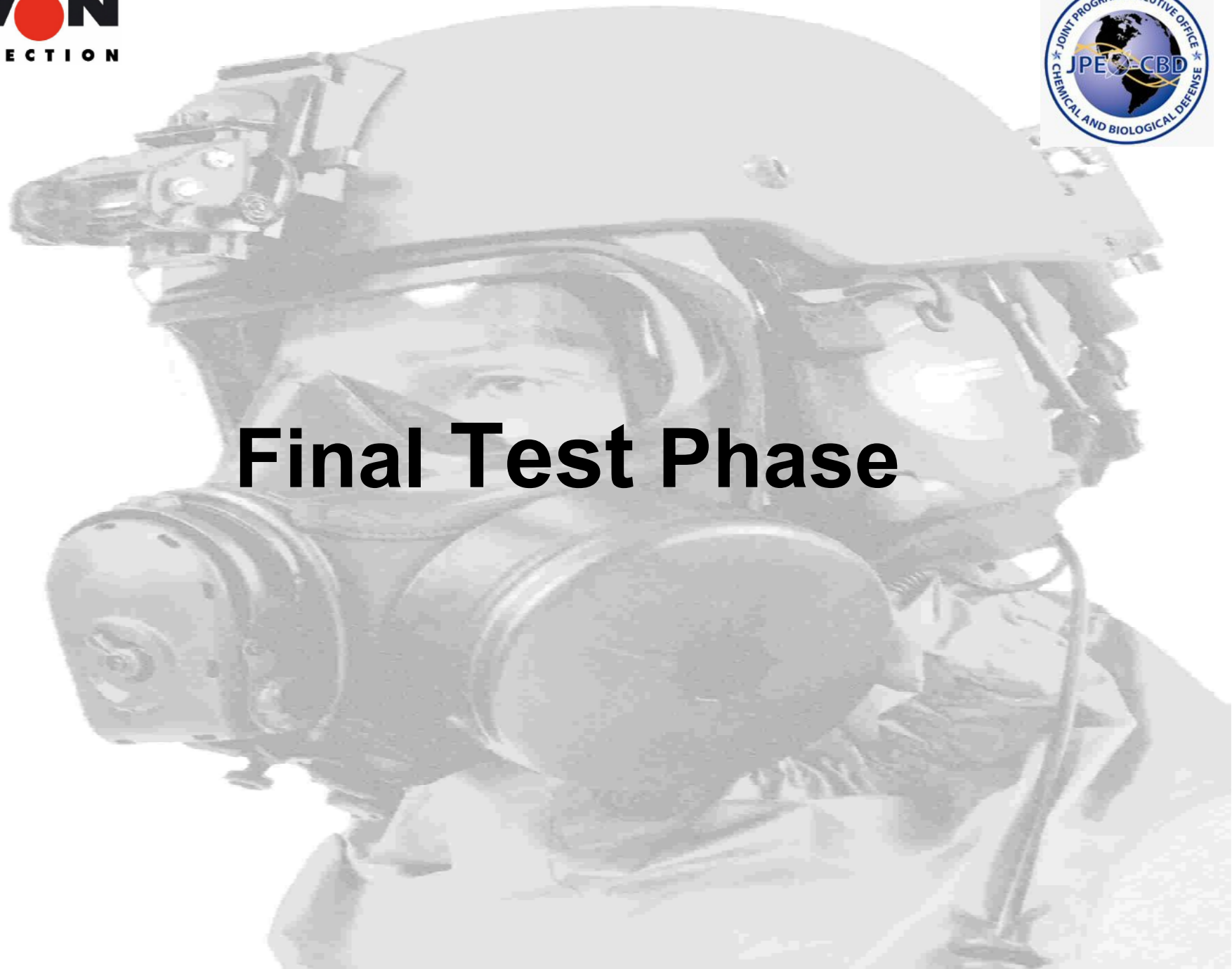



Production Qualification Testing (PQT) and Operational Test (OT)



PQT/OT PLAN for SDD Masks

- PQT deals only with Developmental Tests
- OT assesses equipment compatibility, drinking and the ability to complete mission tasks
- Data is leveraged from previous JSGPM testing of common components and features
- Labs use previously written JSGPM test plans as a guideline for writing the M53 detailed test plans

Operational Test Exercises



- Field Exercises
- Maritime Scenarios
- Weapons Systems Firing
- Medical Skills
- Vehicle Driving
- Close Quarter Battle
- SOF Mission Needs



Operational Test

- **Equipment Compatibility**
 - Radio Equipment
 - SCBA Compatibility
 - Helmet & NVG
- **Human Factors**
 - Vision and Field of View
 - Overall Comfort
 - Breathing Resistance
 - Cheek to Stock Weld



Product Approval



- Production Verification Testing
- All design and testing was completed to support the war fighters needs and program milestone
- The program was approved to enter the production phase
- M53 mask development, design and test in 2.25 years
- A True Team was formed that successfully executed the development and has remained intact to execute the mask production.

AVON
PROTECTION



Production

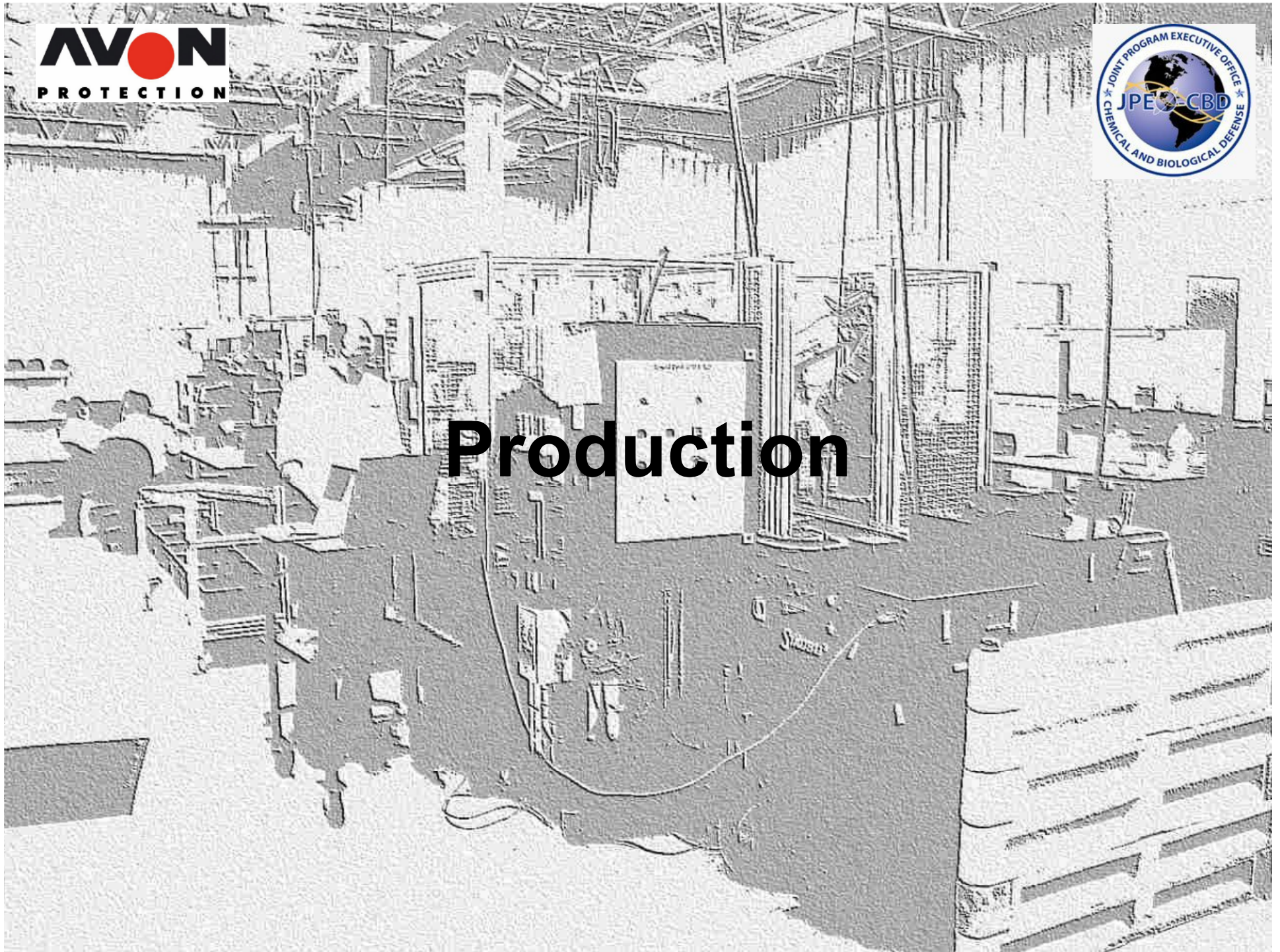



Eyelens Manufacturing

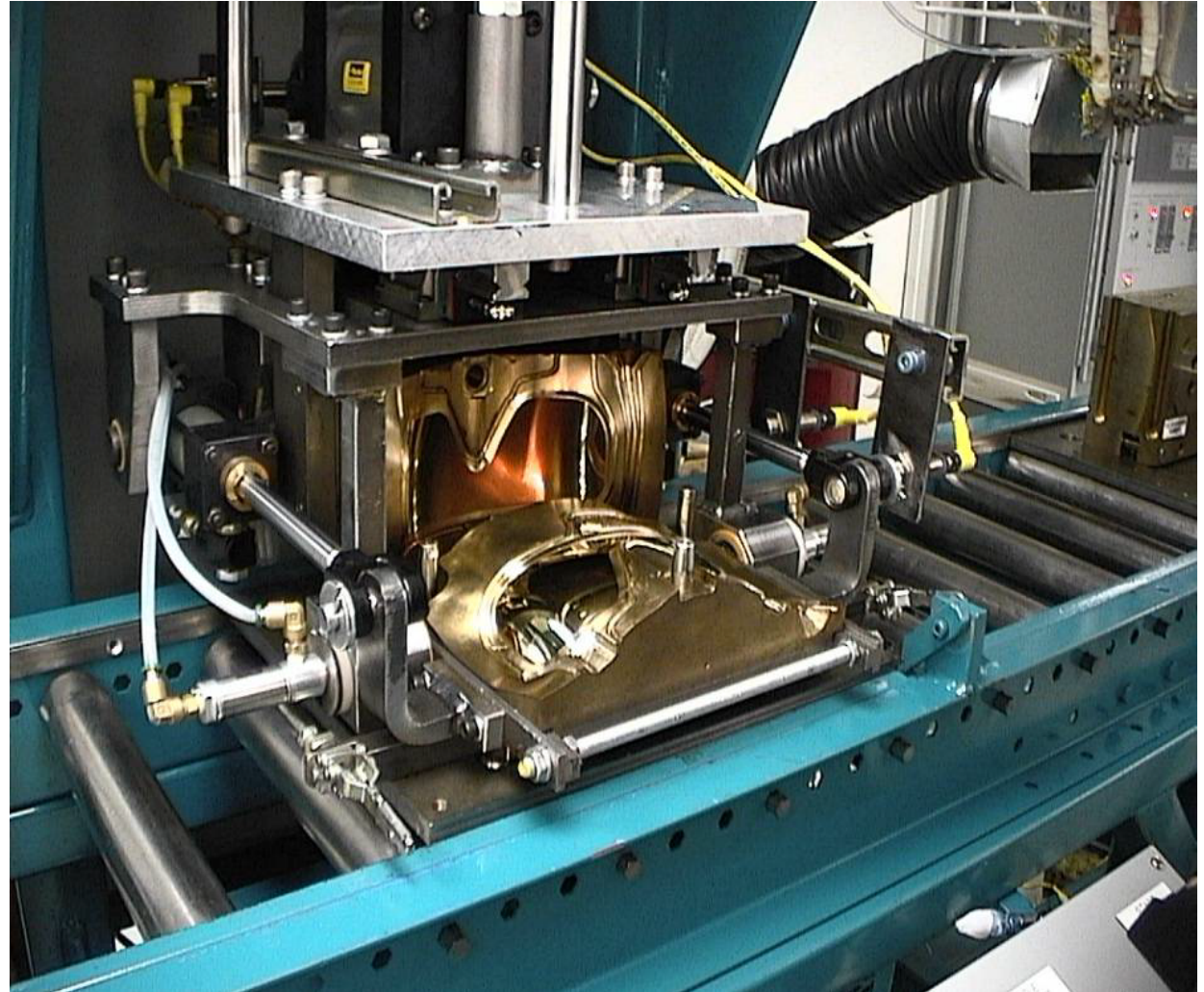

Bonding



Bonding

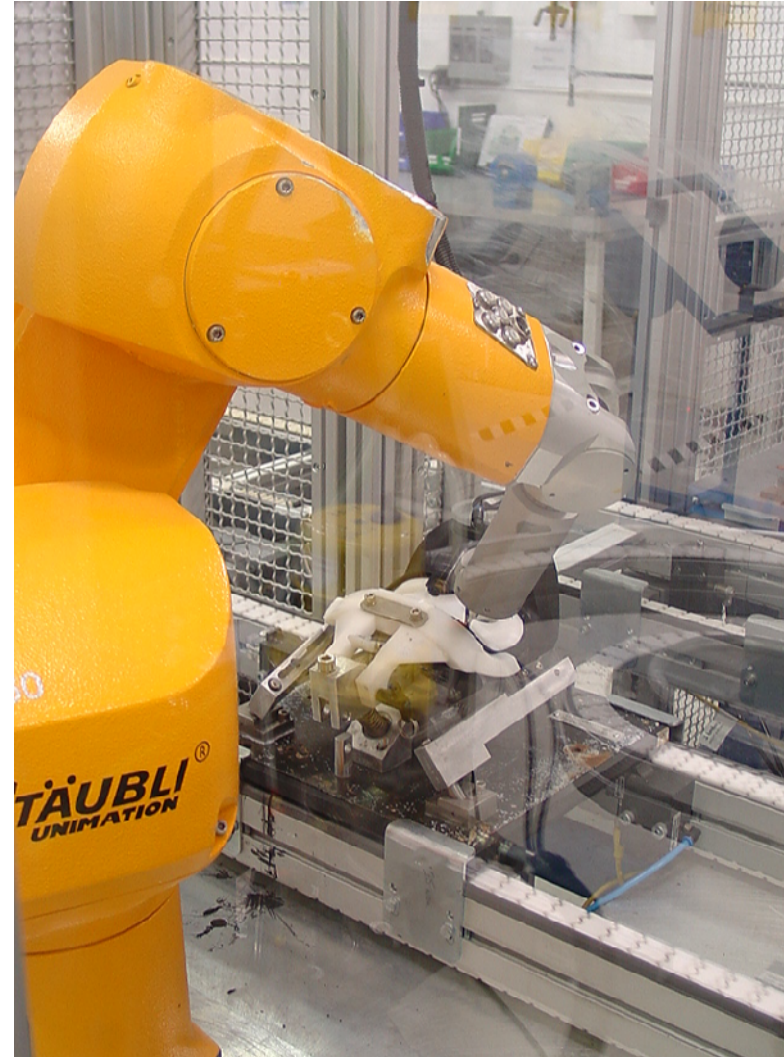
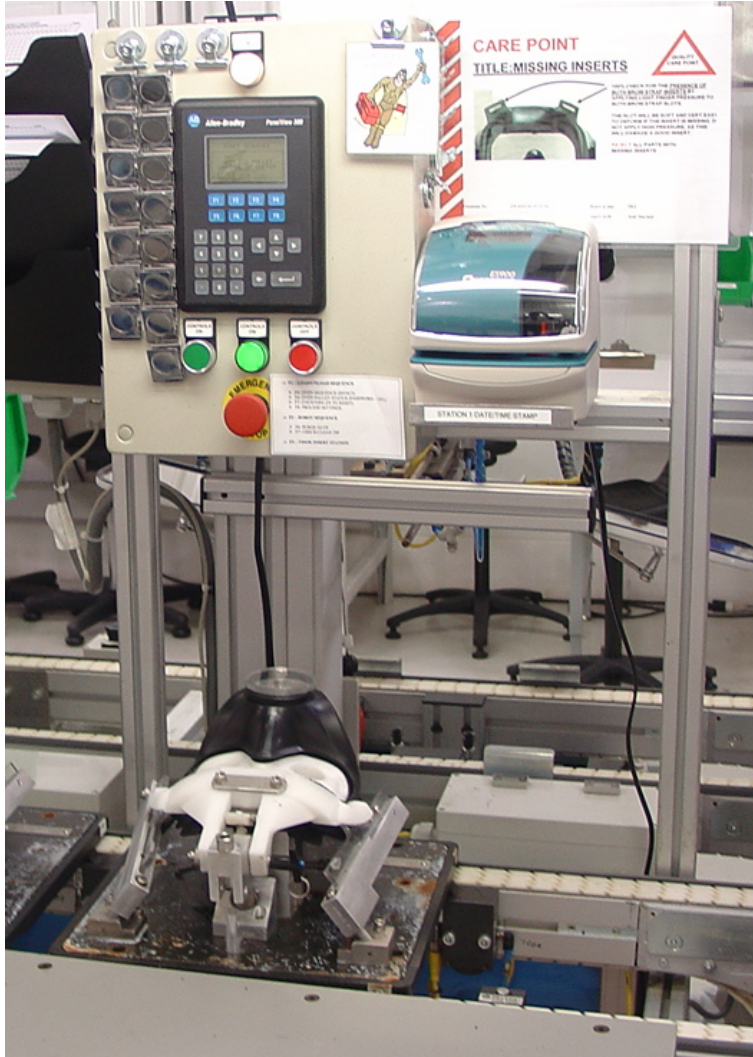

Bonding

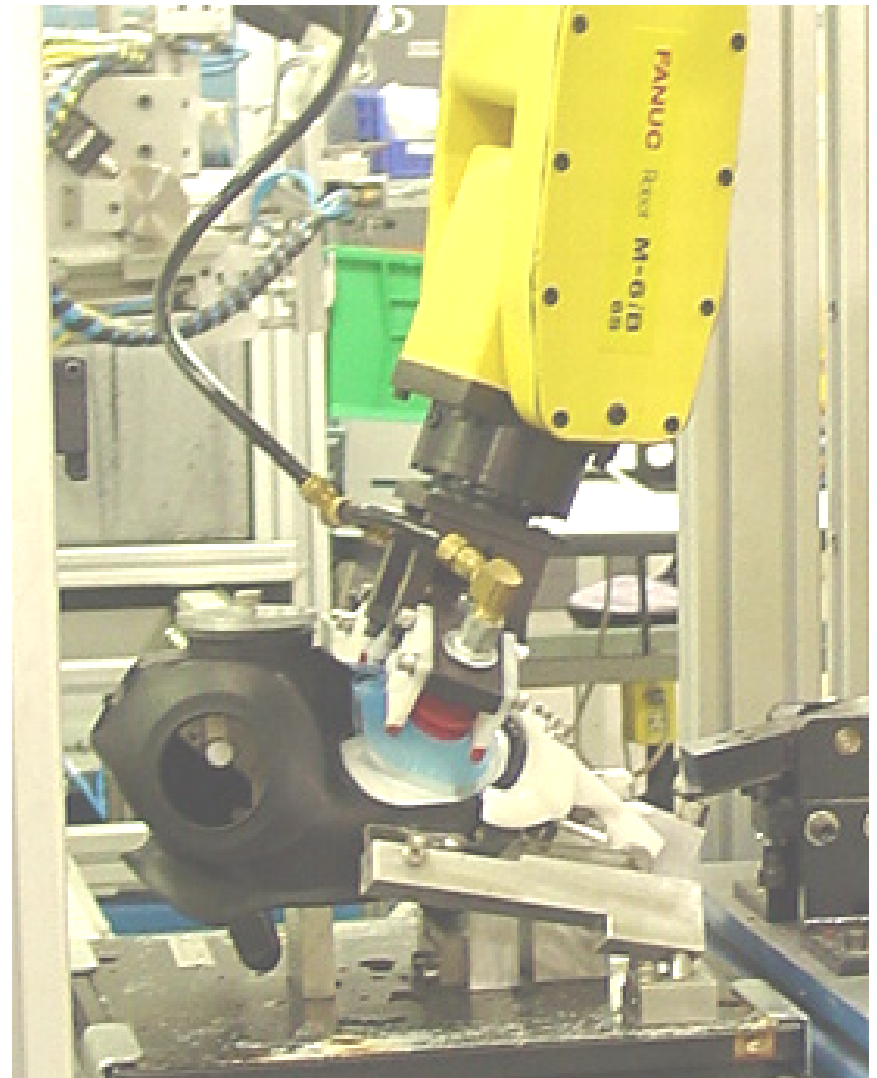
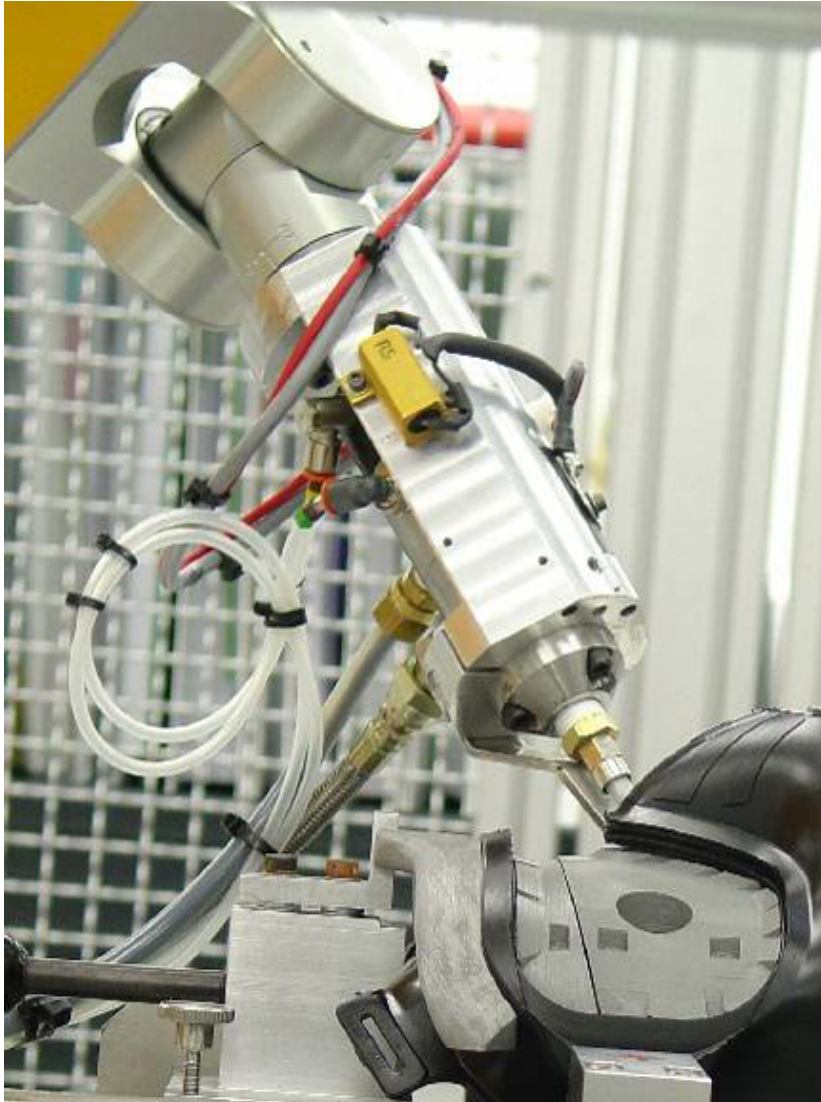

Assembly Line



Testing



Fielding Plan April 2006





Questions?