

BAE Systems V2C2 Program



Presented at:

NDIA
Gun and Missile Systems Conference &
Exhibition

Presented by:

Mr. Bruce Zierwick
BAE Systems, Land & Armaments
Minneapolis, Minnesota
March 27 - 30, 2006



The intent of this presentation is to provide an overview of BAE Systems' 105mm Variable Volume Chamber Cannon (V2C2) program and show the flexibility and unique capabilities of the V2C2 that have been demonstrated over the past year.

- **Began Internal Research & Development Program in March 2003**
- **V2C2 Program Objectives: Identify & develop an innovative technology that would reduce the development and fielding costs for a new 105mm cannon:**
 - **Provide a new 105mm cannon with enhanced performance**
 - **Position BAE Systems to offer a 105mm cannon for FCS NLOS-C should that be the cannon of choice (decision to retain the 155mm NLOS-C cannon was made in March 2004)**
 - **Reduce development costs and realize logistics benefits by using a currently fielded propellant**
 - **Provide capability to optimize integrated armament-ammunition performance**

The V2C2 system solution enables:

- **Fielding of improved 105mm artillery without development of new propellant**
- **Reductions in logistics tail and support costs**
- **Reductions in overall system weight for a given performance**

- Development Team:
 - BAE Systems: Project Lead & funding, System Design, Variable Volume Design, Seal Design, Integration, Test Projectile Fabrication
 - ARDEC: Test Projectile Design, Laser Igniter, Internal Ballistics Analysis, Structural Component Design (Benet Labs)
 - ARL: NGEN Internal Ballistic 2-D dP Analysis
 - Watervliet Arsenal: Gun Tube and Breech Fabrication
- Contractual Arrangement
 - All Work Conducted Under a Government/Contractor Cooperative Research and Development Agreement (CRADA)
 - Integrated Team Approach with Work Split Between Organizations Based Upon Areas of Expertise to Leverage Strengths

V2C2 Armament System Overview

- Variable Volume Chamber Cannon (V2C2) (Patented)
- Fully-Automated 105mm, 62-caliber Cannon
- Utilizes (M231 & M232) MACS Propellant Common to 155mm Artillery
- Fires Existing and Developmental 105mm Projectiles/Fuzes
- Extended Range (>30km assisted/24km unassisted)
- Estimated weight of Fully Automated Cannon < 2500 lb

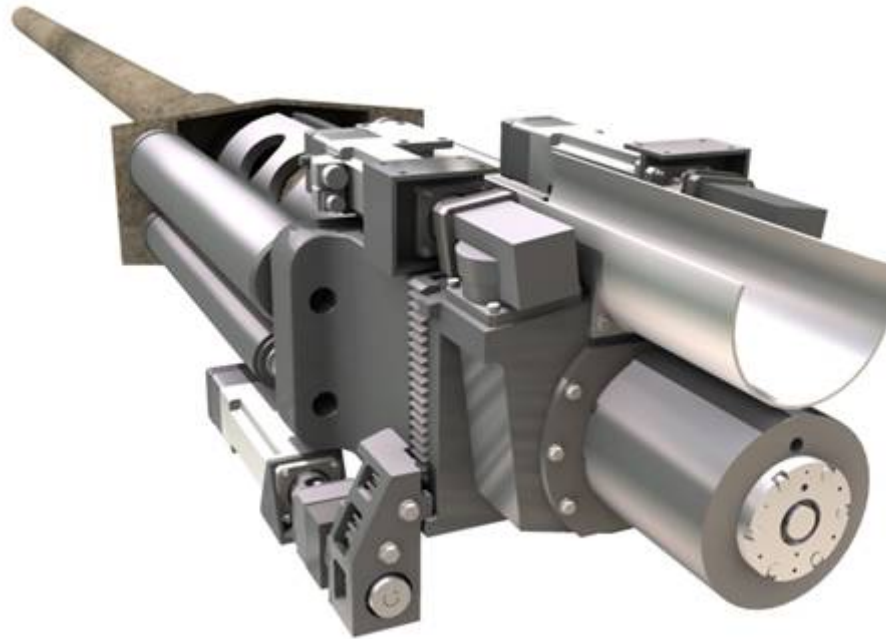

V2C2 Armament System Overview



V2C2 Breech Configuration

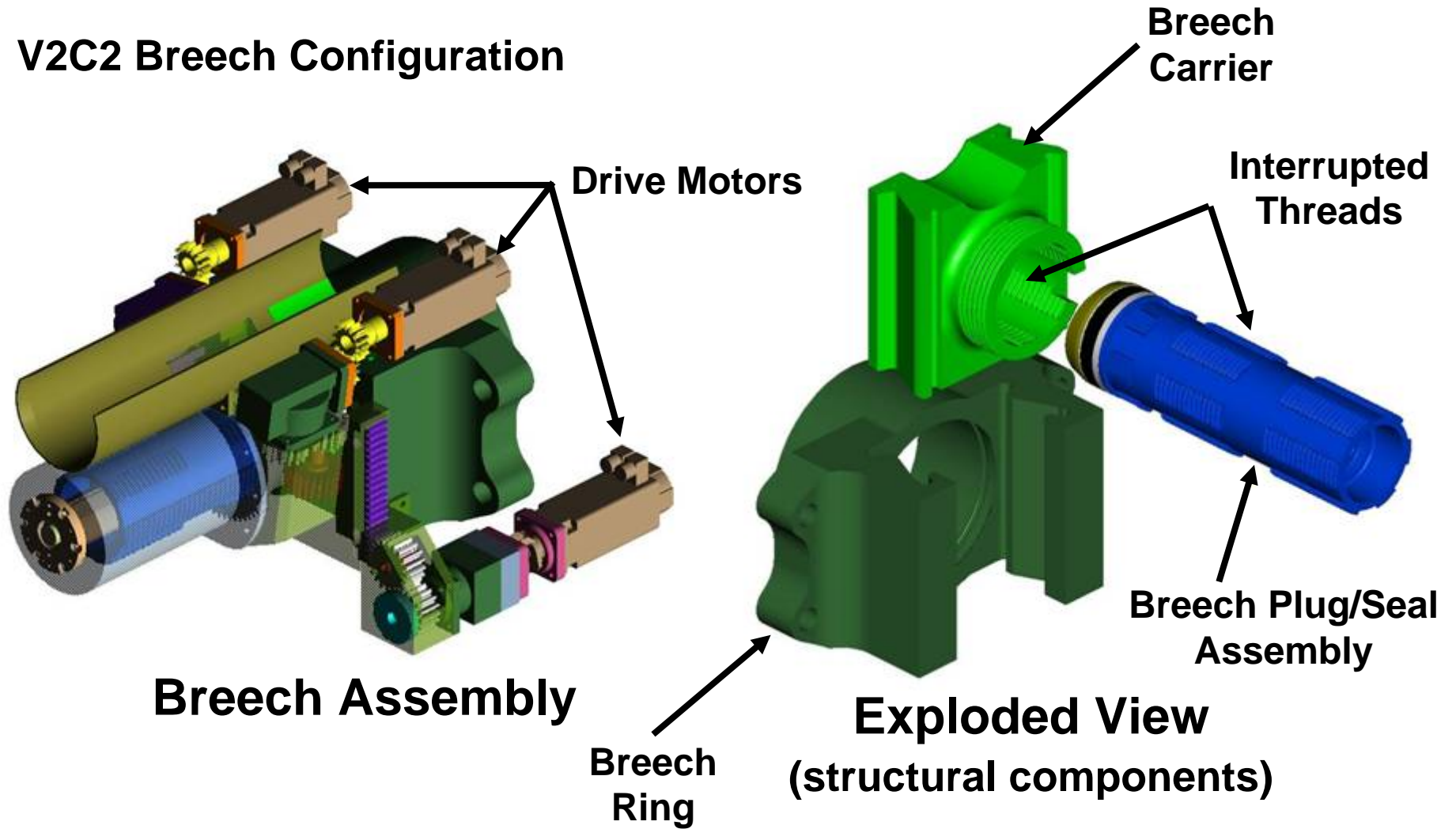

V2C2 Armament System Overview



V2C2 Breech Operation

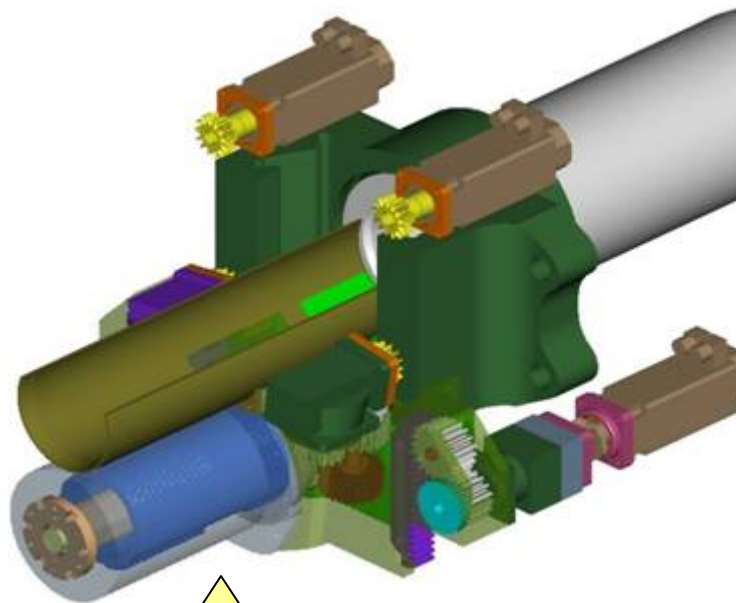

1. Raise Breech Carrier

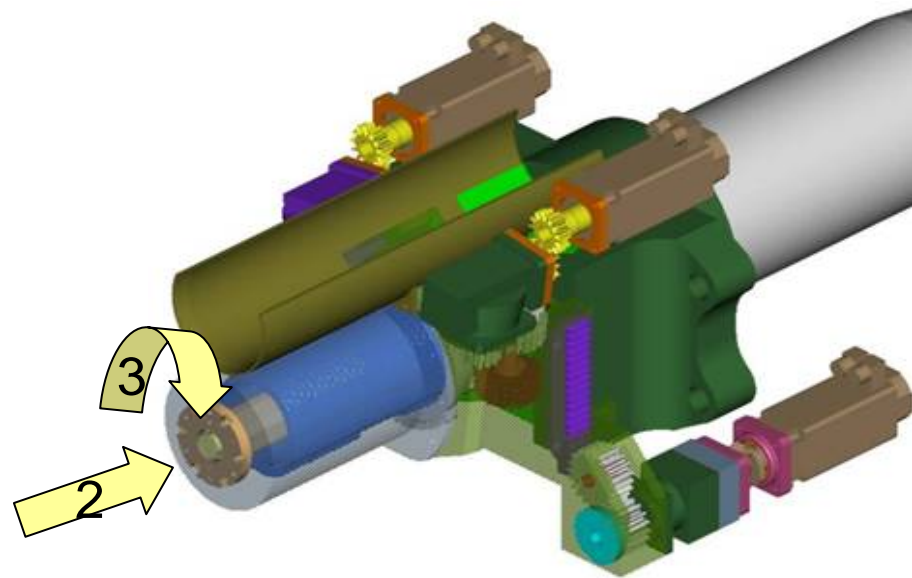

2. Translate Breech Plug Assembly into Chamber to Set Chamber Volume

3. Rotate Breech Plug to Lock

V2C2 Demonstrator System

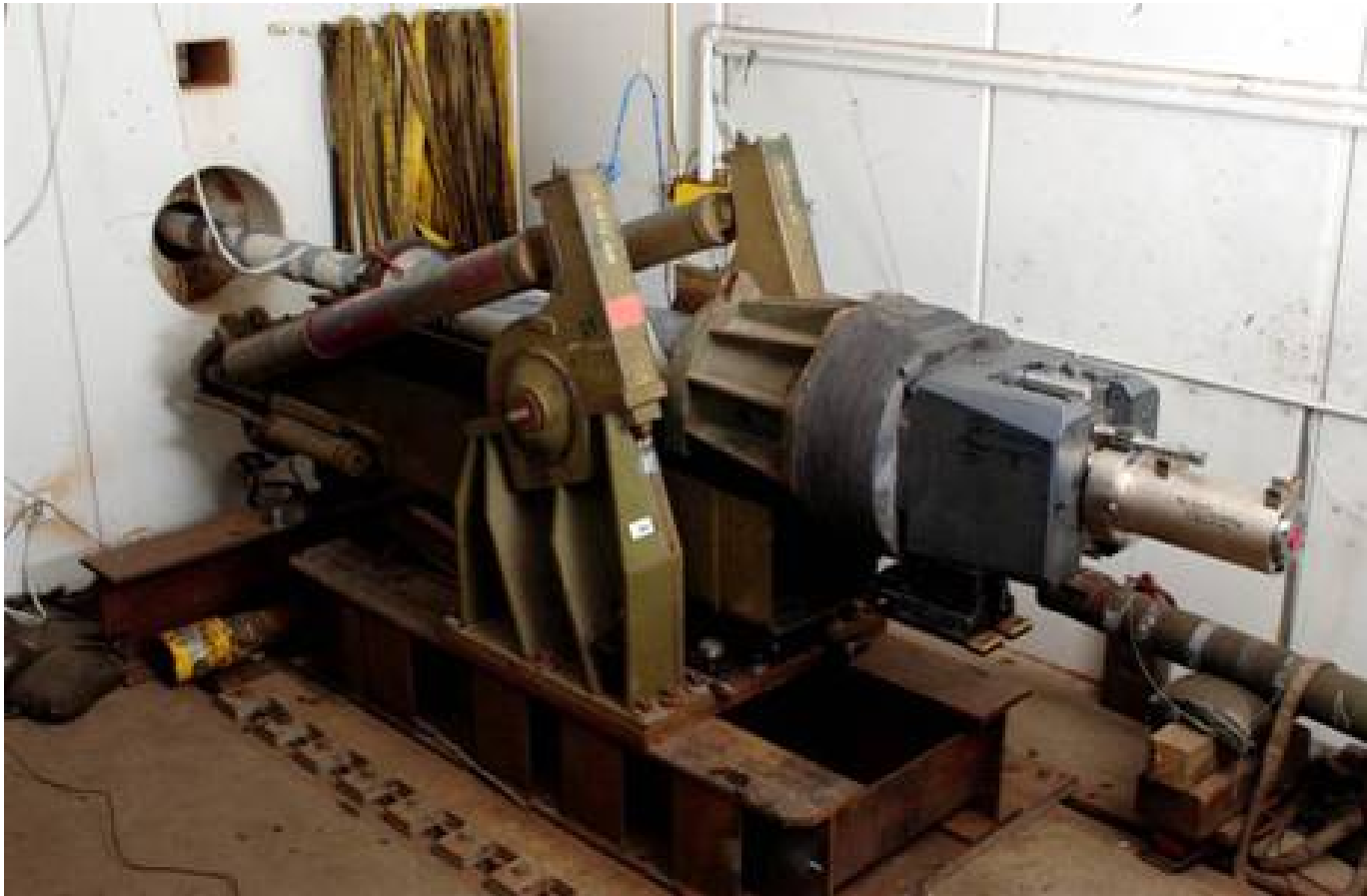

V2C2 Demonstrator Cannon Installed at Test Range

V2C2 Test & Evaluation Summary

- Demonstrator Test Program (264 shots)
 - Demonstrated acceptable internal ballistics behavior under all conditions of M231 and M232 propellant conditioning, zones, and charge placement
 - Demonstrated muzzle velocity repeatability
 - Demonstrated exceptional breech seal performance
 - Demonstrated compatibility with MACS M232A1 charge
 - Demonstrated compatibility with several current U.S. projectiles
 - Demonstrated compatibility with Denel M2019 PFF projectile
- Breech Drive Brass Board Checkout
 - Completed 20,000 cycle durability test to prove out automation
- Dual Axis Make-Break Motor Drive Brass Board
 - Developed, tested and patented a dual axis make-break connector that allows drive motors to be mounted off recoiling mass

- Conducted testing of the MACS M232A1 charge which demonstrated the ability of the V2C2 cannon to take advantage of this new charge being fielded to 155mm artillery battalions.
 - Demonstrated stable internal ballistic performance of the M232A1 charge at top four V2C2 zones
 - Collected data on the internal ballistic performance of M232A1 charge in the V2C2 cannon
 - M232A1 charge produces identical MV with slight increase in maximum chamber pressure as compared to M232 charge
 - Demonstrated ability of V2C2 to utilize and/or correct for propellant performance changes or new projectiles in order to achieve optimal systems performance





The V2C2 variable volume capability enables performance optimization by “tuning” chamber volume to achieve desired pressure and velocity

Propellant Compatibility



V2C2 Zoning Solution & Ballistics – M2019 PFF & M913* Projectiles

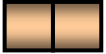
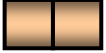

Zone	Charge Solution	Chamber Volume (in ³)	Peak Breech Pressure (psi)	Muzzle Velocity M2019/M913* (m/s)	Max Range M2019/M913* (km)
6	3 – M232A1 	700	54,089	996 / 1020	30.7 / 31.7
5	3 – M232A1 	800	47,063	958 / 981	29.0 / 30.5
4	2 – M232A1 	500	36,660	824 / 844	23.8 / 26.2
3	2 – M232A1 	800	23,032	744 / 762	21.2 / 23.5
2	1 – M231 	500	24,931	537 / 550	15.0 / 16.8
1	1 – M231 	800	15,540	484 / 496	13.5 / 15.2

* Tested using surrogate projectile with iron rotating band

Results support use of fielded and developmental 105mm Projectiles to extended ranges with acceptable range overlap

U.S. Projectile Compatibility Predictions (ARDEC)

- **Projectile compatibility of current 105 inventory was based on surrogate projectile test data and ARDEC models:**
 - **Evaluated projectile interface to V2C2 Chamber**
 - **Determined current pressure, MV, acceleration, and spin limitations of eleven (11) inventoried 105MM rounds**
 - **Assessed limitations based on firing tables, aeroballistics GTRAJ code, Interface Control Documents, projectile drawings, historical rotating band analyses and structural engineering assessments**
 - **Compared current limitations against V2C2 zoning data for 155 MACS**
 - **Calculated current M913 projectile slug Pressure Ratio and compared to actual firing data using the surrogate projectile**
 - **Pressure ratio was utilized to attune calculation of predicted accelerations for each of the eleven rounds**
 - **Inspected recovered projectile hardware from V2C2 Firing (Projectile Slugs with Iron Rotating Band and AMODEL Obturator)**
 - **Analyzed Rotating Band Wear measurements**
 - **Generated V2C2 Projectile-Zone Compatibility Chart based on all information available to date**

Projectile structural compatibility is based on current use limits while rotating band assessments are based on test data and wear models

U.S. Projectile Compatibility Predictions (ARDEC)



Projectile	Current Max Range	Current MV Limits	Zone 1	Zone 2	Zone 3	Zone 4	Zone 5
M1 HE	11.5 Km	502.4 M/S	R	V, R	Tested	V, R, Sp, S	V, R, Sp, S
M60 Smoke	11.5 Km	491.4 M/S	R	V, R	Similar to	V, R, Sp, S	V, R, Sp, S
M84A1 smoke	11.5 Km	503 M/S	R	V, R	Tested	V, R, Sp, S	V, R, Sp, S
M314A3 Illum	11.5 Km	492.4 M/S	R	V, R	Similar to	V, R, Sp, S	V, R, Sp, S
M444 ICM	11.5 Km	497 M/S	R	V, R	Similar to	V, R, Sp, S	V, R, Sp, S
M548 HE RA	15 Km	563 M/S			V, Sp	V, Sp, R	V, Sp, R, S
M760 HE	14 Km	658.3 M/S			V, R	V, R, Sp	V, R, Sp, S
M913 HE RA	19 Km	673.3 M/S			Surrogate Testing	V, R, Sp	V, R, Sp, S
M915 DPICM	14 Km	637.3 M/S			Plan to test in 2006	V, R, Sp	V, R, Sp, S
M916 DPICM	14 Km	488.4 M/S		V, R	Similar to	V, R, Sp	V, R, Sp, S
M927 HERA	15 Km	496.6 M/S	R	V, R	Similar to	V, R, Sp, S	V, R, Sp, S

Current Projectile Limits Exceeded (R = rotating band, V = velocity, Sp = spin, S = structural)



= Rounds can be fired



= Rounds Marginal



= Not Recommended

- **Special surrogate test slug:**
 - Test slug was designed by ARDEC to simulate the physical characteristics of the M913 with a welded iron rotating band
 - Performed successfully at all zones up to zone 6 (1010 m/s) which would propel the M913 with modified rotating band to 31.7 km range
 - Given the base pressures, rotating band performance, and projectile design integrity, the results indicate a strong potential for the M913 with an iron rotating band to be utilized at zone 6
- **Limited testing of 2 U.S projectiles to date**
 - M1 HE projectile: performed well at zone 3 (750 m/s, 16.5 km)
 - M84 Smoke projectile: performed well at zone 3 (750 m/s, 16.5 km)
 - All projectiles were fired with snap-on obturators
 - Only necessary when used beyond current performance levels
 - Given the similarity in design of the M1 and M84 to the M60, M314, M444 there is a high probability that these projectiles can be utilized to zone 3
 - Similarities of the M916 and M927 to the M913 may allow both of these projectiles to be utilized at zone 3, but material differences make them unlikely to function beyond zone 3

Projectile Performance Summary

Projectile Type	Predicted V2C2 Maximum Range Capability	Current known capability with existing guns
M913 HERA based on Surrogate Test Slug	31.7 km @ zone 6 30.5 km @ zone 5	19.0 km
M1 HE as tested	16.5 km @ zone 3	11.5 km
M84 as tested	16.5 km @ zone 3	11.5 km
M2019 PFF	30.7 km @ zone 6	30.0 km

The V2C2 cannon with MACS propellant allows standard projectiles with snap-on obturators to achieve greater ranges than currently possible with existing 105mm cannons

BAE Systems 105mm Variable Volume Chamber (V2C2) Long Range, Light Weight Cannon demonstrates that 105mm artillery cannons can effectively use the same propellant system as their bigger brother the “155”

- **Eliminates the time and expense of developing and type classifying a new propellant system in order to field a long range 105mm capability**
 - **Variable volume technology provides unparalleled flexibility in changing parts of the weapon/charge/propellant equation**
 - **Offers potential for reduced logistics burdens given that “one propellant system fits all”**
-