



7.62mm, Lethal Limited Range Round (L²R²) (US Coast Guard)

NDIA 2006

Prepared by:

Chad Sensenig

**Small Caliber Ammunition US Army,
ARDEC**

Sung Chung

Aeroballistics US Army, ARDEC





Objectives:

Design, develop, and demonstrate a 7.62mm Lethal Limited Range Round (L²R²) to meet the unique needs and requirements of the US Coast Guard for use in harbor security applications. This ammunition will be fired from mounted 7.62mm, M240 Machine Guns or M14 rifles and will be capable of engaging and defeating a variety of seagoing vessels and personnel targets while reducing maximum range to minimize collateral damage to the areas surrounding the locations where the round will be employed.

Goals:

- **Must function the M14 rifle and M240B machine gun with no weapon adapters / modifications.**
- **Defeat 1/4 inch of mild steel set at 30-degree obliquity angle at 200 meters.**
- **Effective against soft targets out to a range of at least 400 meter.**
- **Maximum range of 2000 Meters (1500 Meters desirable)**





Previous In-house Limited Range Effort

Caliber .50 and 5.56mm Limited Range Training Ammunition (LRTA) Programs

Caliber .50 LRTA

Requirements:

- Match M33 to 1000 meters not more than 1 mil error.
- Range not to exceed 2500 meters.
- Price not to exceed M33 cartridge.

Tested Designs:

4 designs were tested in Ft. Dix Small Caliber Test Range

- Non-conical boat tail design.
- Corkscrew boat tail design.
- Straight fin design.
- Canted fin design.





Caliber .50 LRTA Test Results (Cd Vs Mach Numbers)



50 CAL LRTA
NON-CONICAL BOATTAIL

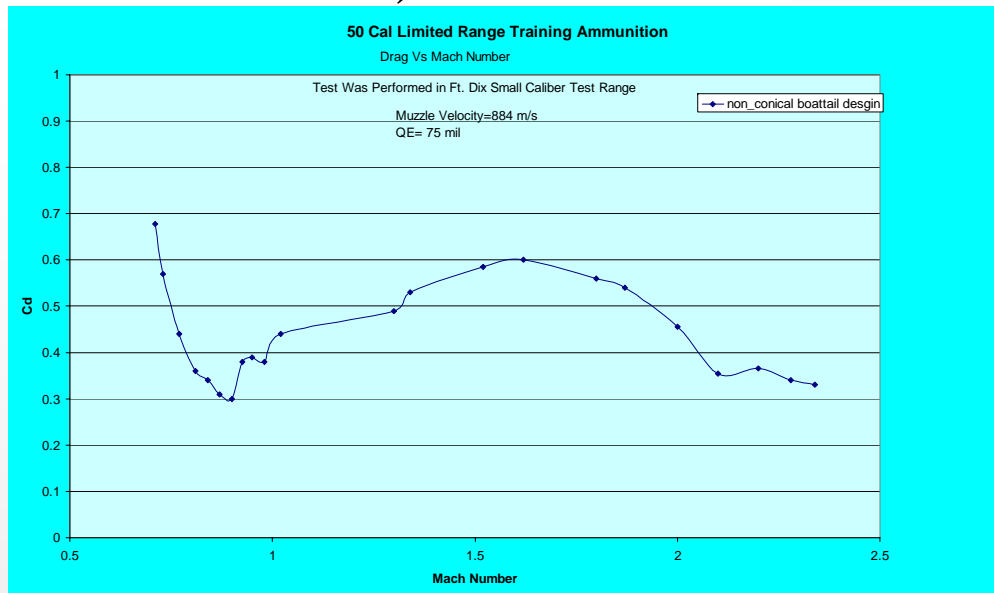
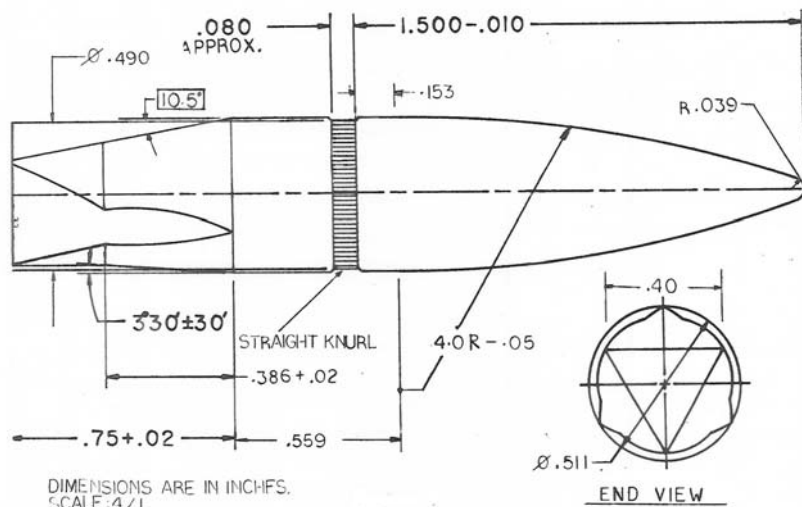

50 CAL LRTA
CORKSCREW BOATTAIL I

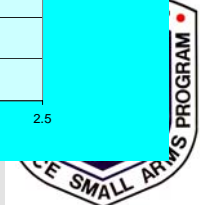
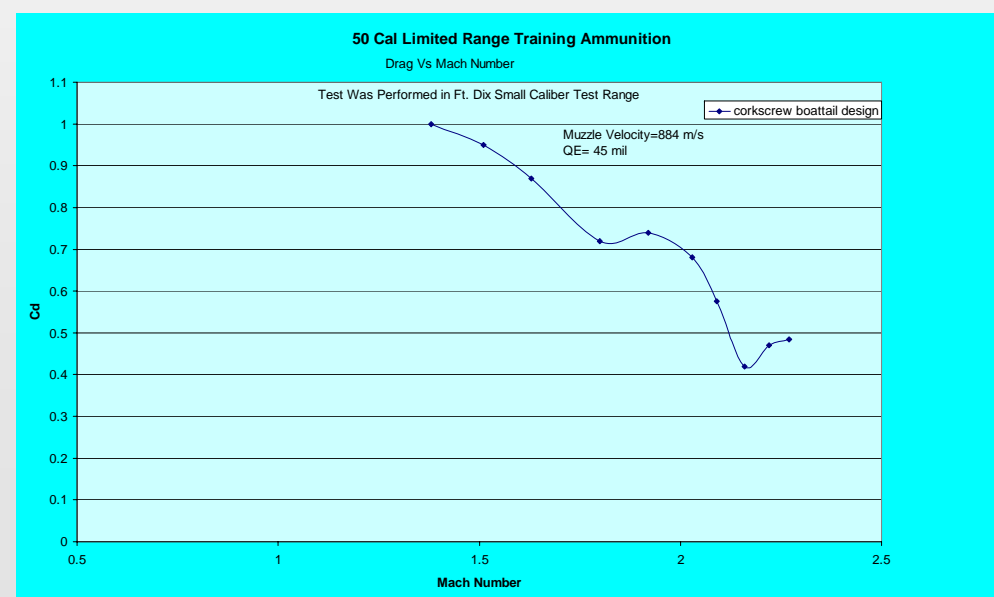
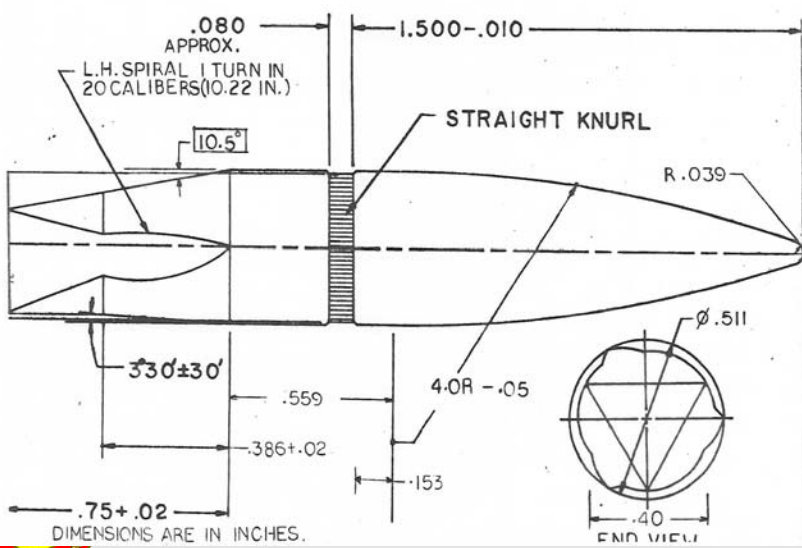



Caliber .50 LRTA Test Results (Cd Vs Mach Numbers)



50 CAL LRTA
STRAIGHT FIN

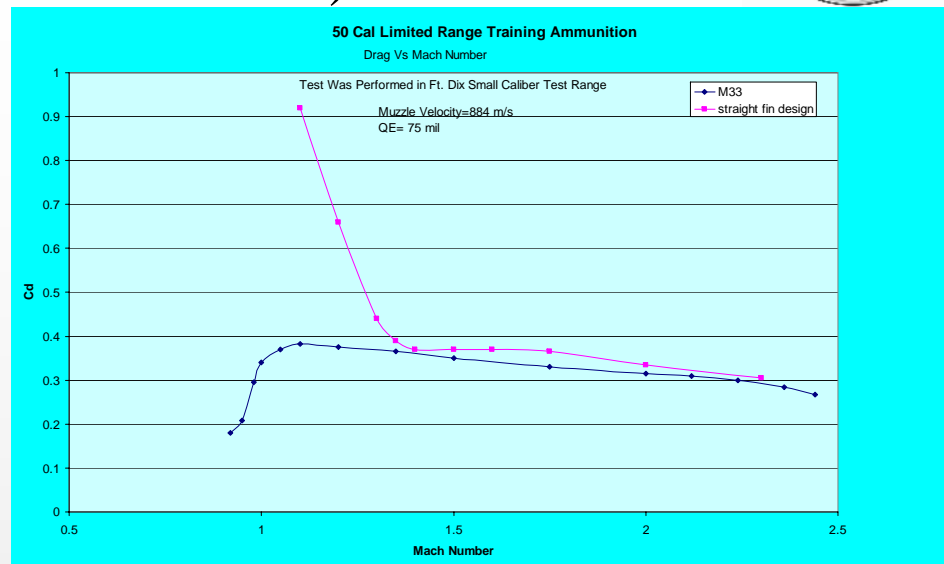
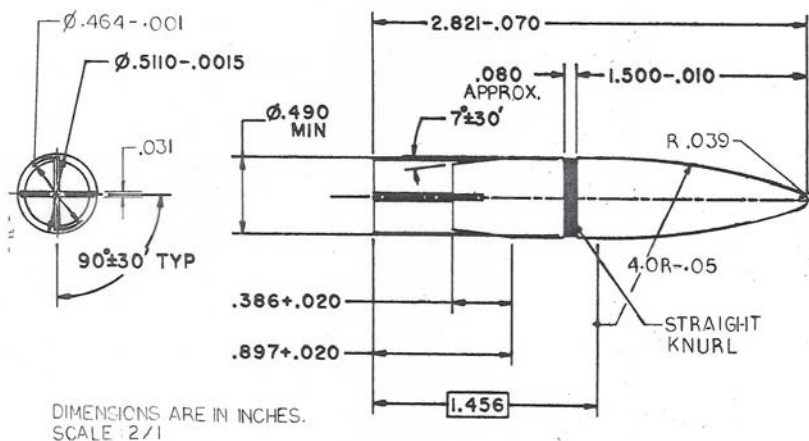

50 CAL LRTA
TAPERED FIN I

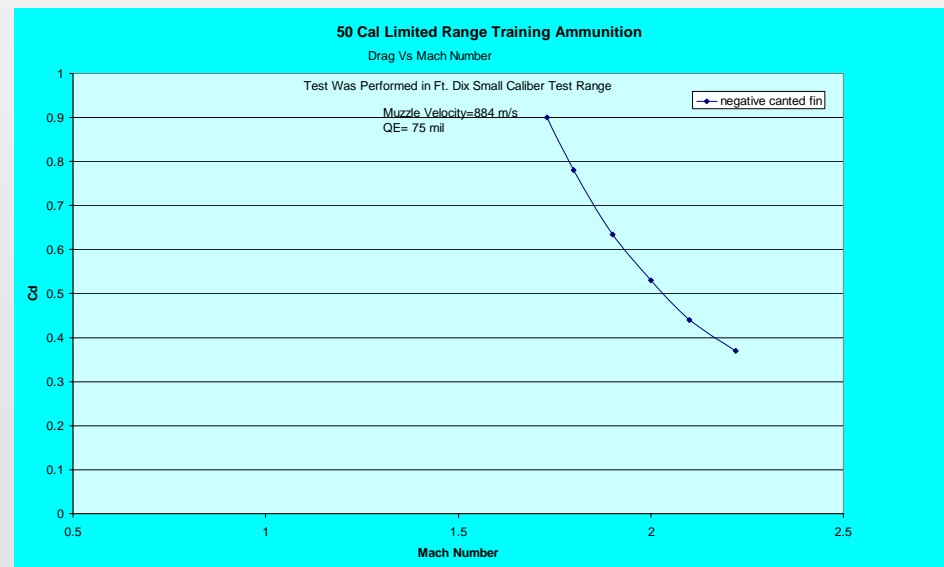
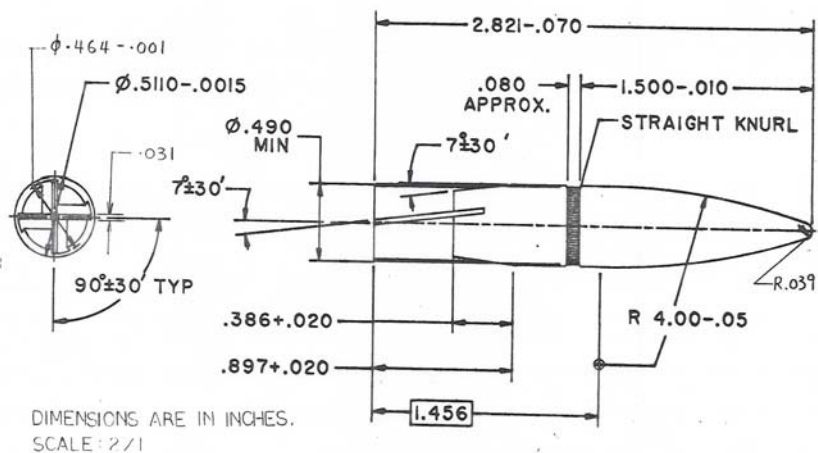

Continue

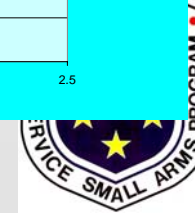



Design Approach on 7.62mm L²R²

- 7.62mm M80 external shape with the base straight fin is chosen for the design study.
- The base fin is designed to have sufficient fin area to create instability after meeting the effective range requirement. It will also increase the drag while unstable.
- Projectile mass properties are designed to minimize the max range and optimized launch stability while fulfilling the penetration requirement.





7.62mm L²R² Projectile Design Study Results

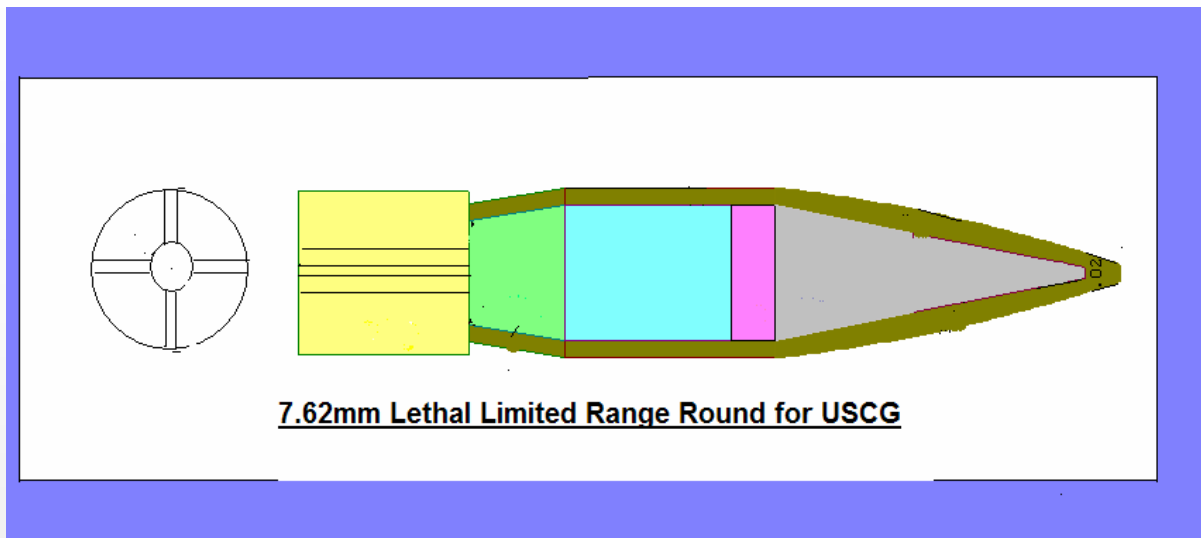

Case	Weight grain/lb	Max QE Range m	M. Vel ft/s
1	159 / .0227	2200	2508
2	125 / 0.0179	1750	2508
3	135 / 0.0193	1888	2508
4	149 / 0.0210	2105	2508
5	162 / 0.0231	2362	2508
6	146 / 0.0208	2012	2508

Projectile	QE deg	M. Vel ft/s	Weight grain/lb	I _x lb-in ²	I _y lb-in ²	C.G.nose	Range m
M80	35	2850	147 / 0.021	0.0002	0.00138	0.6886	3705
M80	35	2508	147 / 0.021	0.0002	0.00138	0.6886	3548





7.62mm L²R² USCG 6-Dof Trajectory Simulation

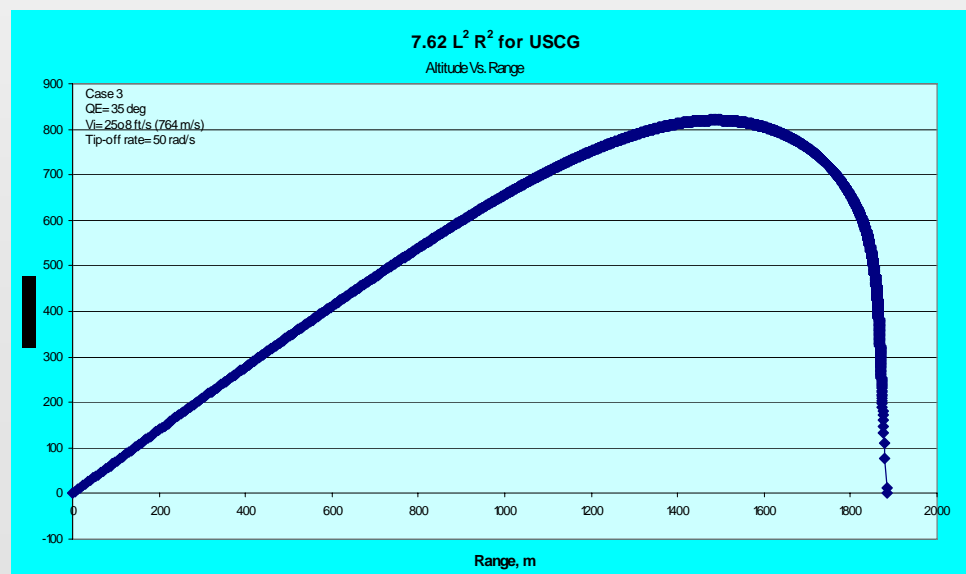
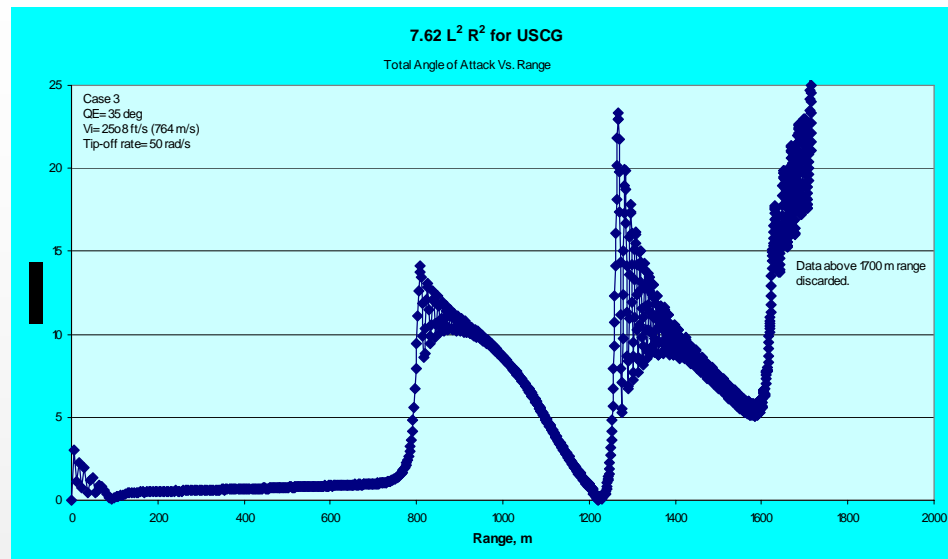
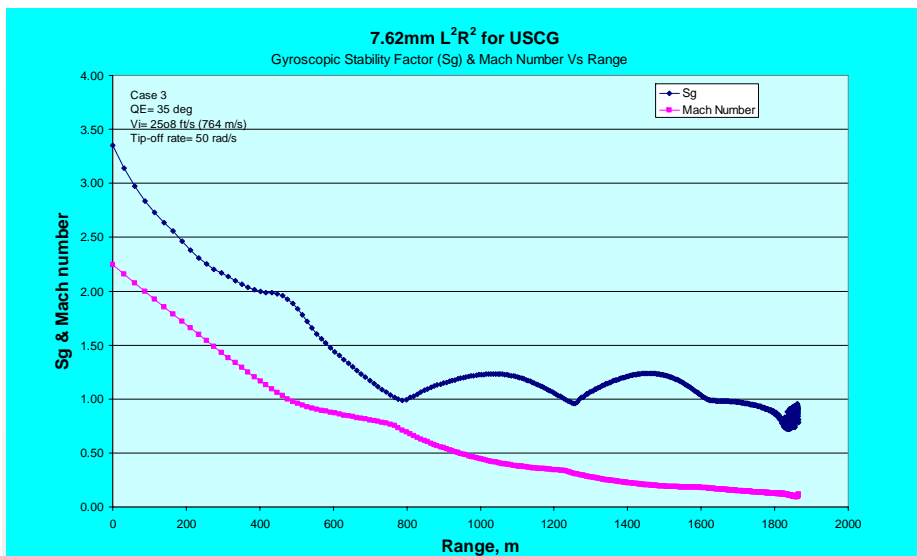



Design of Prototype Projectile

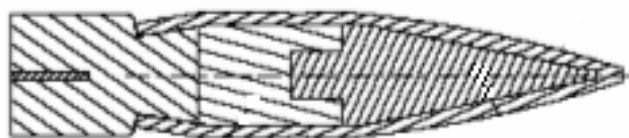
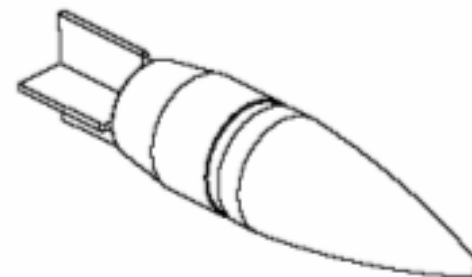
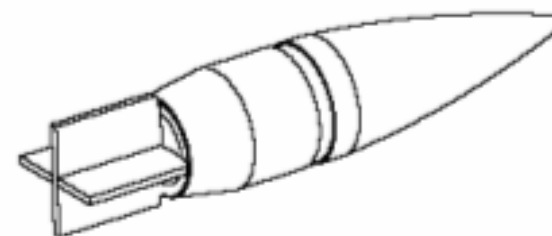

SECTION A-A





Design of Non-Finned Projectiles

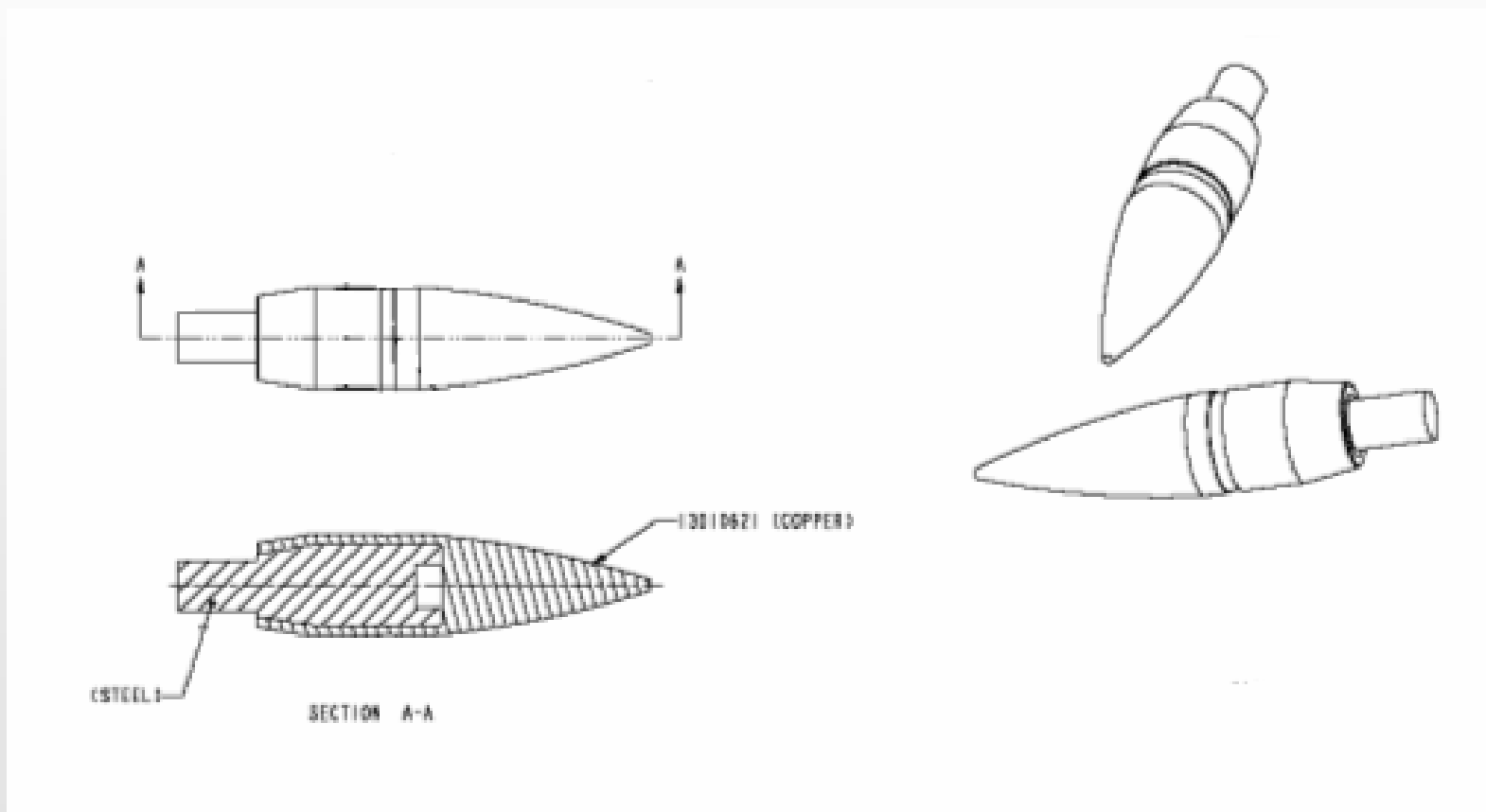



Test I:

Testing of Non-Finned Projectiles



- Test Projectile
 - Lead time shorter than finned prototypes
 - Facilitated charge establishment
 - Verified adequate case capacity was available
 - Occupied the same case volume rear of the cannellure
 - Verified weapon function and feeding
 - Identical CG to finned projectile
 - Identical ogive to finned projectile





Test II: Testing of Finned Prototypes

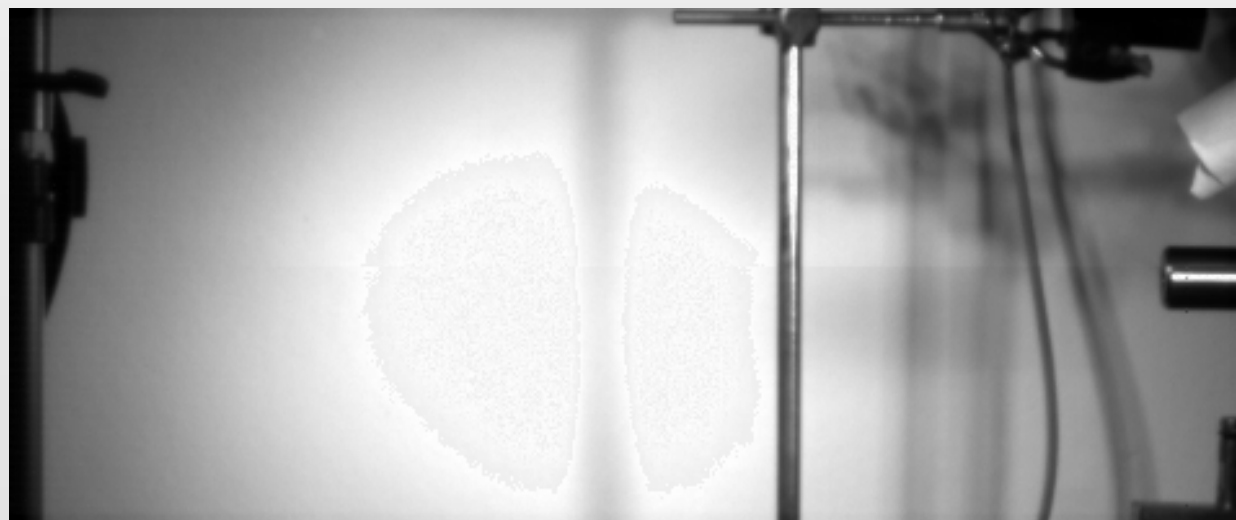



Corrective Actions to Projectiles

- Tightened tolerances on:
 - Jacket and internal parts
 - Boat tail
- Applied adhesive to internal mating surfaces





Test III: Testing of Finned Prototypes Rev. I

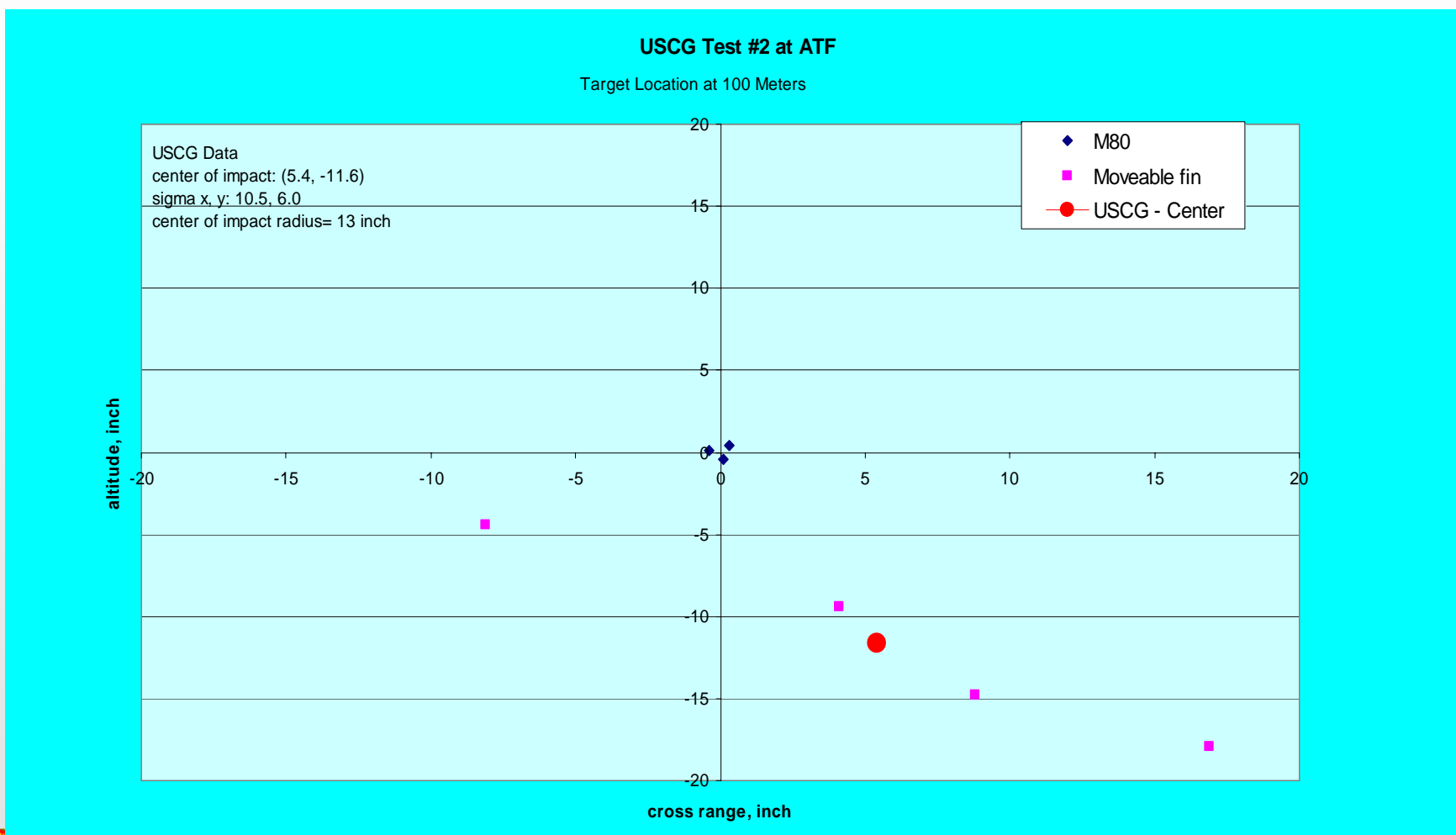



Corrective Actions to Projectiles

- Tighten Tolerances on boat tail
- High speed video indicated fins were deforming at launch
 - Fin nesting redesigned
- Eliminate anodization of fins





Test IV:



Testing of Finned Prototypes Rev. II

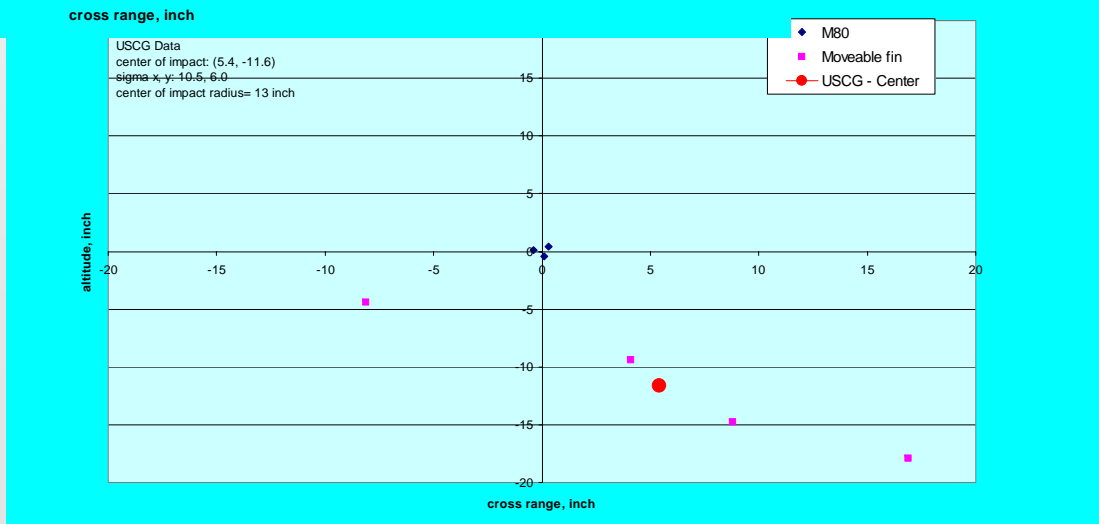
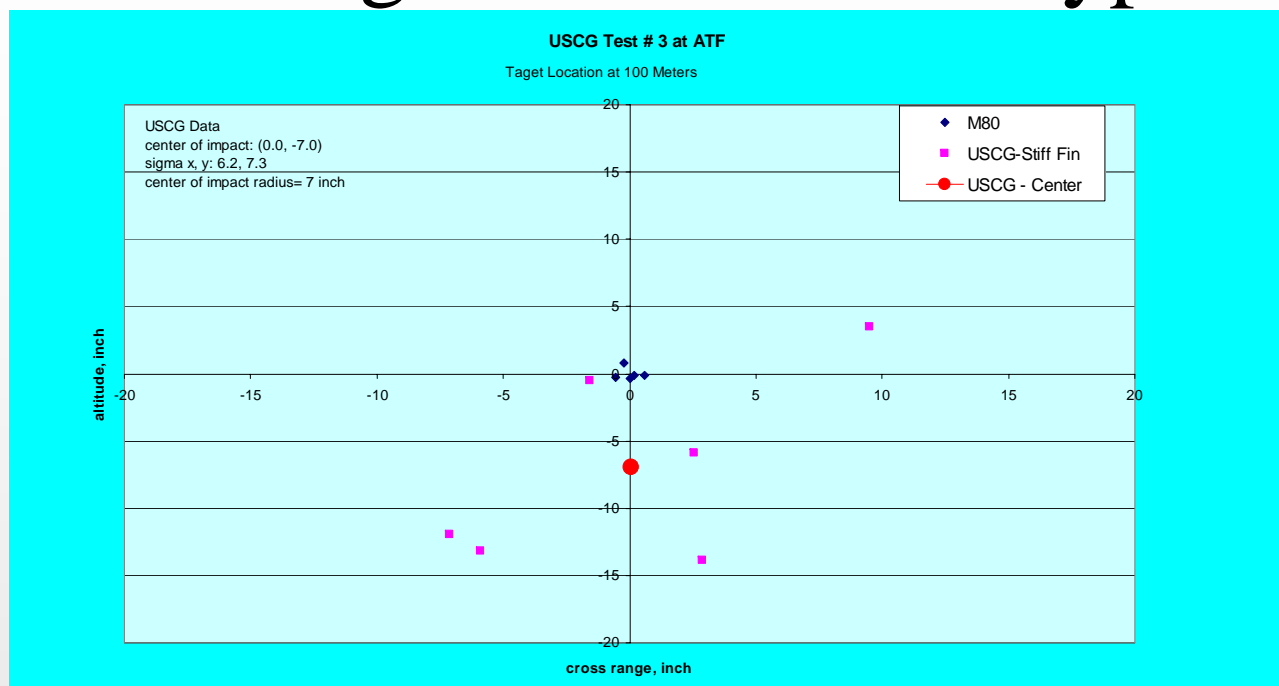



Test IV: High Speed Video





Test VI: Hard Target Penetration Testing

- 1/4" A36 Mild Steel
- 200 meters
- 60 degree obliquity angle
- 10 Rounds fired, ALL perforated





Summary

- Current projectile design satisfies penetration requirements
- Additional design modifications have been made to further improve accuracy
- Radar testing to verify the maximum range of the projectile has been scheduled

