



# Systems Engineering at Naval Postgraduate School

Eugene P. Paulo

Department of Systems Engineering

(831)-656-3452

[eppaulo@nps.edu](mailto:eppaulo@nps.edu)





## SE Department Mission

- Provide relevant, tailored, and unique advanced education and research programs in systems engineering in order to increase the combat effectiveness of U.S. and Allied armed forces and to enhance the security of the United States.**



# SE Department

- ❑ Chair: Dave Olwell
- ❑ 12 SE Primary Appointments
- ❑ 11 Joint Appointments
- ❑ Faculty are a mixture of retired military officers, industry, and new PhDs

# Systems Engineering Process for Conceiving, Creating and Sustaining a System

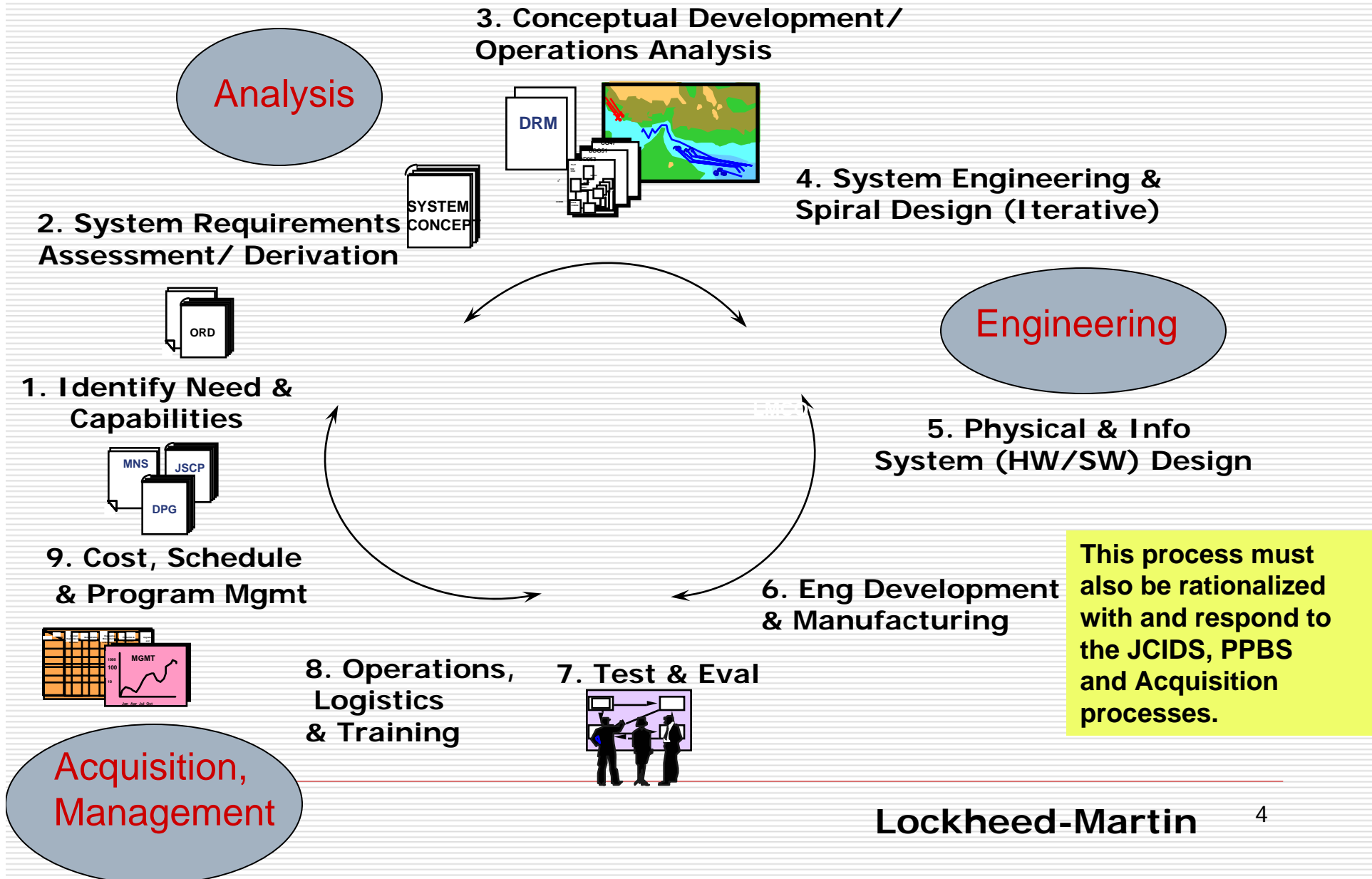



# Why Systems Engineering within DoD?

## □ Because we have to:

- The philosophy in DoD has shifted to integrate JCIDS, PPBS and Acquisition
- The paradigm in DOD has shifted from bottom-up service component system design (platforms and systems) to top-down, joint systems-of-systems integration
- DOD Acquisition 5000 Series now mandates systems engineering in all acquisition processes to ensure that new systems or components work in a System-of Systems environment
- Joint/"net-centric" operations now require top-down, joint concepts/capabilities that drive functions and requirements
- Rapidly changing technology and inserting new technologies enhances capabilities, but increases complexities and risks
- Increasing complexities and specialization requires partitioning systems into components and then managing their interfaces and integration



# What distinguishes SE at NPS?

- Broad and experienced faculty
- Students from DoD
- Focus on DoD problems
- Immersion in a technical domain
  - Combat Systems
  - Ship Systems
  - Network Systems
  - Operational Systems
- Inter-departmental delivery

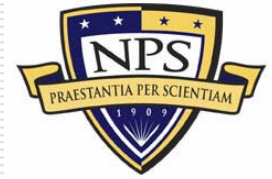

# NPS Aligned for Relevance and Excellence

Institutes ensure that the academic tools learned in the Schools are applied to military challenges.

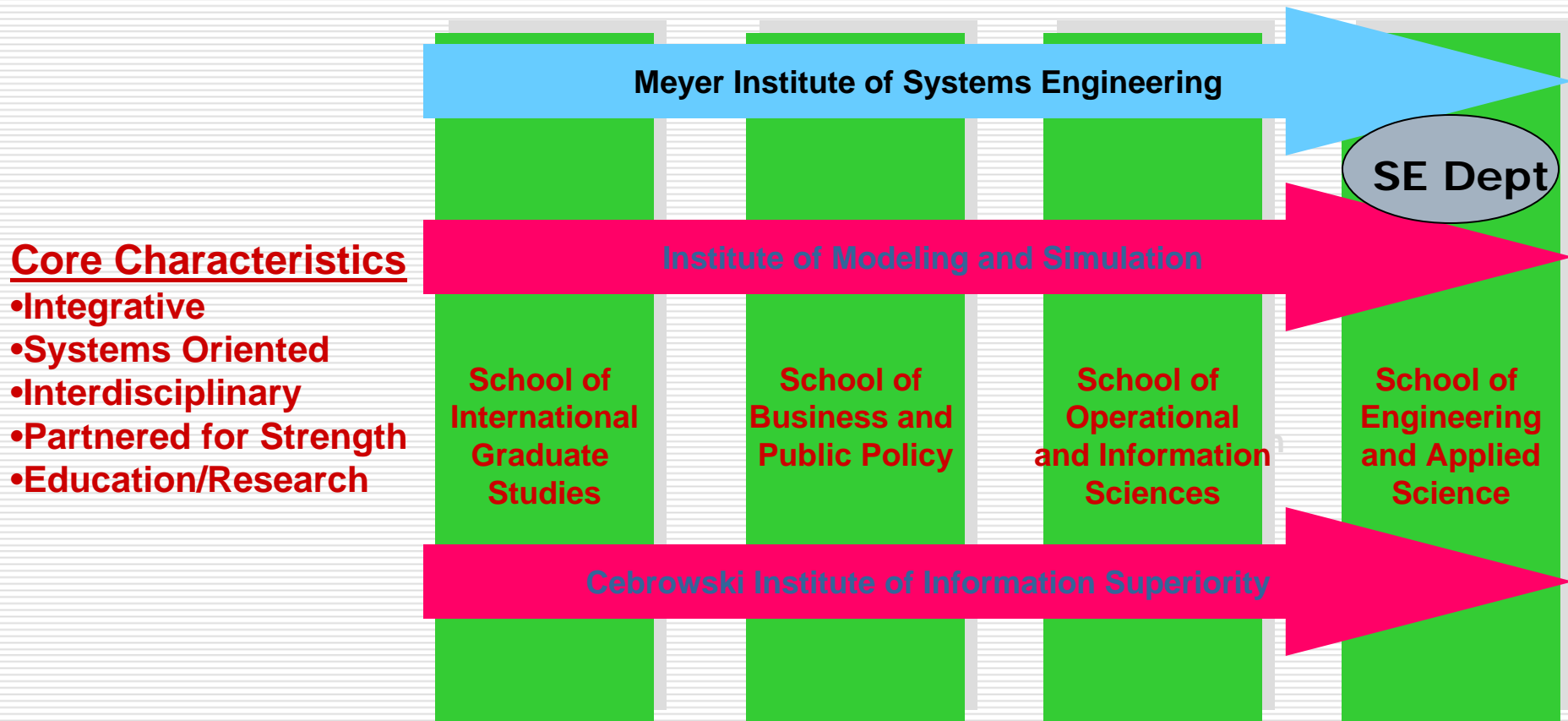

Graduate Schools provide the academic structure needed by students to cope with future challenges



# Curricula: Navy responses

- Existing Resident
  - URLs: Systems Engineering and Analysis (SEA) (about 60 students)
- Existing DL
  - Navy labs: MS SE program (about 150 students)
  - DoD civilians: PD21 (about 40 students)
  - DL Certificate in SE (60 seats in AY06)
- Started this summer
  - SE Minor for EDOs (45 per year at NPS)
  - Resident SE curriculum (10 students FY06)
- ***We are one of the largest graduate programs in the nation in SE (behind Johns Hopkins and Stevens), and growing rapidly***



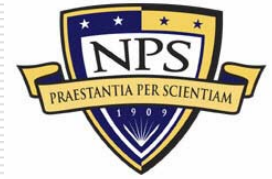

# Resident SE curricula

- Systems Engineering (curric 580)
  - Focused on Engineering officers
  - 9 quarters
  - 8 course specialization area
  - 9 course SE core
  - Project and thesis
  - Pulls on courses from Physics, OR, the other engineering departments
  - Includes ABET undergrad coursework
  - Can be tailored to a given domain area (e.g combat systems)
  - Launched this summer
  - Will seek ABET accreditation at earliest opportunity



# Non-resident curricula

## □DL Systems Engineering (curric 311)

- Primary focus is civilians in DoD with strong engineering backgrounds
- 8 quarters, two courses per quarter
- Group project, not thesis
- About 400 graduates to date
- Carries several DAU equivalencies
- Tailored to sponsor's needs
- Four starts per year

# Product Development 21/ Systems Engineering Management (curric 721)

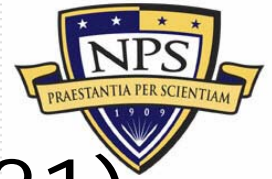

- MS Systems Engineering Management or MS Product Development
- Focused on students from civilian and military management level
- Twenty students per year
- Partnership with MIT / Detroit Mercy
  - Common curriculum
- 8 Quarters, two courses/ quarter
- Thesis



# Certificate Program

## □ Four course certificate in **systems engineering**

- Fundamental of System Engineering
- Fundamentals of Engineering Project Management
- System Suitability
- System Assessment
- On and off-campus offerings



# Certificate in **systems analysis**

## Four courses

- Probability and Statistics for Systems Engineers
- Combat System Simulation
- Tactical Analysis
- Systems Analysis

## Offered by OR Department

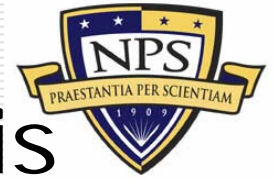

# Systems Engineering and Analysis (curric 308)

- Focused on unrestricted line officers
- 6 quarters
- Balance between technology, operations analysis, and systems thinking
- Group project, no thesis
- 6 years old, 11 cohorts to date

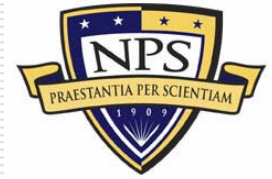

# Campus-Wide Integrated Projects

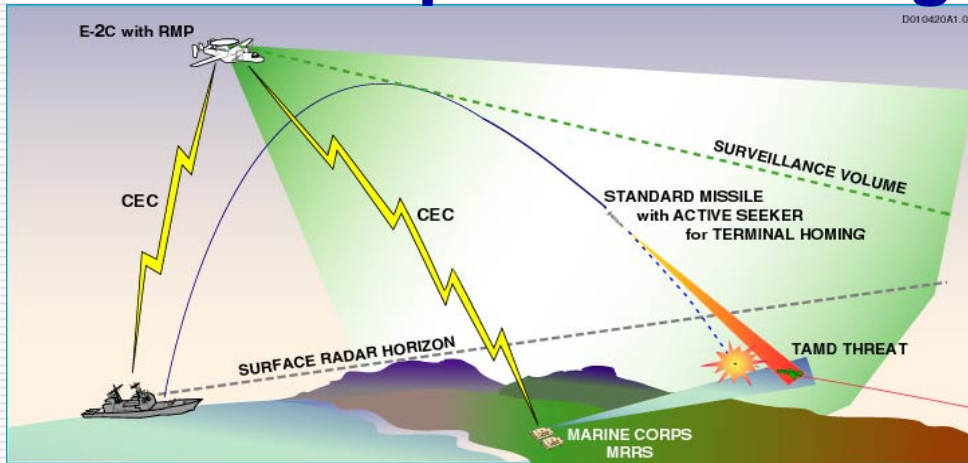

“Customer” with a problem

**Defense Problem**



NPS Student/Faculty Project

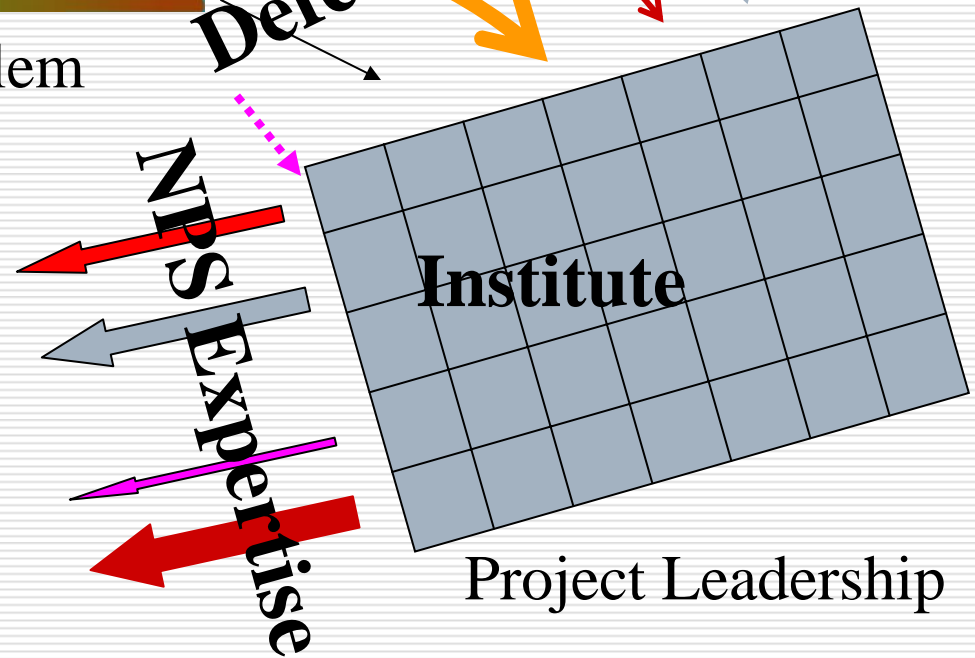



# Past Campus Wide Integrated Projects (with completion date)

- |  |                                 |
|--|---------------------------------|
| <input type="checkbox"/> Crossbow force; distributed aviation in the littoral; ship; UAVs                                    | <input type="checkbox"/> Dec 01 |
| <input type="checkbox"/> Expeditionary Warfare; SeaBase Ship; Heavy Lift A/C; C4I architecture; C4ISR satellite system; more | <input type="checkbox"/> Dec 02 |
| <input type="checkbox"/> Protection of the Sea Base  | <input type="checkbox"/> Dec 03 |
| <input type="checkbox"/> Unmanned Vehicles in Maritime Dominance   | <input type="checkbox"/> Jun 04 |
| <input type="checkbox"/> Joint Seabasing study with new OSD Joint Capabilities Office; major C2 architecture piece;          | <input type="checkbox"/> Dec 04 |



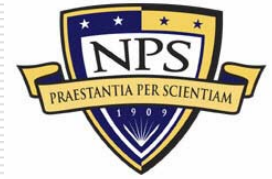

# Past Campus Wide Integrated Projects (with completion date)

- ❑ Maritime Dominance in the Littorals, completed June 2005
- ❑ Anti-submarine warfare in the Littorals, completed December 2005
- ❑ Joint Integrated Fires, to complete June 2006
- ❑ Sea Based TBMD, to complete June 2006
- ❑ Maritime Coalition Warfare in the Littorals, to complete June 2006

# **NPS Cross-Campus Integrated Study: Maritime Domain Protection in the Strait of Malacca**



**Brief 13 June 2005**

# NPS MDP Study Tasking



- “Design a conceptual system of systems to defeat and prevent terrorism in the Maritime Domain.” – Meyer Inst. Memo to SEA-7 Students 9NOV04
- Two Groups:
  - Maritime Domain Protection
  - Total Maritime Inspection System
- Integrated, 6-month study involving over 50 students, 20 faculty

[http://www.nps.navy.mil/sea/SEA%207%20\(MDP\)/index.htm](http://www.nps.navy.mil/sea/SEA%207%20(MDP)/index.htm)

# NPS MDP Study Overall Insights

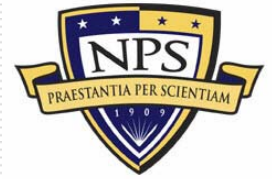

## MDP

- ❑ Wide-ranging, extremely difficult, highly interconnected, evolving problem
- ❑ Systems Engineering approach critical
- ❑ No single solution – threat specific
- ❑ Current capabilities mixed, depending on threat

## WMD Threat

- ❑ Adding Sea Inspection and improving Sensors & C3I capabilities gives small, low-cost benefit  
(20%Pd @ \$4B/10yrs)
- ❑ Land Inspection required for large benefit, but costly  
(80%Pd @ \$50B/10yrs)

# NPS MDP Study Overall Insights



## Ship As Weapon Threat

- ❑ "As-Is" Sea Marshal system effective  
(80%Pdef @ \$300M/10yrs)
- ❑ Improving Sensor range (not C3I capability)  
gives low-cost increase in time-to-respond  
(10-fold performance increase for 23% cost increase)

## Small Boat Attack Threat

- ❑ Feasible cost-effective solutions exist  
(90%Pdef @ \$500M/10yrs)
- ❑ Hardened Target required:
  - Active point defense
  - Passive protection (double-hull, hull coating)

# NPS MDP Study: Method

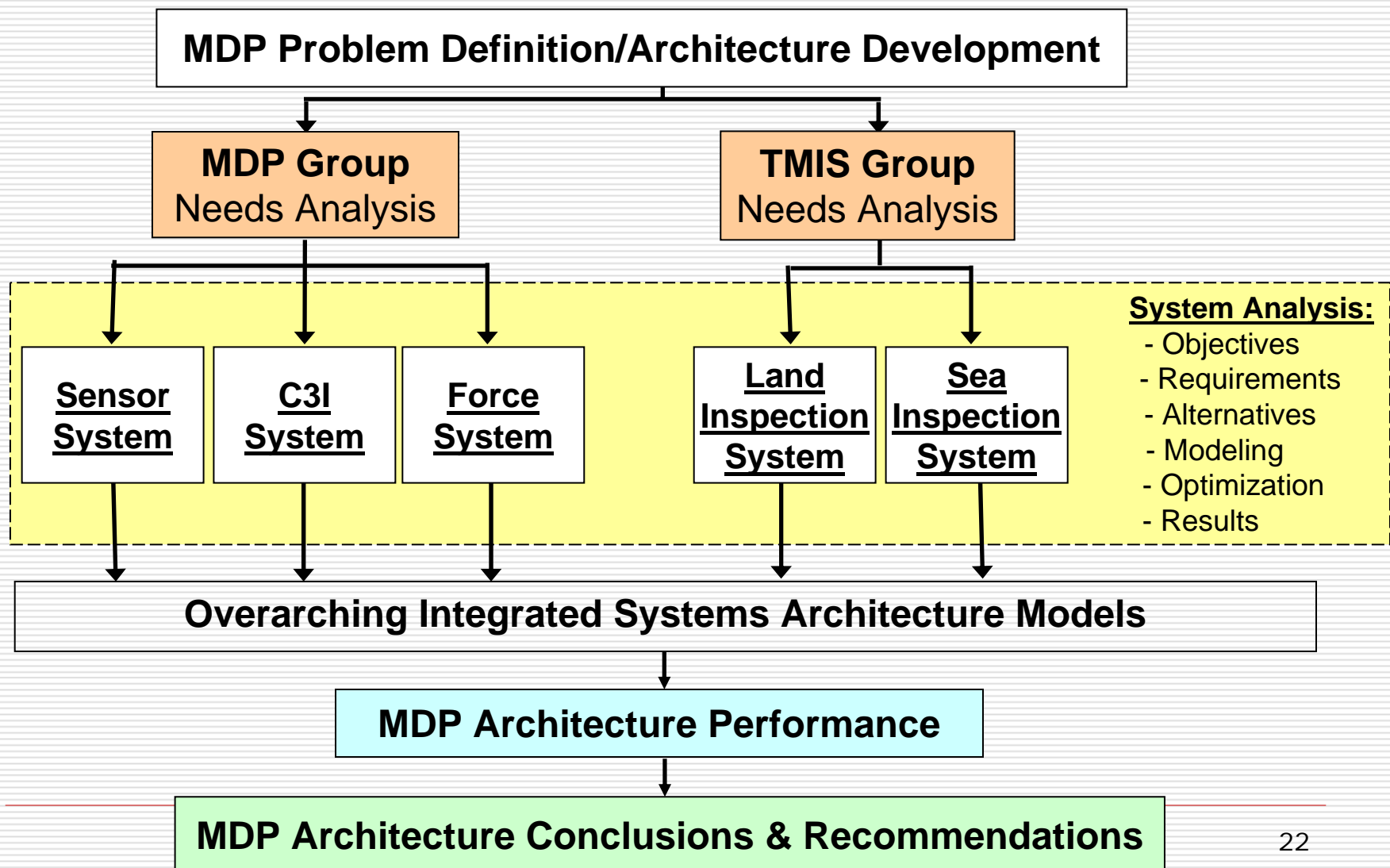



# Overall Architecture MOEs

## □ MOE 1 – Performance

- Does the system architecture defeat each attack with the required probability?

## □ MOE 2 – Risk (Expected attack damage)

- What is the expected attack damage cost for each threat scenario?



# Overall Architecture Metrics

## **Metric 1 – Commercial Impact**

- What is the expected cost to commerce over 10 years (through 2016)?
  - Commercial System Procurement Costs
  - Commercial System Operating & Support Costs
  - Commercial Delay Costs

## **Metric 2 – MDP System Cost**

- What is the expected MDP system cost over 10 years (through 2016)?
  - MDP System Procurement Costs
  - MDP System Operating & Support Costs
  - MDP System Delay Costs

**Total System Cost = Comm'l Impact + MDP Sys Cost**





# Current Campus-Wide Integrated Projects

- Design of a Functional, Physical, and Operational Joint Fires Systems Architecture
- Design of a Riverine Operational Force
- Completion dates for both are December of 2006.

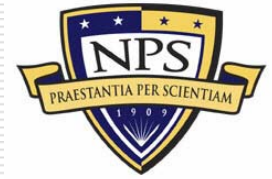

# Project One: Design of Joint Fires Systems Architectures

- There is an increased risk to any military mission if it cannot get the fire support it needs when it is needed**
- Military elements presented with opportunities for effective fire support may not be able to take advantage of them because they can't get timely support**
- Who determines which fire support provider can provide the most timely, effective support?**



# Project Partners

- JFCOM
  - Joint Fires Integration & Interoperability Team (JFIIT)
- Army TRAC-Monterey
- Marine Corps Fire Support Systems (AFATDS)
- AFIT
  - SE Faculty
  - TST Student Thesis
- NPS:
  - Multi-Discipline Faculty
  - OR, IS Students
  - SEA-10 Riverine
- National Training Center
- Air Warrior
- Joint Fires Coordination Measures JT&E
- Joint Air to Ground Operations Group



# Current Systems

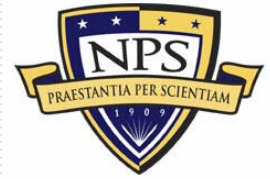



# F2T2EA Concept

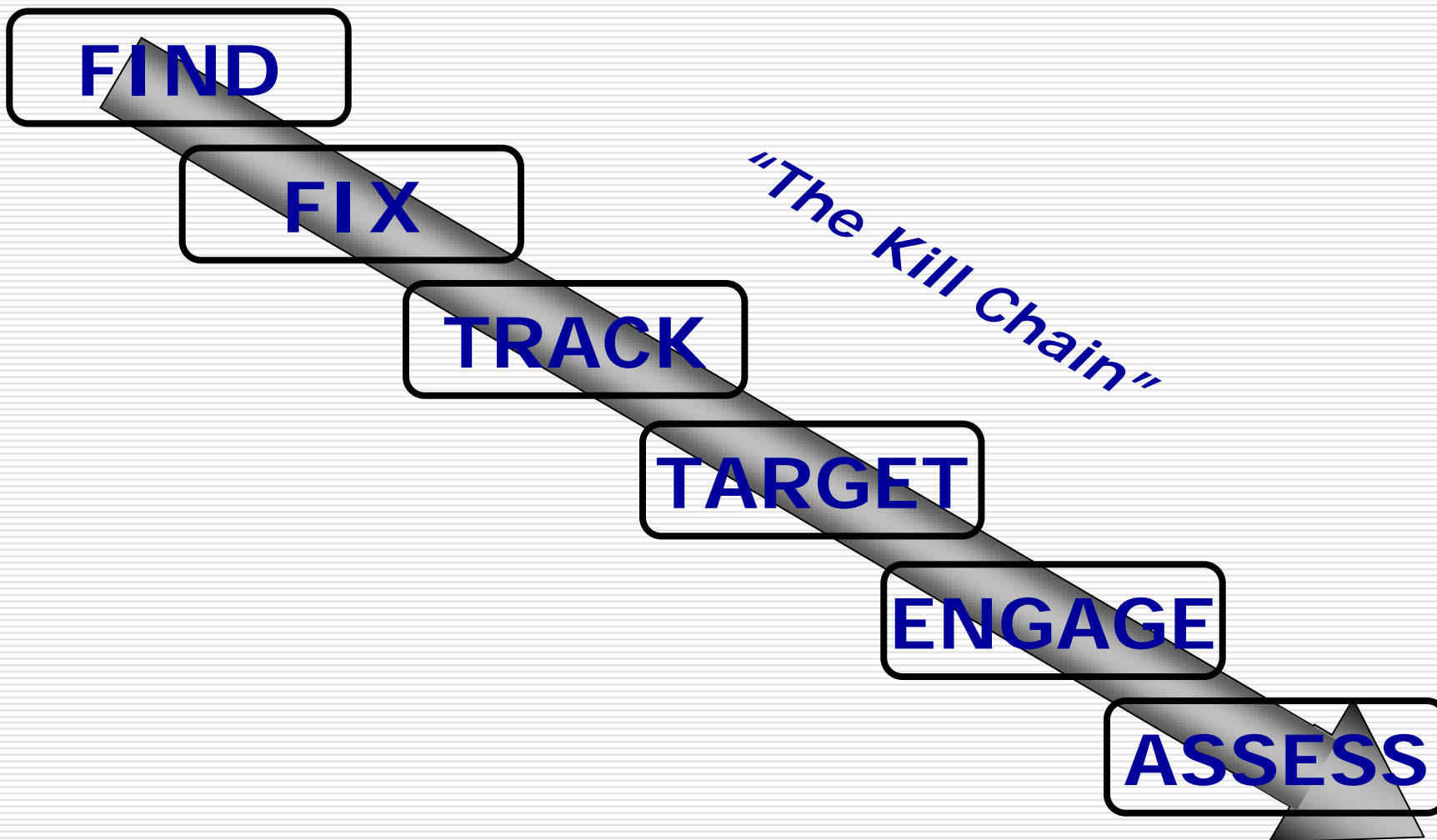



# Bounding the Problem

**TRACK**

Send Joint Fires Request

*'I need help!'*

**TARGET**

Process Request  
Select a Solution  
Task JF Provider  
Feedback to Requestor

**ENGAGE**

Provider Receives/Accepts  
Joint Fires Tasking

*'Help is on the way!'*

# Conceptual System



*Tasking*                      *Tasking*                      *Tasking*                      *Tasking*

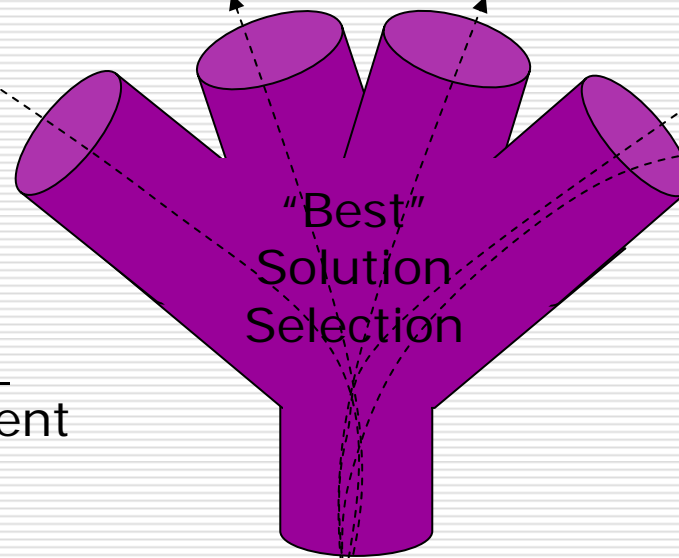

*Coalition  
Tasking*

"Best" Defined by:  
Commander Intent  
Availability  
Weapon Effects  
Target Characteristics  
etc.



Forward Element in  
Need of Fire Support



## Project 2: Riverine Operations

Determine a cost effective system of systems that enables the United States Navy riverine force to conduct surveillance, reconnaissance, and engage enemy threats within the riparian environment. The system focuses on improving battle space awareness and responsiveness in the detect to engage cycle. The architecture will consist of systems that are currently in service or could be in service by 2010.



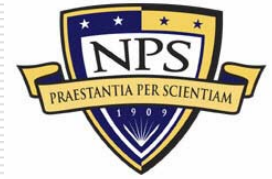

# Scenarios Being Considered



**Counter Trafficking**



**Patrol and Interdiction**



**Level II Threat Ambush**



# Possible Riverine Missions

- Blue Force Mission
  - Defend
  - Patrol and Interdiction OPS
  - Barrier
  - Target
  - Surveillance
  - Reconnaissance
- Red Force Missions
  - Attack
  - Transport
  - Transit
  - Defend

River Traffic

# Riverine Squadron Baseline



Tactical Operations Center  
 Level 1 Repair capability  
 15 days Logistic capability  
 Combat and Intermediate Medical capability  
 Motor transport capability



16 SURC



224 Personnel  
 (4) 7man boarding teams  
 17 security personnel

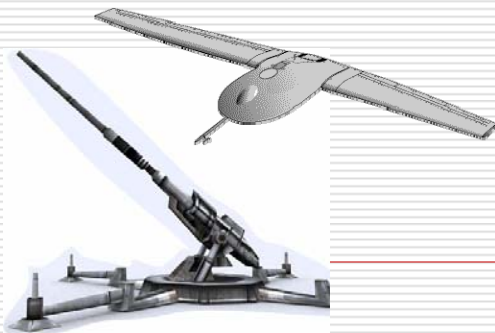

Inorganic supporting and combined arms.  
 Intelligence exploitation cells  
 Civil Affairs  
 Linguists  
 MTT



JMAST	NIPR	
GCCS	SIPR	
HF	UHF	
VHF	Iridium	35
SATCOM		

# Ongoing SE Department Research



- Modeling and Simulation to support Acquisition Professionals
- SE tools and processes for the Rapid Equipping Force
- 2007 DARPA Grand Challenge
  - With attention to IED sensor support