



Defense View on Considerations for System of Systems SE

25 October 2006

Kristen Baldwin
Systems and
Software Engineering
Office of the Under
Secretary of Defense
(AT&L)

Dr. Judith Dahmann
The MITRE Corporation

Robin Gullifer
Systems and
Software Engineering
Office of the Under
Secretary of Defense
(AT&L)



Purpose and Overview

- Purpose of Presentation
 - Provide an update on AT&L SE activities to support capabilities and systems of systems
- Overview of Topics
 - Background
 - Recent events
 - INCOSE, QDR Portfolio Test Cases, DoD SW Strategy Summit
 - New initiative
 - DUSD (A&T) directed OSD-led effort to develop and publish System-of-Systems (SoS) Systems Engineering Guide
 - Way Ahead



Evolving Perspectives on SoS SE

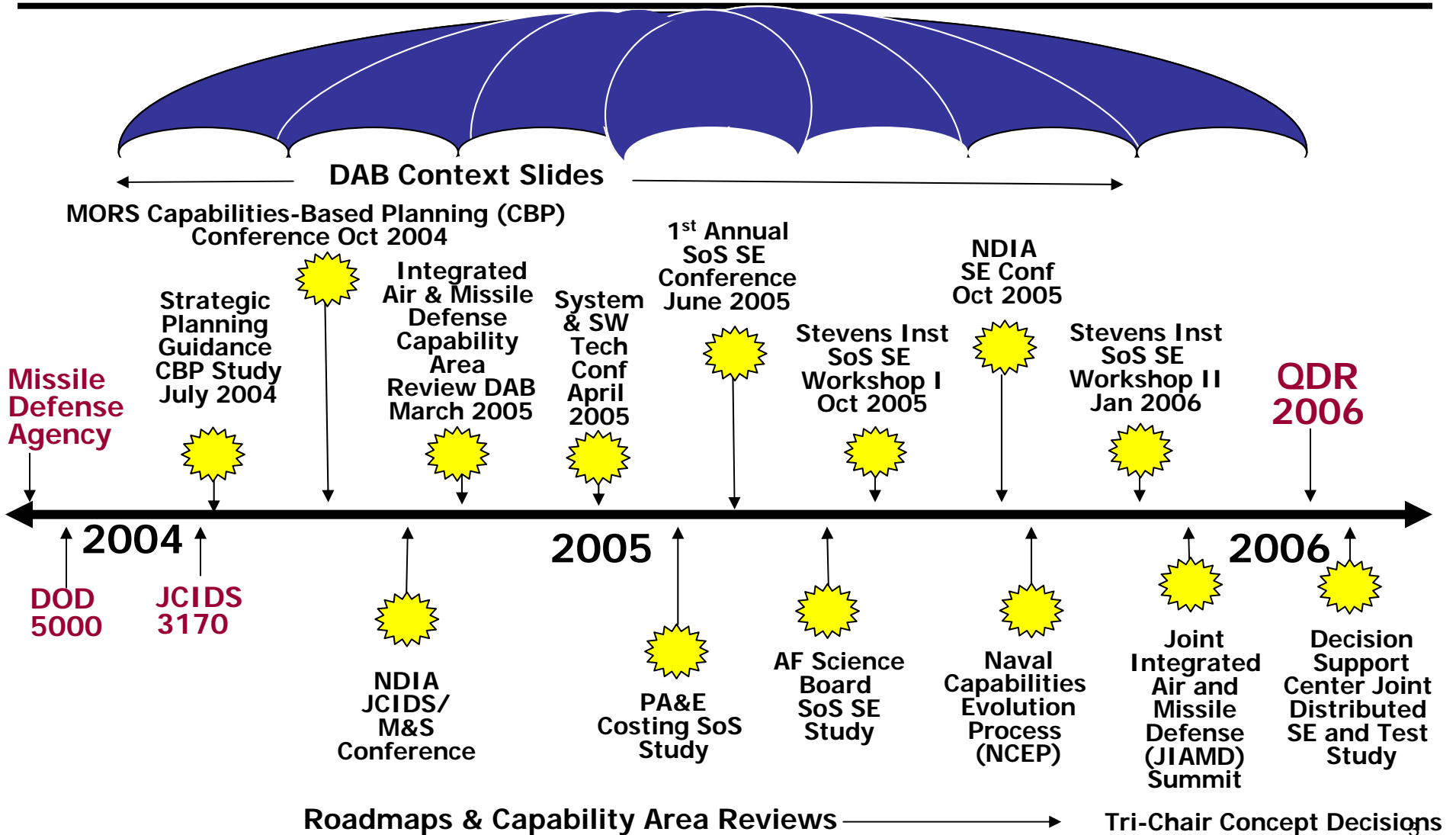



INCOSE Panel on System of Systems July 2006

- One of a number of events addressing issues of SOS
- Series of presentations from academia and industry
- Quotable quotes
 - “There is no nice line between Systems and SoS”
 - “There is no difference between SE for systems and SOS...”
 - “There is a simply a need for better requirements management for SoS...”
 - “Thinking that traditional SE methods/techniques are sufficient for SOS is dangerous..”
 - “Standard SE applies but requires extensions”
 - “Only difference is no one in control in a SOS....”
 - “Nothing is new. Any system that has sub-systems is a SoS. We have been doing this forever.”

Wide range of perspectives on SOS and SE today



Defense Considerations for SoS

- **Scale**
 - Size of defense enterprise makes a single integrated architecture infeasible
- **Ownership/Management**
 - Individual systems are owned by the military component or agencies, introducing constraints on management and SE
- **Legacy**
 - Given defense budget projections, current systems will be part of the defense inventory for the long-term and need to be factored into any approach to SOS
- **Changing operations**
 - Changing threats and concepts mean that new (ad hoc) SoS configurations will be needed to address changing, unpredictable operational demands
- **Criticality of SW**
 - SOS typically focus on integration across systems through cooperative or distributed software
- **Role of network**
 - Conceptually DOD SoS will be network based; budget and legacy challenges of budgets and legacy mean uneven implementation



QDR Implementation

SE for Capability Portfolio Test Cases

... there is a **need for systems engineering support to** ensure that the set of **capability solutions** – including legacy, planned, and programmed efforts – is coordinated so as to maximize the solutions' effectiveness and ensure their timely delivery to the warfighter...

Systems engineering will provide the technical base for selecting components of the systems needed to support portfolio objectives, for identifying the technical aspects of the of those systems critical to meeting the larger portfolio capability goals, and **for defining and assessing the end-to-end performance of the system of systems...**

... engineering of the systems will remain the responsibility of the program managers or components... **system of systems engineering function will address technical aspects of design, configuration, and system integration that are critical to meeting joint capability objectives...**

Deputy Secretary of Defense Capability Portfolio
Management Test Case Guidance, 14 Sept 2006

- Quadrennial Defense Review directed DOD move towards a portfolio approach to force development based on Joint capabilities
- Four test cases have been initiated
- In each case SE is seen as a portfolio level function



Defense SW Strategy Summit October 2006

Top Software Issues NDIA

1. The impact of requirements upon software is not consistently quantified and managed in development or sustainment.
2. Fundamental system engineering decisions are made without full participation of software engineering.
3. Software life-cycle planning and management by acquirers and suppliers is ineffective.
4. The quantity and quality of software engineering expertise is insufficient to meet the demands of government and the defense industry.
5. Traditional software verification techniques are costly and ineffective for dealing with the scale and complexity of modern systems.
6. There is a failure to assure correct, predictable, safe, secure execution of complex software in distributed environments.
7. Inadequate attention is given to total lifecycle issues for COTS/NDI impacts on lifecycle cost and risk.

HDR Systems Engineering Division - Top SW Issues
Report#25,2006
Version 1.0a

Opportunities for Improvement

- Development environments for net-reliant embedded systems must:
 - Readily embrace emerging data and knowledge management strategies
 - Automatically facilitate and assess interoperability and protocol implementation compatibility
 - Address system-of-systems design
 - Properties-in-the-large, composable, security
 - Accommodate data and functional uncertainties associated with ad-hoc networks and transient application relationships
- System-of-Systems Verification

QDR highlights need for Systems of Systems

- Purpose
 - Focus efforts on top DOD SW issues
- Panels & workgroups
 - PEOs, SEs, SW experts
- Recurring topic of SOS
 - SW Challenges
 - PEO and Service initiatives
 - Research efforts

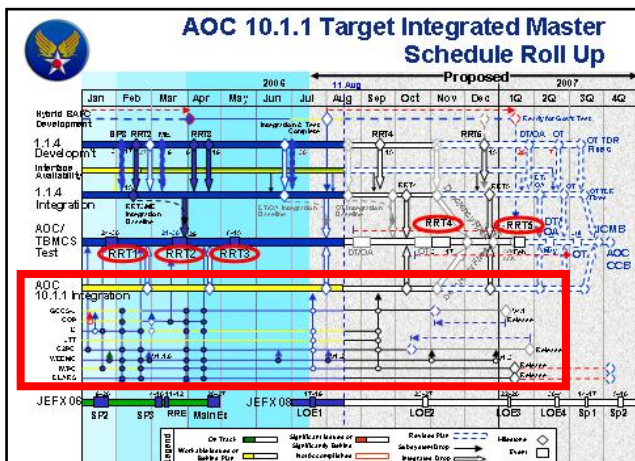

Strategic Initiatives

Focus Area	Initiative
Process and People Focus	1. Acquisition Process Improvement <i>Foster migration to a model-based approach for continuously improving the software and software intensive systems across the Army</i>
	2. Measurement <i>Increase the visibility of software metrics in system management/development</i>
	3. Training & Education <i>Prepare Army leadership, Program Managers, and Staffs to meet the technology and management challenges inherent to the acquisition of software intensive systems</i>
Technology Focus	4. Architecture <i>Institutionalize knowledge and practice of software architecture to improve quality, lower costs, and reduce cycle times for software and software intensive systems</i>
	5. System of Systems Integration <i>Develop strategies and techniques to identify and resolve issues in meeting system of systems, net-centric, capability-based requirements for interoperability and joint war fighting</i>
Future Focus	6. Analysis & Strategic Planning <i>Investigate new challenges and opportunities</i>

SW is a key element of SOS



Profiling the Context for SE: One Model

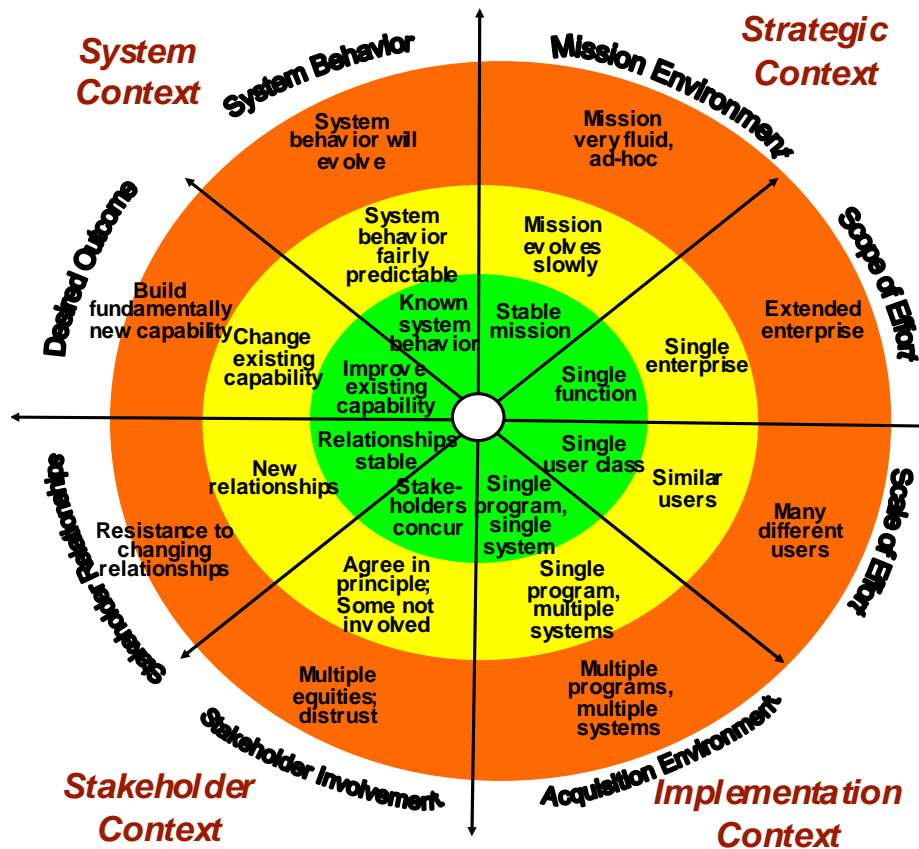

- Typical program domain**
 - Traditional systems engineering
 - Chief Engineer inside the program; reports to program manager
- Transitional domain**
 - Systems engineering across boundaries
 - Work across system/program boundaries
 - Influence vs authority
- Messy frontier**
 - Political engineering (power, control...)
 - High risk, potentially high reward
 - Foster cooperative behavior



SoS SE Guide

- DUSD (A&T) directed OSD-led effort to develop and publish System-of-Systems (SoS) Systems Engineering Guide
- Purpose
 - Leverage current experience to support ongoing efforts to develop, field and sustain SoS
 - Focus on technical aspects of SE applicable across SOS management constructs
- Version 1
 - 6 month effort addressing areas of agreement across the community
- Audience - Program Managers and Lead/Chief Engineers
- Development Participants
 - Lead by AT&L Systems and Software Engineering
 - IPT with representatives from Services and Agencies
 - Stevens Institute is the integrating author

Draft (Version .1) of Guide is now out for review



The Guide Addresses

- Definitions
- Scope
- Characteristics of the SOS environment
- Illustrative DOD use cases
- Challenges and approaches to SE processes



Definitions

Draft SOS SE Guide

System

An integrated composite of people, products, and processes that provide a capability to satisfy a stated need or objective

Mil-Std 499B

System of Systems

A set or arrangement of systems that results when independent and useful systems are integrated into a larger system that delivers unique capabilities

DoD Defense Acquisition Guide, System of Systems Engineering

System of Systems Engineering

Planning, analyzing, organizing, and integrating the capabilities of a mix of existing and new systems into a SoS capability greater than the sum of the capabilities of the constituent parts

DoD Defense Acquisition Guide, Chapter 4



Scope Spectrum Of Issues

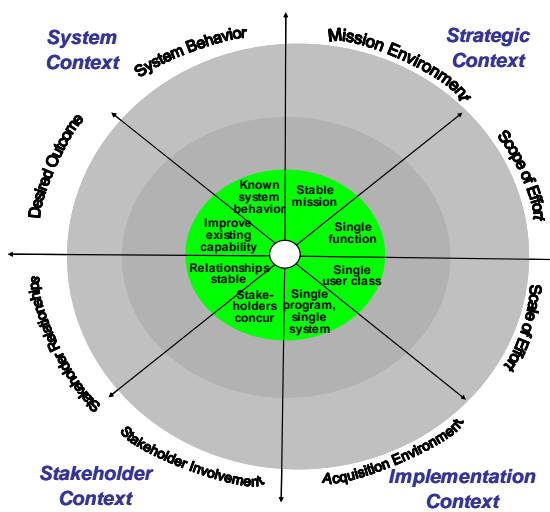

Current Systems Engineering Practices

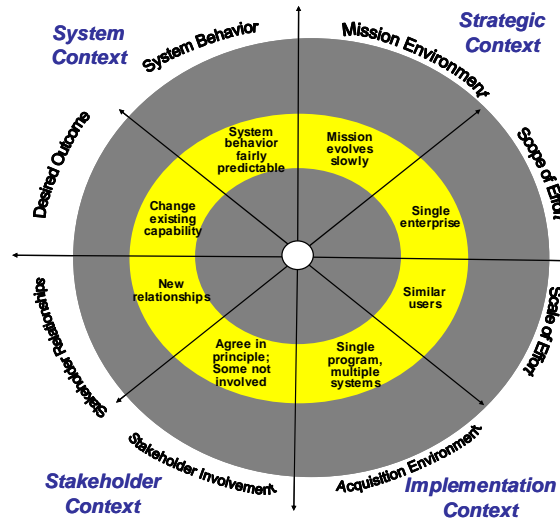

Focus of Initial Version of SOS SE Guide

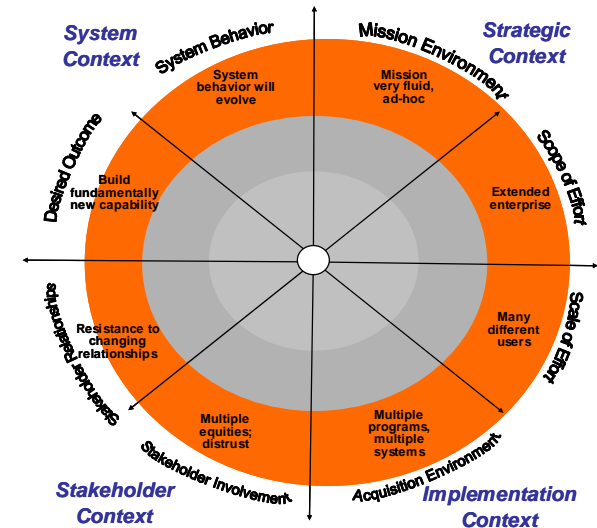

Challenges

SoS cases under the well-defined circumstances where there is

- (1) defined user need
- (2) resources designated to address the need and
- (3) someone has the responsibility to address the need



Draft SoS SE Guide

Characterizing the SoS Environment

Community Involvement: Stakeholders, Governance

System: stakeholders generally committed only to the one system

SoS: stakeholders more diverse; stakeholders from each system will have some interest in the other systems comprising the SoS

Employment Environment: Mission Environment, Operational Focus

System: mission environment is relatively stable, pre-defined, and generally well-known; operational focus is clear

SoS: emphasis on multiple missions, integration across missions, need for ad hoc operational capabilities to support rapidly evolving mission objectives

Implementation: Acquisition/Test And Validation, Engineering

System: aligned to ACAT Milestones, specified requirements, a single DoD PM, SE with a Systems Engineering Plan (SEP), test and validating the system is possible

SoS: multiple system lifecycles across acquisition programs, involving legacy systems, developmental systems, and technology insertion with multiple DoD PEOs, PMs and operational and support communities; testing is more difficult, and test and validation can be distributed and federated





Defense Experience With SoS SE Several Examples

- New Development
 - Future Combat System (FCS) and Integrated Deepwater System (IDS)
- Development of New Capability by Integrating Current System
 - Army Battlefield Command System (ABCS)
- Mixed System Maturity Levels
 - Naval Integrated Fire Control-Counter Air (NIFC-CA) and Single Integrated Air Picture (SIAP)
- Sustaining Capabilities
 - Stryker Brigade Combat Team (BCT)
- IT/Business
 - Commissary Advance Resale Transaction System (CARTS)

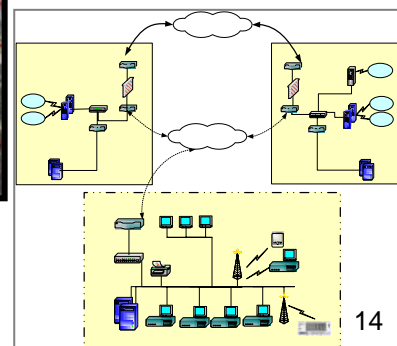
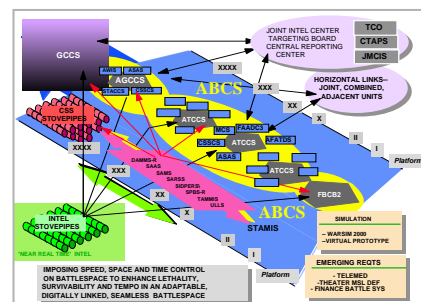



Draft SOS SE Guide

Challenges of SoS for SE Processes

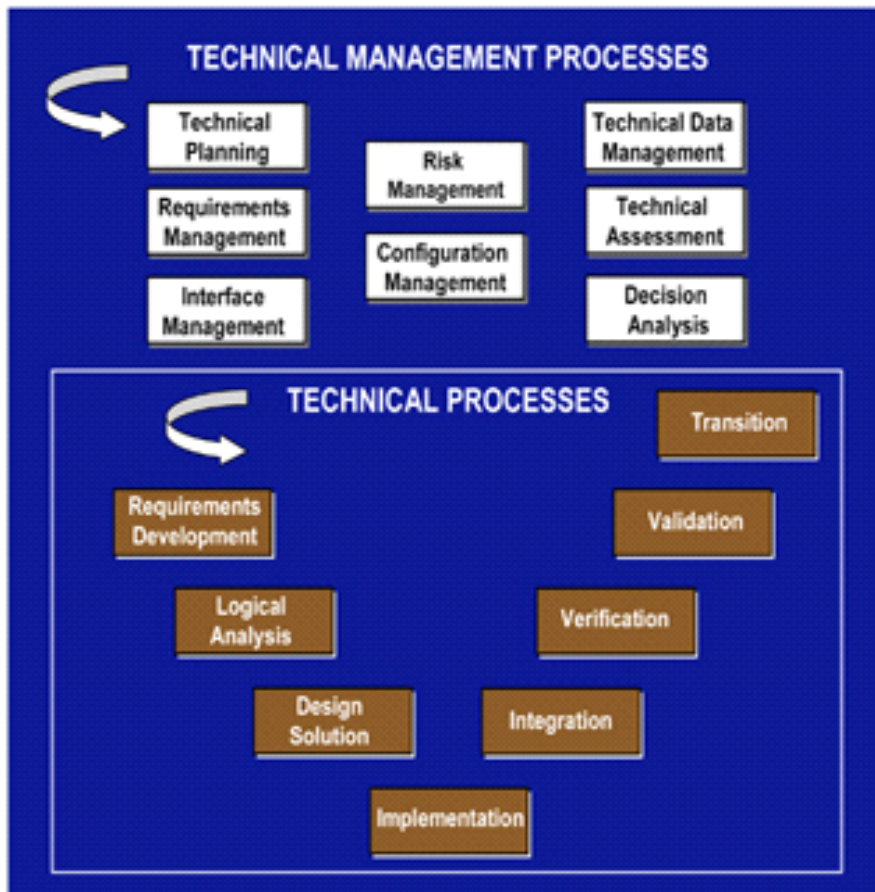

From Chapter 4 Defense Acquisition Guide

- Technical and Technical Management Processes for SE
 - Identify implications of SOS for each process
 - Challenges these pose for the SE
 - Approaches to address the challenges
- Processes apply, but the SOS environment affects approaches, methods and tools needed by SE
 - More collaboration, less top down
 - More complexity to accommodate requirements, approaches and tools used by constituent systems
 - Balance between roles of SOS SE and the system SE
 - More need for experimentation to determine ways to employ existing systems and to discover effects of combined systems



Next Steps

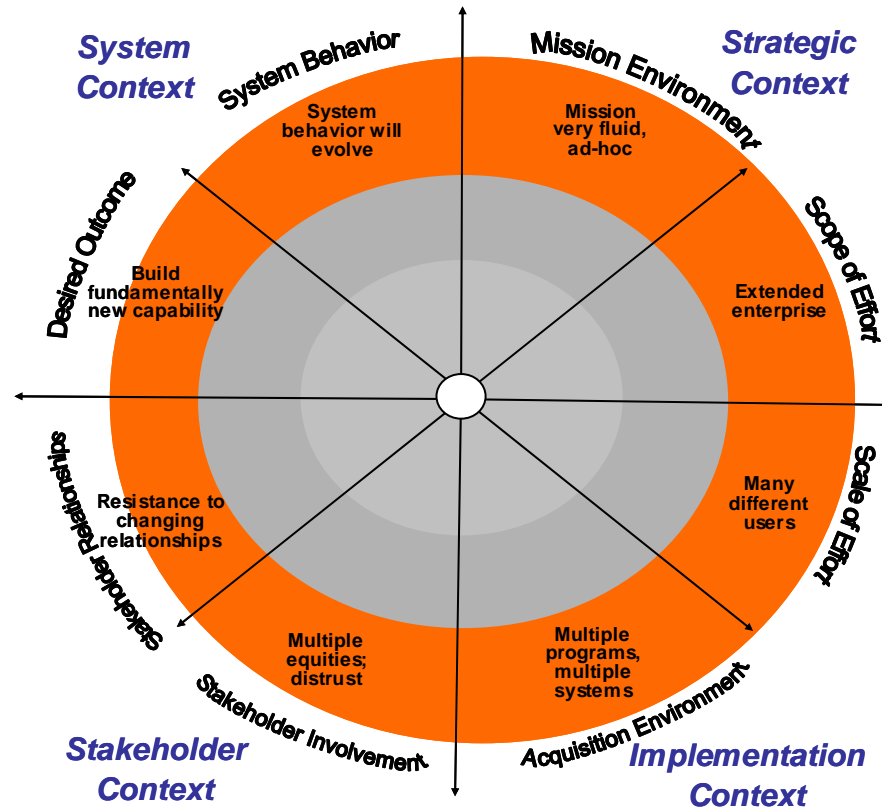

Challenges Version 2 and Beyond