



Culture



Value Engineering Tools for Contractor Support

Dwayne Porter
Castings and Forgings
614-692-8857/DSN 850-8857

Mark Cutler
Sustaining Engineering
614-692-4939/DSN 850-4939



Agenda



- Castings & Forgings
- Value Engineering Change Proposals (VECP's)
- Replenishment Parts Purchase or Borrow (RPPOB)
- Sustaining Engineering (SE)
- Additional VM Programs Managed at DSCC
- Future Vision of DSCC's VM
- Summary
- Value Engineering Program Points of Contact



Castings and Forgings

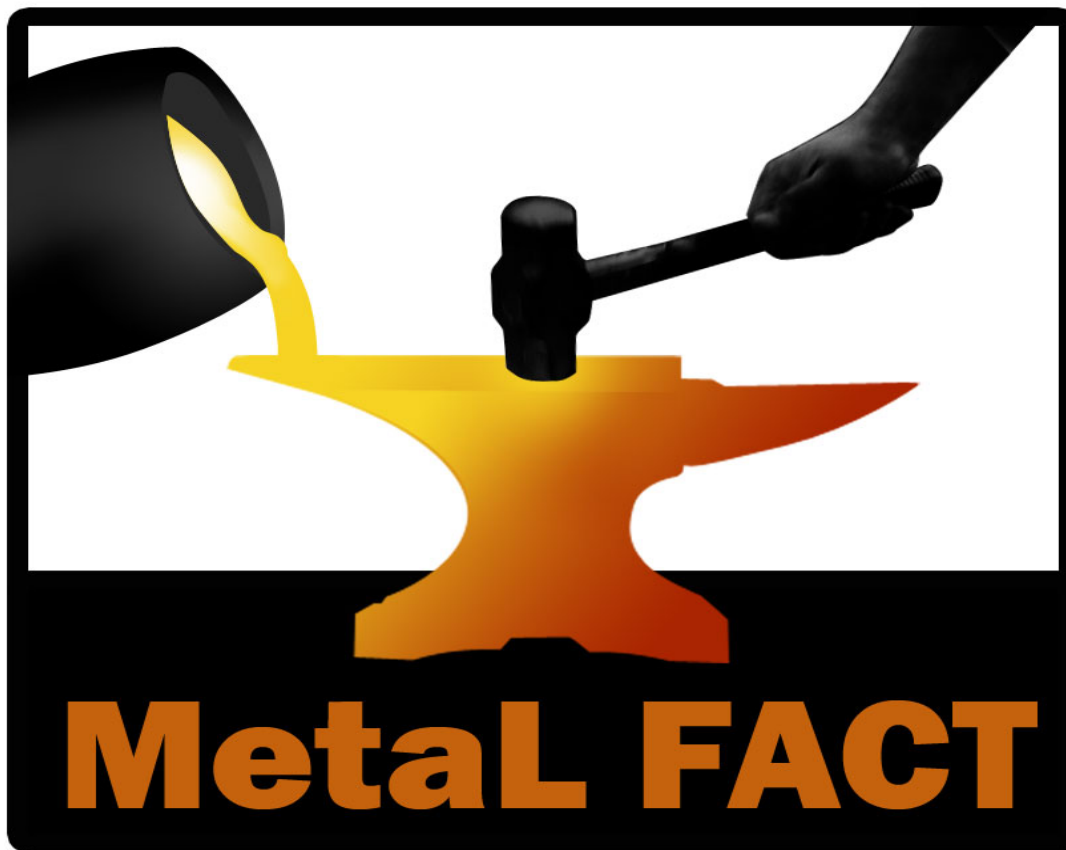

Maritime & Land Forging And Casting Team



Castings & Forgings



- Castings are complex metal shapes
 - Structural, mechanical, engineered applications
 - Formed from liquid metal, produced in a mold
 - Often are “hidden” components of an assembly
- Forgings can be complex or simple shapes
 - Forging is heated metal, but not molten
 - Formed by pounding or pressing it into the desired shape
 - Sometimes tooling is required,
 - Sometimes are “hidden” components of an assembly



DLA's Goal

Procure high-quality, cost-effective cast or forged parts for weapon systems to meet readiness requirements



Procurement Issues



- Long lead times
- Defaulted contracts
- Identifying cast or forged parts/components at the assembly level
- Tooling availability
- Diminishing manufacturing sources
- Low quantity procurements
- Contracting to correct sources





A Common Plan



- HQ DLA has implemented two programs
 - Shared cost between Government and Industry
 - Address key technical needs
- Castings for Improved Readiness (CIR)
 - Supported by American Metalcasting Consortium (AMC)
 - Managed by Advanced Technology Institute (ATI)
- PRO-FAST
 - Supported by Forging Defense Manufacturing Consortium (FDMC)
 - Managed by ATI
- Programs focus on three areas
 - Resolve casting/forging part problems
 - Training for Government personnel
 - Research & Development



Strategic Direction



- Ensure a viable casting or forging supply chain future
- Apply new technologies
- Reduce administrative and production lead times
- Utilize extensive casting and forging experience and knowledge to solve supply chain backorders
- Incorporate AMC/FDMC information into DLA's procurement processes to improve readiness



Remember, When Using AMC or FDMC they...



- Do not change your contractual responsibility
- Are not part of your contract
- Won't charge you, or won't pay you
- Are available to consult and assist
- Are an industrial organization, not government
- Cannot approve any tech data changes
- Cannot change anything in the terms and conditions of the contract



DSCC's MetaLFACT Team



- Provides casting & forging assistance
- MetaLFACT is comprised of Government and Industry representation
- MetaLFACT is a resource available to the following:
 - DSCC Personnel: Product Specialists, Buyers, Planners
 - Engineering Support Activities (ESAs)
 - Contractors/Suppliers
 - With active DSCC contracts (w/Contracting Officers' approval)
 - Bidding on open DSCC solicitations





How MetaLFACT Provides Assistance



- **Process and Material** - Understand the required casting or forging process and material (may be buried in a OEM specification and not be apparent)
 - **As-cast or forged tolerances**
 - **Surface finish requirements**
- **Sourcing** – Identify capable sources when unable to manufacture due to unresponsive supply chain
- **Tooling** – Find source for tooling when unable to manufacture due to unavailable tooling
- **Technical Field Support** to foundry/forge, process, design, manufacture, or other problems
- **Update TDP** with current specifications, processes, etc and their interpretation
- **Assist Engineering Support Activity** in expediting required engineering analysis/response



Additional Casting Resources

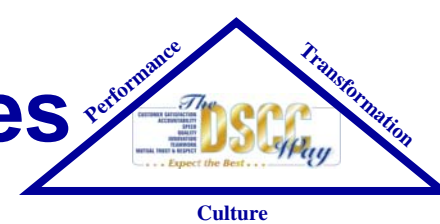

- **Defense Tooling Locator**
 - <http://www.defensetooling.net>
- **Steel Founders Society of America**
 - <http://www.sfsa.org>
- **America Founders Society Inc.**
 - <http://www.afsinc.org>
- **North American Die Casting Association**
 - <http://www.diecasting.org>
- **Non-Ferrous Founders Society**
 - <http://www.nffs.org>
- **American Metalcasting Consortium**
 - <http://www.amc.aticorp.org>

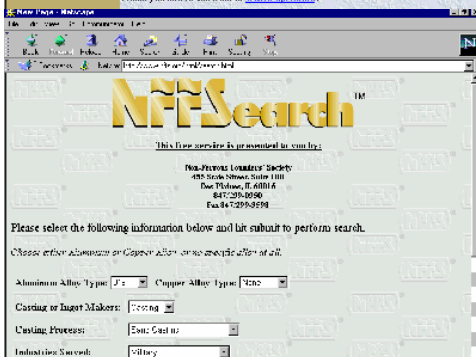
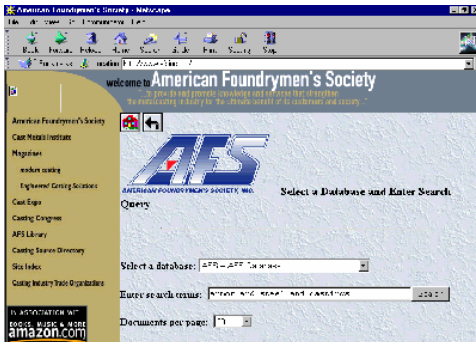
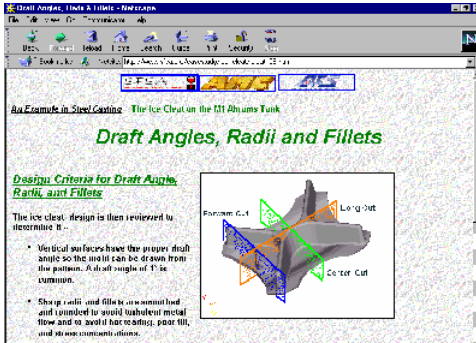



Additional Casting Resources

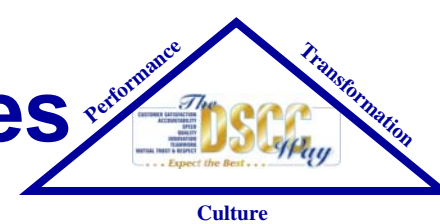

- **American Metalcasting Consortium**
 - <http://www.amc.atcorp.org>
- **Defense Casting Suppliers**
 - <http://www.defensecastingsuppliers.com>
- **Defense Tooling Locator**
 - <http://www.defensetooling.net>
- **Steel Founders' Society of America**
 - <http://www.sfsa.org>
- **American Foundry Society**
 - <http://www.afsinc.org>
- **North American Die Casting Association**
 - <http://www.diecasting.org>
- **Non-Ferrous Founders' Society**
 - <http://www.nffs.org>

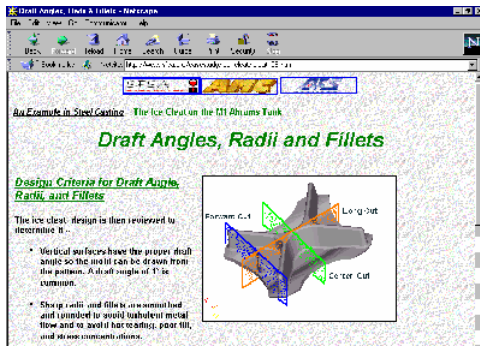

AMC



Additional Forging Resources

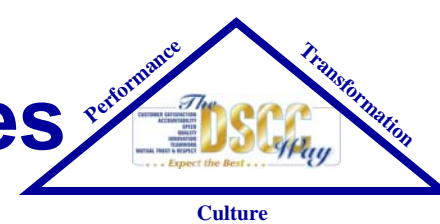

- **The Forging Industry Association (FIA) website:**
 - <http://www.forging.org>
- **FIA website for Custom Forging Producers:**
 - <http://forging.org/bgguide/index.cfm>
- **Forging Defense Manufacturing Consortium**
 - <http://www.fdmc.aticorp.org>

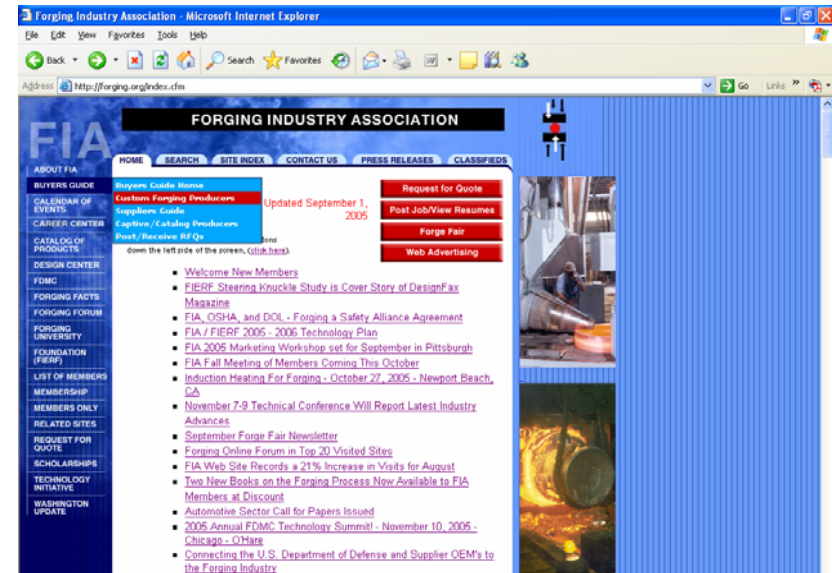



Yoke: Universal Joint



NSN 2520-00-679-9246

- Used on M113 Armored Personnel Carrier
- Supplier had no forging source
- FORGE-IT Team
 - Located forging source
 - Located tooling
- Enabled on-time delivery
- Lead time savings over 100 days
- Tooling cost avoidance of \$25,000





Compressor Rotor



- Used on LA Class Subs
- Sole source item sold through various levels of distributors
 - Price escalated
- DLA funded Navy Keyport to reverse engineer and develop a technical data package
 - AMC assisted with review
- New source awarded contract
 - Items passed First Article Testing
 - DSCC saved over \$250K

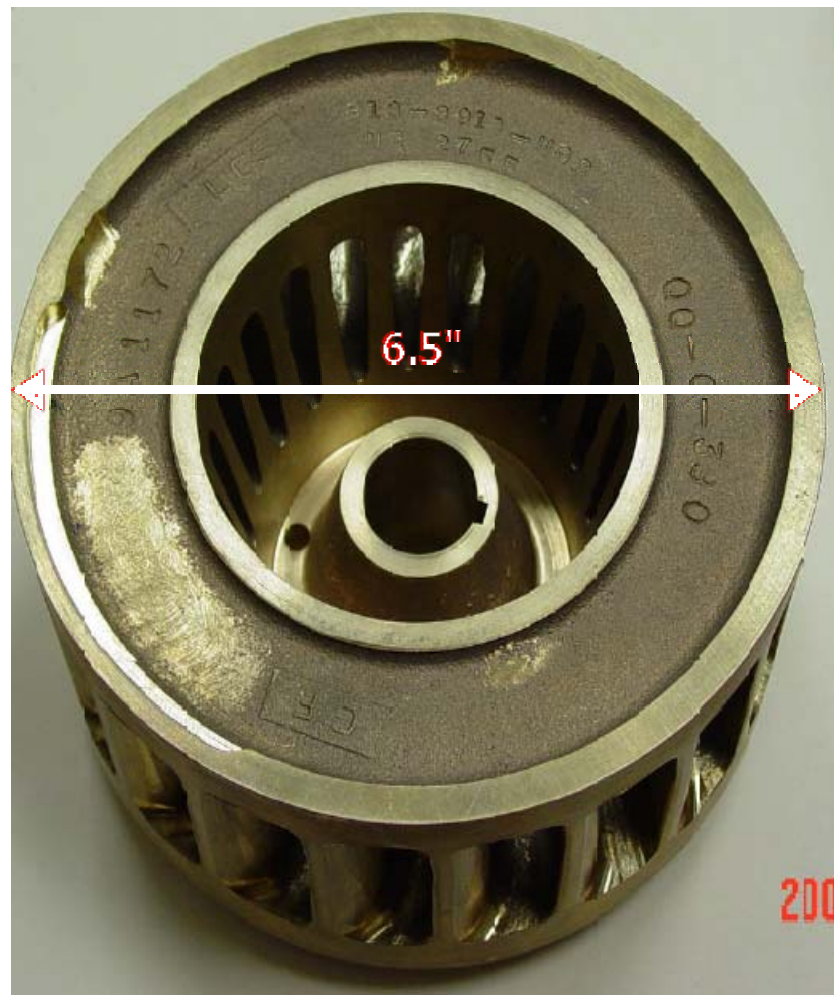



Value Engineering Change Proposals

VECPs



Value Engineering Change Proposals



- Contractual method to share savings
 - Improve DoD supplies and/or equipment
 - Savings shared between Contractor and DoD
 - Described in FAR Clause 52.248.1
- Improvements include any price savings
 - Processes
 - Materials
 - Manufacturing techniques
 - Other





Rules and Tools



- VECP clause in all DSCC contracts > \$25K
- Clause can be added by modification
- VECP can only be received on an instant contract
- Typical share ratio: 50/50
- Collateral lifecycle savings may be negotiated



Desiccant Canister



NSN 4440-01-004-8602

- VECP submitted by Drytech Inc. resulted in significant lifecycle savings and increased lifespan for the waveguides on F-15 Aircraft radar
- After a strenuous approval process, Drytech Inc. received \$55,036 for the approved VECP





Replenishment Parts Purchase or Borrow Program

RPPOB



Why RPPOB



- Statutory Requirement
 - Defense Procurement Reform Act of 1984
 - Public Law 98-525, Section 1216(a)
 - Codified at Title 10 U.S.C. 2320(B)
 - Promote full and open competition
 - Develop new sources
 - Sole Source
 - Limited Competition Items

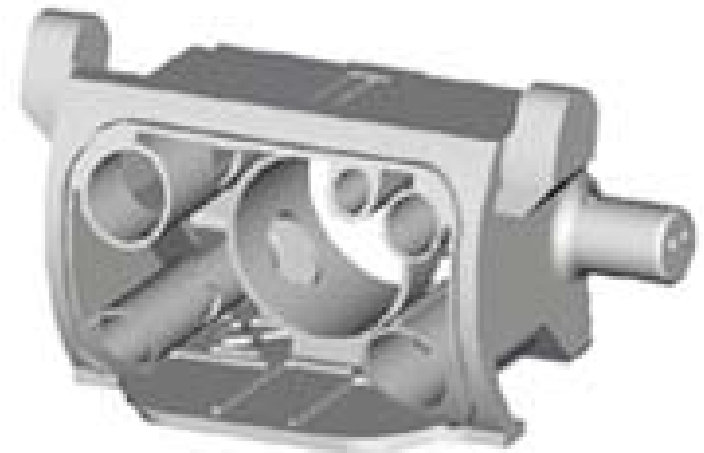



RPPOB Methods



- Direct Purchase
 - Contractor purchases at Standard Unit Price (SUP)
 - Item is not returned
- Bailment
 - Item loaned at SUP
 - SUP held in Trust by DFAS
 - SUP monies returned
 - If item is returned in “A” condition
- View of Part
 - Contractors may inspect part in a designated area

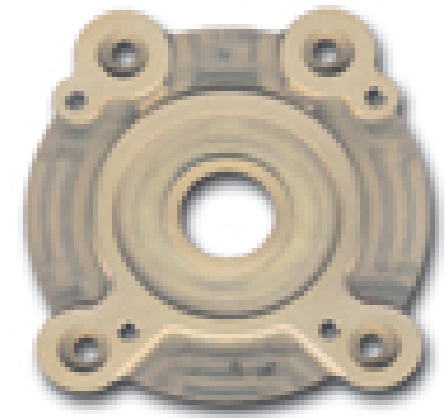



RPPOB – What it is Not



- Not intended to proof their manufacturing
- Not available on solicitations/contracts when:
 - In accordance with a drawing
 - In accordance with a specification
- Not to test a competitor's part



Purpose: Develop New Sources



RPPOB Process



- Contractor request received
- Item reviewed as an RPPOB candidate
- Contact with ESA for approval to bail out
- Contractor provides monies and signs the agreement
- Item directly sent to Contractor
- Contractor provides alternate offer data package
- Data package sent to ESA for final approval
- System updated with approval



Benefits



- Break Sole Source
- Provide additional sources on limited source items
- Provide source for obsolete items
- Reduce cost through enhanced competition
- Potential for Unlimited Rights TDPs

Increased Competition = Lower Cost to Taxpayers



Sustaining Engineering Program

SE



Sustaining Engineering



- Improve/upgrade DLA-managed items
 - New technology
 - Quality/reliability improvements
 - Ease of maintenance improvements
 - Improve logistics footprint
- Save money!!
- DLA initiates SE Program
 - Aviation items
 - DSCR: Jan 03
 - Land and Maritime items
 - DSCC: Jan 04





DSCC Sustaining Engineering



- Proposals solicited from all services
- Proposals evaluated by DSCC team
 - Value Management Team lead
 - Weapon System Support Manager (WSSM)
 - Cognizant Maritime/Land Application Team
 - Engineer/technical
 - Product Assurance
 - Buyer
- Selections funded/implemented in order of
 - Date of receipt
 - Weapon system support impact
 - Overall best value to customer
- Accepted proposals funded by DSCC
 - Coordinated with ESA
 - Funds available FY07: \$5M





Project Selection Criteria



- DLA/DSCC managed item
- Minimum ROI of 10:1
 - Lifecycle savings
- Make positive impact
 - Operational readiness
 - ALT/PLT
 - Item demand
 - Unit price
- Reduce field maintenance actions
- Improve competitive position
 - Availability of tech data
 - Increase sources of supply





Naval Transmitter Buoy



NSN 5820-01-500-7012

- Upgrade Transmitter Buoy to a single buoy to replace the current four-buoy system used by all US Navy submarines
- Benefits include:
 - Four NSNs cancelled
 - Four Allowance Parts Lists (APL's) replaced with one
 - Shipboard storage space reduced
 - 50% reduction in acquisition cost
 - CONUS source



Investment: \$409K

ROI: 24:1

Project Savings: \$10M



M-134 Mini-Gun Wear Gage



NSN 1005-00-903-0933

- Rock Island Arsenal (RIA) developing barrel wear gage for M-134 Mini-gun
- Barrels currently replaced every 100,000 rounds fired
- Barrel wear gage will assess remaining barrel life
- RIA estimates a lifespan of over 200,000 rounds a barrel
- Extending barrel life will reduce support and operating cost

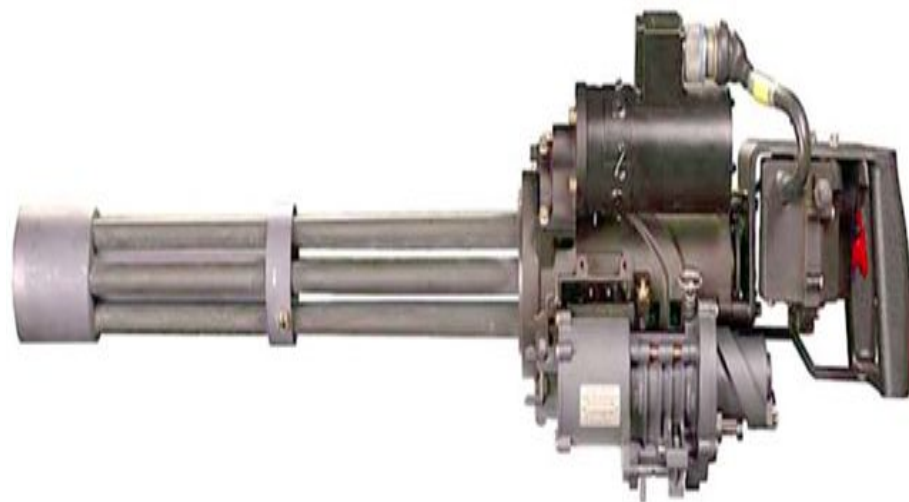

Investment: \$115K

ROI: 31:1

Project Savings: \$4.5M



Additional Value Management Programs Managed at DSCC



Additional VM Programs



Price Challenge Program

- Responsive to customer suspicion of overpricing
- Determination of value using technical data, procurement history, and similar items
- Provide recommendation when overpricing is discovered
- Corrective action taken to improve pricing or recover funds

Should Cost Program

- Engineering Intrinsic Value Cost Estimate
 - Materials and labor
 - Testing
 - Packaging
 - Manufacturing Charges
 - Overhead and Profit
- Results assist Contracting Officers during procurement negotiations





Additional VM Programs



Reverse Engineering

- Performed using Government resources
- Items ordered from Government stock
- Engineer determines material, mechanical, electrical, physical and environmental properties
- Testing requirements are identified/determined
- Technical Data Package developed for use in full and open competitive acquisition



Organic Manufacturing

- Support hard-to-buy procurements by utilizing manufacturing capacity of government labs/arsenals when private industry cannot meet our needs
- **Public** (organic) and **Private** sources cannot compete against each other for awards!
 - Exceptions:
 - **Price**: quoted price is formally determined to be unacceptable
 - **Delivery**: quoted delivery time frame does not meet our requirements.



Future Vision of DSCC's VM



- Transition to Supply Chain Management
 - Focus on Land and Maritime managed NSNs
 - Includes Detachments at DSCR and DSCP
- Expand Sustaining Engineering
 - Develop relationships with ESA's/Program Offices
 - Collaborate on new projects for problem NSNs
- Increase Reverse Engineering Projects
 - Develop data packages on NSNs bought by code/part number
 - Increase capabilities with partnered labs
- Provide Added Support to L&M Contracting Functions
 - Increased capability for Price Challenge/Should Cost
 - Focus on problem NSNs by weapon system



Summary



- DSCC's Value Management Office provides support
 - Government
 - Customers
 - Suppliers
- Our focus
 - Provide solutions on problem parts
 - Reduce acquisition and support costs
- For further information
 - Contact attached P.O.C.'s
 - Visit our booths: #715 & #716 on DSCC row



Overall Goal: Support the Warfighter



Points of Contact



VM Program Manager: Dave Szczublewski

614-692-8854 / DSN 850-8854 / david.szczublewski@dla.mil

VEB Team Chief: Dan Krist

614-692-3320 / DSN 850-3320 / daniel.krist@dla.mil

VEE Team Chief & VECP: Mitchell McElroy

614-692-8824 / DSN 850-8824 / mitchell.mcelroy@dla.mil

Castings & Forgings: Dwayne Porter

614-692-8857 / DSN 850-8857 / dwayne.porter@dla.mil

RPPOB: Daniel Bonner

614-692-4203 / DSN 850-4203 / daniel.bonner@dla.mil

Sustainment Engineering & VECP: Mark Cutler

614-692-4939 / DSN 850-4939 / mark.cutler@dla.mil

Organic Manufacturing: Jeff Culbertson

614-692-8833 / DSN 850-8833 / jeffery.culbertson@dla.mil

Price Challenge & Should Cost Teams: Andy Utz

614-692-8758 / DSN 850-8758 / andrew.utz@dla.mil
