

Joint Services Power Expo

April 24-26, 2007

“Solving power supply obsolescence, reliability, and power density issues by advances in power electronics technology”

Rich Sidley

Custom Manufacturing & Engineering



CUSTOM MANUFACTURING & ENGINEERING, INC.

A Power & Sensors Company

- **Integrated Power Supplies, Power Distribution & Management Products**
- **Remote Sensors & Monitoring Networks**
- **Obsolescence Solutions**

Problems

- 1995 DOD policy change allows military to integrate COTS into weapon systems.
 - COTS \neq Military requirements.
 - Peak availability and lowest pricing of a given component may last only six to 18 months.
- Higher power densities \rightarrow higher switching frequencies.
 - More RFI/EMI but can be handled by smaller components.
 - Layout (resonance).

COTS ≠ Military

- Special technical requirements for military power supplies fall into three main categories:
 - Environmental:
 - High temp:
 - Semiconductor MTBF halves for every 10 °C increase in operating temperature.
 - Low temp:
 - LCDs.
 - Capacitor dielectric.
 - Crystallization of potting compounds.
 - Shock and vibration resistance.
 - Dust.
 - Moisture.

COTS ≠ Military

- The special technical requirements for military power supplies fall into three main categories:
 - Input and output voltage:
 - Military specifications are stringent for low and high line conditions and voltage spikes, surges and excessive input ripple.
 - Output voltages are often non-standard when compared with commercial products.

COTS ≠ Military

- The special technical requirements for military power supplies fall into three main categories:
 - Electro-magnetic compatibility:
 - COTS does not necessarily pass any EMI standards
 - Military limits typically 10 Hz to 1 GHz, adding a range of conducted and radiated susceptibility and emissions requirements.
 - FCC and Europe's EN55022 are lower bandwidth, etc.

COTS ≠ Military

- Additional glue components:
 - Input and output conditioning are needed to achieve compliance.
 - Active filters remove spikes and filter both conducted emissions and conducted susceptibility such as transients or input ripple appearing at the output.
 - Radiated emissions are dealt with by complete screening of the final power supply.
- Considerable certification testing.

Military COTS

- Some components are called “Military COTS” but still are not self-sufficient to meet all military and system requirements.

CME's Generic Military Power Supply

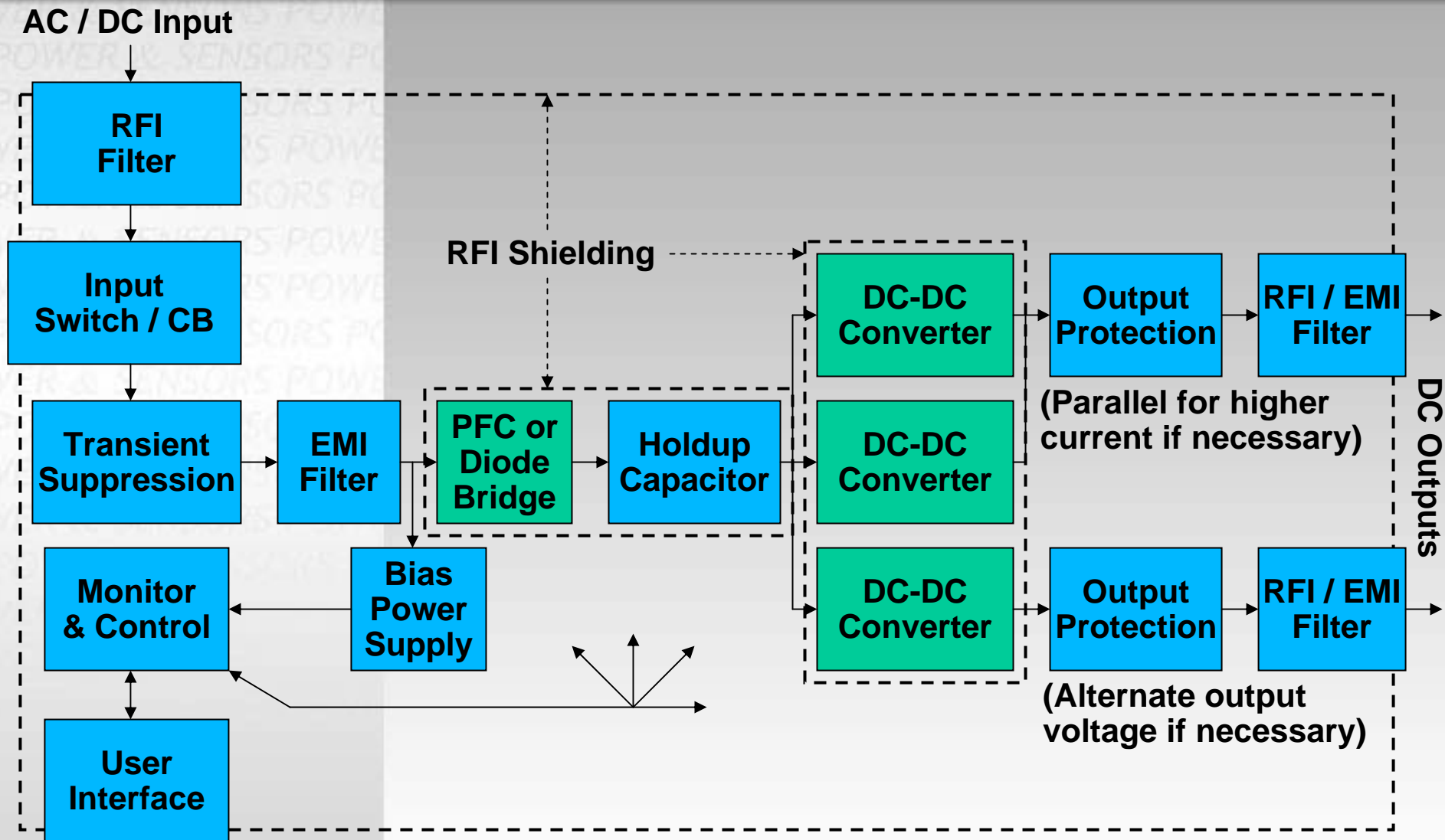

CECOM Tactical Power Supply W15P7T-04-R-C006

- Solicitation:

- “The Army is seeking alternative designs for the cover used to protect the front panel assembly. Currently, the cover is attached to the housing assembly using steel spring pins and hinges. In a tactical environment, these pins break easily.”

- Combining two similar power supplies:

- PP-2953C/U

- PP-6224B/U

into one via MIL-PRF-49080B (CR).

Two Obsolete Power Supplies

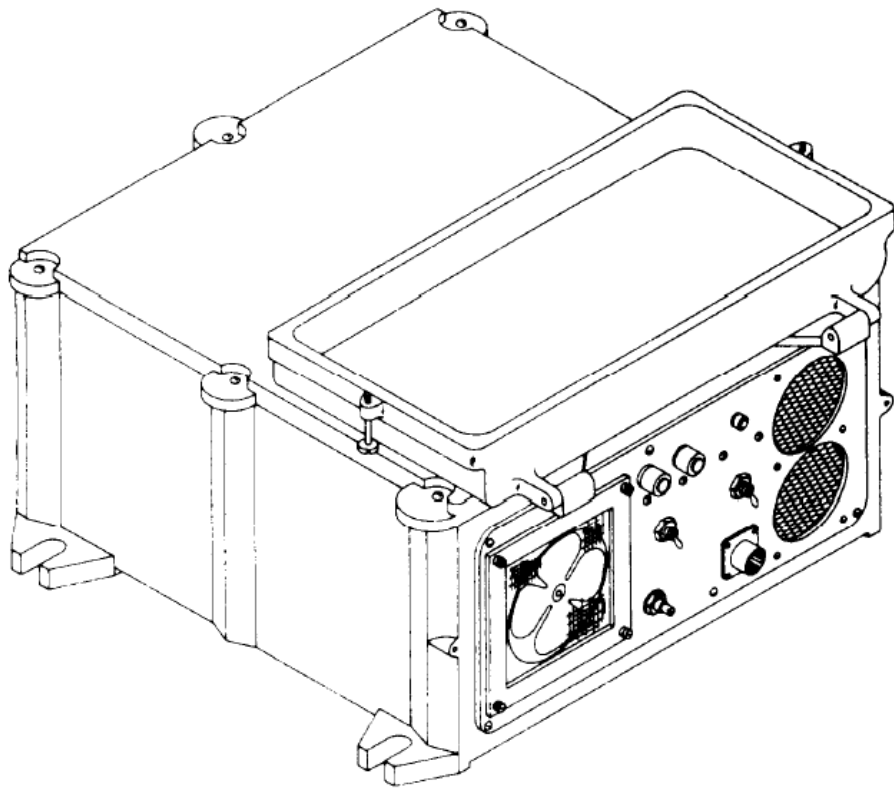

PP-2953C/U

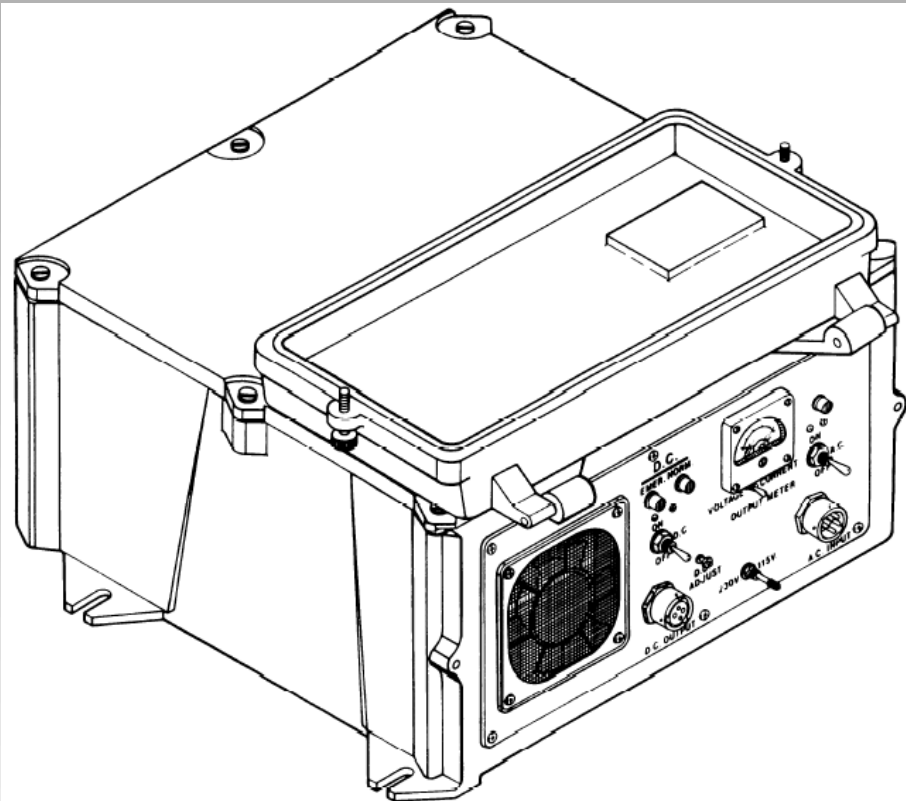

PP-6224B/U

Combined Replacement Power Supply

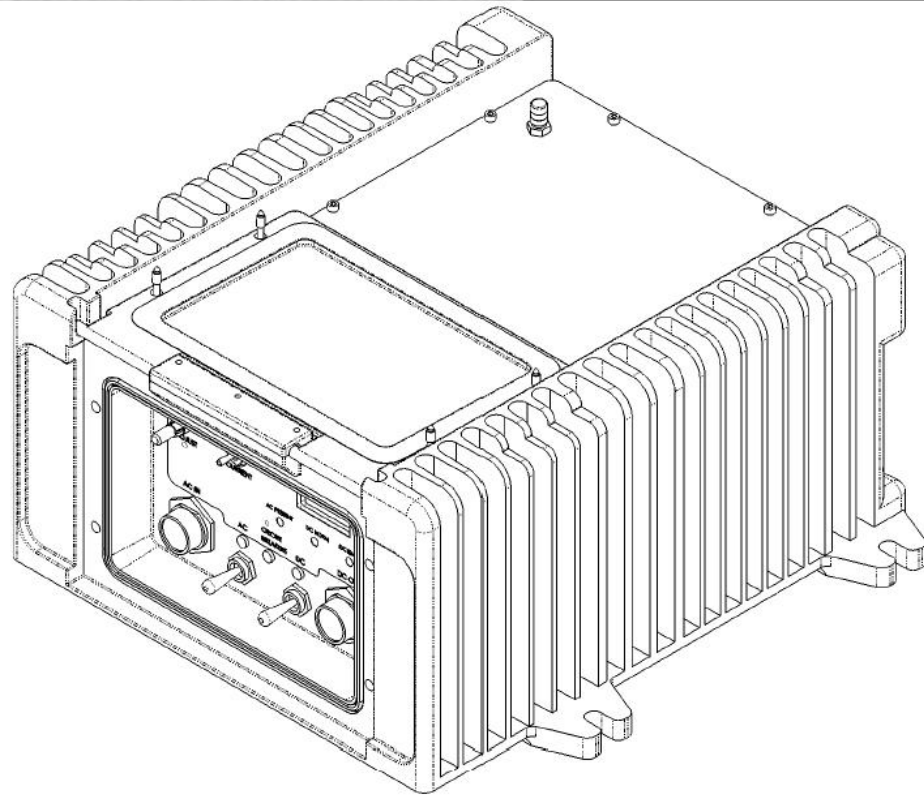

PARAMETER	CHARACTERISTIC
Power Input	115/230 VAC, 50, 60, or 400 Hz, Single Phase (Automatic input power detection)
Power Output	Adjustable 24 – 32 VDC at 0 to 25A (800W)
Standby Mode	24 VDC Battery Standby Mode (pass-through, not DC-to-DC) adjustable from external battery
Output Stability	+/- 1% peak, 0.5% RMS max ripple from 20 Hz to 10 MHz
Temperature Operating Range	Ambient temperatures in the range of 150° F (+66°C) to -40° F (-40°C)
Efficiency	Greater than 70%
Height	7.0 Inches
Width	14.25 Inches
Depth	14.5 Inches
Volume	1446 Inches ³ (0.55W per Inch ³)
Weight	36 Pounds (22W per pound)

PP-2953D/U and PP-6224C/U combined power supply.

Fully interchangeable in form, fit, and function with the previously fielded power supplies.

DC-DC Module

MOSFETs.
Main switch and
common drain for
low conducted
and radiated noise

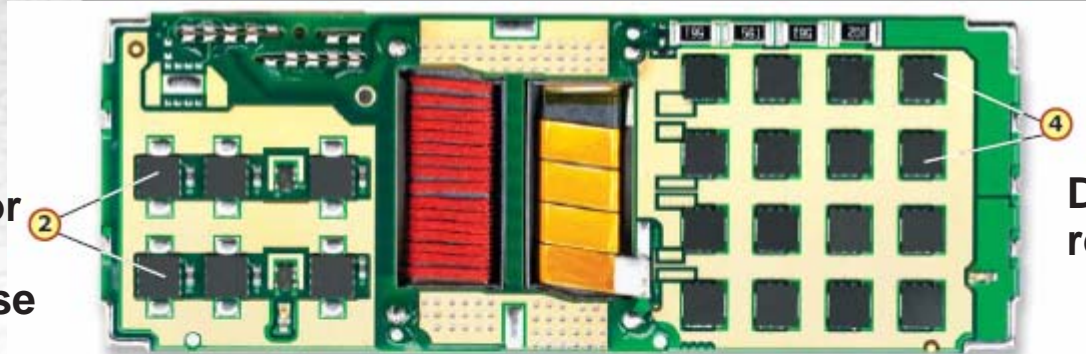

**Dual diode
rectifier**

**Input capacitors
& inductors**

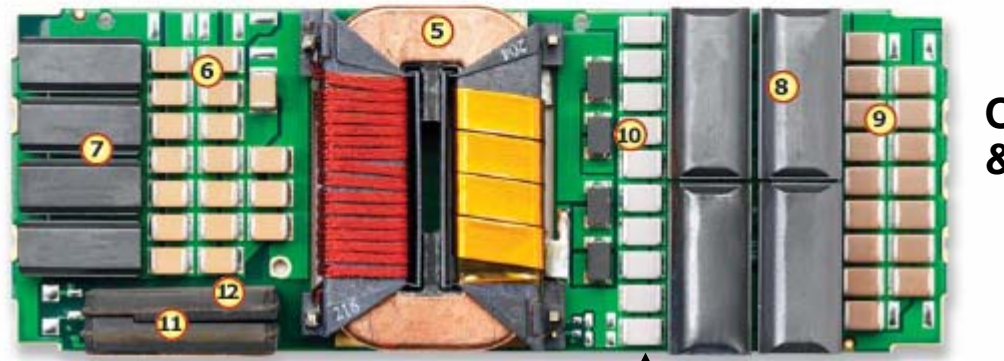

**Output capacitors
& Inductors**

“Brains”.
Primary and secondary
control devices (ASIC)

**Main
Transformer**

Resonant capacitors.
Quasi-resonant tank
for zero-current-
switching converter

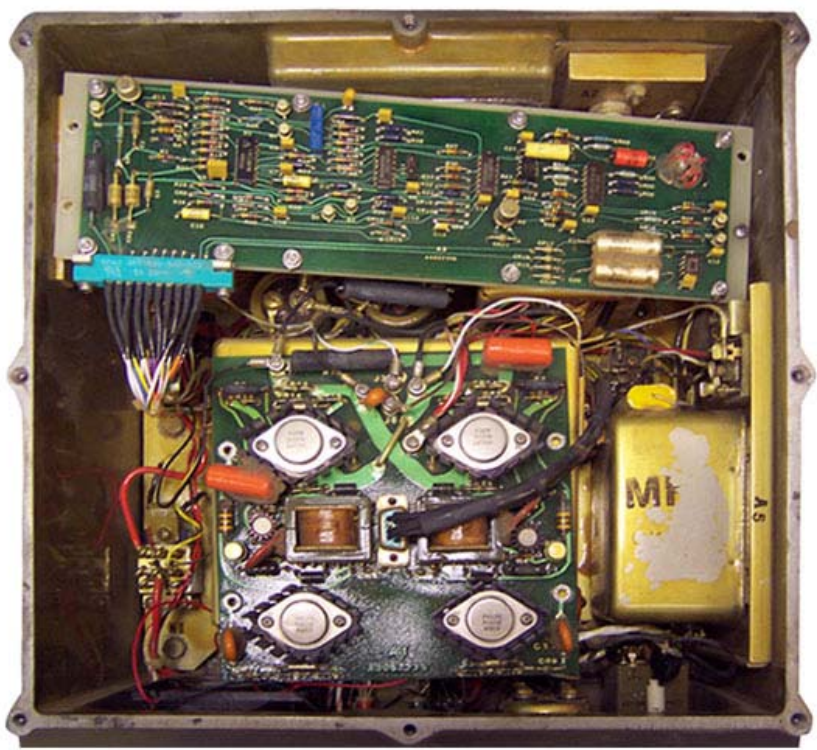

Old

PFC

DC-DC

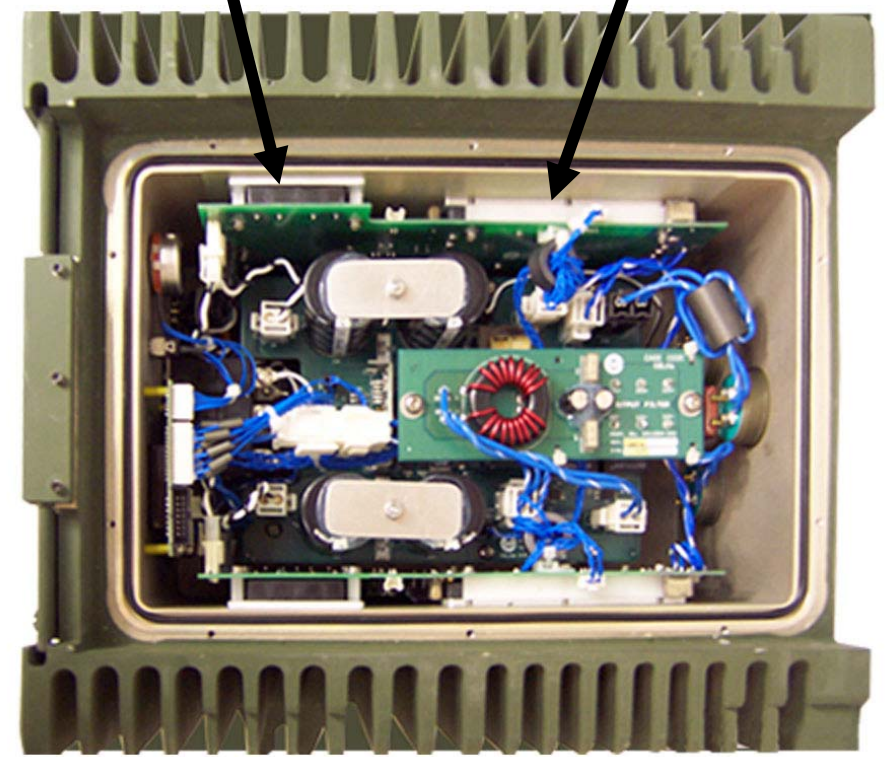

New

Added Features

- Improved cover design:
 - Longer hinge length.
 - Hinge “pin” part of one-part lid.
 - Lid protected from shear when fully open.
- Front panel recessed so items are protected from shear.
- Environmental improvements:
 - Sealed.
 - Old supply used a fan which was another low reliability point.

Note

- Spec did not call for design without a lid, just an “improved” lid. In fact, spec says:
 - “3.3.2.1 Cover. A cover shall be installed to protect the front panel.”
- Front panel elements are mostly sealed:
 - Potentiometer chosen is not sealed due to cost but could have been.
 - LCD/LED cover is thin and sealed unless punctured.

Note

Recessed front panel
+ Totally sealed unit

No need for cover lid at all!

Note

- Lesson:
 - Step back.
 - Look at existing use, possible future use, and possible improvements.
 - Ask.

Added Features

- Auto voltage ranging:
 - 115 VAC +/- 10%
or 230 VAC +/- 10%
 - Can really handle any voltage 85 – 264 VAC, but by spec we had to put in an “undervoltage” changeover to battery bypass for 230 VAC nominal operation.
 - Old supply says: “Applying 230 VAC when switch is in 115 V position will damage Power Supply.”
- Power factor correction
 - Old supply had no PFC.

Added Features

- Overcurrent:
 - 'OC' displayed.
 - Old supply had no indication.
- Battery wiring reversed:
 - '888' displayed.
 - Use of battery is disabled until polarity fixed.
 - Old supply says: "Reverse polarity will cause equipment damage."

Note

- Battery charging:
 - Old power supplies were used for battery charging (foldback current limit then constant voltage for final stage).
 - DC-DC converter technology chosen has current limiting, but does not have foldback current limit, so if the current is high, but not high enough to open the CB, our automatic current limiting circuitry turns off the output for a time and tries again a little later.

Added Features

- Improved efficiency:
 - reduction in the amount of waste heat dissipated per watt of output:
 - permits convection cooling.
- Mechanical design permits stacking 10 high.

Added Features

- Improved reliability:
 - No fan:
 - fan is high failure point.
 - reduces airborne contaminants such as dust and sand.
 - eliminates changing air filters.
 - >90% probability of 5,000 hours failure-free operation.
 - MTBF over 99,000 hours.



PP-2953D/U and PP-6224C/U

Contact Information

Custom Manufacturing & Engineering

2904 44th Ave. N.

St. Petersburg, FL 33714

(727) 547-9799

www.custom-mfg-eng.com

Rich Sidley

Rsidley@custom-mfg-eng.com