



ARMOR HOLDINGS
AEROSPACE & DEFENSE GROUP

ADVANCING SURVIVABILITY



Testing in the Design Phase

Regis Luther

Measuring and Validating Reliability Modeling/Simulation/Validation

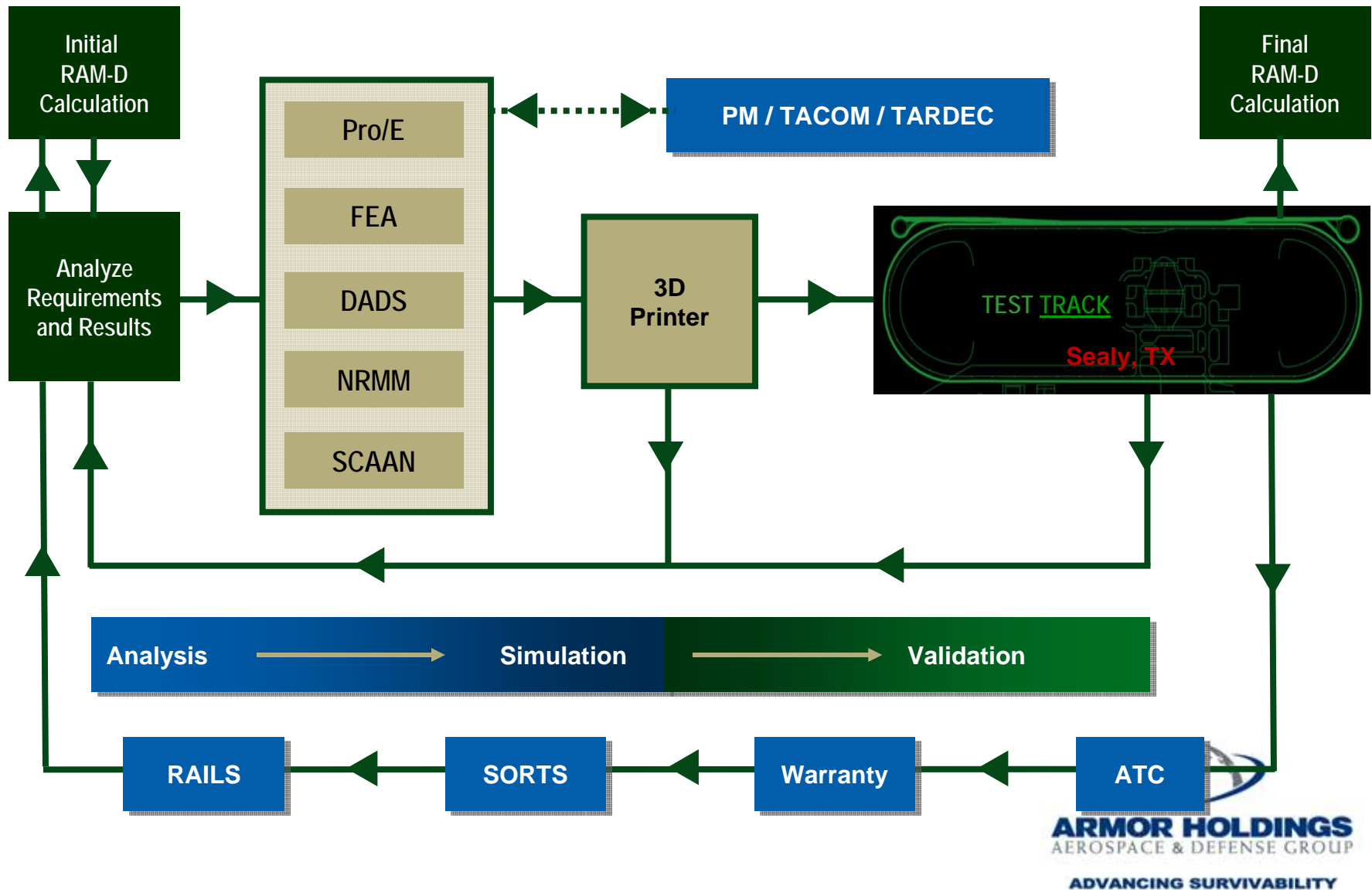

Model Based Definitions

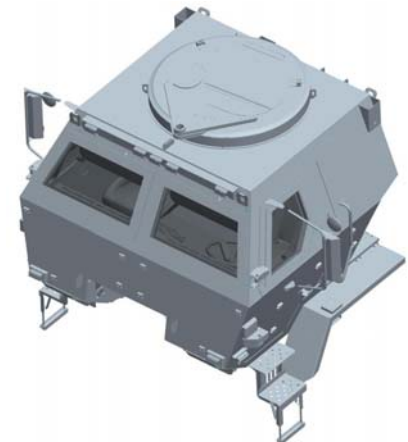
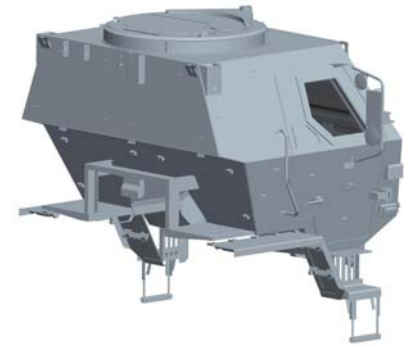
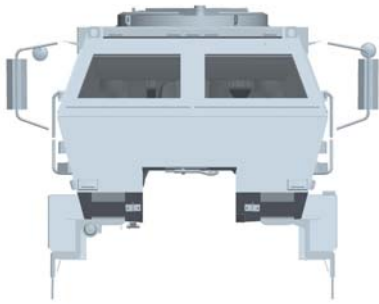

S&S Blast Mine Test



LSAC



ARMOR HOLDINGS
AEROSPACE & DEFENSE GROUP
ADVANCING SURVIVABILITY



- Founded in 1996 - Headquarters in Jacksonville, Florida
- Public Company (NYSE - AH)
 - Market Cap of \$1.898 billion (as of 8/16/06)
- Revenue
 - 2004 Revenue - \$980 million
 - 2005 Revenue - \$1.637 billion
 - 2006 Revenue - \$2.4 billion anticipated
- 6,200 Employees in Three Business Units

	<u>2005 Revenue</u>
- Aerospace & Defense Group (ADG)	\$1,189m
+ <i>Stewart & Stevenson, Pinzgauer</i>	\$ 726m
- Products Group	\$ 309m
- Centigon	\$ 139m

- Manufacturing Operations
 - AL, AZ, CA, FL, KY, MA, MI, NH, OH, PA, TN, TX, WY
 - Brazil, Colombia, France, Germany, Mexico, United Kingdom, Venezuela, Switzerland

AH 2005 Revenue*

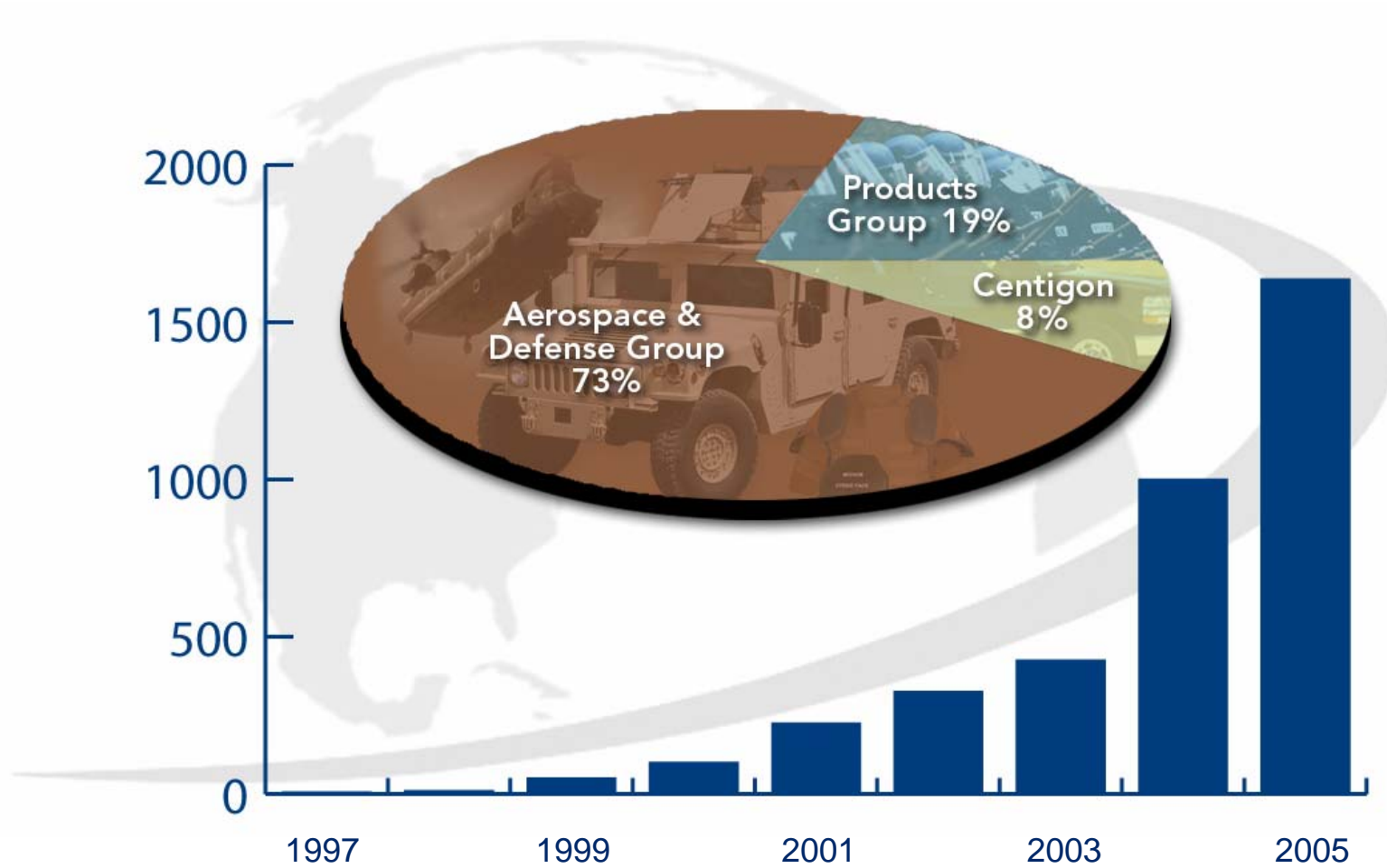

* Exclusive of 2005 Stewart & Stevenson and Pinzgauer revenue of \$726 million



AH Global Reach



★ Aerospace & Defense Group
★ Centigon (Mobile Security)
★ Products Group

Armor Holdings has sold product to all countries in blue



Test Capabilities

- Rolling road and test track facilities
- Complete vehicle testing
- Military Packaging
- Ballistics testing
- Materials testing
- Static testing
- Dynamic testing
- Full-scale impact testing
- Outdoor and indoor drop towers
- Horizontal sled
- High speed photography and video



US Military - FAA - Automotive - Commercial

In-house test capabilities for internal R&D; certified outside labs validate or qualify systems

Copyright © 2006 by Armor Holdings, Inc.

Test Track

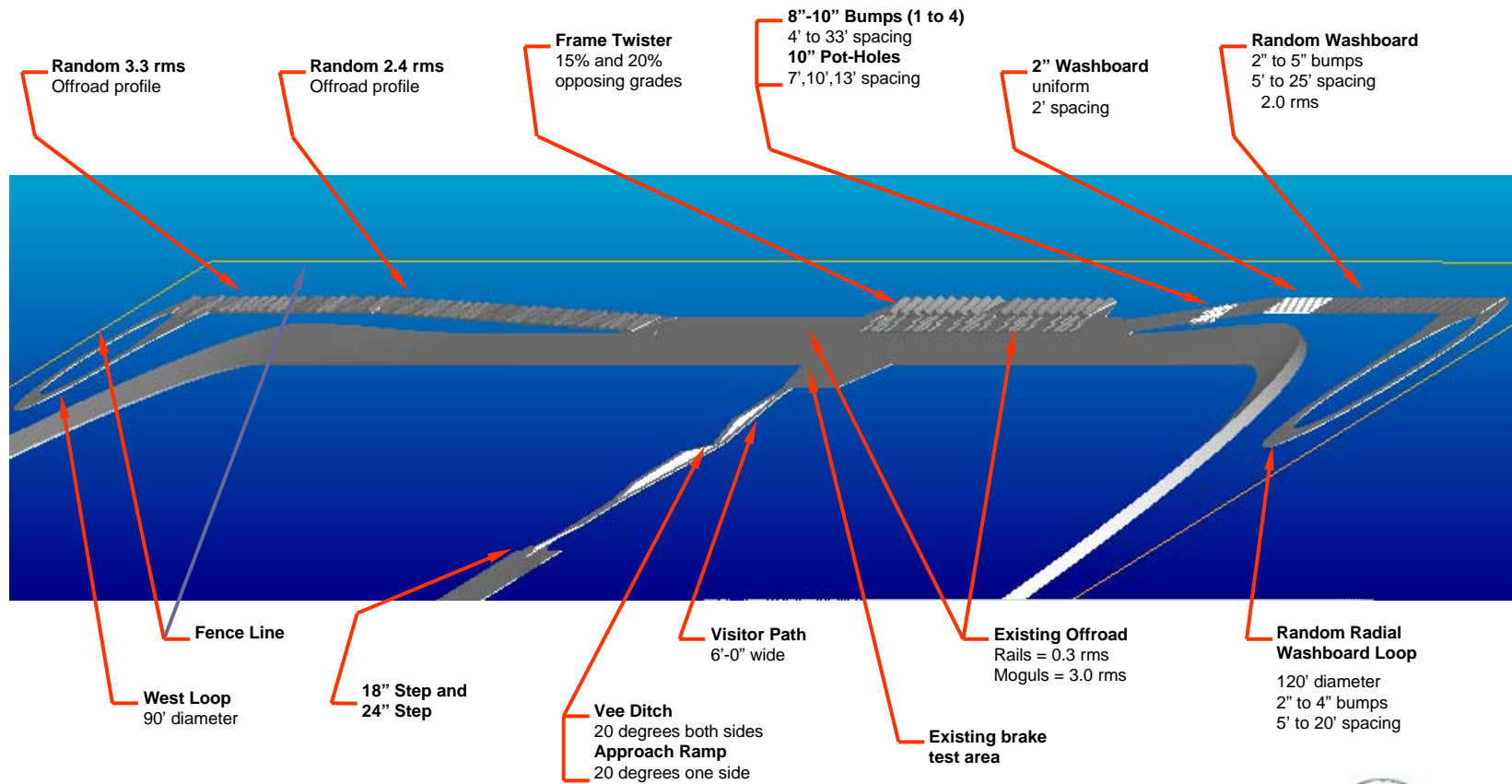

Ultra-Reliability

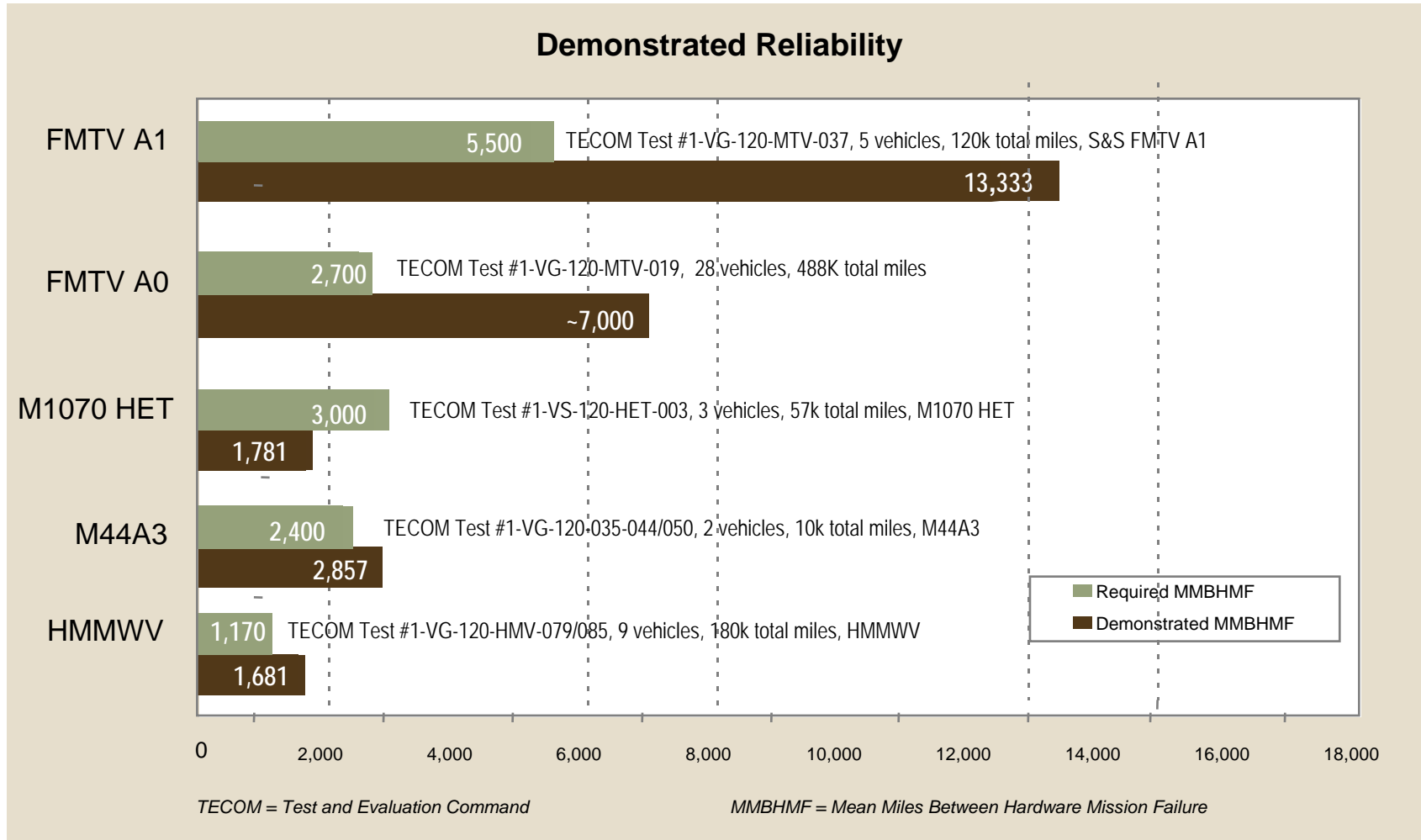

* Fleet average of test vehicles including all failures attributed to CR changes and A1 baseline.



Measuring and Validating Reliability Modeling/Simulation/Validation

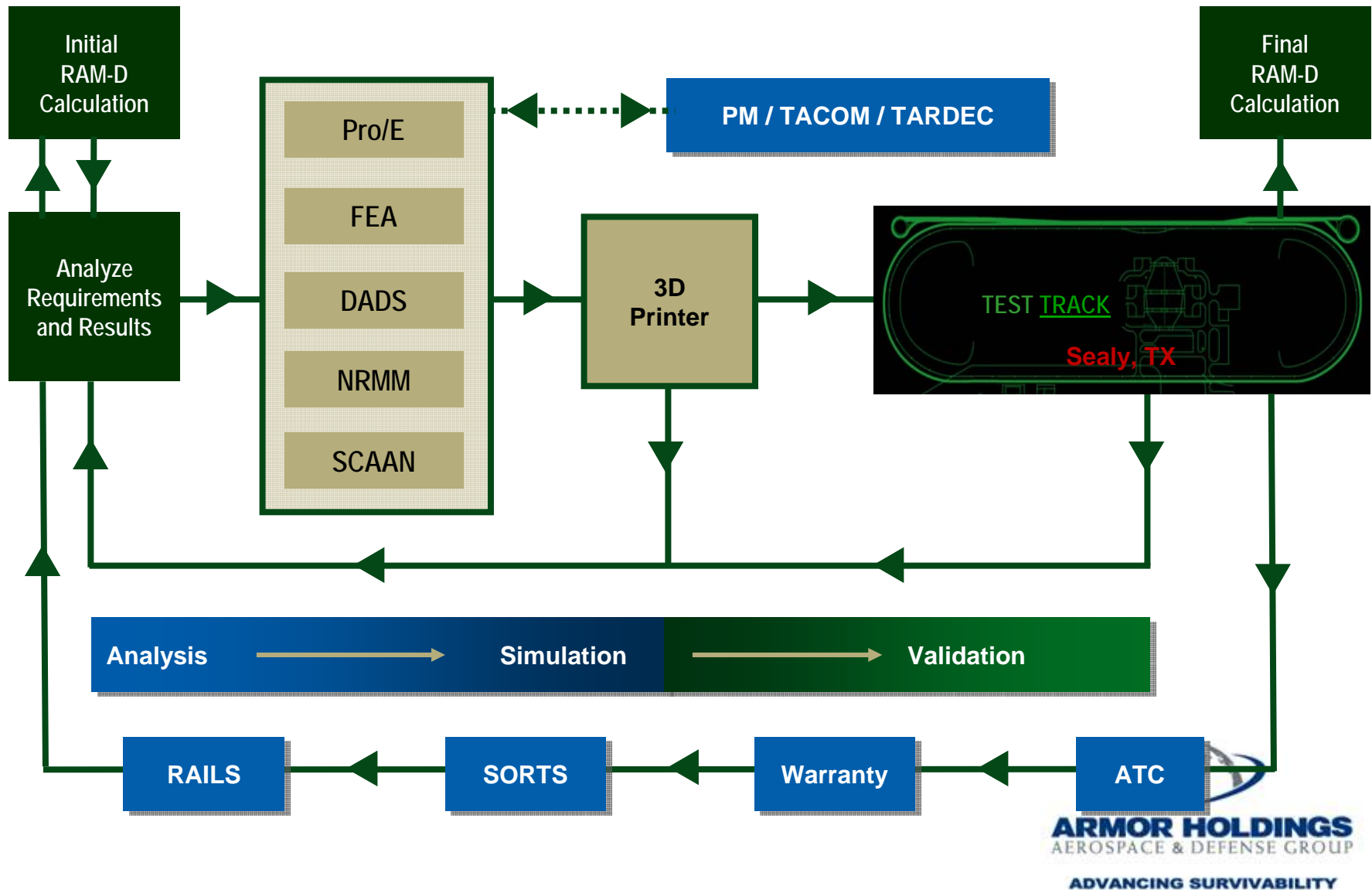

LTAS

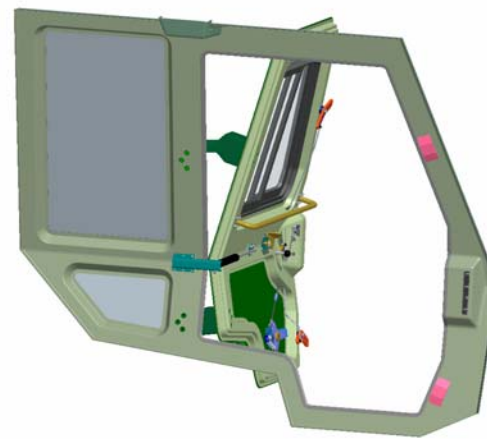

ARMOR HOLDINGS
AEROSPACE & DEFENSE GROUP
ADVANCING SURVIVABILITY



ARMOR HOLDINGS
AEROSPACE & DEFENSE GROUP

Questions