



NASA Dryden Flight Research Center

Robert E. Curry

Department Of Homeland Security
2008 Stakeholders Conference

S&T Partners: Federal Agencies
June 3, 2008
Washington, D.C.



Dryden's Vision: To Fly What Others Only Imagine



Summary of Capabilities



Atmospheric Flight Research and Test Expertise

- Safety and Risk Management
- Project and Mission Management
- Research Technology
- Flight Test Operations

Ground Test Facilities

- Western Aeronautical Test Range
- Research Aircraft Integration Facility
- Simulation Laboratory
- Sensor Integration Laboratories
- Flight Loads Laboratory

Aircraft

- Current Experimental and Testbed Aircraft
 - X-48
 - C-17
 - F-15 (2)
 - F-18 (5)
 - F-16 XL (2)
 - T-34C
 - 747 (2 Shuttle Carriers)
 - T-38 (2)
- Airborne Science Platforms
 - 747 (SOFIA)
 - ER-2 (2)
 - Gulfstream III
 - DC-8
 - Ikhana (Predator B)
 - Global Hawk (2)



On-Going Partnerships

- Other NASA Centers: ARC, GRC, LaRC, JSC, KSC, MSFC
- DoD Partnerships: AFFTC Alliance, USN, AFRL, DARPA
- Other Government Agencies: DOT, NOAA, DHS, ...



Summary of Capabilities

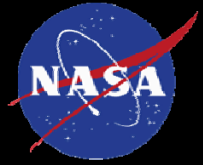

Atmospheric Flight Research and Test Expertise

- Safety and Risk Management
- Project and Mission Management
- Research Technology
- Flight Test Operations

Ground Test Facilities

- Western Aeronautical Test Range
- Research Aircraft Integration Facility
- Simulation Laboratory
- Sensor Integration Laboratories
- Flight Loads Laboratory

Aircraft

- Current Experimental and Testbed Aircraft
 - X-48
 - C-17
 - F-15 (2)
 - F-18 (5)
 - F-16 XL (2)
 - T-34C
 - 747 (2 Shuttle Carriers)
 - T-38 (2)
- Airborne Science Platforms
 - 747 (SOFA)
 - ER-2 (2)
 - DC-8
 - Gulfstream III
 - Ikhana (Predator B)
 - Global Hawk (2)

Focus of this presentation



On-Going Partnerships

- Other NASA Centers: ARC, GRC, LaRC, JSC, KSC, MSFC
- DoD Partnerships: AFFTC Alliance, USN, AFRL, DARPA
- Other Government Agencies: DOT, NOAA, DHS, ...





ER-2

Very High Altitude, Long Range and Endurance

Capabilities

- Ceiling > 70,000 ft
- Duration > 10 hours
- Range > 4,000 nautical miles
- Payload 2,600 lbs
(700 lbs in each wing pod)

Mission Support Features

- Multiple locations for payload instruments
- Pressurized and un-pressurized compartments
- Standardized cockpit control panel for activation and control of payload instruments
- World-wide deployment experience



Background and Status

- U-2 and ER-2 aircraft have been a mainstay of NASA airborne sciences since 1971
- Over 100 science instruments integrated
- Two aircraft



ER-2 Participation in CHLOE White Sands Demonstrations



Full azimuth coverage
with 6 IR, non-cryogenic
photodiode arrays

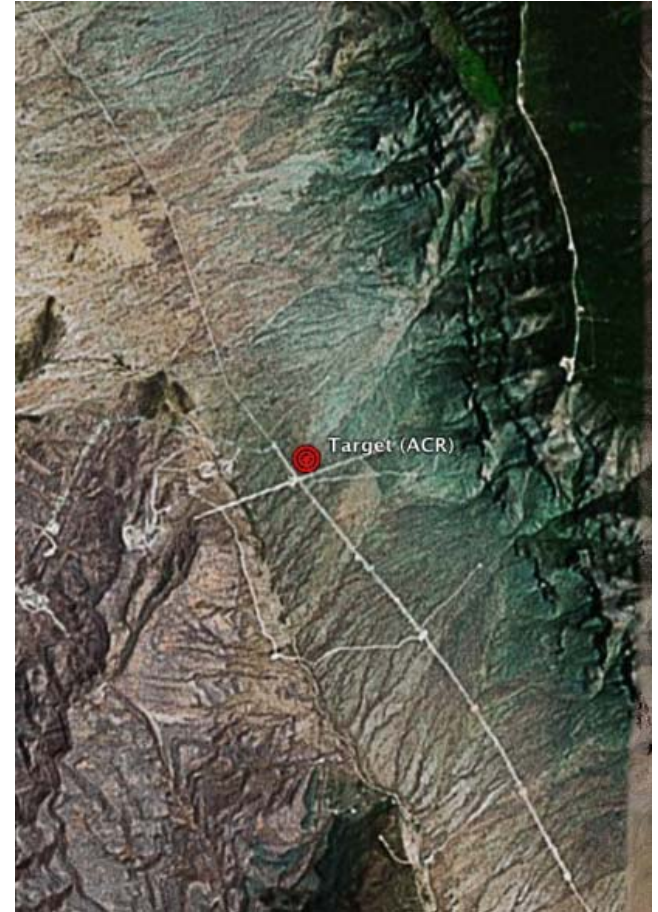
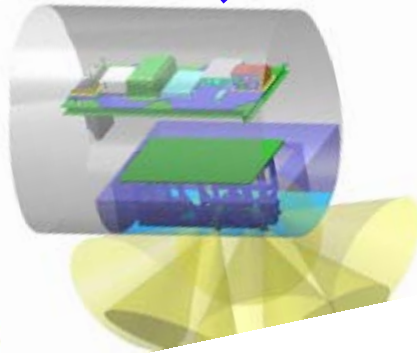

- Demonstration of Naval Research Labs Missile Warning System
- Emulated role of unmanned high altitude platform
- Rapid response capitalized on test opportunity => planning, sensor integration, check-out and deployment within 3 months



DC-8 Flying Laboratory

Large Capacity, Range and Endurance

Capabilities

- Ceiling 42,000 ft.
- Duration 12 hours
- Range > 5,400 nautical miles
- Payload 30,000 lbs

Mission Support Features

- Shirtsleeve environment for up to 30 researchers
- worldwide deployment experience
- Extensive modifications to support in-situ and remote sensing instruments
 - zenith and nadir viewports
 - wing pylons
 - modified power systems
 - 19 inch rack mounting



Gulfstream III and the UAVSAR

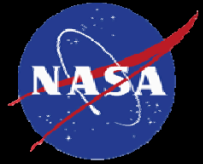

- **UAVSAR**

- Mission: to provide new capability for solid earth science
 - Airborne repeat-pass radar imaging
 - Interferometric mapping of deforming surface
- Description
 - Pod mounted instrument.
 - Compatible with the G-III or the Global Hawk
 - Global Hawk is programmed to carry two UAVSARS in the future.



- **Gulfstream III**

- Able to carry pod mounted instruments.
 - Using modified Mk 12 attach points
- < 10 m tube flight path using JPL real-time DGPS and Dryden Platform Precision Autopilot
- Endurance: 6 hours
- Ceiling: 45,000ft

- **Availability**

- The UAVSAR/G-III combination will be considered operational this fall.
- Good schedule availability.

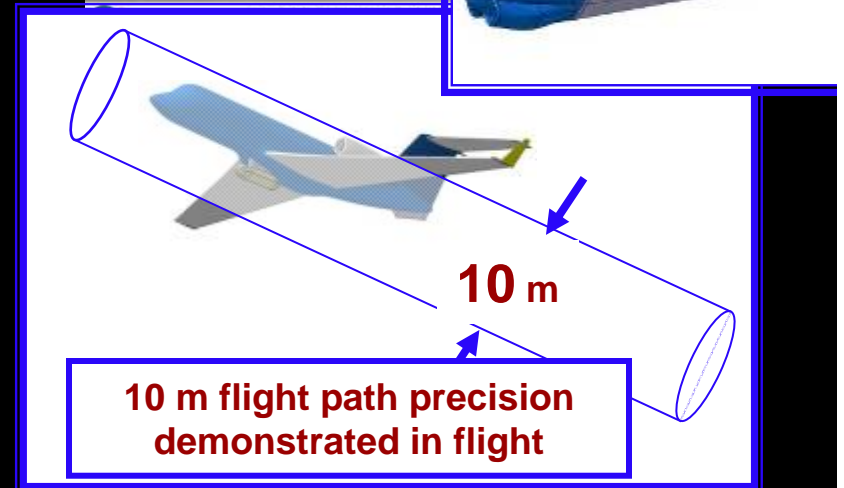



Ikhana

Medium Altitude, Very Long Endurance

Capabilities

- Duration > 24 hours
- Ceiling > 40,000 ft
- Payload 2,000 lbs, 750 lbs in wing pod
- Highly reliable UAS

Mission Support Features

- Deployment ready
 - Mobile ground station
 - High bandwidth science data link
 - Transport by land/sea/air
 - Ku Satcom for over the horizon missions
- External experiment pod with payload tray for parallel mission processing
- Internal payload compartments
- Experimenter network and data system
- Airborne Research Test System



Ikhana Western States Fire Missions 2007

1st Fire Mission 8/16/07
9.5 hours
1400 nmi

2nd Fire Mission 8/29/07
16.1 hours
2500 nmi

3rd Fire Mission 9/7/07
20 hours
3200 nmi

4th Fire Mission 9/27/07
10 hours
1800 nmi

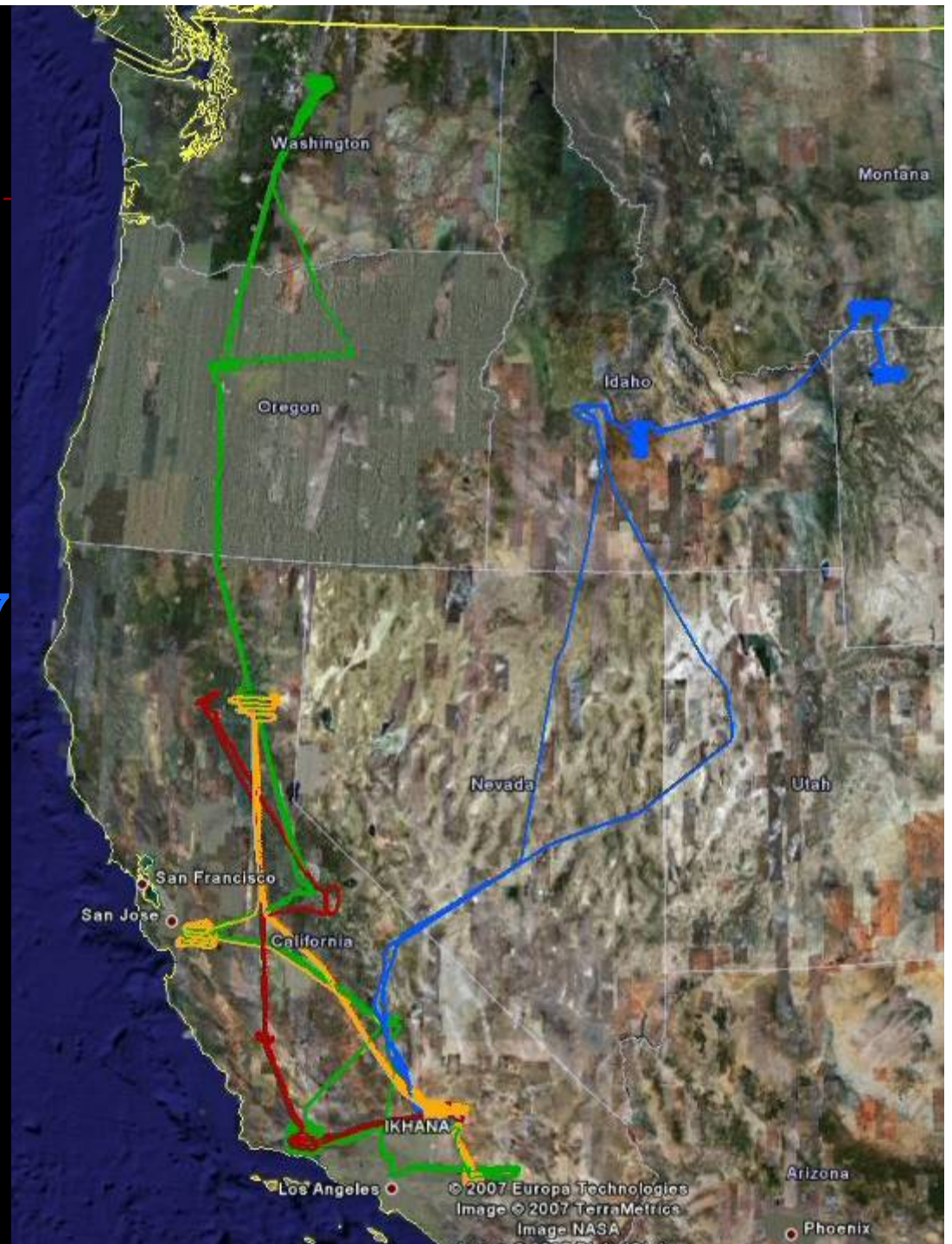

SoCal Emergency Response Missions With Ikhana in the Fall of 2007

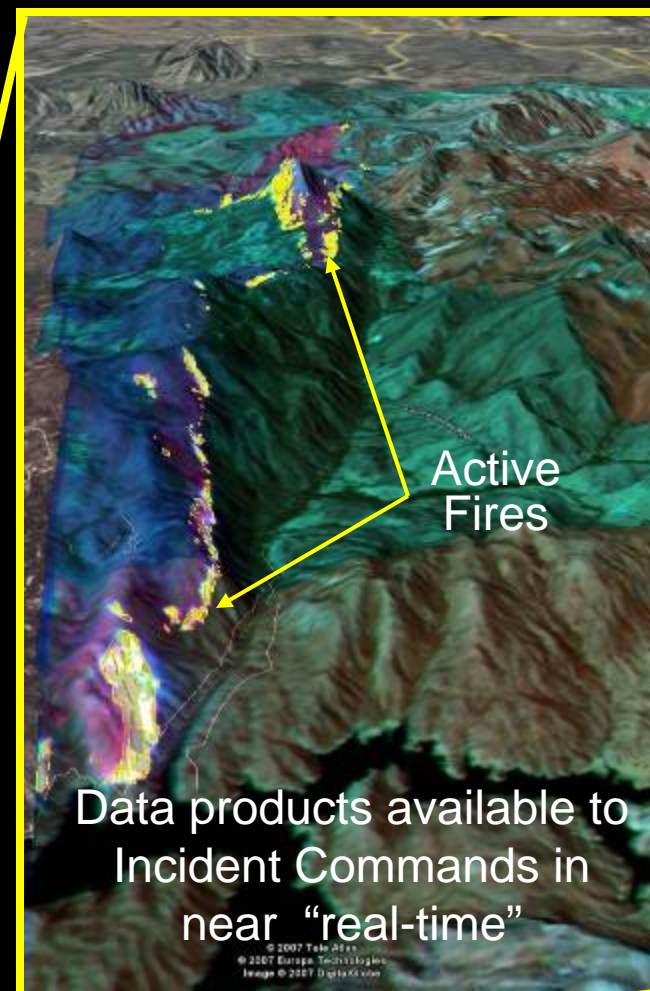
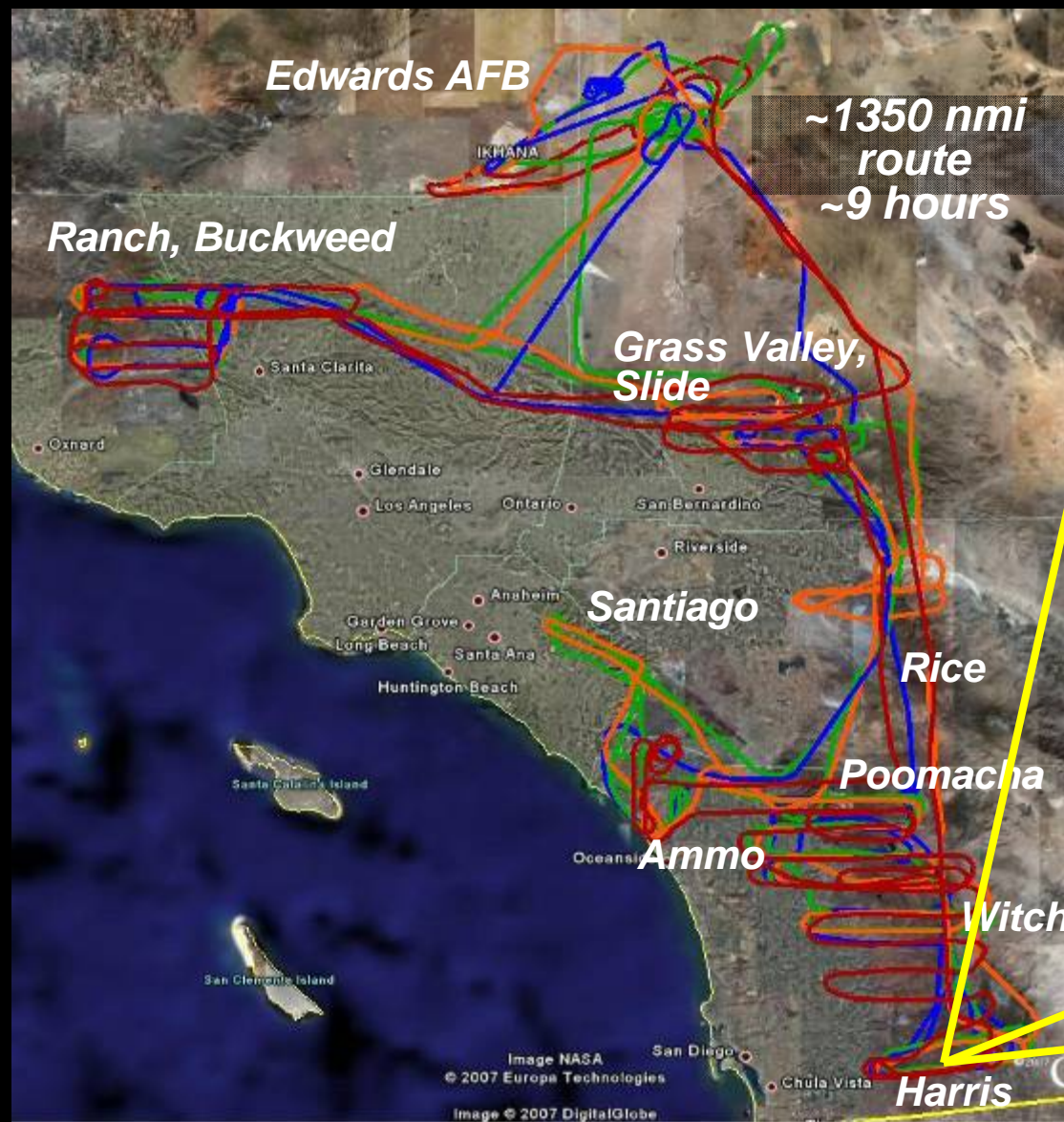

Global Hawk

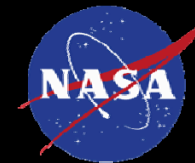

■ **Capabilities**

- Endurance > 30 hours
- Range > 11,000 nmi
- Altitude 65,000 ft
- Payload > 1,500 lbs
- DC Power 2.0 KW
- AC Power 8.3 KVA

■ IOC for AV-6: Spring '09

■ IOC for AV-1: Summer '09

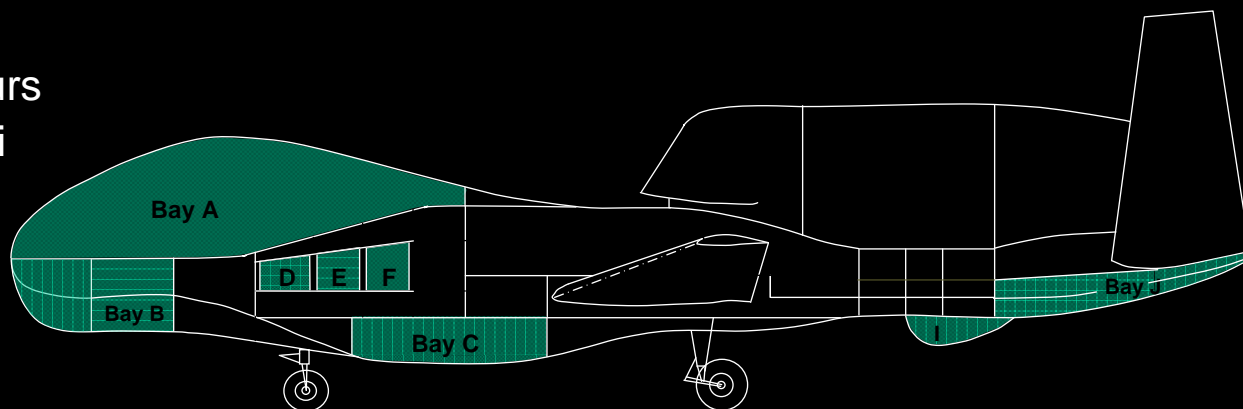

■ **Mission Support Features**

- Multiple payload locations.
 - Pressurized and un-pressurized.
 - Can accommodate wing pods (future).
- REVEAL system with ethernet network on the aircraft for payload control and status.
- Fully autonomous aircraft control system, take-off to landing.
- Redundant LOS and BLOS aircraft command and control comm links.
- Redundant BLOS ATC comm links.

Global Hawk Operational Capability

Four Mission Regions, with Arcs of Constant On-Station Times

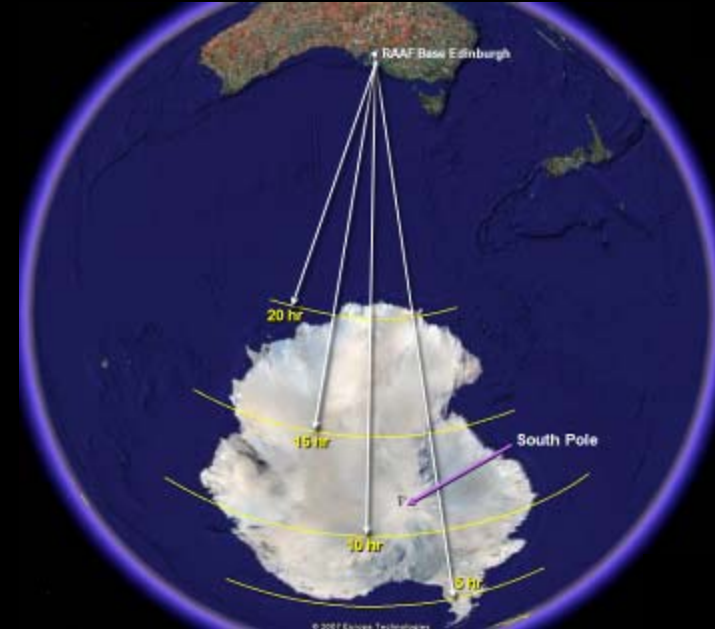

Summary



- *NASA Dryden can provide unique flight capabilities through partnership activities that serve the national interest*
- *Past experiences have demonstrated the benefits of collaboration*



Questions?

