

# The Role of T&E in the Requirements Process for System of Systems



Walter C. Reel  
Test Engineer  
NSWCDD - W33  
walter.reel@navy.mil

<http://www.ctc.com/learnaboutctc/SoSCE.cfm>

# The Problem



Charlie Chaplin in "Modern Times"

How do we define testable requirements for System of Systems (SoS) when no one understands *exactly* how the complex system will operate and integrate once it comes on-line and the human in the loop is added to the equation?

# The Problem



Most problems with SoS designs, (as with most designs), lead us back to the requirements phase.

The synthesis of these very large systems often results in different problems than those presented by the design of a single, but complex, system.

# Historical Approach

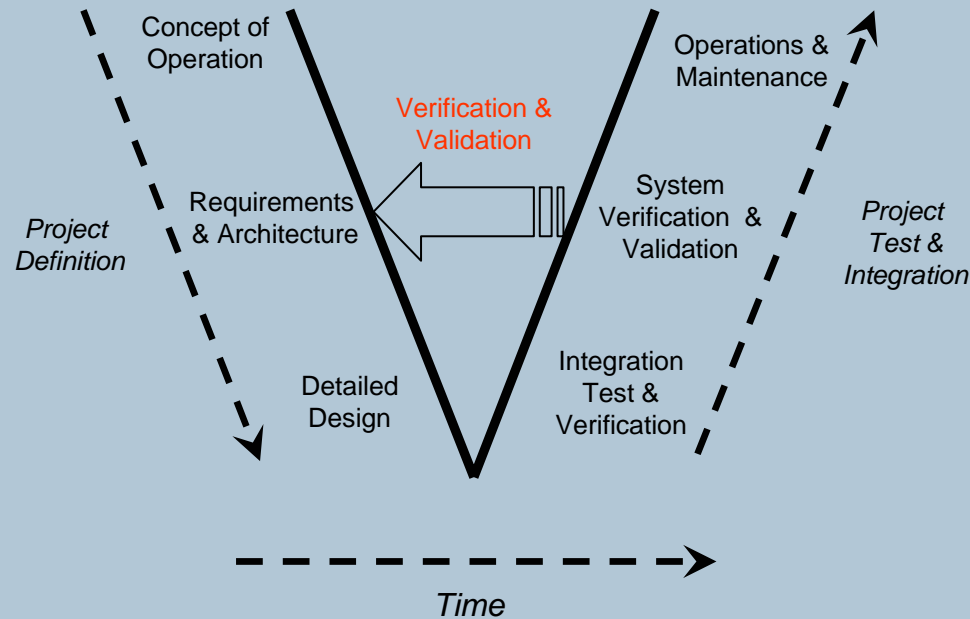

In the past the contribution of Test and Evaluation professionals has not come until after the system Detailed Design phase.

It is our recommendation that this be changed and T&E personnel be involved from the beginning of the Requirements and Architecture phase.

# The Problem Continued



What do we want the SoS to be able to do?

This is often a very complex question that can have multiple and vague answers that have little meaning when it comes to defining measurable metrics for later testing of our system.

We usually end up with requirements that are too detailed and “Pie in the Sky” requirements that are too vague to implement.

“The system CPU will operate at 500 megahertz.”

“The system will create synergy among multiple sensor systems and enable data fusion at all levels.”

# End User Example



## Primitive Need Statement for C2 Cell of a C4ISR System

“I need to be able to visualize what my Intel guys are collecting and analyzing so that my understanding of the battle area is current and my decisions are based on accurate, comprehensive, up to date information. I also need to have an understanding of what is changing now, how long things can be expected to remain the same (Dwell Time) and the status of the enemy’s assets as well as my own, and I need this to be a simple process.”



# End User Example

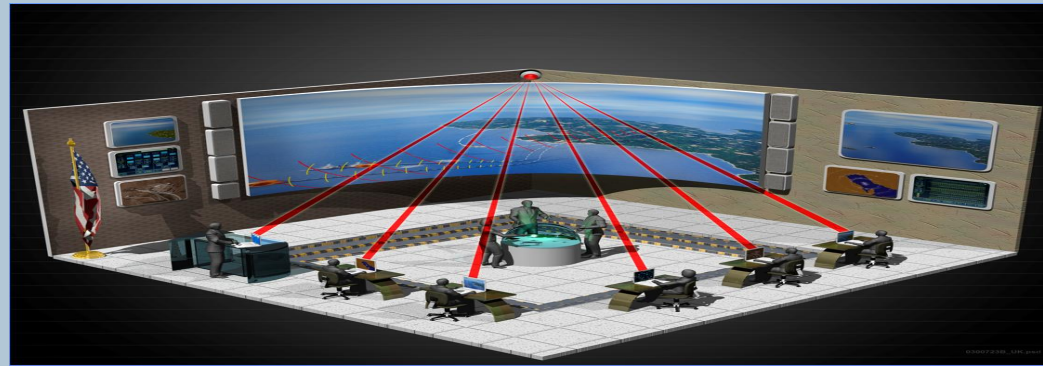

<http://www.optemax.com/html/productmilindoor.html>

Seems to be a reasonable request, right?

Well let's look at this primitive need statement and try to do a quick and dirty breakdown of what functionality the Commander is looking for us to incorporate into our C4ISR system to provide these required Command and Control capabilities.

- *Situational Awareness:*

- Visualization of the Battlespace
- Near/Real Time Information
- Sensor Availability
- Data Fusion
- Predictive Intelligence
- Blue Force Intel
- Order of Battle (OOB)
- Advanced HSI

# End User Example

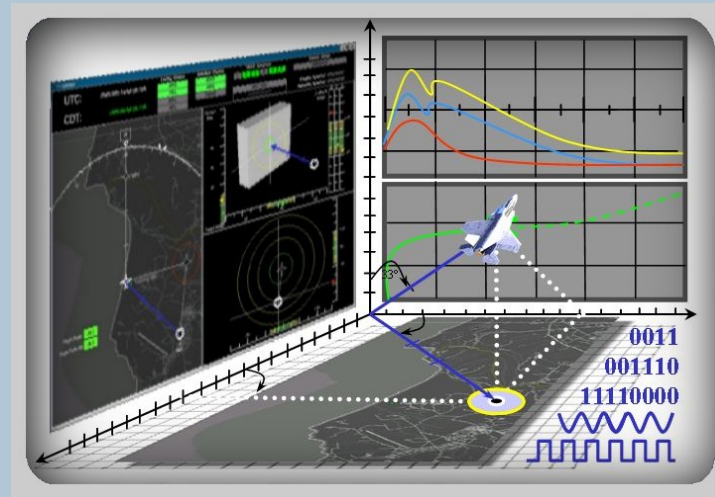

<http://www.cctcorp.com/>

Now let's break down each of these major functionalities into some of their supporting functions.

- Visualization:

- Maps
- Overlays
- Terrain information
- Weather Information
- Symbology
- Movement Representation (Vector)
- Detail Drill Down
- Information Filtering and Manipulation
- DATA Handling



# End User Example



[http://blog.businessquests.com/marketing\\_marketing\\_x0/index.html](http://blog.businessquests.com/marketing_marketing_x0/index.html)

- Near/Real Time Information:

- Direct Sensor feed
- Single Step Data Sharing
- Prioritization of Information
- Latency of Information

# End User Example

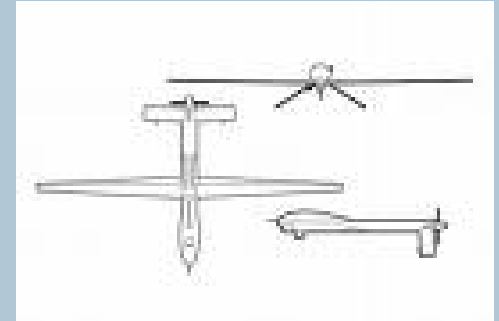

- Sensor Availability:

- Multiple Sensors
- On Station Time
- Full Spectrum of Sensor Types
- Local Sensor Tasking
- Live Sensor Data Feeds
- Information on Data Accuracy/Latency

# End User Example



- Data Fusion:
  - Autonomous Data Fusion
  - Selectable Data Fusion
  - Fusion C2 Products
  - Fusion C2 Symbology
  - Information Reliability Ratings

# End User Example



- Predictive Intelligence:
  - Dwell Time
  - Probable Destination for Moving Units
  - Probable Unit Strength
  - Probable Unit Type
  - Probable Unit Action
  - Predicted Unit Weaknesses
  - Information Reliability Ratings

# End User Example

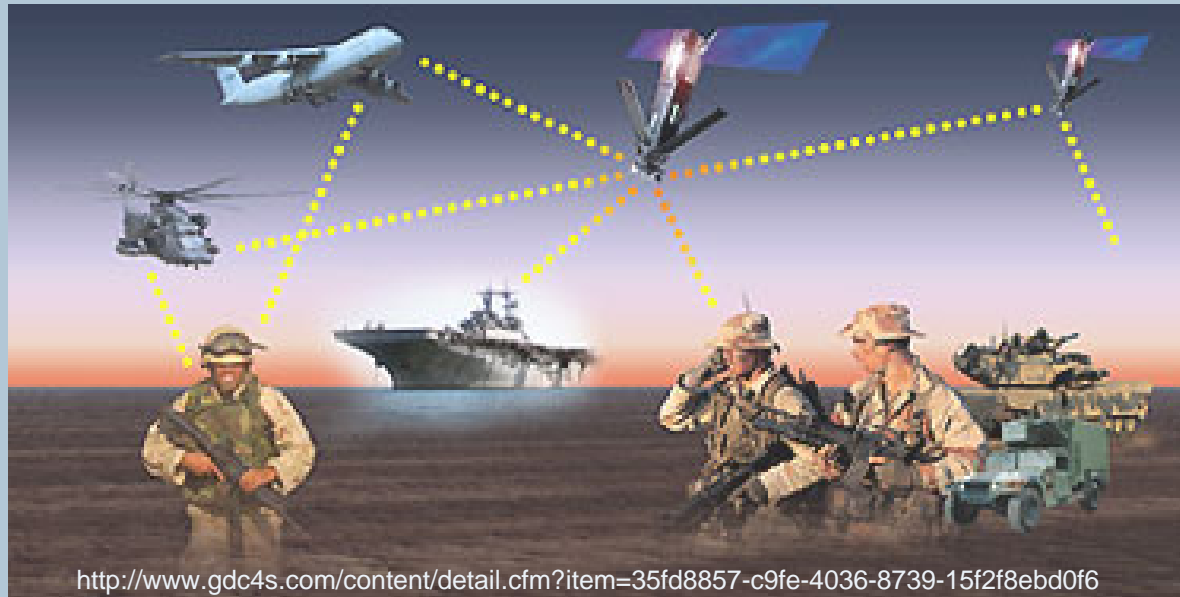

- Blue Force Intel:
  - Unit Location
  - Unit Movement
  - Unit SITREP
  - Latency of Information

# End User Example

## 航空団の組織

航空団の組織は、一般的に次のようになっています。

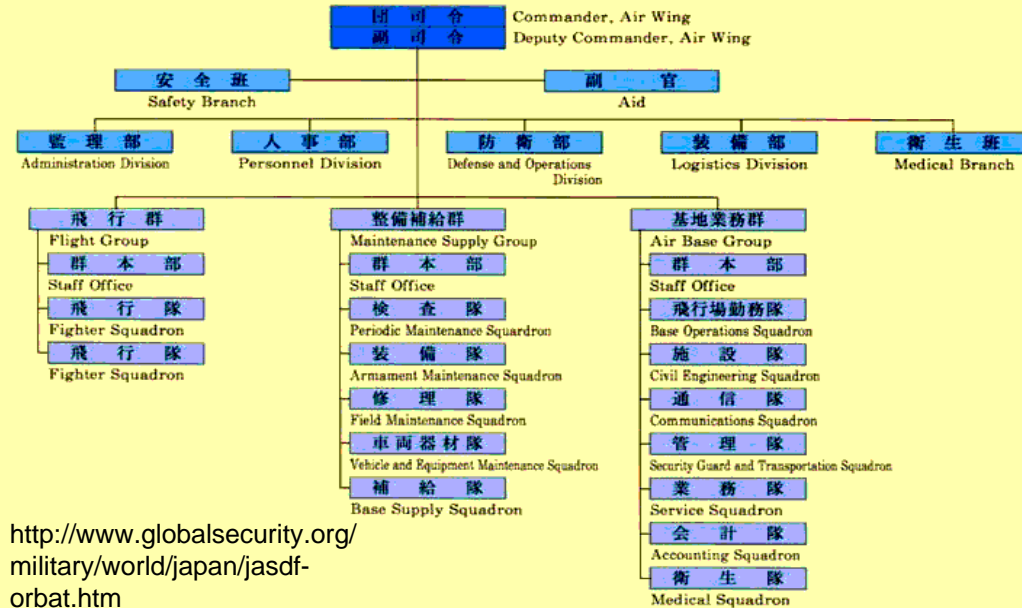

<http://www.globalsecurity.org/military/world/japan/jasdf-orbat.htm>

### •OOB:

- Known Enemy Unit Locations
- Known Enemy Unit Equipment
- Known Enemy Unit Strength
- Known Enemy Unit Weaknesses
- Known Enemy Unit Range and Speed
- Latency and reliability of Information



# End User Example

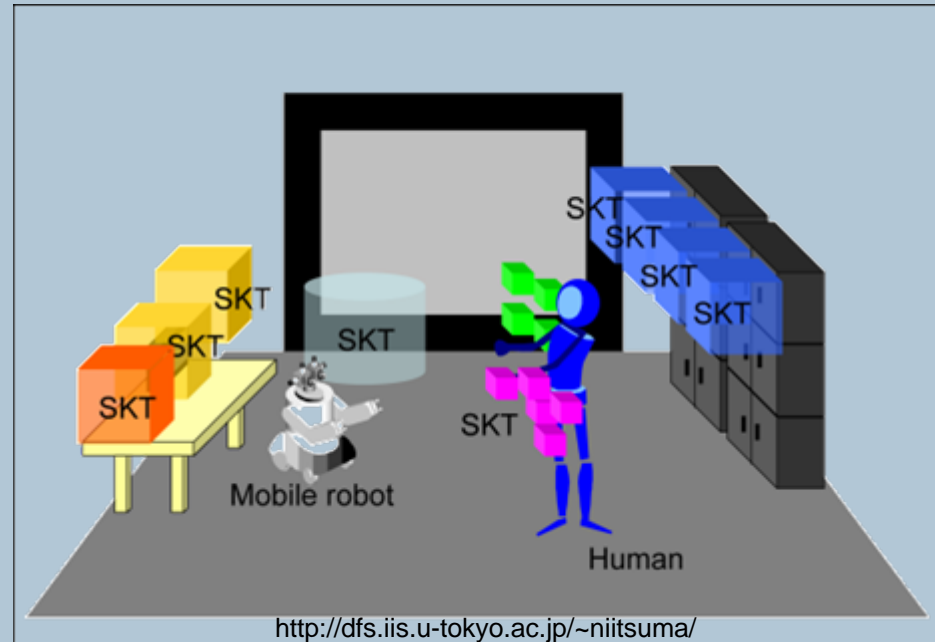

- Advanced HSI:

- Operators Control Visual Clutter
- Simple HSI Actions for Data Manipulation, Retrieval, and Storage

We can readily see that many systems will be involved in providing these capabilities to the Command and Control Cell to meet the user's needs.

# End User Example

## Generate an Effective Need Statement

“A Command and Control System is required that integrates Near/Real Time Information from Enemy OOB, all deployed Sensors, ISR Data Fusion, Intelligence Analysis, Predictive Intelligence, Blue Force Intel, enemy unit location, and all unit movement data. The system will allow Visualization of this information within the defined Battlespace and allow the operator to manipulate and request information updates and details utilizing simple HSI functionality. The system will be able to filter, store, and transfer information for detailed scrutiny to limit visual clutter.”

# What's Next

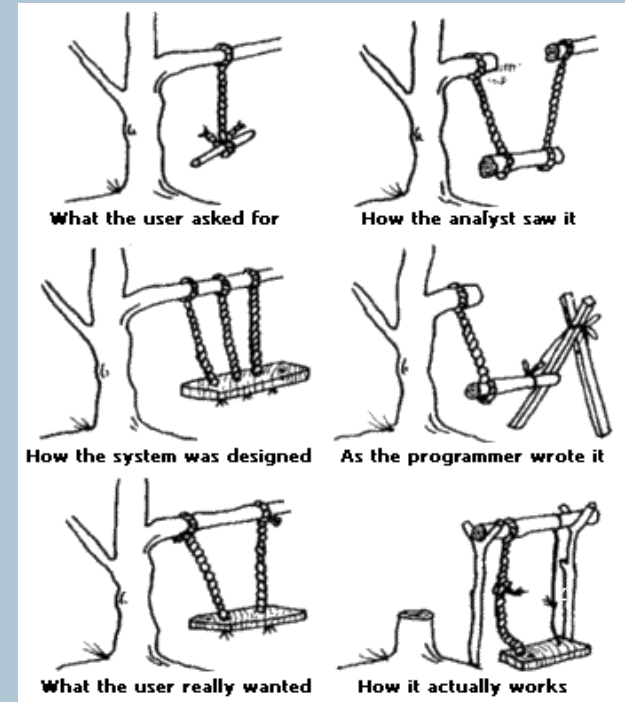
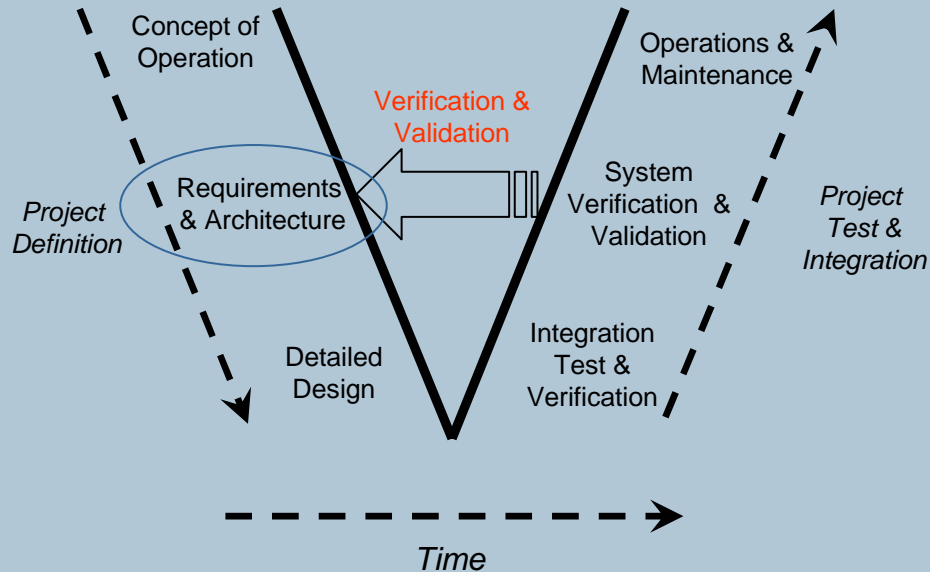

The Requirements Definition process now becomes our primary mission

This process should be conducted utilizing the Integrated Product Team approach and should include all Stakeholders.

If the requirements are too vague System Design will suffer as will construction, test and evaluation.

If the requirements are too specific the ability of the contractor to build a better mousetrap will be hindered and system functionality may suffer

# Requirements Generation



What approach will ensure that the requirements are written so that they properly support the user's needs and also provide design and testing adequate information to do their job?

Requirements should be written and then evaluated and then re-written and then re-evaluated and then re-written and re-evaluated, etc..., until a consensus is reached by ALL Stakeholders.

We are reminded of the old carpenter's adage, "measure twice and cut once."



# Collaborating System Interactions



In a SoS world, requirements may already be established for the systems that you will integrate with.

This can often require great negotiating skills, if you are the new kid on the block it is very likely that you will have to make most of the concessions if there are issues with interfacing with fielded systems.

# Requirements Generation



Here we see an inherent problem with SoS design and Acquisition:

If we have to incorporate or modify existing systems in order to achieve the desired functionality to fill the user's need our process will become more time and coordination intensive.

This fact has driven the requirements for Net-Centric Design and Service Oriented Architecture that could ease the integration of multiple Inter/Intra-network systems into a SoS framework



# Requirements Generation



Let's get back to our discussion and look at Information Exchange Requirements (IERs). In a SoS acquisition IERs become much more important than in most system designs.

IERs tell us who exchanges what information with whom, why the information is necessary, how the information is used, and defines the metrics for the IER.

In SoS there may be hundreds of IERs and to imagine having the resources to test and evaluate all of them is unrealistic. Just as we cannot possibly test all possible combinations of inputs and pre-conditions in a complex software program we will not be able to test all IERs in a complex SoS. Therefore, as with software, we must evaluate the SoS's states and behaviors against a specification.

# Requirements Generation

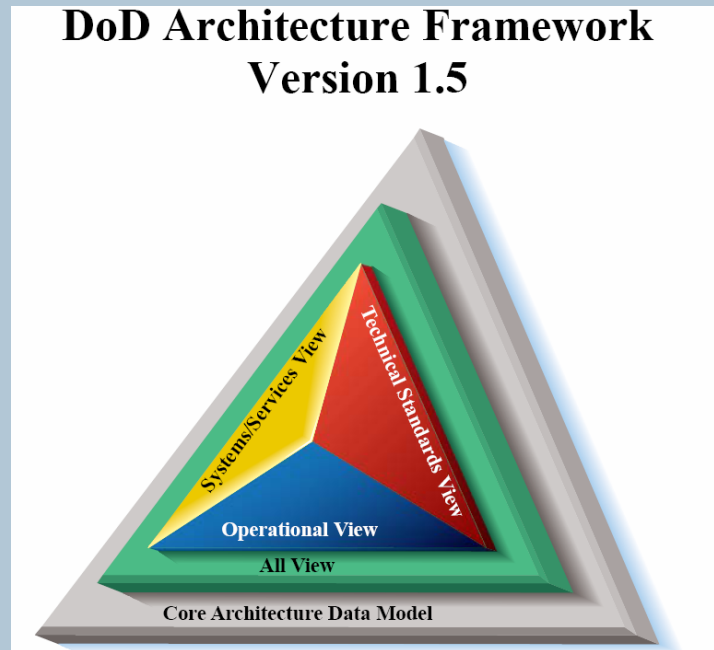

A key tool for the definition of how a System of Systems will interface, who it will interface with and what data will be exchanged and the rules for exchanging information among systems is the Department of Defense Architectural Framework (DODAF). The major product areas are defined in the figure above.

Input in the generation of these documents by Test and Evaluation personnel would help to insure that they can be realistically tested and also provide T&E experience to the sponsor during the early generation of system capability definition.

# The Role of Test and Evaluation



T&E personnel must be involved from the beginning of the Requirements Definition Phase

Test personnel will be responsible for designing the developmental and operational testing of the system and need to have input into whether or not the requirements being generated can be tested.

# The Role of Test and Evaluation

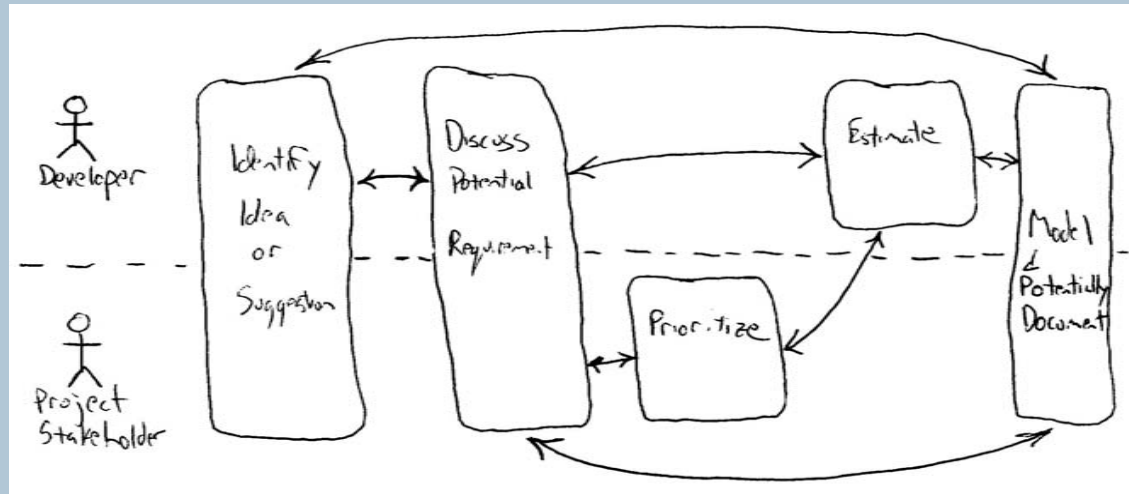

<http://www.agilemodeling.com/essays/agileRequirementsBestPractices.htm>

Requirements come from many sources;

Sponsors put them in the Acquisition Capabilities documents when defining for the acquisition Program Manager their Key Performance Parameters (KPPs) and other attributes.

Requirements may be determined by the Joint Chiefs of Staff (JCS) as overarching requirements for all programs.

Requirements are derived from discussion with stakeholders and users and they evolve from the process of defining the required system performance.

# The Role of Test and Evaluation

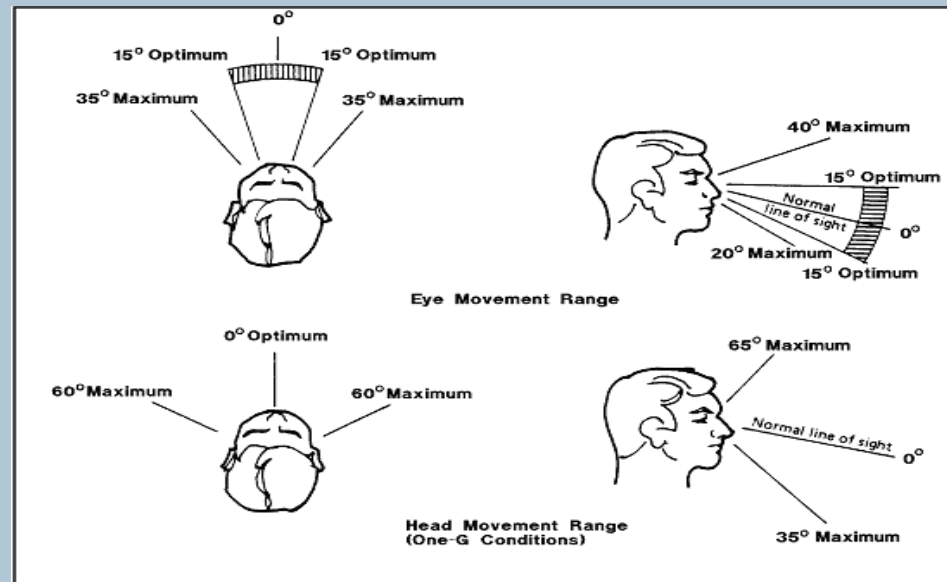

Requirements are transformed;

They become Critical Technical Parameters (CTPs) and Software Design or System Specifications (SDS/SS).

Systems are built and tested based on specifications, whether they be software or system.

Specifications define how a system must function and support system requirements.

If requirements are so vague that they cannot be supported by specifications how can the requirement be met or tested?

# The Role of Test and Evaluation

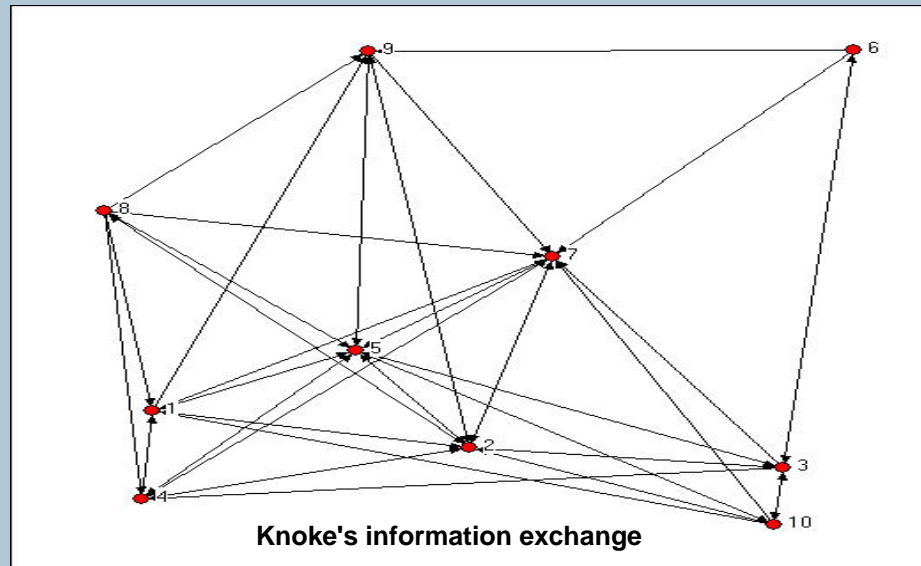

Testing SoS requires that the system be evaluated for acceptability by the end users, the target audience, the purchasers, and other stakeholders.

It is resource intensive to test all individual IERs, we must rely on testing the outcome of their contribution to the system, as defined in our specifications, to evaluate the systems overall acceptability.

We must know what will not be tested as part of our evaluation in order to examine whether this imposes risk to the performance, or our stakeholders acceptance of the system.



# The Role of Test and Evaluation



[http://www.toronto.drdc-rddc.gc.ca/facilities/specialized\\_e.html](http://www.toronto.drdc-rddc.gc.ca/facilities/specialized_e.html)

Other areas for requirements that need to be addressed are the Humans in the Loop (HITL) and Human System Interfaces (HSI).

These provide a whole set of other requirements and can be resource intensive to evaluate. If our SoS require HITL at several different systems' locations the complexity of the testing is increased greatly.

The performance of most systems, however; is tied to the performance of HITL and to ignore these requirements would add risk to the systems acceptability.

# The Role of Test and Evaluation



Another dimension of HITL that is not normally designed into testing is the ability of personnel to utilize the system in ways that had not been imagined when the system was designed.

This can be a positive or a negative factor but is a valuable input into the systems' readiness.

It is important that testing is not always strictly scripted to give the operators latitude when conducting their portion of the evaluation. Doing this will often lead to discoveries testers had not anticipated!

# Summary

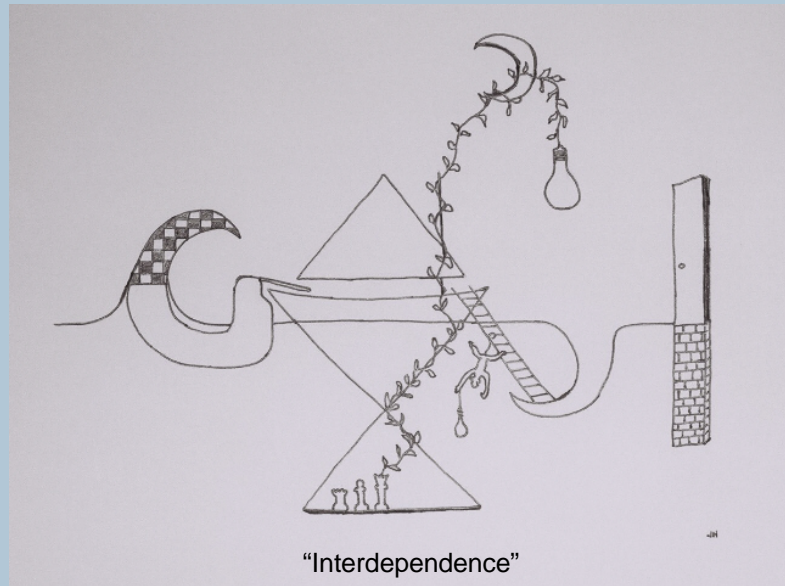

[http://www.modernartwork.net/gallery\\_Modern\\_Art\\_Work\\_drawings.htm](http://www.modernartwork.net/gallery_Modern_Art_Work_drawings.htm)

The interdependence of Requirements Definition, Test, and Evaluation takes place throughout the program cycle.

To exclude T&E from the beginning stages of requirements development is to preclude more opportunity for synergy.

To operate in an efficient manner all components of a system must work together; this is a basic definition of a system. Why would we as the systems engineers want to deny this basic truth and eliminate the T&E capability of our acquisition system?