



U.S. AIR FORCE

UNCLASSIFIED



GLOBAL PERSISTENT ATTACK ARCHITECTURE, PROCESS, AND RISK ANALYSIS

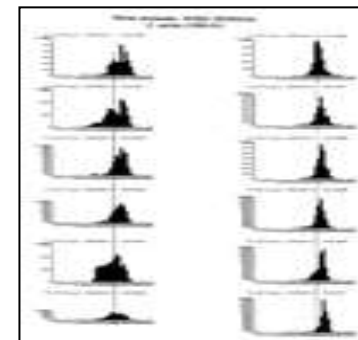
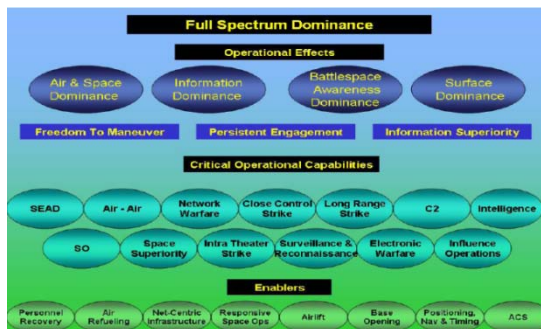
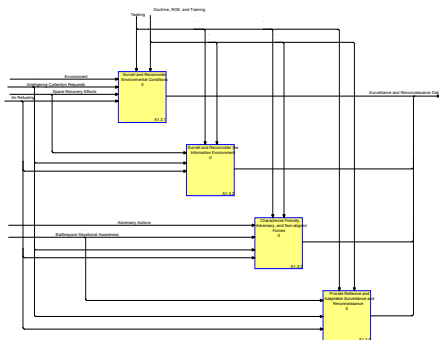

This Briefing is:
UNCLASSIFIED

Jeff Havlicek, Maj, USAF
SE Ed & Trng Div Chief
937-255-3355 x3348



U.S. AIR FORCE



Shape the future of systems engineering in the AF and DoD to improve our ability to deliver war-fighting capabilities. We will accomplish this by conceptualizing new processes, practices, tools, and resources for the systems engineering workforce through **research, education, and consultation.**



U.S. AIR FORCE

GRP Methodology

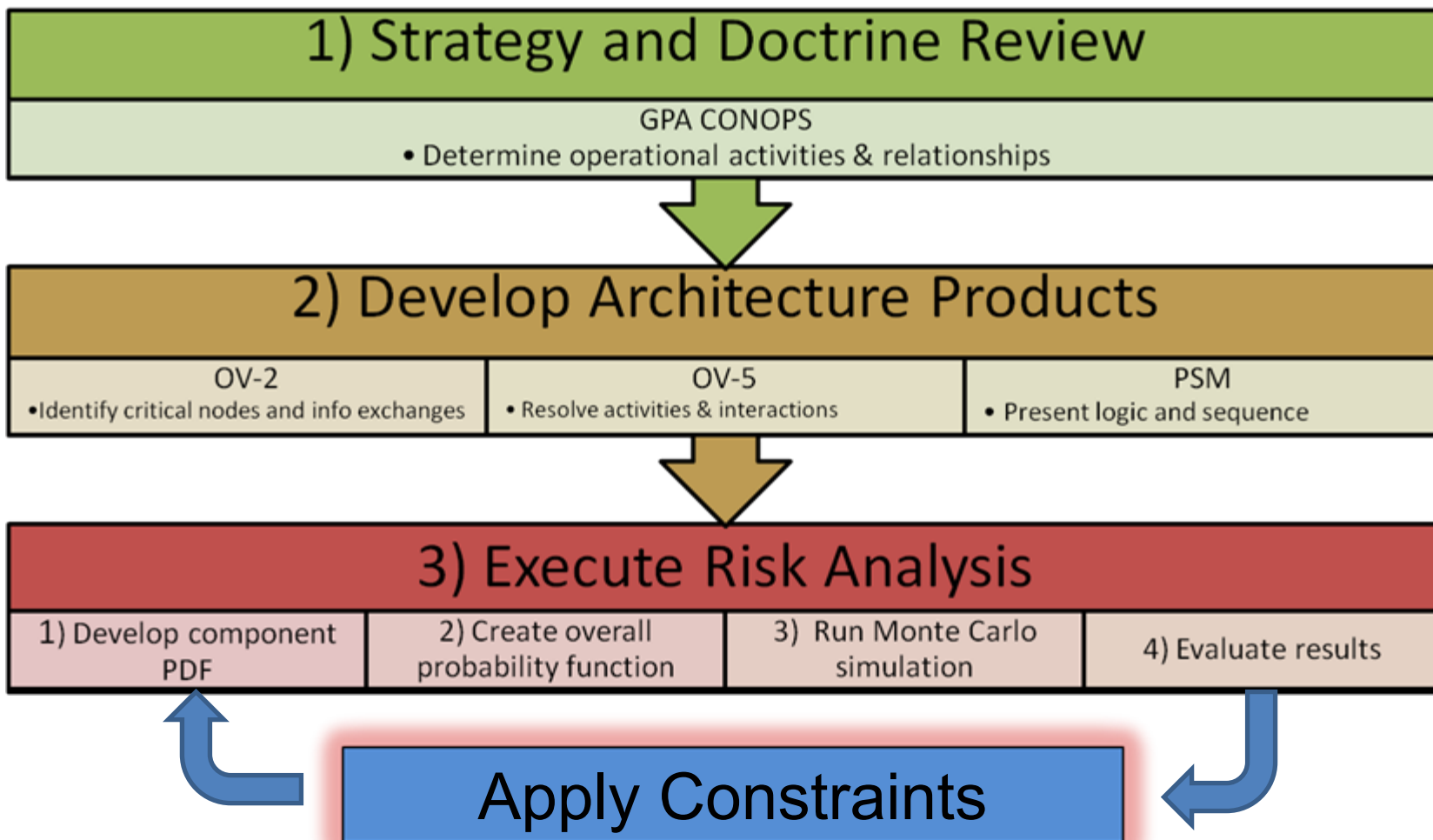



U.S. AIR FORCE

Strategy and Doctrine Review

UNCLASSIFIED

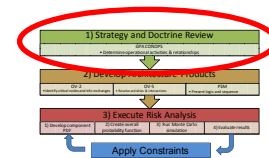

GPA CONOPS

GLOBAL Battlepace Awareness Dominance

4.A.3.a. Command and Control (C2). C2 includes the ability to monitor and assess the battlespace and to direct forces in the execution of Effects Based Operations (EBO) in any threat environment. A refined element of C2 is BMC2. BMC2 enables seamlessly integrated, coordinated and synchronized forces to execute persistent operations. This requires a robust surveillance and reconnaissance architecture and capabilities to support understanding the adversary's environment and positioning of

4.A.3.b. Intelligence. Intelligence includes the ability to produce and provide the analytical products required to conduct Effects Based Operations, Effects Based Assessments, and is a key element of *Proactive Battlespace Awareness (PBA)*, which allows commanders to anticipate future events and adversary courses of action. Intelligence correlates and fuses all sources of data, patterns of enemy activity, environmental conditions and relevant events to assess the operating environment and predict

4.A.3.c. Surveillance and Reconnaissance. Surveillance and Reconnaissance (S&R) includes the ability to persistently collect data on the air, land, sea, space, and cyber environments, and to continuously characterize all friendly, adversary, and non-aligned forces and relevant low-signature human activity. This includes people, soft vehicles, small buildings, and occasional armored vehicles. In complex environments, where adversaries may attempt to deny access to US forces, they will likely employ camouflage, concealment, deception and burying. GPA operations require a robust global

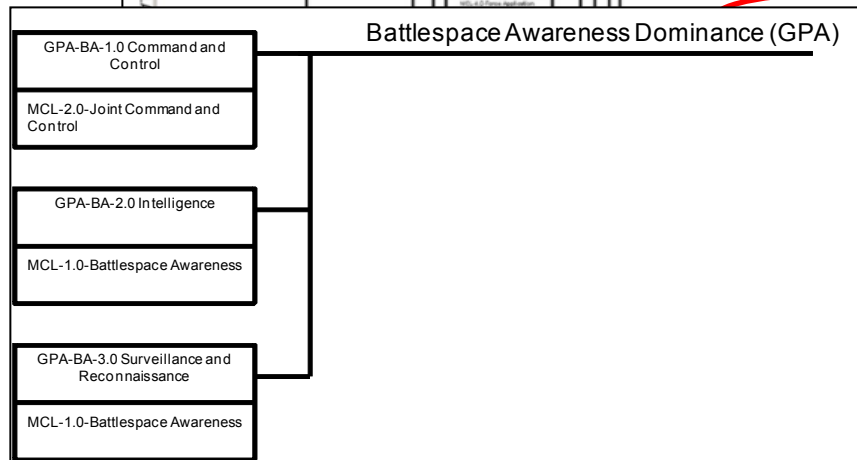
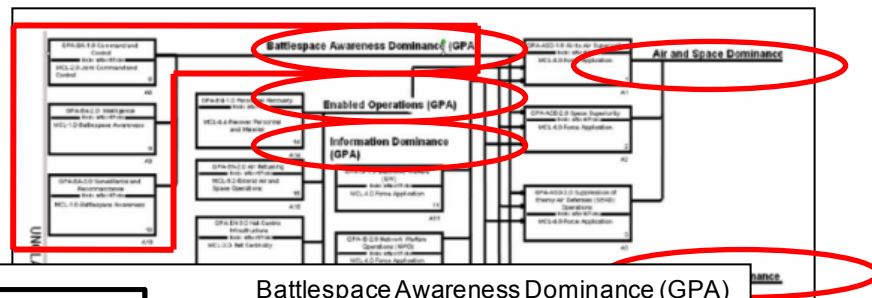

UNCLASSIFIED

Integrity - Service - Excellence



U.S. AIR FORCE

Operational Node Description (OV-2)

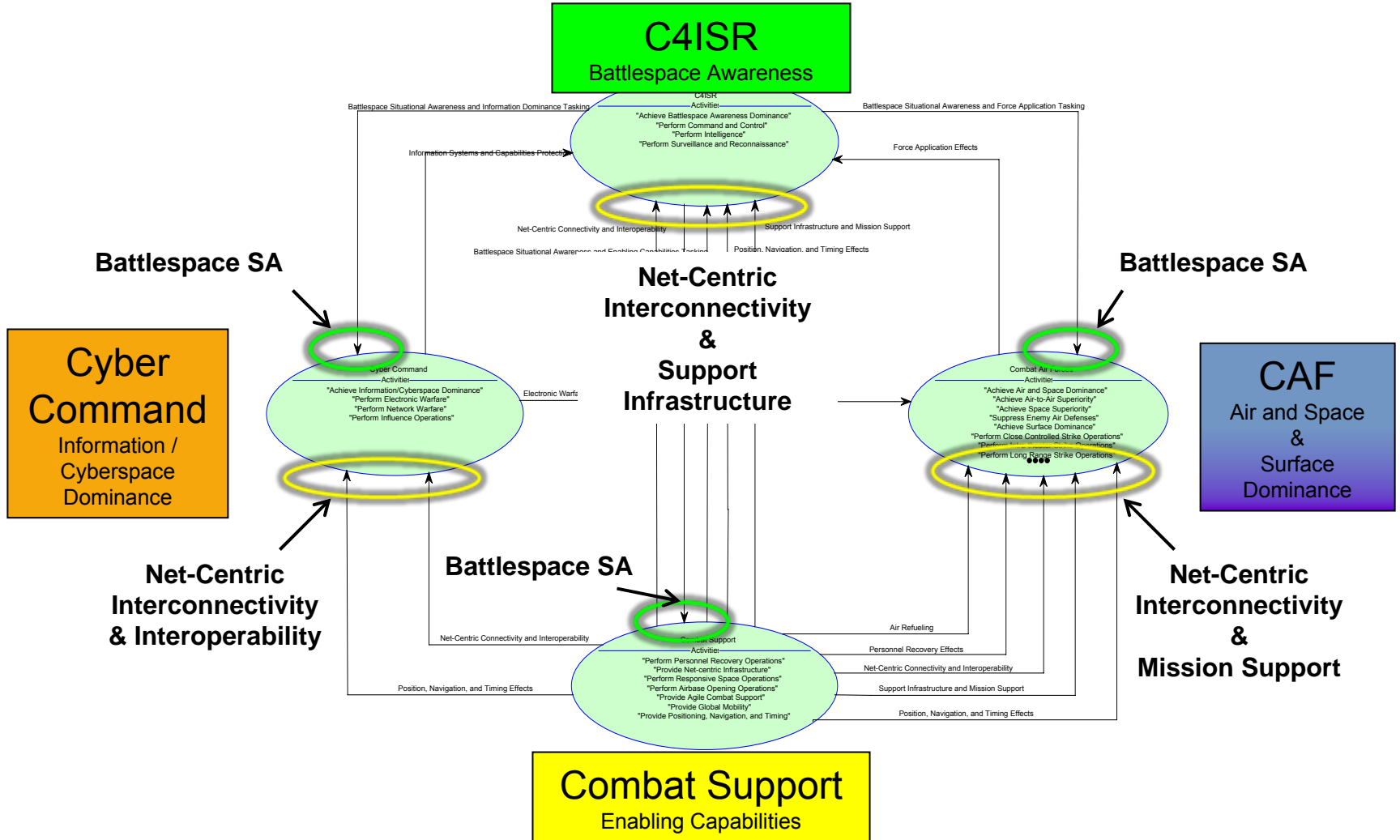
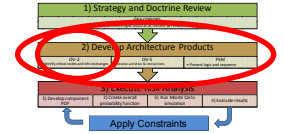



U.S. AIR FORCE

Operational Activity Hierarchy

UNCLASSIFIED

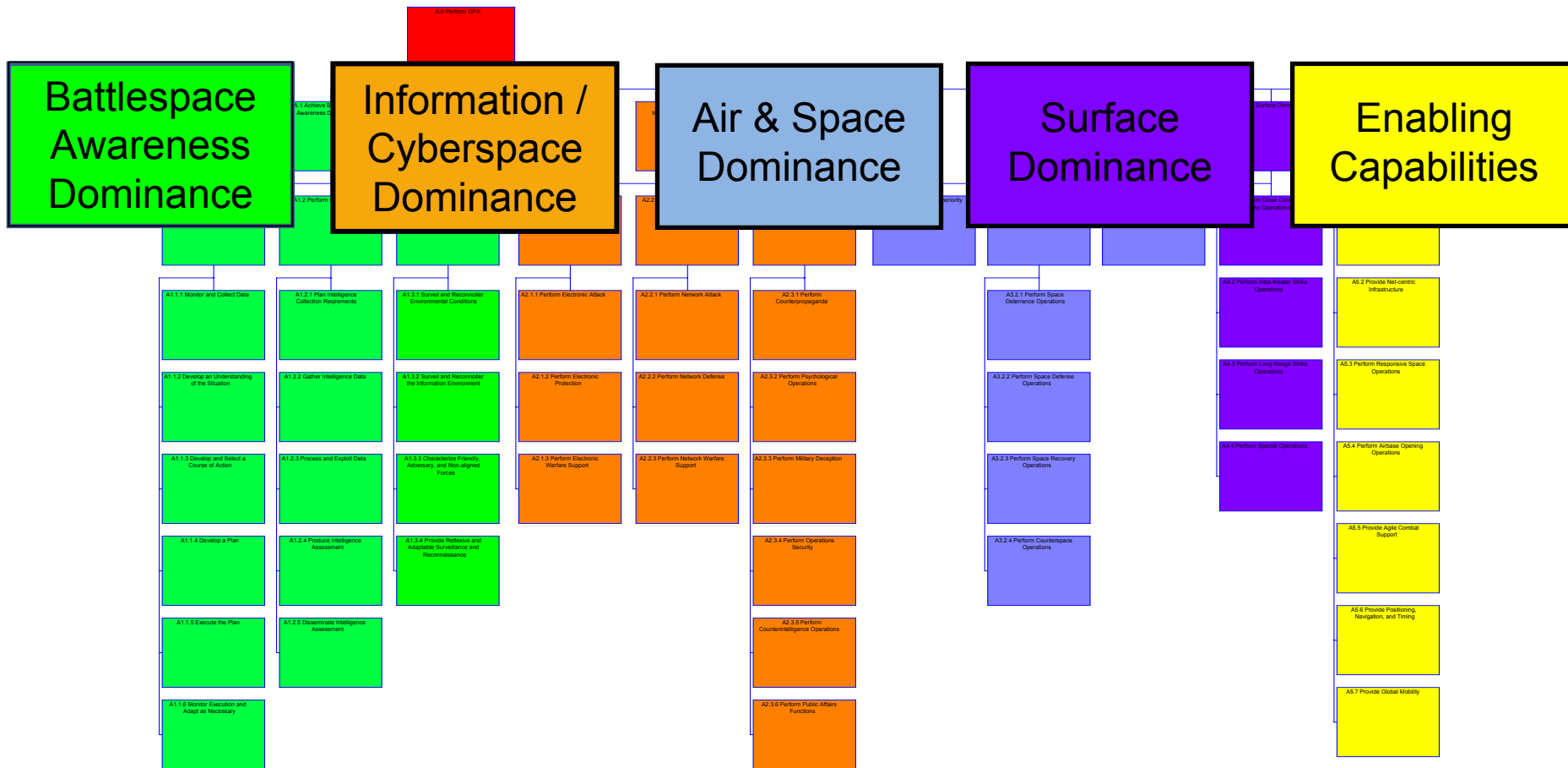
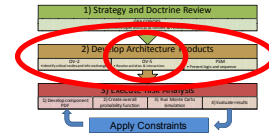

UNCLASSIFIED

Integrity - Service - Excellence



GPA A0 Diagram (OV-5)

U.S. AIR FORCE

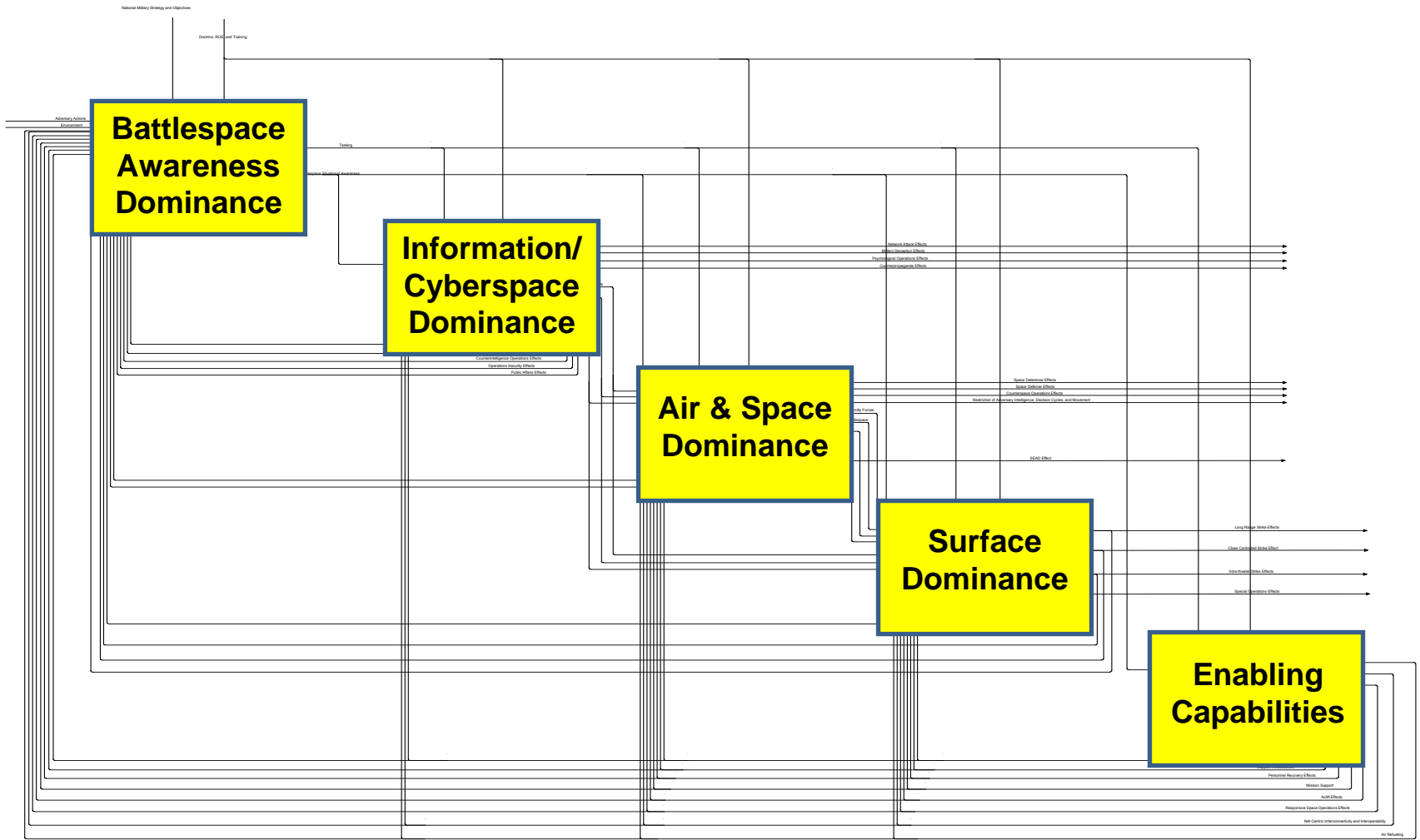



Battlespace Awareness

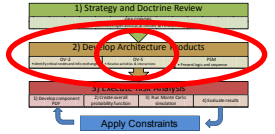

U.S. AIR FORCE

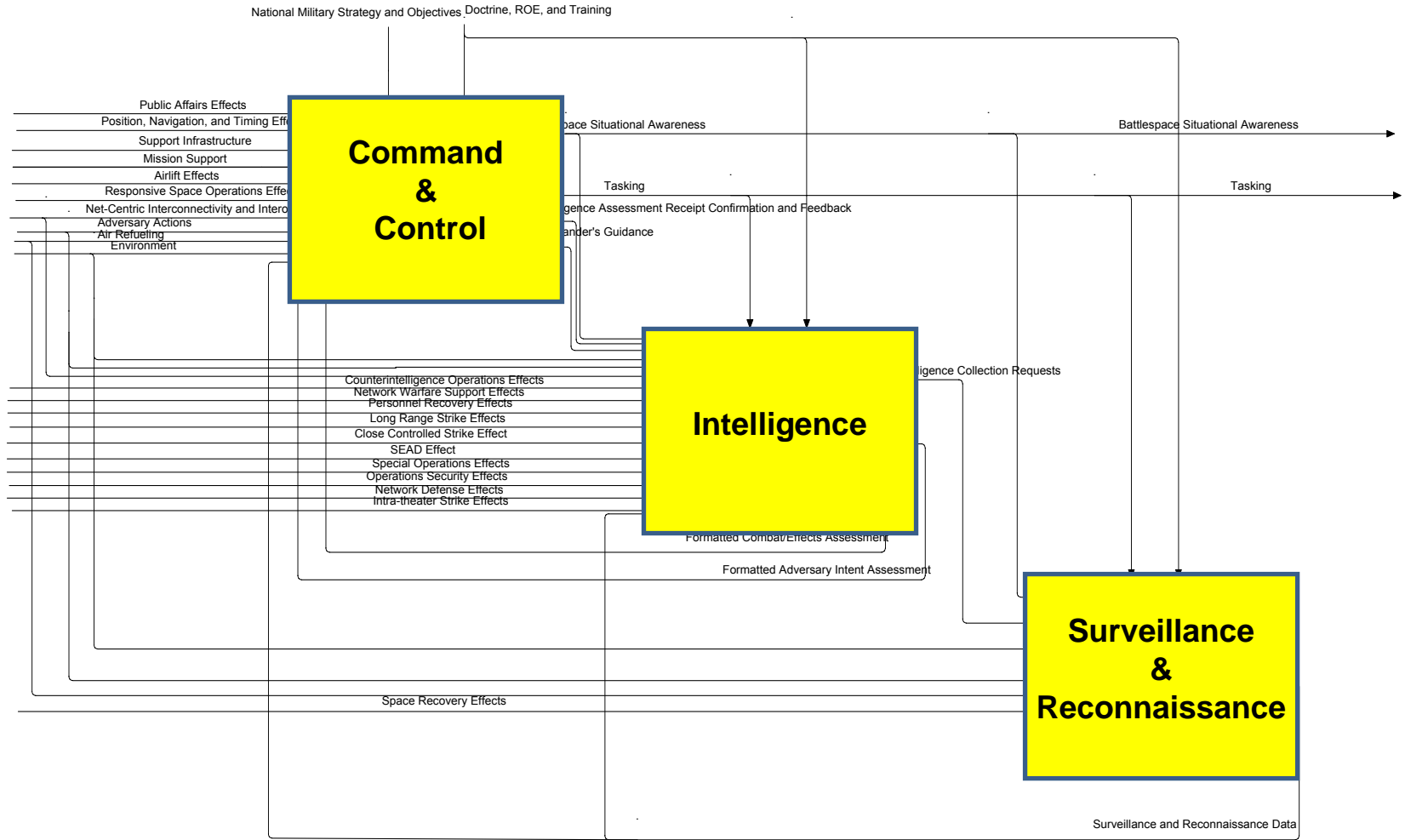



Battlespace Awareness

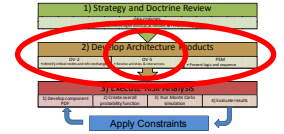

U.S. AIR FORCE

Command and Control

Command and Control JFC

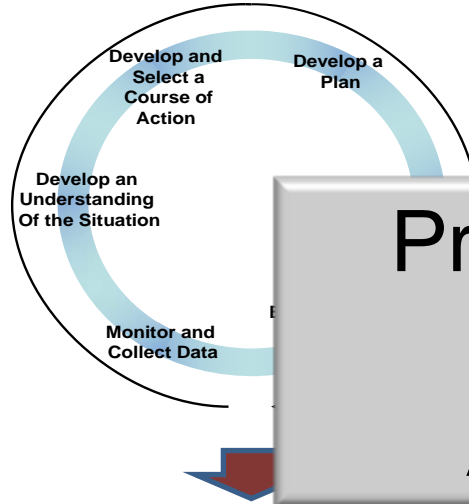

Intelligence

Joint Pub 2-01



Surveillance and Reconnaissance

AF C4ISR CONOPS

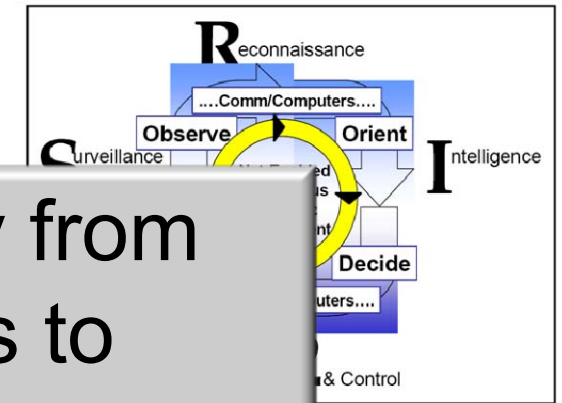

Provides Traceability from Strategic Concepts to Architectural Products

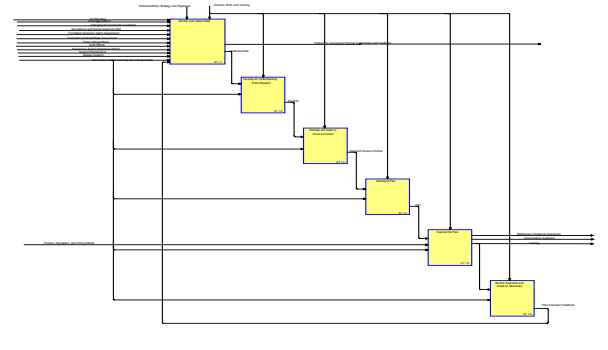
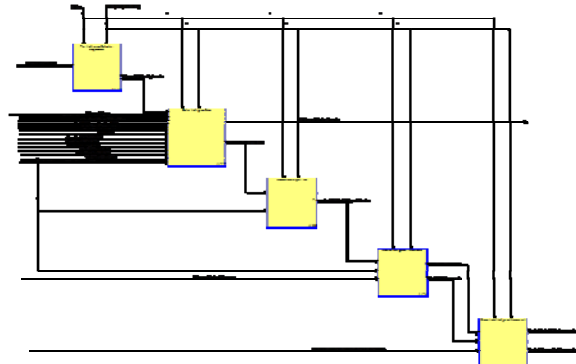
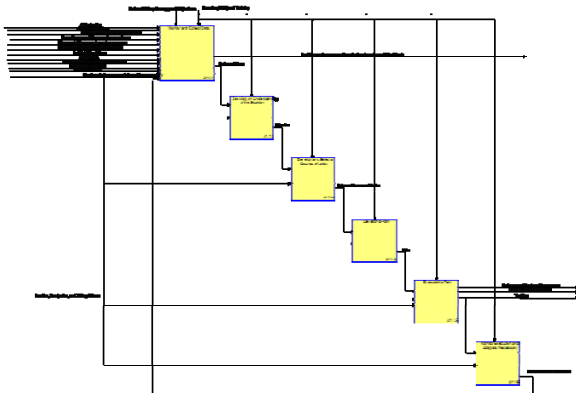



Methodology - PSM

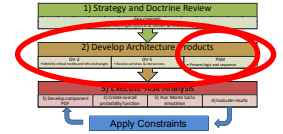

U.S. AIR FORCE

- Apply Sequencing Logic for Risk Quantification
- Based on “Global Power” PSM
 - Uses F2T2EA Framework
 - Adaptable!

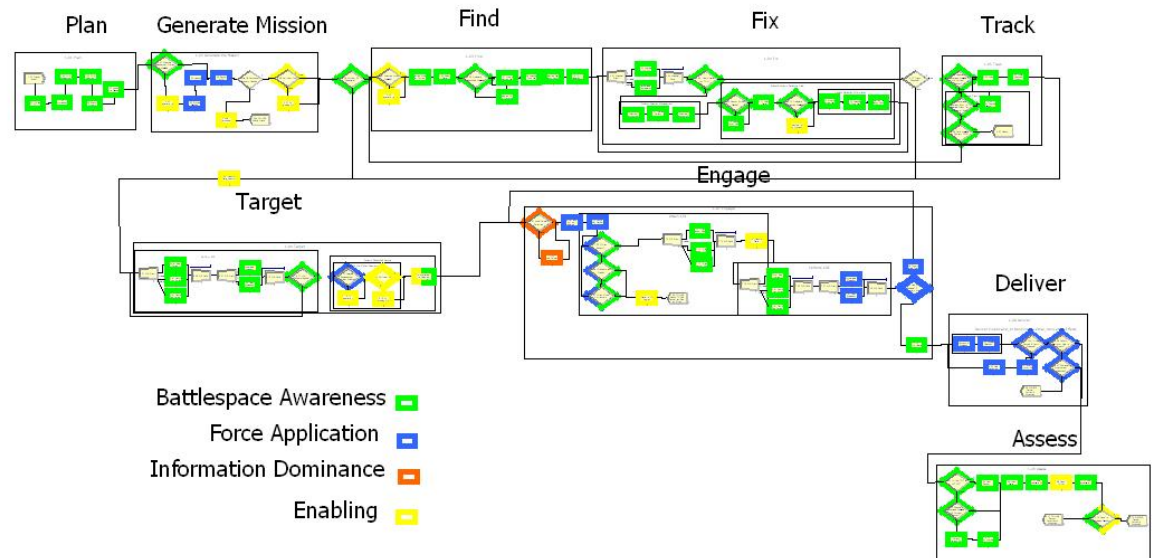



OV-5 to PSM Mapping

U.S. AIR FORCE

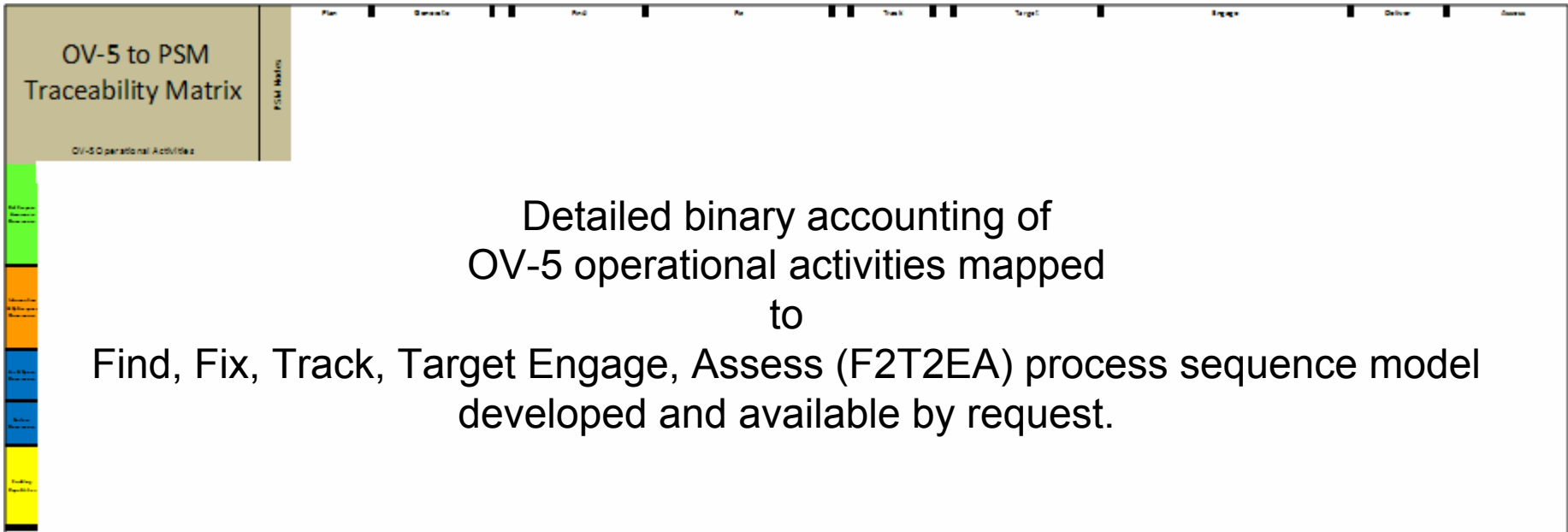
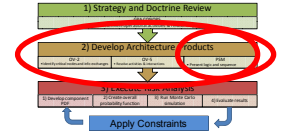

Result: Requirements Traceability!
 What needs to happen is mapped to when and how it will happen.



Methodology - PSM

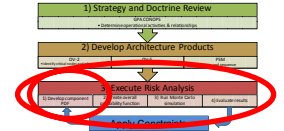

U.S. AIR FORCE

PDF Development

- P(s) PDF – Probability of successfully completing activity
- Based upon available data, SME input, and/or modeling and simulation results
- Reflects both capability and sufficiency
- Research used Triangular PDFs

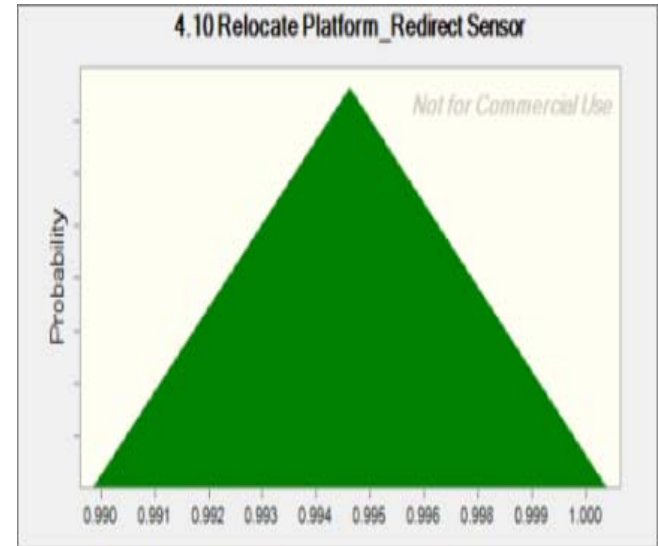
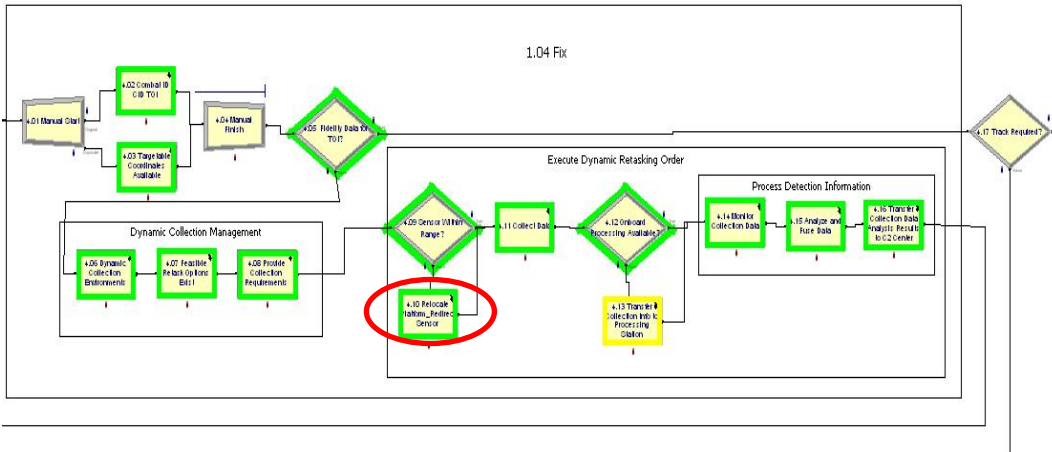

Triangular Distribution:

Minimum: .99
 Likeliest: .995
 Maximum: 1.00



Methodology - PSM

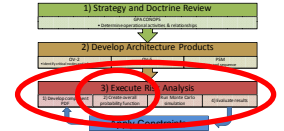

U.S. AIR FORCE

PSM Structure Function

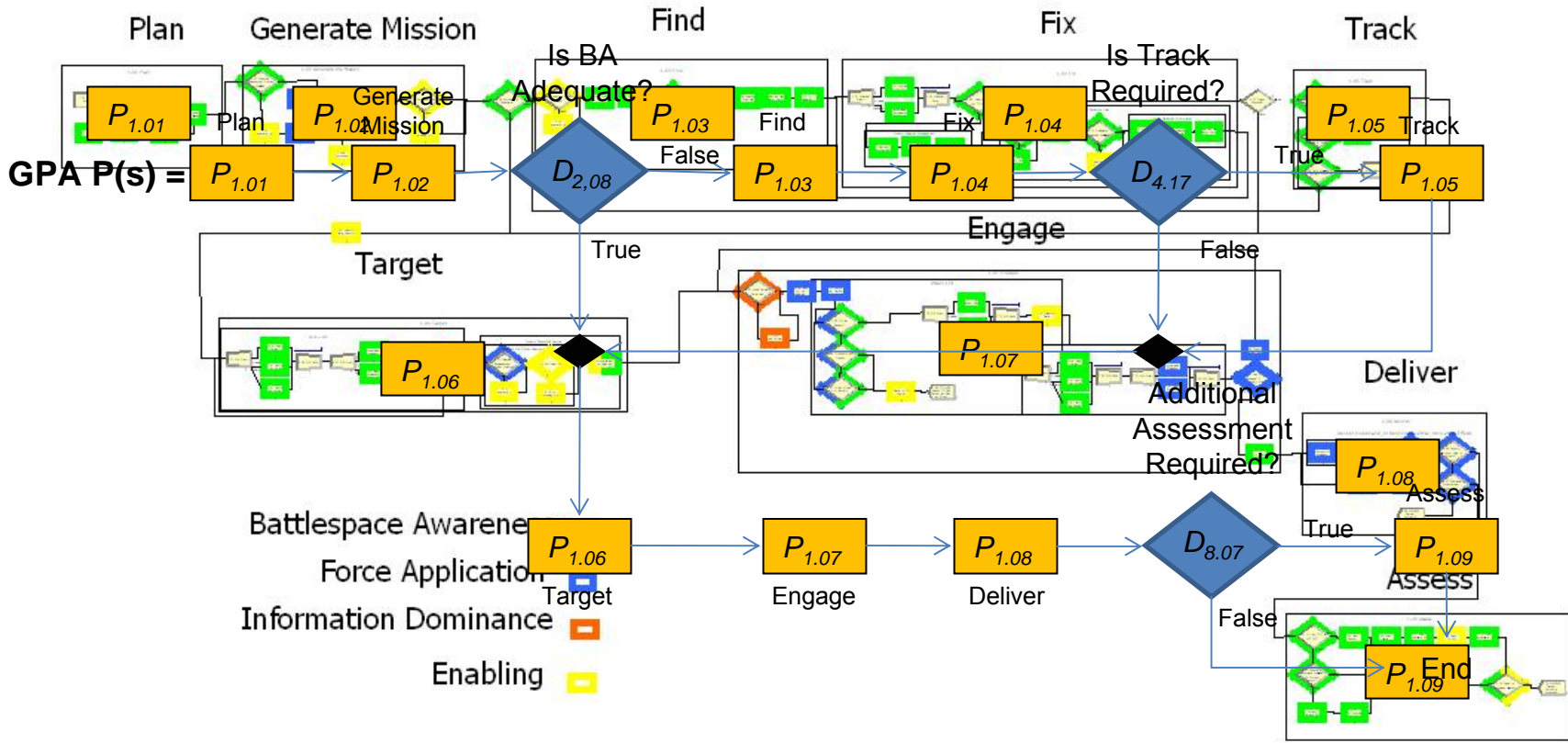



Methodology - PSM

U.S. AIR FORCE

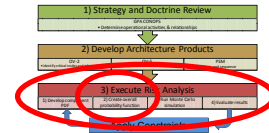

PSM Structure Function

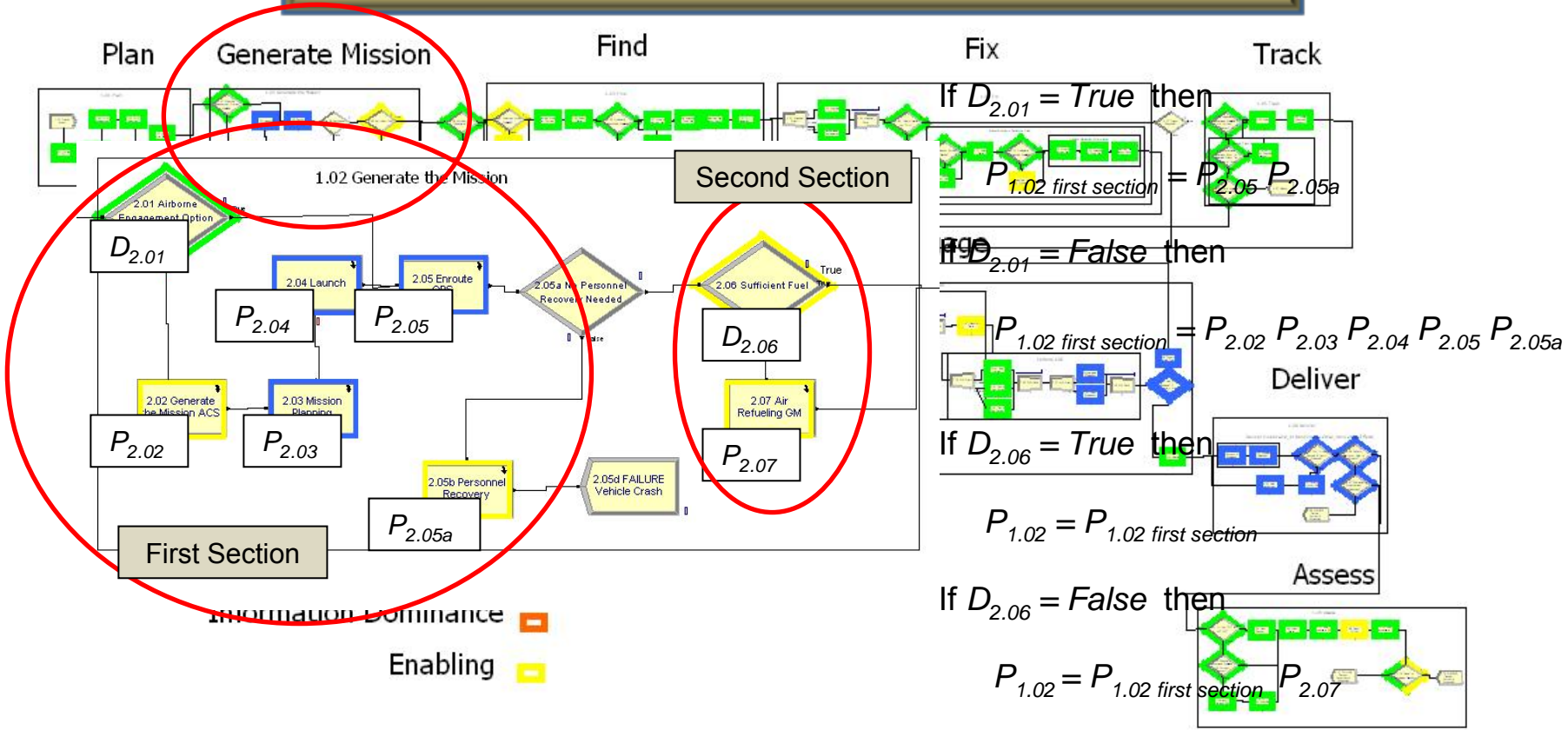



U.S. AIR FORCE

Analysis & Results



Fiscally Constrained Force Assumptions

- Slipping C2ISR Modernization Program
- Closing F-22 Line After Lot 9
- Cutting or Slipping F-35 Program
- Cutting or Slipping New Tanker Development
- Failing to Develop New Long Range Bomber

Assumptions for Proof of Concept Only



Analysis & Results

U.S. AIR FORCE



C2ISR Affected Nodes

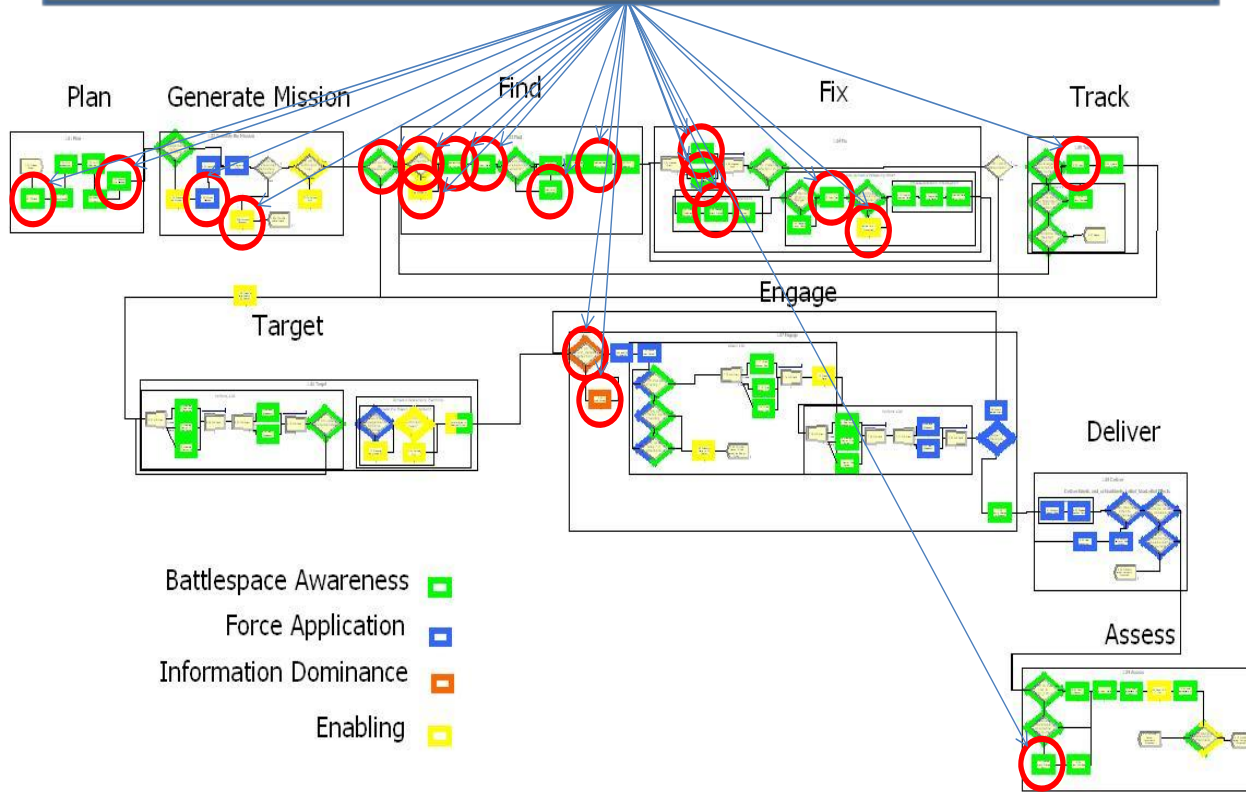



U.S. AIR FORCE

Analysis & Results

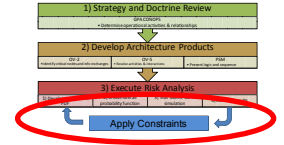

F-22 Affected Nodes

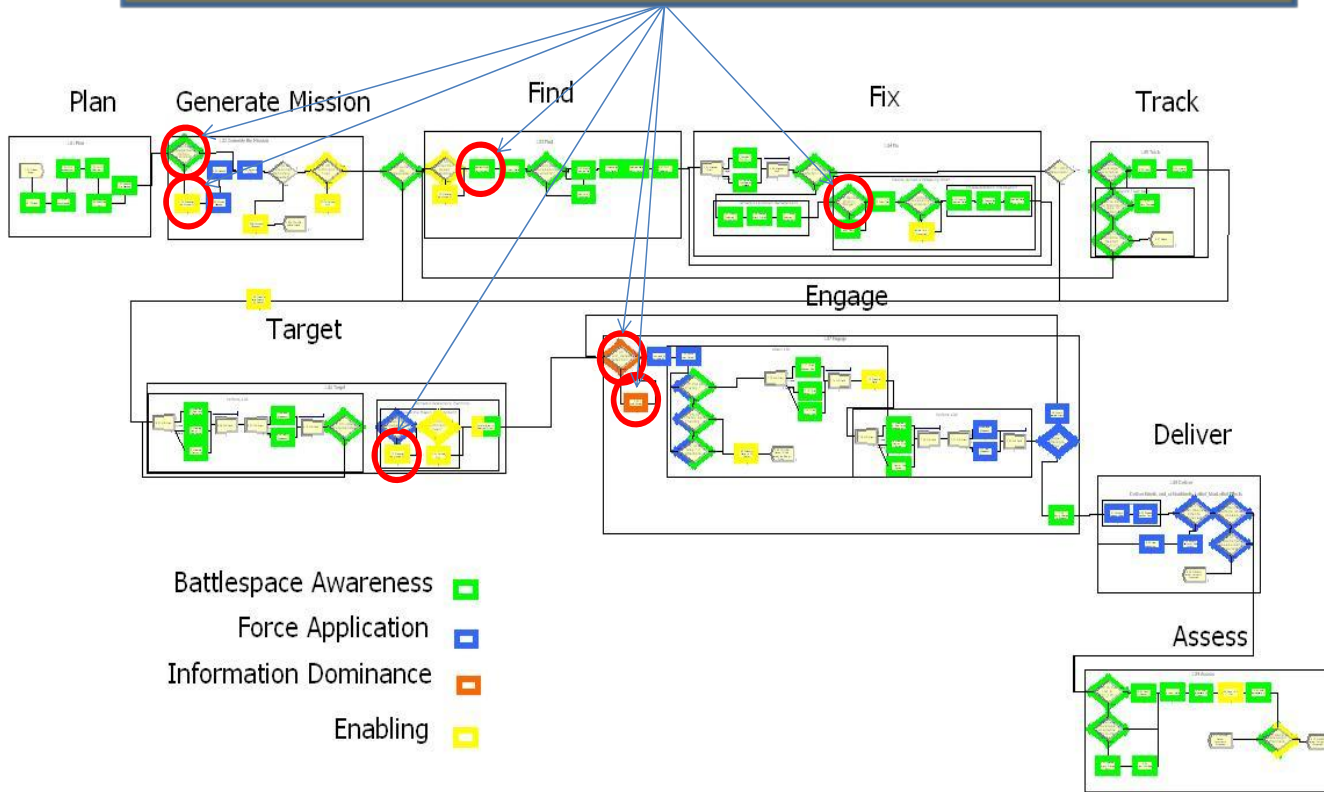



Analysis & Results

U.S. AIR FORCE



F-35 Affected Nodes

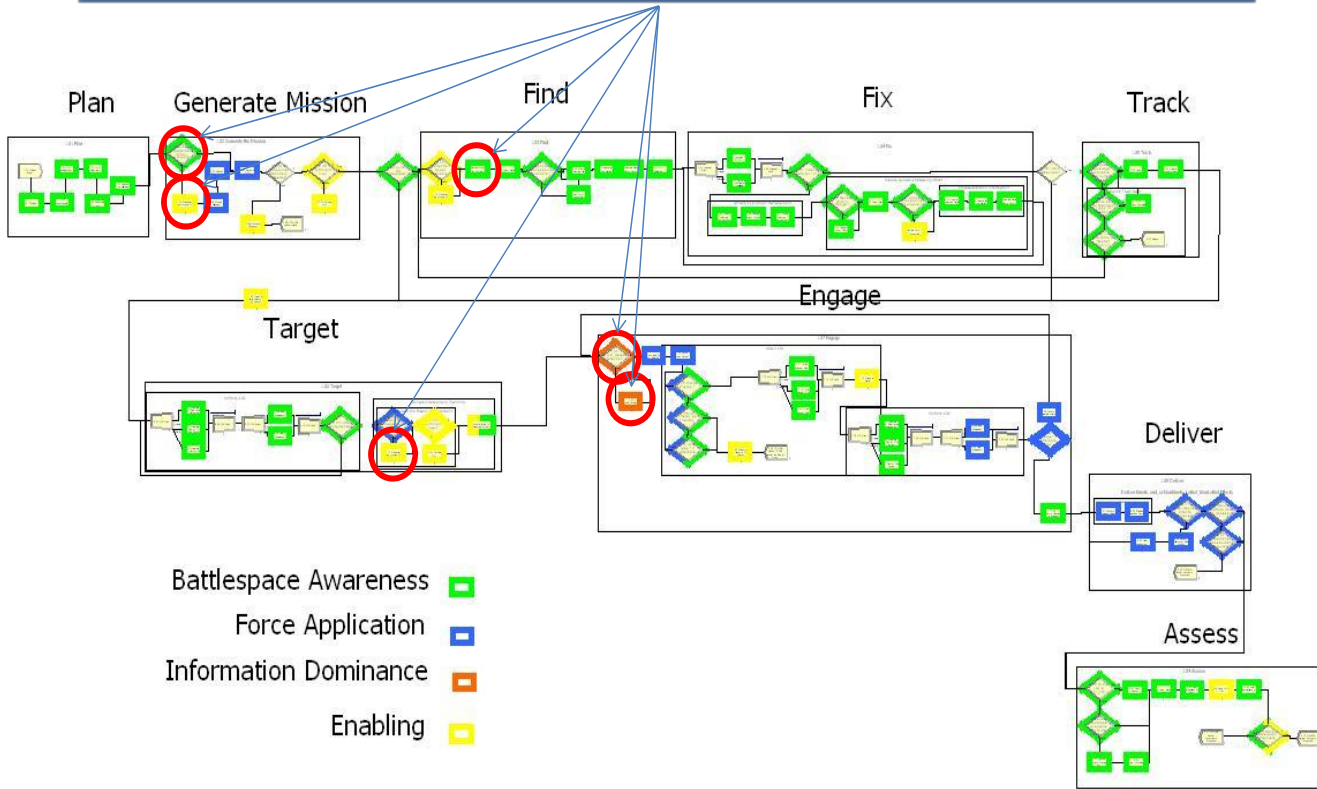



Analysis & Results

U.S. AIR FORCE

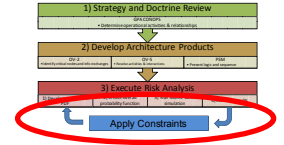

Tanker Affected Nodes

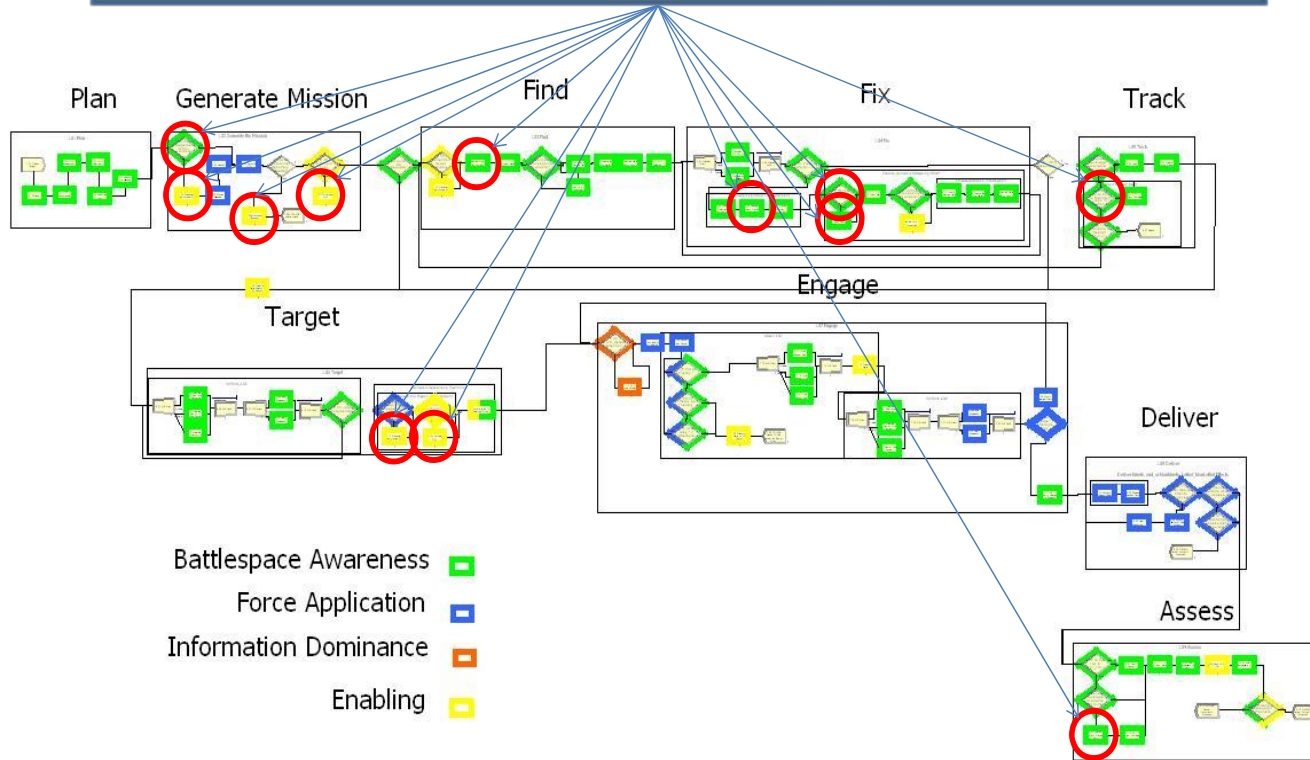



Analysis & Results

U.S. AIR FORCE



Bomber Affected Nodes

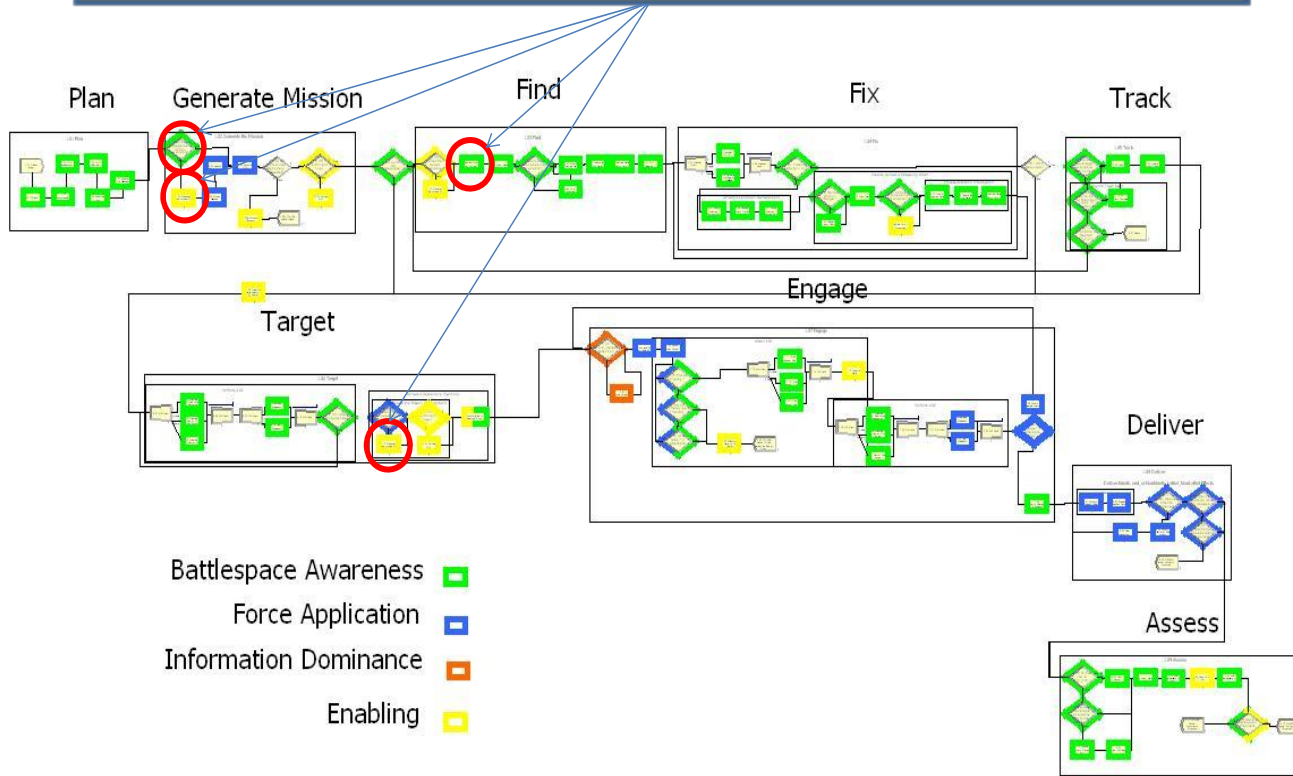



Analysis & Results

U.S. AIR FORCE

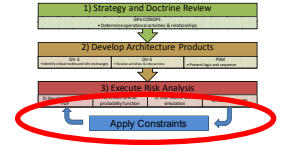

FCF Affected Nodes

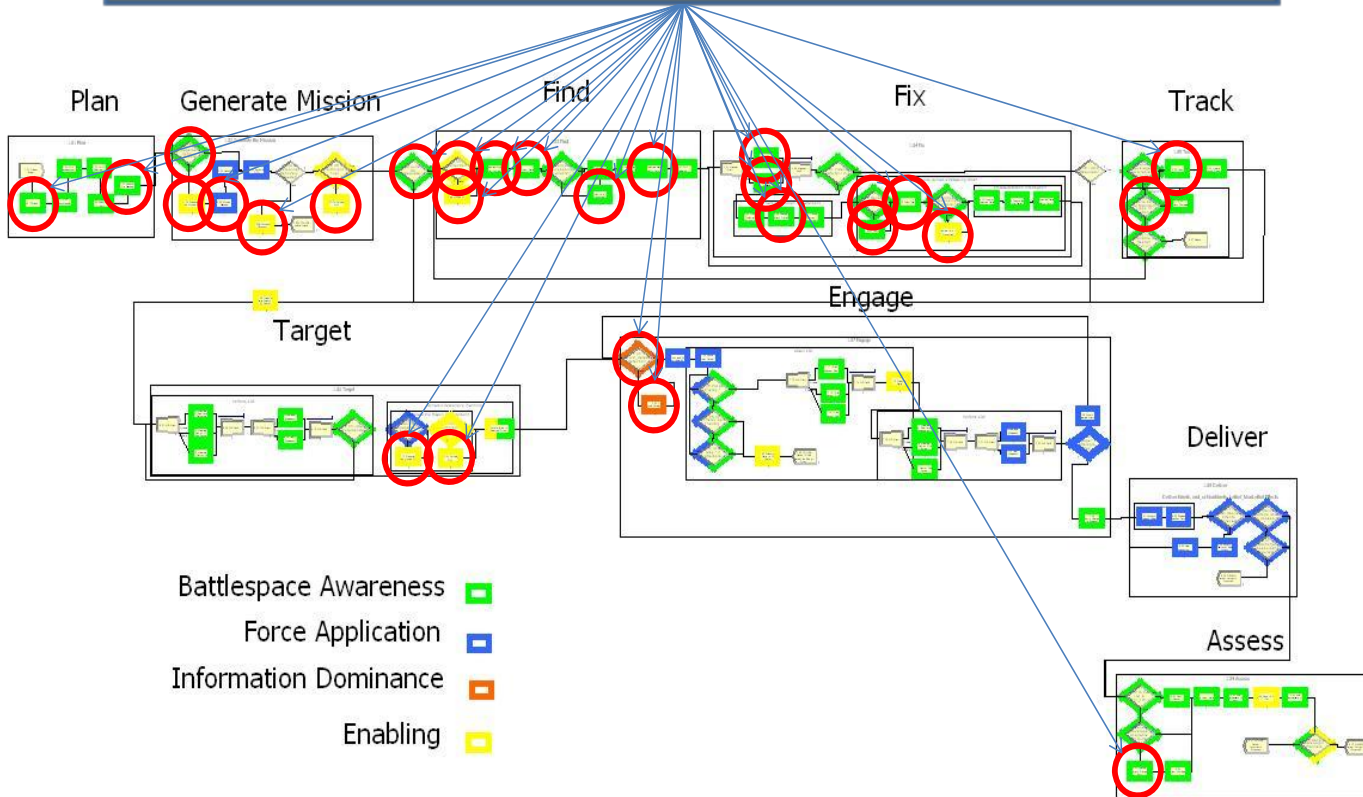



Analysis & Results

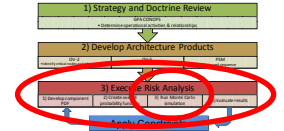

U.S. AIR FORCE

Fiscally Constrained Force

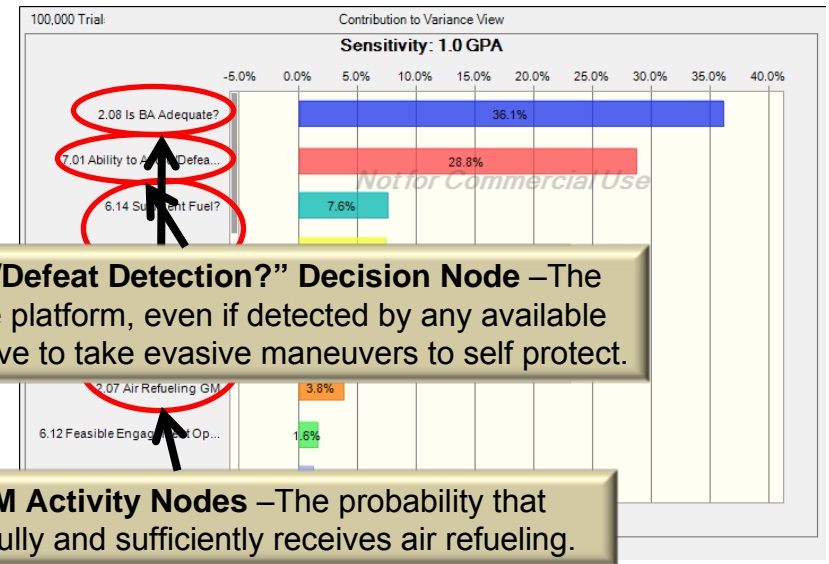
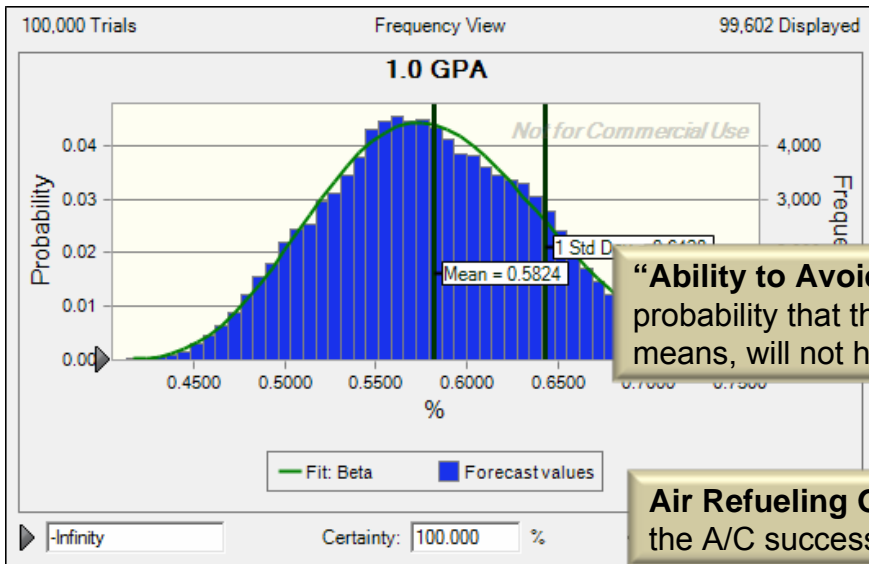

“Ability to Avoid/Defeat Detection?” Decision Node –The probability that the platform, even if detected by any available means, will not have to take evasive maneuvers to self protect.

Air Refueling GM Activity Nodes –The probability that the A/C successfully and sufficiently receives air refueling.



Analysis & Results

U.S. AIR FORCE

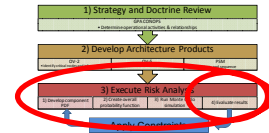

FCF Critical Nodes

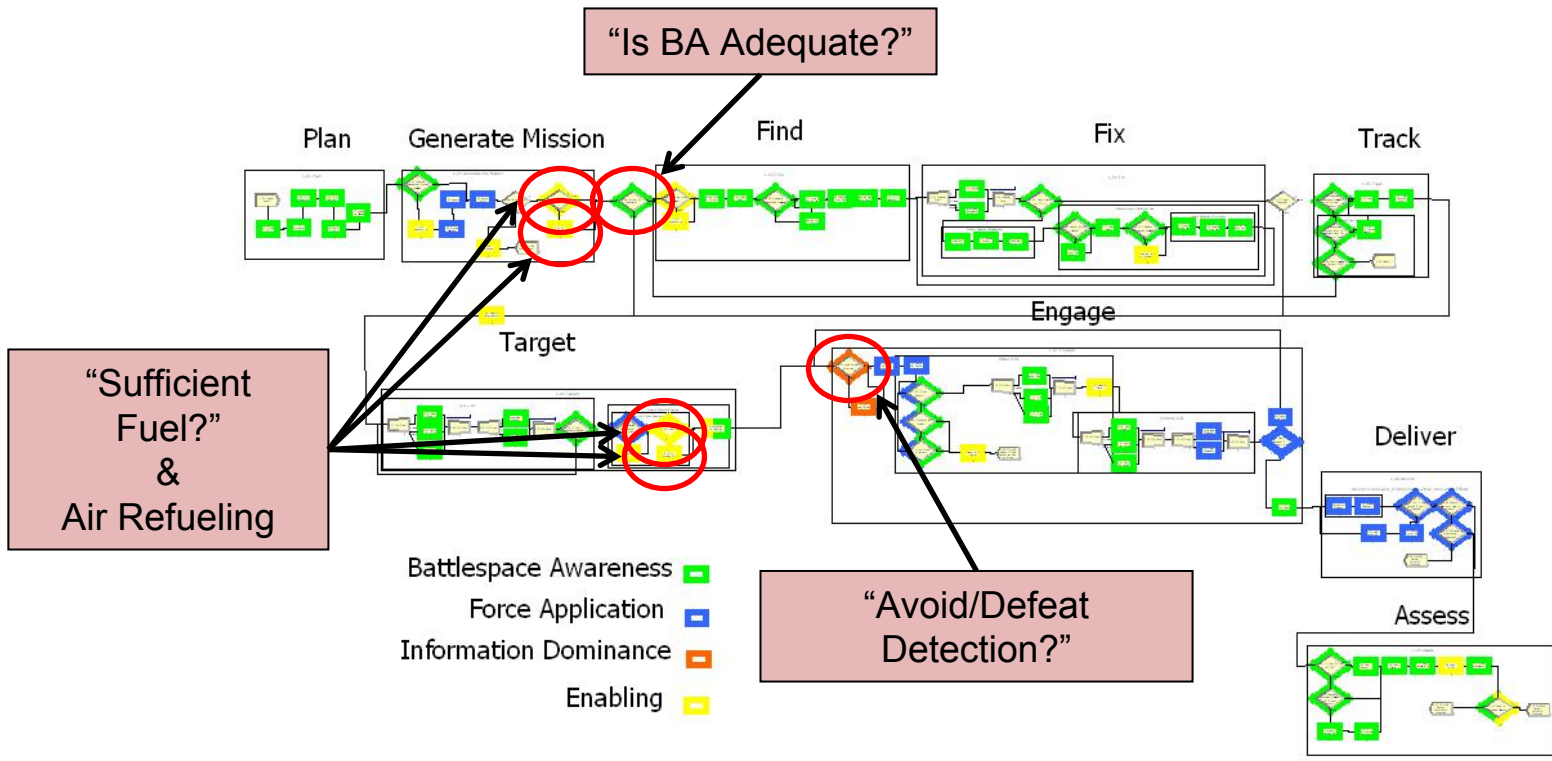



Analysis & Results

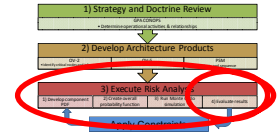

U.S. AIR FORCE

FCF Independent Analysis of Constraints

- 1. Tanker
- 2. C2ISR
- 3. F-22
- 4. F-35
- 5. Bomber

P(s) Distribution Results	Sample Mean (μ)						
	SRF	C2ISR	F-22	F-35	Tanker	Bomber	
Overall Results	0.8683	0.7551	0.8493	0.7122	0.7122	0.8754	8.9% Decrease
Is BA Adequate? = Yes	0.8831	0.7937	0.8672	0.8672	0.7271	0.8754	1.6% Decrease
Is BA Adequate? = No	0.8341	0.7165	0.8081	0.6774	0.6774	0.8754	11.8% Decrease

P(s) Distribution Results	Sample Standard Deviation (S)						
	SRF	C2ISR	F-22	F-35	Tanker	Bomber	
Overall Results	N/A	N/A	N/A	N/A	N/A	N/A	≈ 1.5 times Greater
Is BA Adequate? = Yes	± 0.0115	± 0.0175	± 0.0204	± 0.0204	± 0.0408	± 0.0164	≈ 1.5 times Greater
Is BA Adequate? = No	± 0.0137	± 0.0216	± 0.0209	± 0.0208	± 0.0385	± 0.0164	≈ Same



Analysis & Results

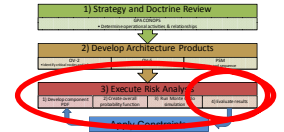

U.S. AIR FORCE

FCF Sensitivity by Capability

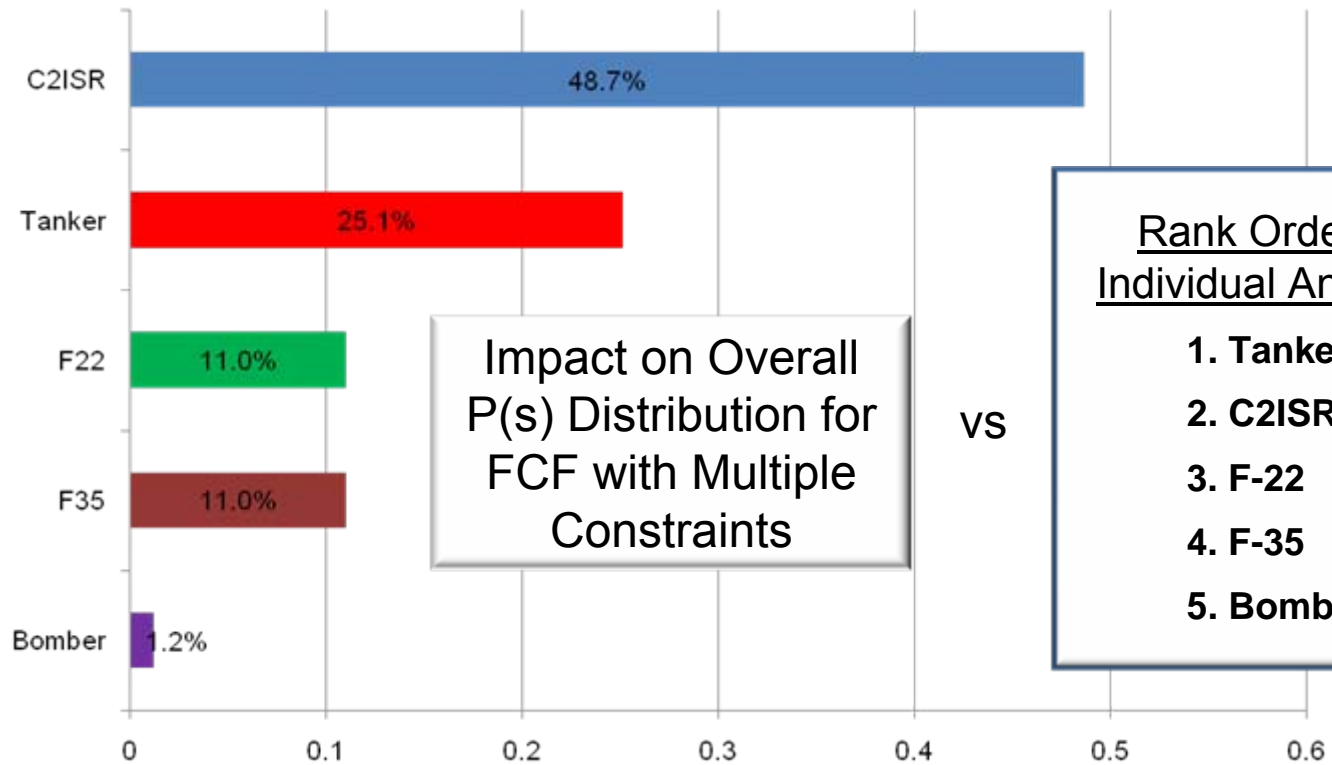

Impact on Overall P(s) Distribution for FCF with Multiple Constraints

vs

- Rank Order of Individual Analysis
1. Tanker
 2. C2ISR
 3. F-22
 4. F-35
 5. Bomber



U.S. AIR FORCE

Analysis & Results

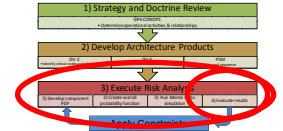

Analysis Conclusions

Analysis of individual constraints independently highlighted **Tanker** constraint as having greatest impact

but

Combined effects of all constraints resulted in **C2ISR** modernization constraint as most important to overall success!

Based Upon Research Assumptions



Recommendations



U.S. AIR FORCE

Phase I

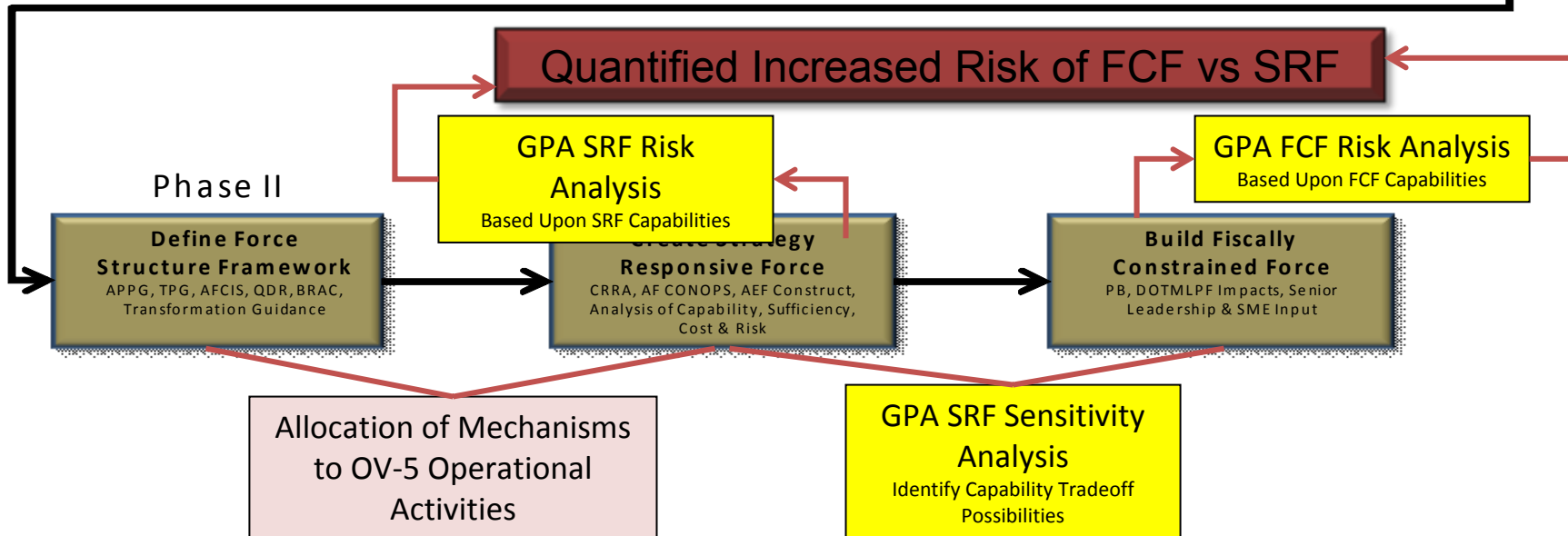
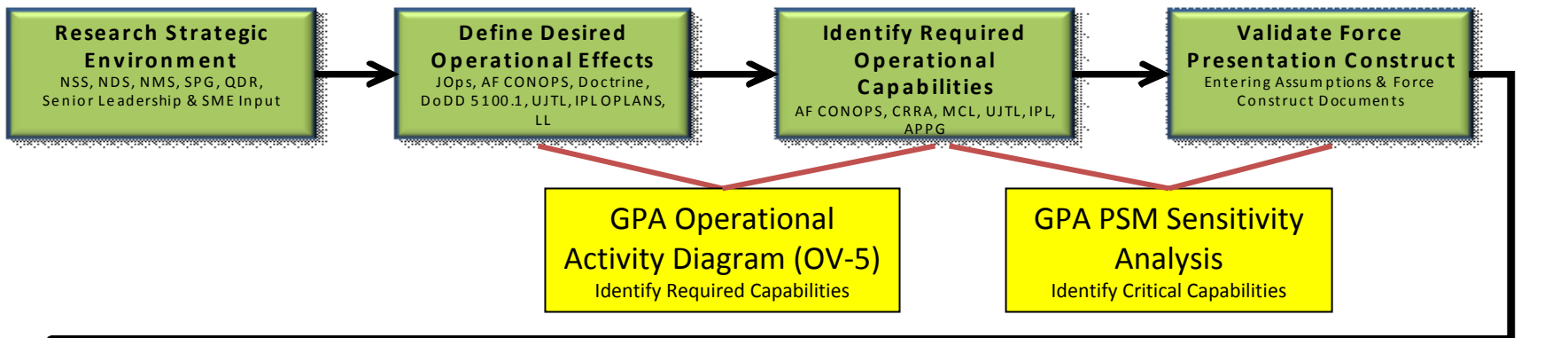



U.S. AIR FORCE

Summary



- **Use Risk Analysis Methodology to Indentify Key SoS Interdependencies to Quantifies Risk and Identify Critical Capabilities**
 - **Methodology Requires Multiple Iterations!**
- **Architecture and PSM for GPA SoS**
- **Risk Analysis of GPA SoS**
 - **Quantify Risk for Each Force Construct**
 - **Identify Critical Capabilities**
 - **Notional Analysis Identified C2ISR as Most Critical**
- **Integrate Into Force Construct**