

155 Third Generation Maritime Fire Support (155 TMF)

Robert McClure
BAE Systems Global Combat Systems



Contents

- BAE Systems Context
- Global Combat Systems Products
 - AS90 Self Propelled
 - Mk8 4.5" Naval Gun
- Maritime Fires Capability Requirement
- 155mm Third Generation Maritime Fire Support (TMF)
- Summary & Questions



BAE Systems Context

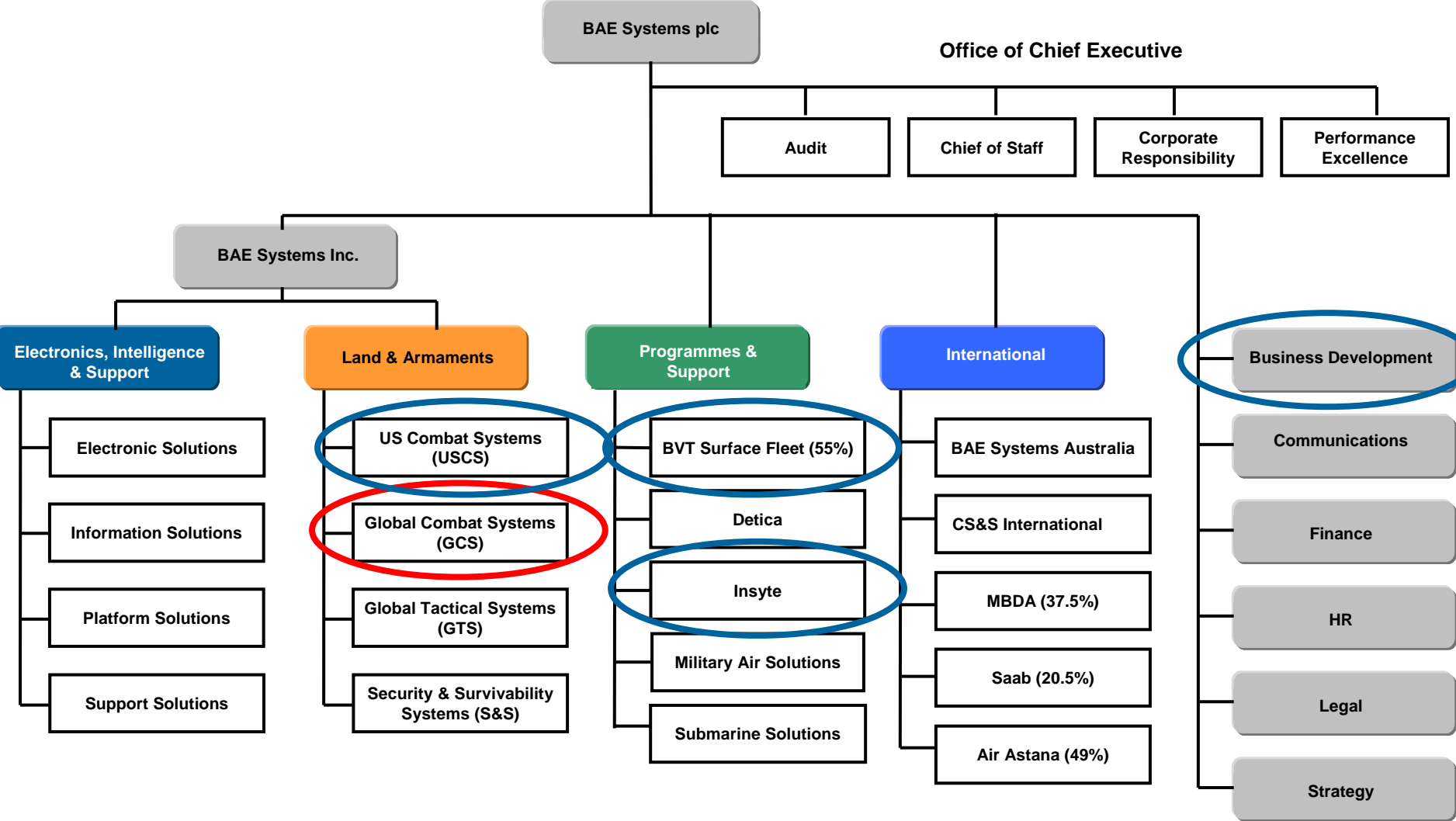

155mm **T**hird Generation **M**aritime **F**ire Support (TMF)



AS90 Self Propelled Howitzer

- Entered service in 1993 following competitive tender
- 179 vehicles over six UK regiments
- JBMoU 39 cal 155mm ordnance
 - Two piece ammunition
 - 24.7km range
 - HE, Illum, Smoke
 - Precision Guided Munitions capability
- Operational service in Op Telic
 - NAO reported 95% availability
- Contract to 'up-gun' to 52 cal barrel in 2002
 - Cancelled due to failure of modular charge system to meet requirements
 - Design experience and trials data pull-through



Mk8 4.5” Naval Gun

- Designed by RARDE – built by BAE Systems
 - First prototype 1966
 - Entered service (Iran) 1971
 - UK Service 1973 HMS Bristol
- UK Royal Navy standard Medium Calibre Gun
 - Type 21, 22, 23 frigates
 - Type 42, Type 45 destroyers
- In service in Brazil, Chile, Pakistan
- 4.5” one piece ammunition
 - Range 22km
 - 21kg shell
 - Base-bleed extended range
- BAE contacted in 1998 to develop mod 1 upgrade
 - Addresses obsolescence, reliability and maintainability
 - Tranche 1 completed by BAE Systems
 - Tranche 2 ongoing by DML



155 TMF Concept Objectives

- Affordable route to provide a significant increase in Naval Gun capability
 - Retain 4.5" Mk8 Mod 1 mount structures and high value components
 - Adapt AS90 ordnance
 - Modify for environment
- UK research driven by FSC
- Additional opportunities

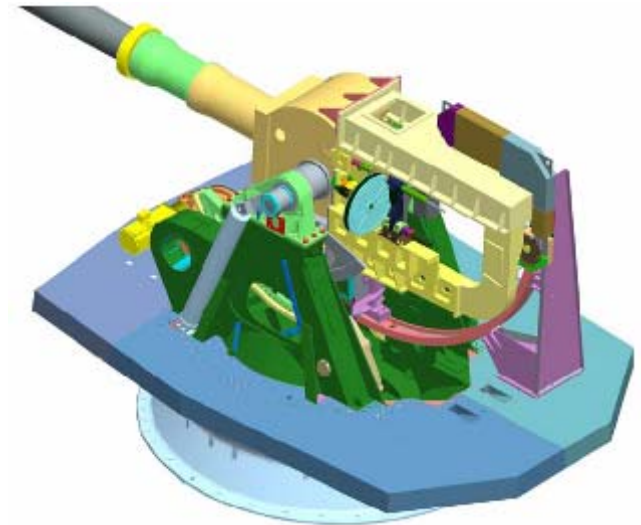

Maritime Fires Capability Requirement

- Factors
 - Future Surface Combatant to replace Type 23/22
 - Enduring need for Naval gun capability identified
 - Capability requirements evolving: effect, range, rate of fire
 - Objective to reduce whole life cost
 - 155TMF key programme for industrial capability
- FSC Options
 - No gun
 - Use existing gun: Mk8 4.5" - 114mm
 - Buy new
 - Upgrade: 155mm TMF
- So What?
 - UK Research programme mitigating technology risk
 - BAE Systems strategy based on 155mm TMF



TMF Key Attributes

Commonality with Mk8 drives low acquisition cost
Commonality with AS90 reduces development cost
Projectile commonality drives lower through-life cost

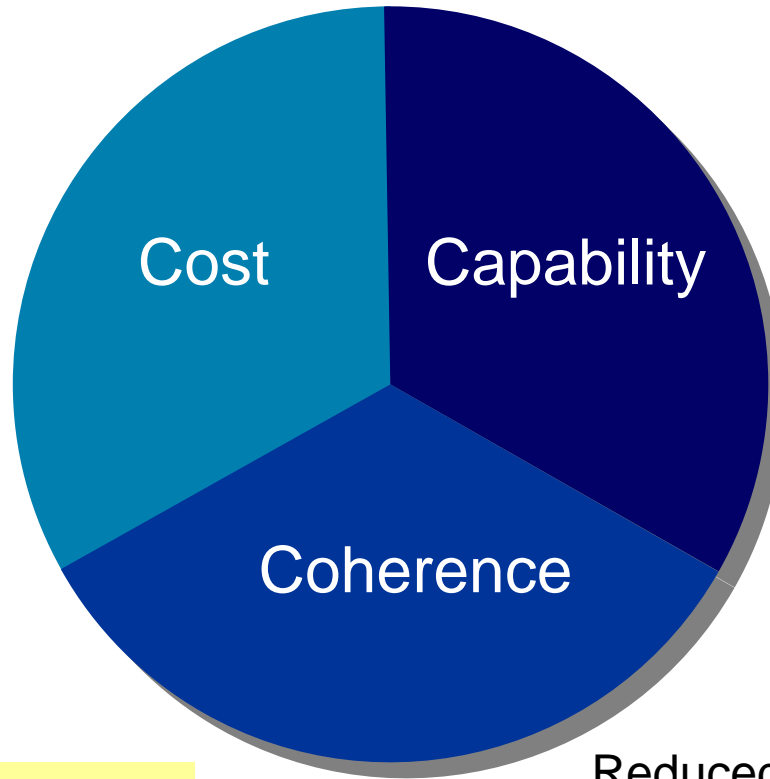

155mm target effect
Long range
Light weight
Growth potential

Provides an affordable enhancement in capability with low through-life costs. Commonality enables a coherent strategy for land and naval fires

Reduced logistics burden
Exploit land investment
Joint development opportunities

155TMF Current Programme

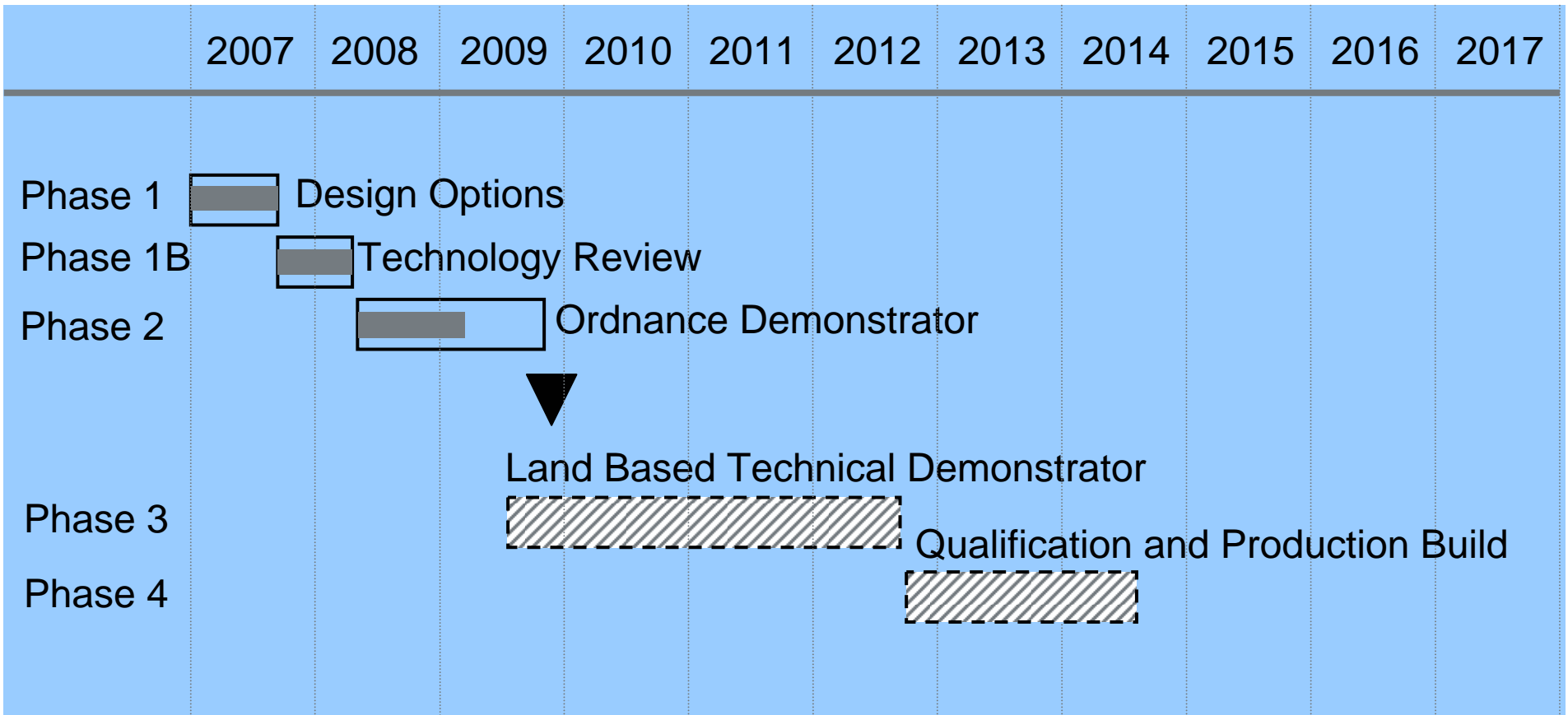

Contract through the UK MoD Defence Technology and Innovation Centre
Main stakeholder: Director of Equipment Capability (Above Water Effects)

155mm Naval - Future Coastal Suppression Study

- 155mm Weapon System
- Ammunition Handling
- Retained Structures
- Ship Installation
- Risk Reduction Prototype



155mm Naval - Future Coastal Suppression Study

- 155mm WEAPON SYSTEM
 - Ordnance Automation

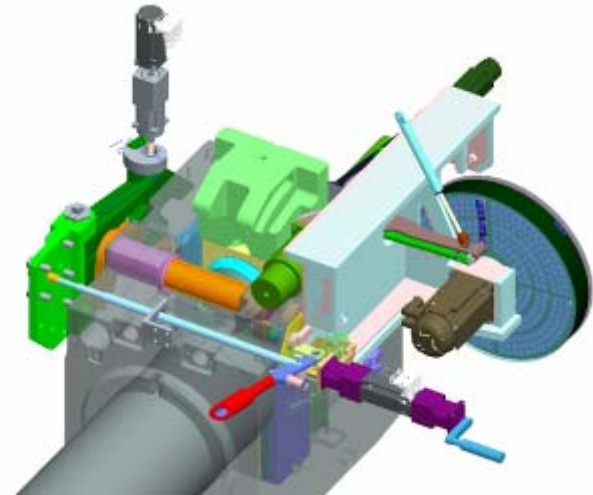
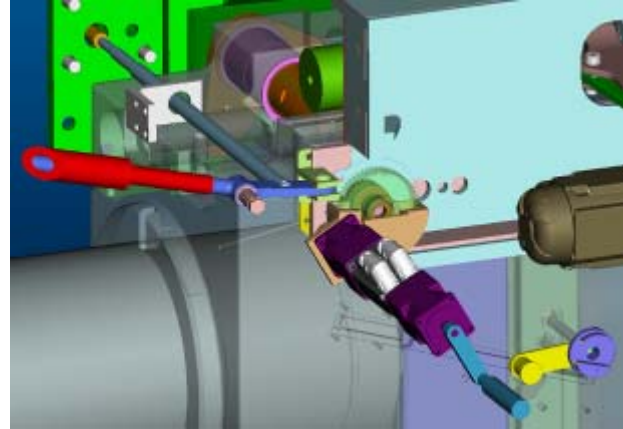

155mm Naval - Future Coastal Suppression Study

- 155mm Weapon System
 - Ordnance Automation
 - Charge Ignition

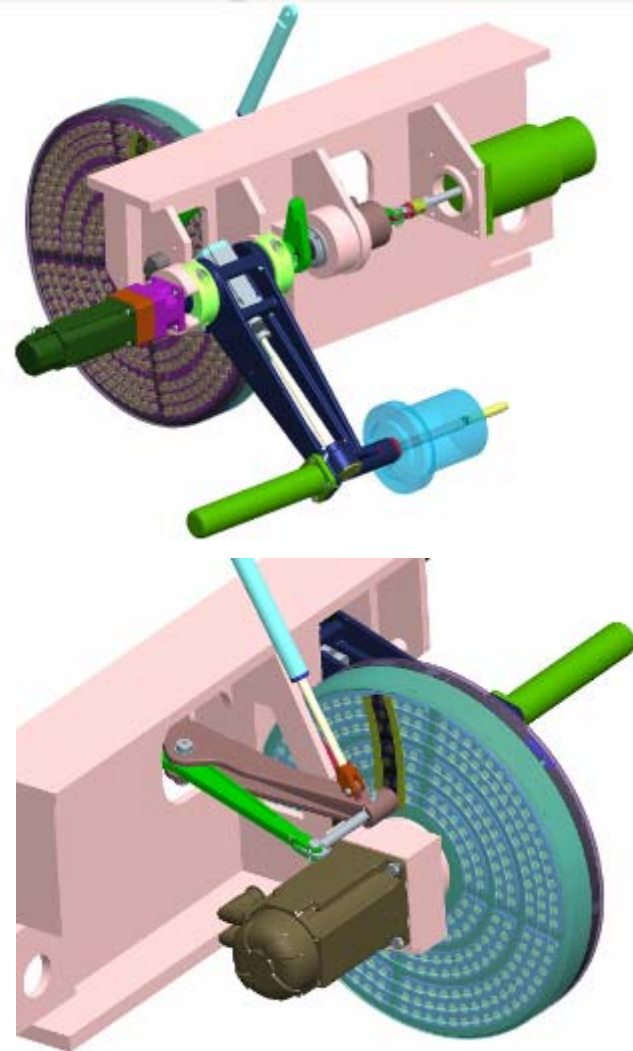
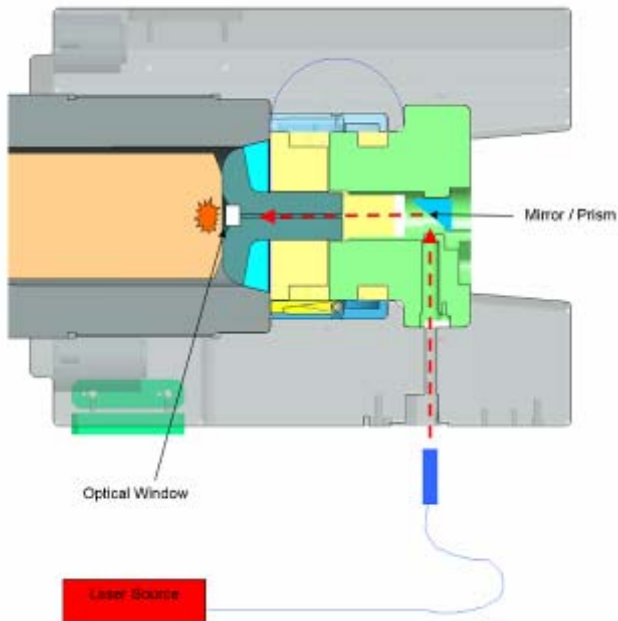

155mm Naval - Future Coastal Suppression Study

- 155mm Weapon System
 - Ordnance Automation
 - Charge Ignition
 - Cradle Design

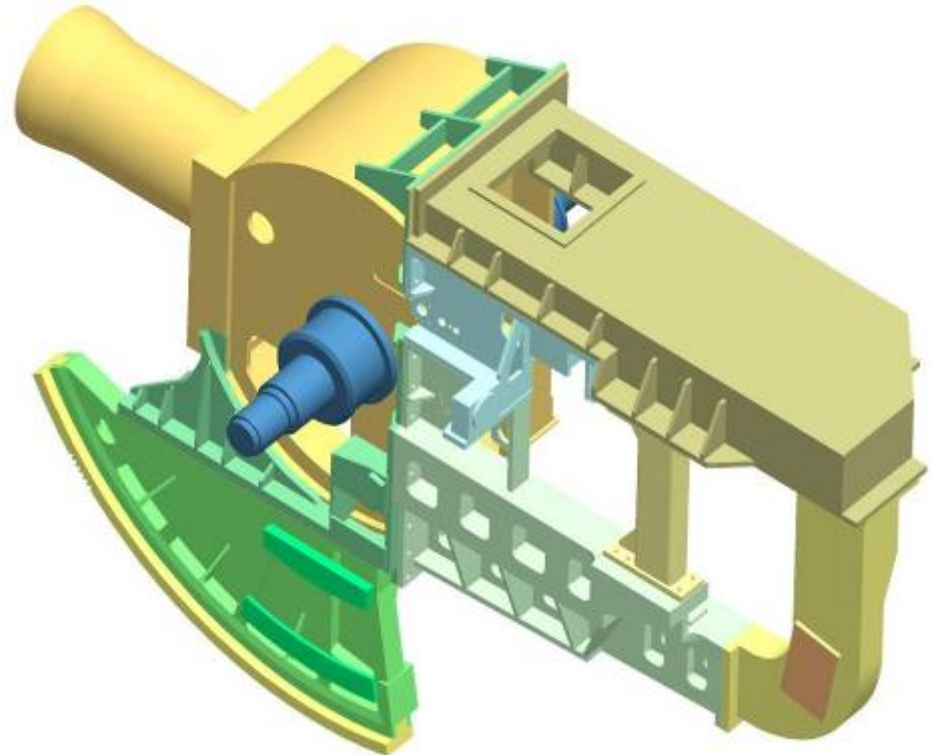

155mm Naval - Future Coastal Suppression Study

- 155mm Weapon System
 - Ordnance Automation
 - Charge Ignition
 - Cradle Design
 - Balance System

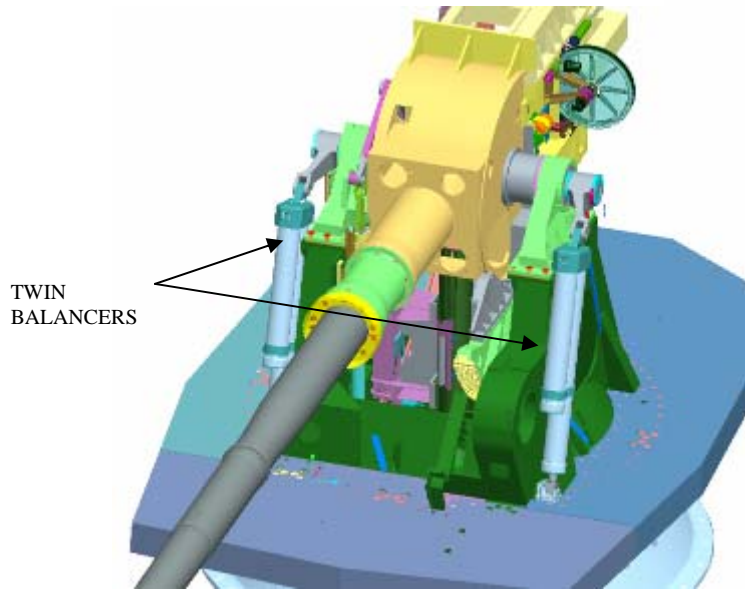
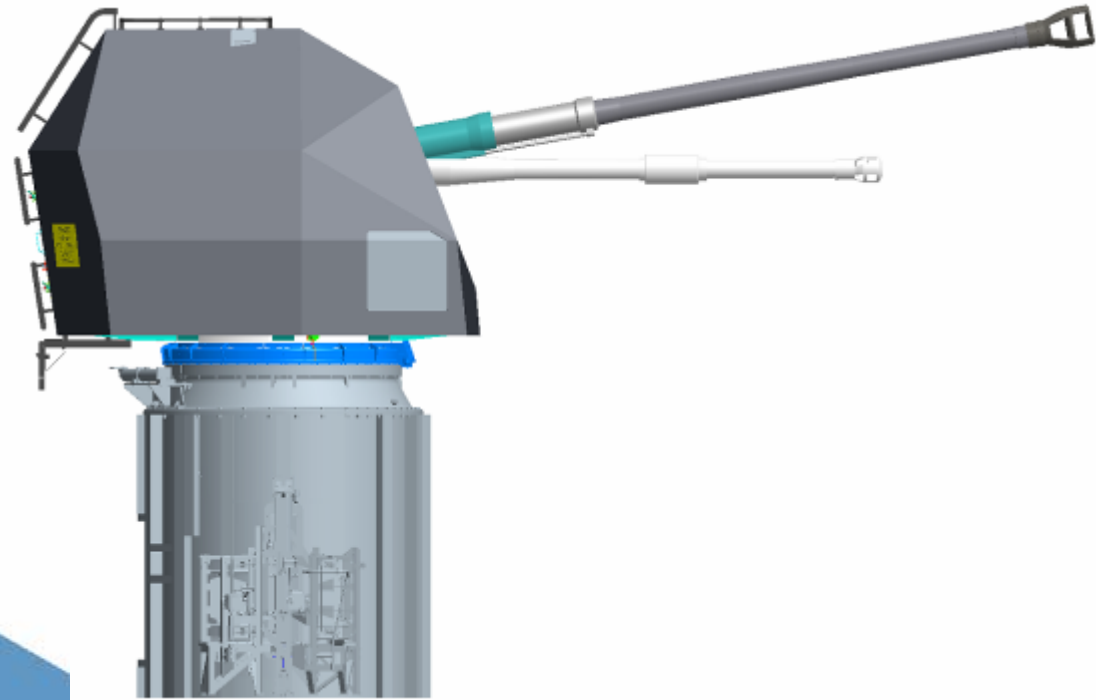

155mm Naval - Future Coastal Suppression Study

- 155mm Weapon System
 - Ordnance Automation
 - Charge Ignition
 - Cradle Design
 - Balance System
 - Recoil System

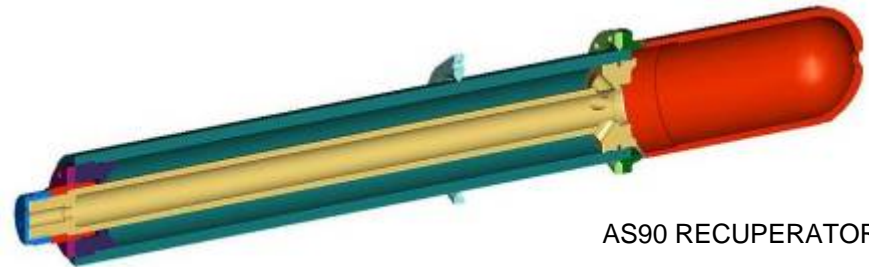

155mm Naval - Future Coastal Suppression Study

- 155mm Weapon System
 - Ordnance Automation
 - Charge Ignition
 - Cradle Design
 - Balance System
 - Recoil System
 - Elevation & Training Drives

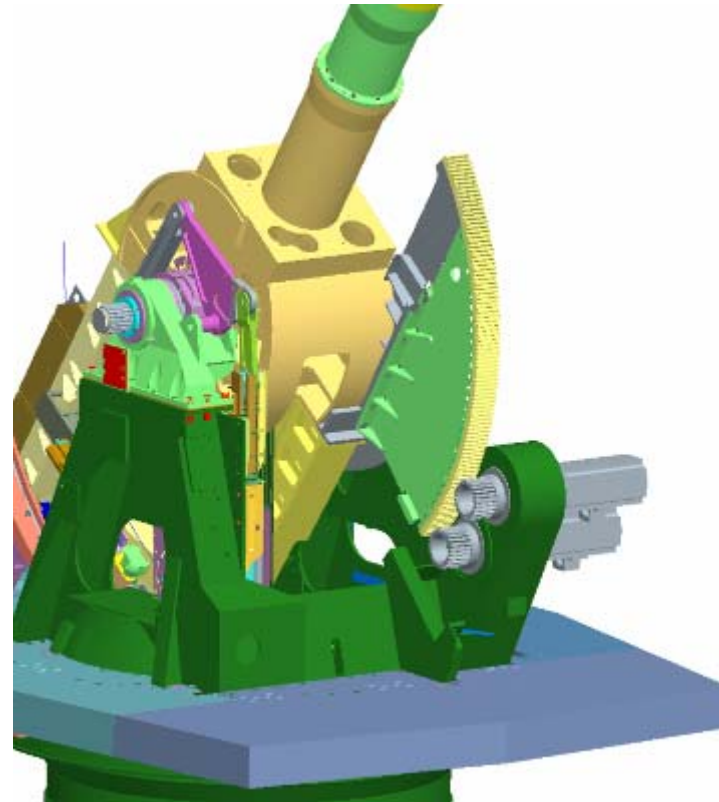

155mm Naval - Future Coastal Suppression Study

- 155mm Weapon System
 - Ordnance Automation
 - Charge Ignition
 - Cradle Design
 - Balance System
 - Recoil System
 - Elevation & Training Drives
 - Thermal Management

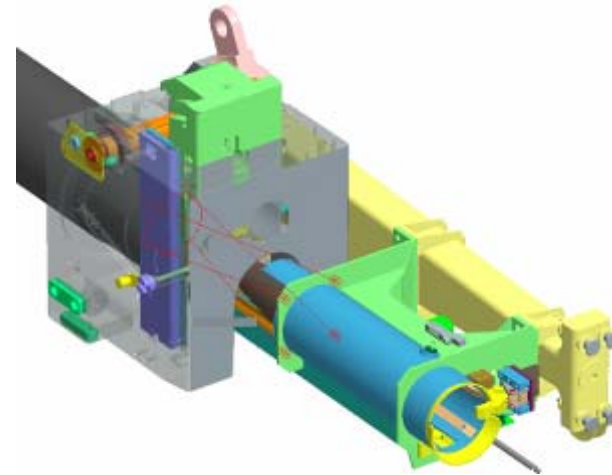

Pulse Bore Spray Arrangement

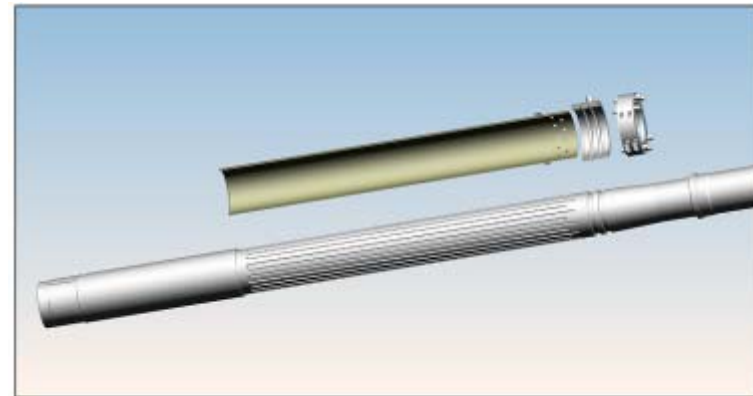

Grooved Barrel with Cooling Sleeve

Barrel Thermal Management



155mm Naval - Future Coastal Suppression Study

- Ammunition Handling
 - Feeding

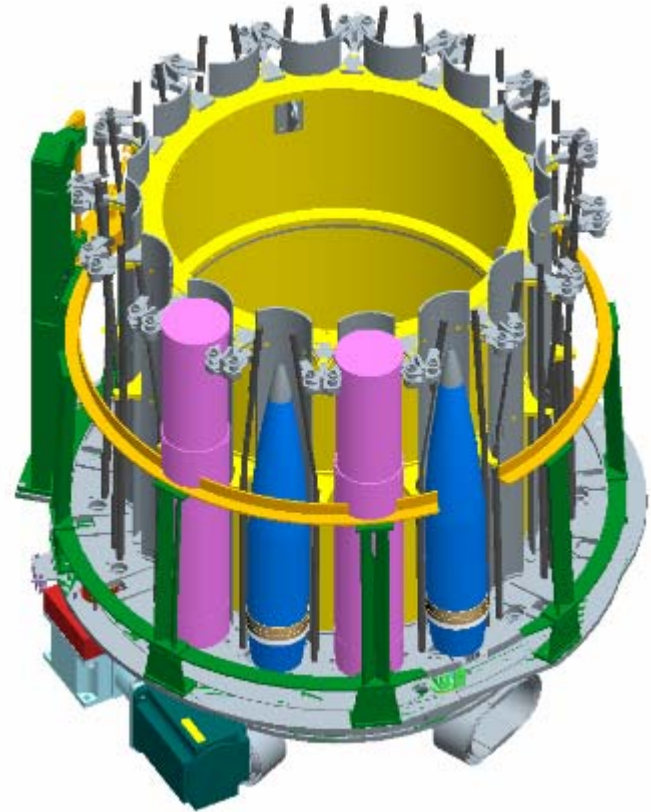

155mm Naval - Future Coastal Suppression Study

- Ammunition Handling
 - Feeding
 - Hoist

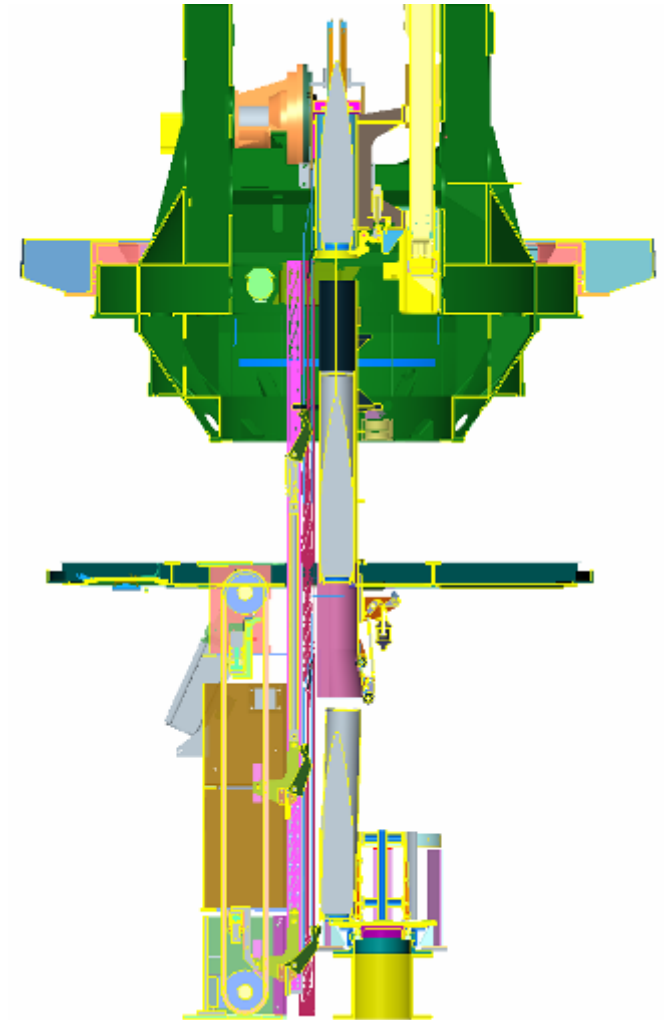

155mm Naval - Future Coastal Suppression Study

- Ammunition Handling
 - Feeding
 - Hoist
 - Loading Arm

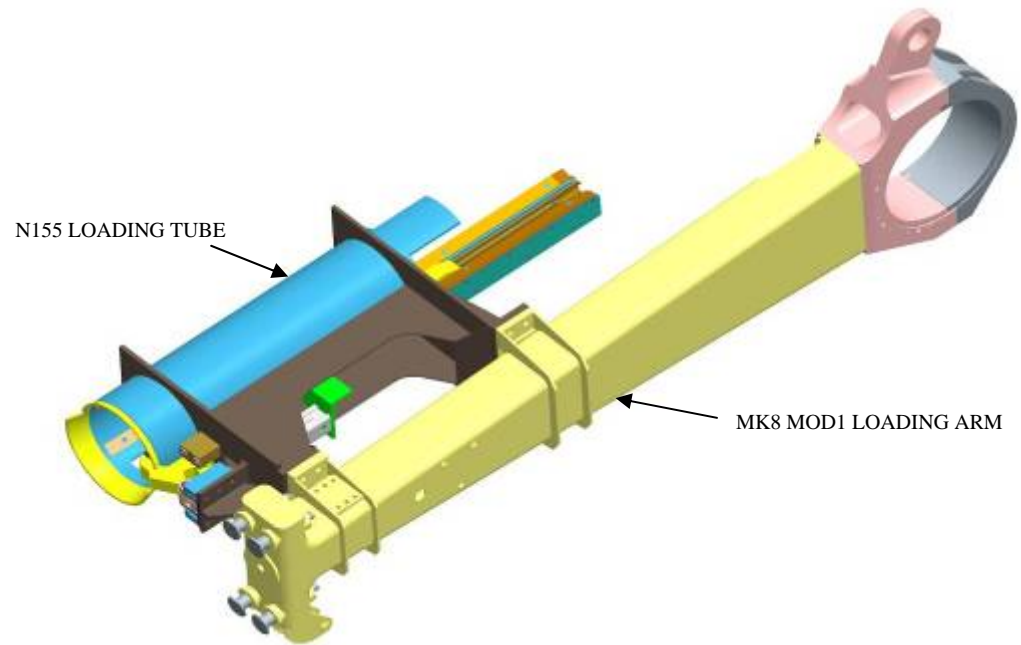

155mm Naval - Future Coastal Suppression Study

- Ammunition Handling
 - Feeding
 - Hoist
 - Loading Arm
 - Rammer System

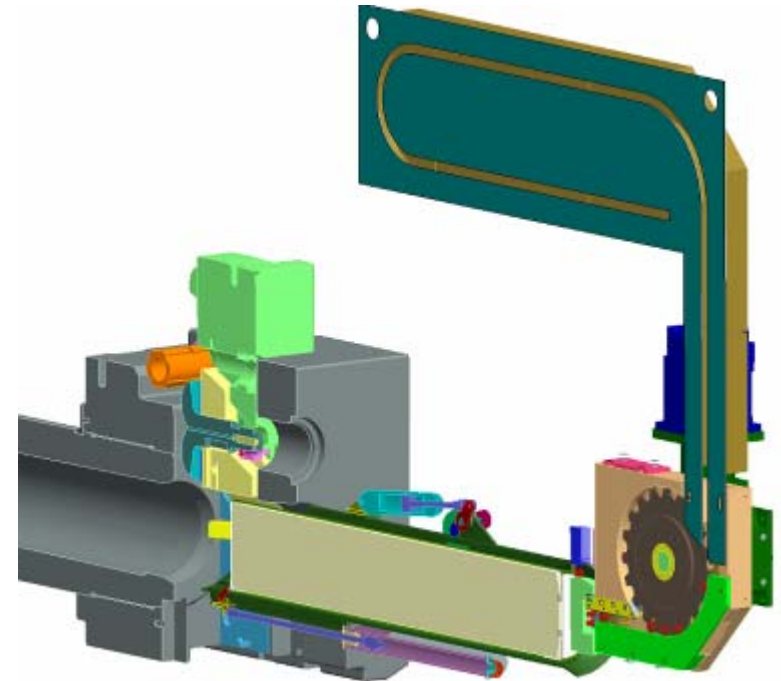

155mm Naval - Future Coastal Suppression Study

- Ammunition Handling
 - Feeding
 - Hoist
 - Loading Arm
 - Rammer System
 - Charge Retention

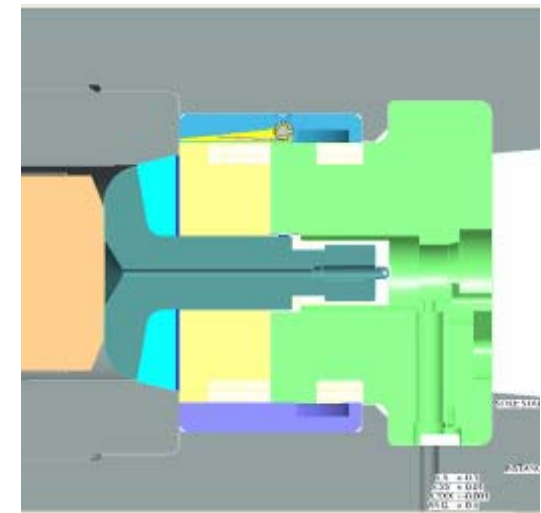
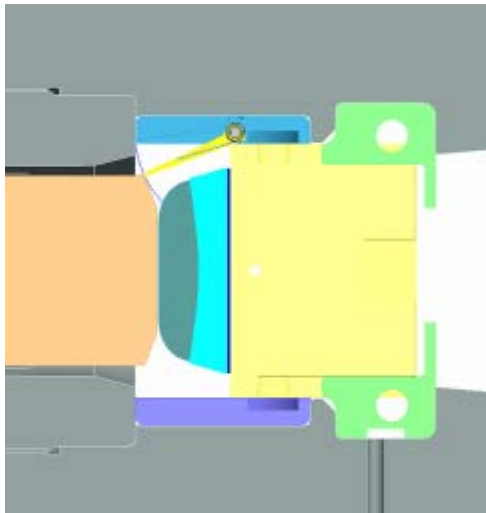
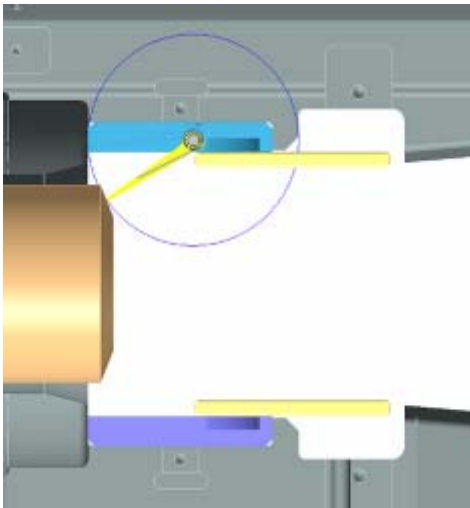

155mm Naval - Future Coastal Suppression Study

- Ammunition Handling
 - Feeding
 - Hoist
 - Loading Arm
 - Rammer System
 - Charge Retention
 - Charge Protection Case

PROTOTYPE CPC ASSEMBLY



CASE

CHARGE

PISTON

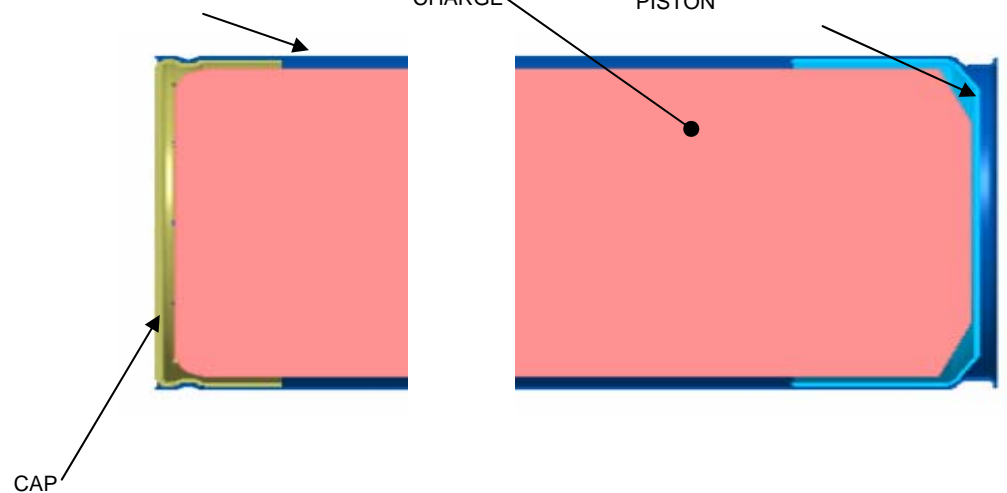

155mm Naval - Future Coastal Suppression Study

- Ammunition Handling
 - Feeding
 - Hoist
 - Loading Arm
 - Rammer System
 - Charge Retention
 - Charge Protection Case
 - CPC Ejection

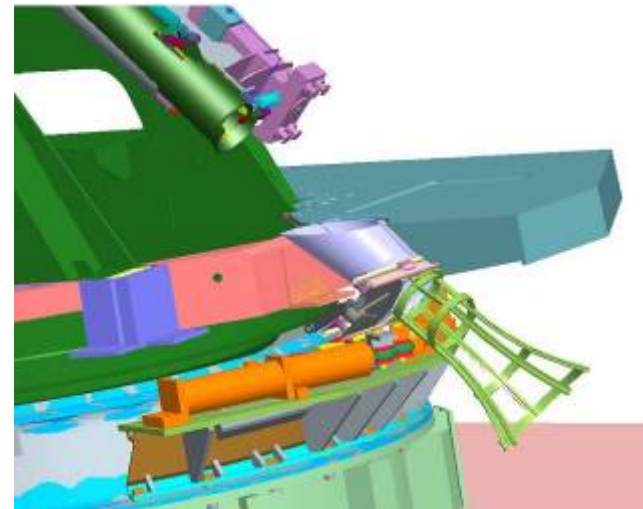
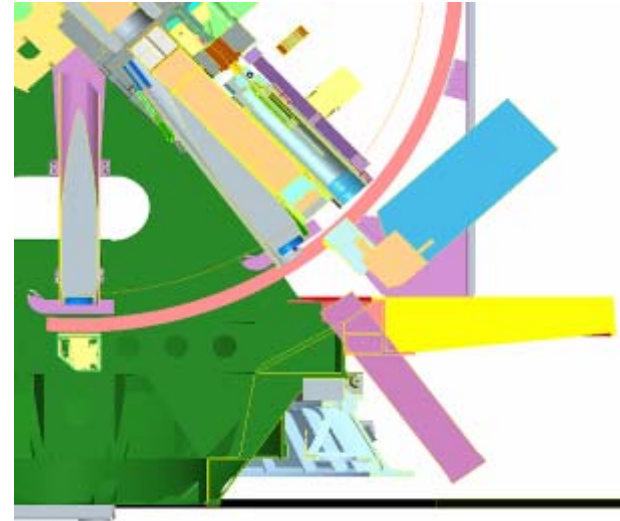

155mm Naval - Future Coastal Suppression Study

- Ammunition Handling
 - Feeding
 - Hoist
 - Loading Arm
 - Rammer System
 - Charge Retention
 - Charge Protection Case
 - CPC Ejection
 - Rammer Test Rig

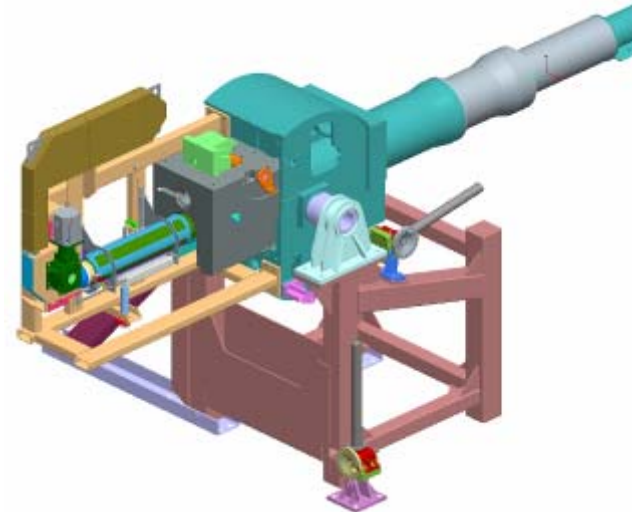



155mm Naval - Future Coastal Suppression Study

- Ship Installation
 - Type 23 Ship Structural Interfaces
 - Minor reinforcement
 - Type 45 Ship Structural Interfaces
 - Minor reinforcement and minor structural stiffening
 - Electrical System Modifications
 - Additional control and drive systems defined and power requirements estimated
 - Harmonic limits for ships supply met
 - Fire Control Interfaces
 - Ballistic calculations can be updated
 - Capacity available to control future intelligent munitions
 - Existing system interfaces will allow integration with wider battlefield command and control systems

Key Success Factors

Need to demonstrate value for money vs. “do nothing” option (Mk 8 4.5”)

- Development and Qual
- UPC
- Integration Cost
- Through Life Support

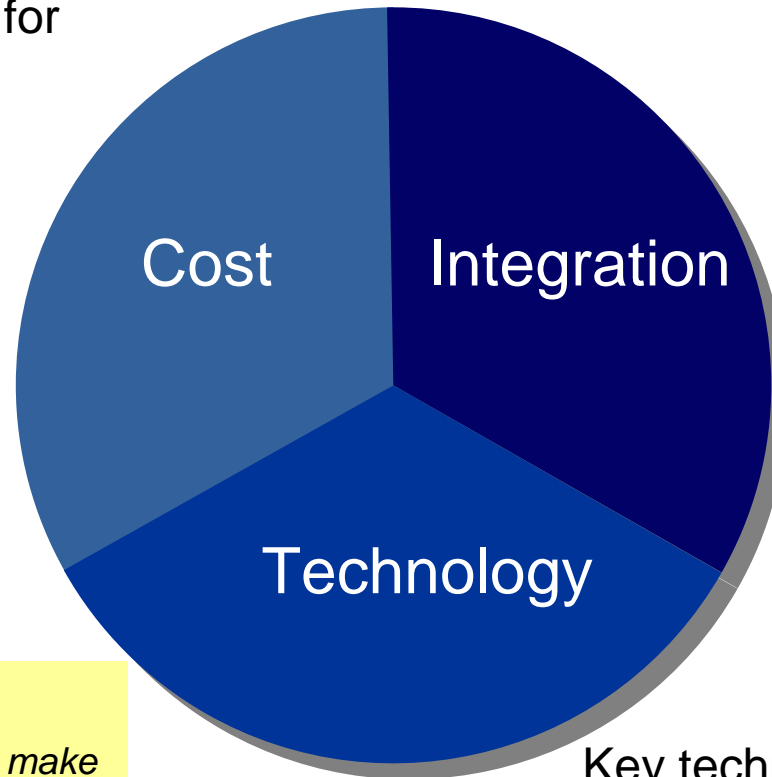

Key integration aspects

- Ship Installation
- Fire Control
- Ammunition Stowage and Handling
- Land / Maritime Coherence

Wider Strategic Aims

- *Support Home Market strategy: make wider BAE expertise available to the customer through UK business unit*

Key technical areas

- Ordnance Automation
- Dual Stroke Rammer
- Thermal Management

Key Success Factors

Need to demonstrate value for money vs. OTS options and "do nothing" option (4.5")

- Develop
- UPC
- Integrati
- Through

Key Risk Area For TMF

- **Raised in Options Report for FSC**
- **Not included in UK MoD research contract**
- **Ship builders require information to support PV Programmes**
- **Core Capability of US Combat Systems**
- **So What?**

Wider Strategic

- Support Ho
- wider BAE
- customer t

- **W&V PV committed in 2007 & 2008**
- **Report passed to UK MoD and Naval Design Partnership**

Key integration aspects

- Ship Installation
- Fire Control
- **Ammunition Stowage and Handling**
- Land / Maritime Coherence

- technical areas
- Ordnance Automation
- Dual Stroke Rammer
- Thermal Management

Future Work

- Research test programme 2009
 - Ordnance firing demonstrator
 - Demonstrate strength of design
 - Dual full stroke rammer test rig demonstration
 - Thermal management test rig
 - Model validation
 - Laser Ignition demonstration
- Land based Integrated Demonstrator 2009 – 2011
 - Integration of ordnance and ammunition handling
 - Demonstrate system and technology maturity
- Full development 2011 – 2014



155 TMF Summary

- 155TMF is design that integrates the AS90 155mm ordnance with the Mk8 Naval Gun
- Key Attributes
 - Enhanced capability
 - Affordable through-life cost
 - Land and Naval fires coherence
- UK funded research programme to inform the Future Surface Combatant requirements
 - Mitigating technology risk
 - Excellent progress to date



Questions

