



# **Interagency Improvised Explosive Device Defeat**

**Dr. Edwin A. Bundy  
Program Manager  
TSWG Improvised Device Defeat Subgroup and  
EOD/LIC Program**



**Combating Terrorism Technical Support Office**



# EOD/LIC Mission

The Explosive Ordnance Disposal/Low-Intensity Conflict (EOD/LIC) program provides Joint Service EOD technicians and Special Operations Forces (SOF) operators with the advanced technologies and mission-focused solutions required to address current and emerging threats presented by unconventional and asymmetric warfare.





# Remote Operations and Advanced Mobility

- Develop capabilities to remotely approach, enter, and conduct reconnaissance operations in hazard areas and danger zones.
- Enhance mobility-related technologies and equipment to facilitate safely approaching, operating in, and withdrawing from hazardous environments.
- Develop systems and technologies to gather and store operational information for transmission to operational personnel and unit commanders.
- Improve technologies for the relocation of unexploded ordnance, hazardous materials, and improvised devices.





# Remote Operations and Advanced Mobility







# Access and Disablement

- Develop tools to quickly and efficiently breach or gain access to structures, barriers, vehicles, and containers
- Develop chemical, mechanical, electrical, and explosively actuated systems for the neutralization and disruption of unexploded ordnance and improvised devices
- Improve technologies for rendering fuzing and firing systems inoperable





# Access and Disablement

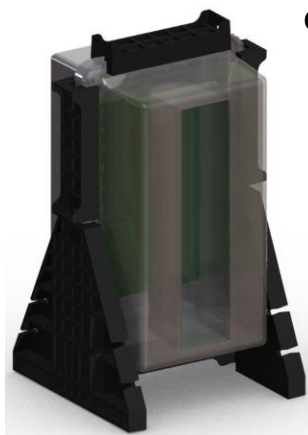
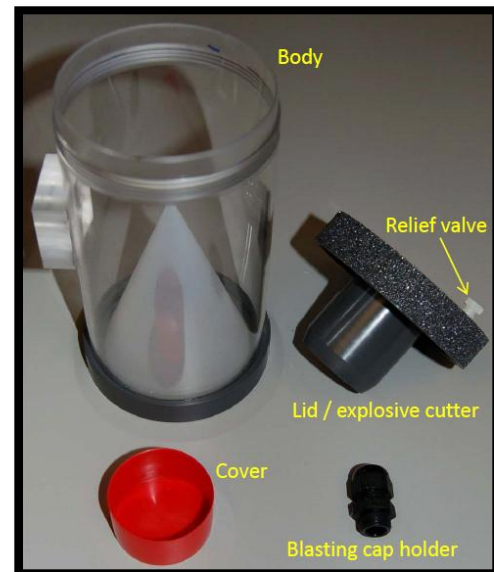

Cross-Section, 100  $\mu$ s

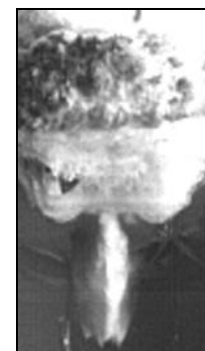
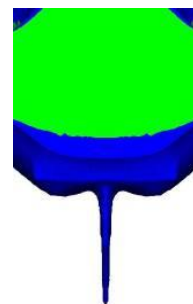



# Detection, Diagnostics, and Analysis

- Develop tools to locate and verify the presence of improvised devices, unexploded ordnance, booby traps, and other threats
- Develop technologies to determine the specific type, condition, and characteristics of unexploded ordnance and improvised device components, and the specific hazards associated with each
- Improve methods to analyze and evaluate improvised device construction







# Detection, Diagnostics, and Analysis







# Protective Measures and Effects Mitigation

Advance the development of personnel protection systems for operations in enhanced hazard environments. Develop novel and improved solutions to protect personnel and property from blast, fragmentation, and ballistic hazards.





# Sustainability and Operations Management

- Develop tools and equipment to enhance situational awareness and operational capability during incident response or direct action operations
- Develop human performance improvement tools that foster the advancement of knowledge related to unexploded ordnance, improvised devices, and hazardous environments
- Develop tools and training for conducting novel and advanced missions related to improvised devices and hazardous environments.





# Sustainability and Operations Management





# IDD Mission

Identify, prioritize, and execute research and development projects that satisfy mission critical needs, fill capability gaps, and address interagency requirements for advanced technologies to safely and effectively defeat improvised terrorist devices. Emphasis is placed on technologies to enhance the training and support of operational personnel in the location, identification, render safe, and disposal of homemade explosives, improvised explosive devices, and other emerging terrorist threats.







# Research Challenges

- In December 2008, the D-IED SC published, Research Challenges in Combating Terrorist Use of Explosives in the United States
- The report outlines ten challenge areas where concentrated research can be most beneficial in combating IED use in the homeland

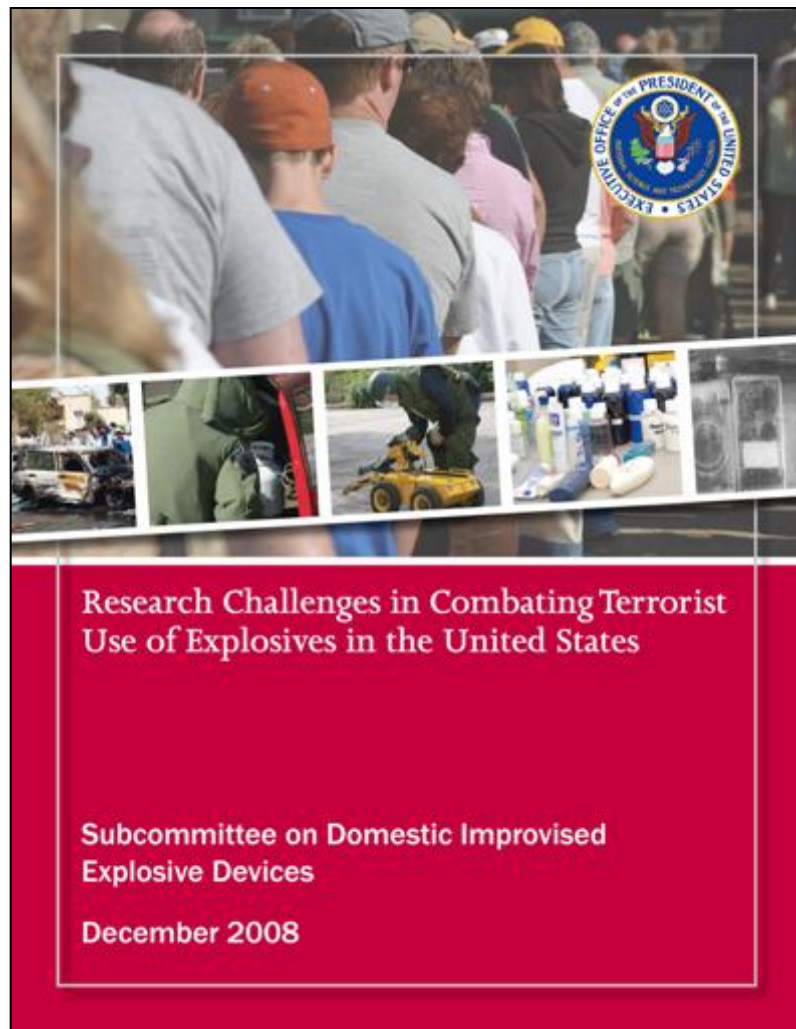



# Research Challenges

- C-IED Network Attack and Analysis
- Detection of Homemade Explosives
- Standoff Rapid Detection of Person Borne IEDs
- Vehicle-borne IED Detection
- IED Access and Defeat
- Radio Controlled IED Countermeasures
- IED Assessment and Diagnostics
- Waterborne IED Detect and Defeat Systems
- IED Threat Characterization and Signatures
- IED Warnings





# Device Defeat

- Develop advanced technologies to defeat the broad spectrum of improvised terrorist devices to include improvised explosive devices (IEDs), vehicle borne IEDs (VBIEDs), person borne IEDs, and enhanced hazard devices containing chemical, biological, or radiological materials
- Develop innovative, cost-effective disruption and precision render safe solutions that increase standoff distance, reduce collateral damage, and decrease risk to the improvised devices defeat operator
- Improve neutralization techniques for both sensitive and insensitive explosives and enhanced payloads such as flammable liquids and gases.







# Device Defeat

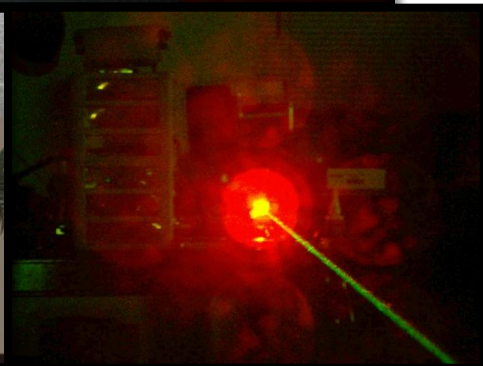
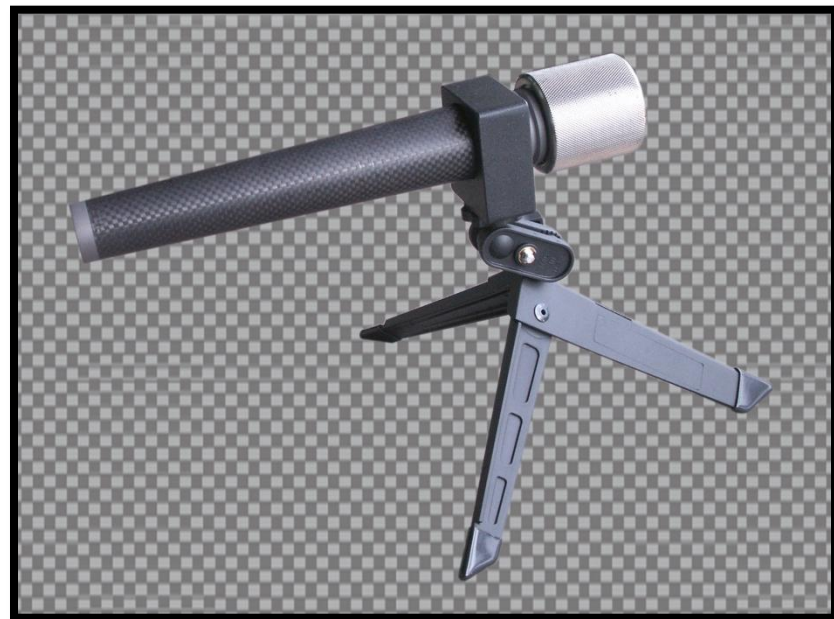





# Identification and Diagnostics

- Advance the capability of bomb technicians to interrogate unknown or suspect items and packages
- Develop technologies to locate and identify improvised devices and enhanced fillers, and diagnose key fuzing and firing components
- Develop tools to assist bomb technicians in the identification of U.S. and non-U.S. ordnance and firing systems incorporated into or modified for use in improvised devices





# Identification and Diagnostics

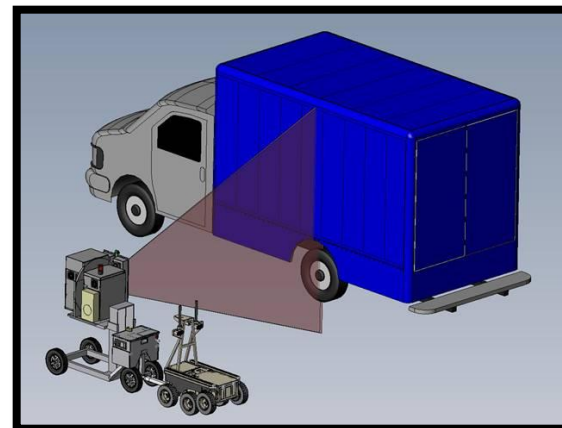



# Emerging Threats

- Advance production of effective countermeasures to neutralize or defeat radio-controlled IEDs and provide safe environments for bomb technicians
- Develop, characterize, and test technology solutions to safely and effectively render safe or neutralize devices containing improvised homemade explosives
- Develop, characterize, and test technology solutions to effectively render safe improvised devices using novel fuzing systems that incorporate such items as an electronic sensor, microcontroller, or mechatronic components







# Emerging Threats



LAW ENFORCEMENT SENSITIVE

Performance Assessment of Electronic Countermeasures Against Selected Remote Controlled Improvised Explosive Devices

Final Report  
September 2005

Prepared for:  
Technical Support Working Group

LAW ENFORCEMENT SENSITIVE

LAW ENFORCEMENT SENSITIVE

Compatibility Assessment of Electronic Countermeasures with United States State and Local Law Enforcement Bomb Squad Equipment

Final Report  
December 2005

Prepared for:  
Technical Support Working Group

LAW ENFORCEMENT SENSITIVE







# Remote Procedures

- Develop advanced application systems to remotely access, diagnose, and defeat improvised devices
- Advance development of manufacturer and model-independent products and robotic tools with “plug and play” interface
- Develop open-architecture, navigation, communication, and operator controls for robotic platforms, tools, and sensors.





# Remote Procedures

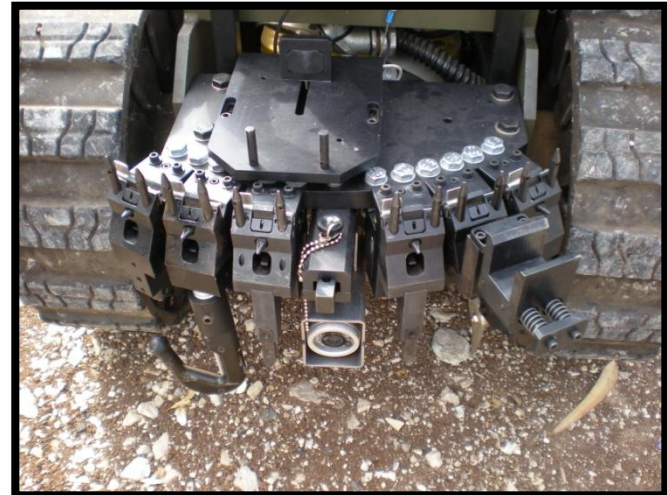



# Tool Characterization and Information Resources

- Improve performance evaluation methodologies, test procedures, and tool characterization models for improvised device defeat technologies
- Conduct ongoing evaluation and improvement of tools, methods, and protocols for confirming the accuracy of detection equipment, reliability of diagnostic tools, and completeness of neutralization and safeing techniques
- Advance training concepts and information delivery systems that promote the tactical and operational response readiness required to effectively, safely, and efficiently counter improvised devices and emerging terrorist threats







# Tool Characterization and Information Resources

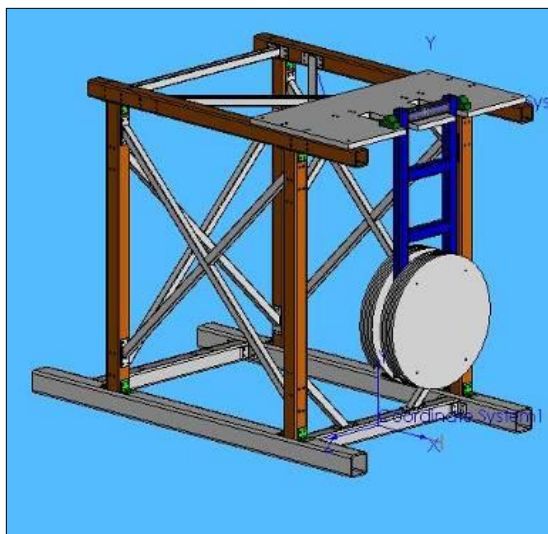
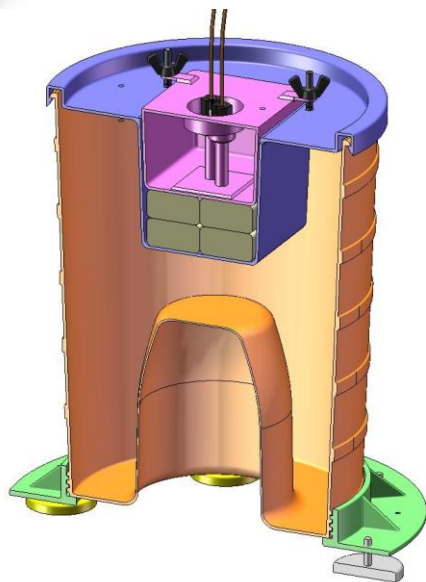





# Maritime Security and Water-Borne IEDs

- Develop technologies to protect ships, boats, docking facilities, offshore platforms, shore-side loading facilities, power plants, bridges, and marine cables and pipelines from any form of terrorist attack





# Maritime Security and Water-Borne IEDs

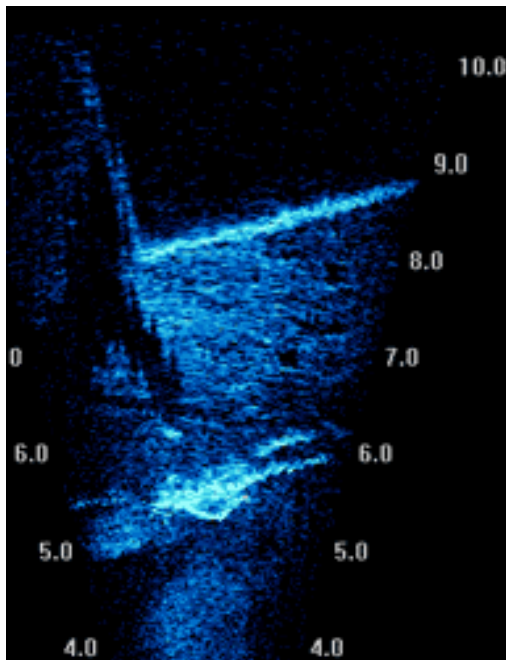

**DIDSON Sonar**



**Modular Unmanned  
Surface Craft-Littoral  
(MUSCL)**





# Summary

- User-focused approach to IED Defeat
- Seeking participation from other government agencies
- Solutions for both military and civilian bomb technicians
- Leveraging interagency and international contributions

## **Contact information:**

[eodlic@eodlic.cttso.gov](mailto:eodlic@eodlic.cttso.gov)

[iddsubgroup@tswg.gov](mailto:iddsubgroup@tswg.gov)

