

UTRON



“Lightening Strike” – An Indirect Fire Concept Utilizing Combustion Light Gas Gun (CLGG) Technology to Achieve Extreme Ranges

David Kruczynski
Stephen G. Floroff

Workings of a Combustion Light Gas Gun

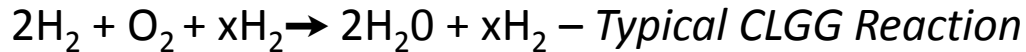

In the CLGG;

Oxygen quantity controls the available energy

Hydrogen serves both as a propellant and diluent

Hydrogen quantity controls the;

Sound Speed

Combustion Temperature

Molecular Mass

Key CLGG Benefits

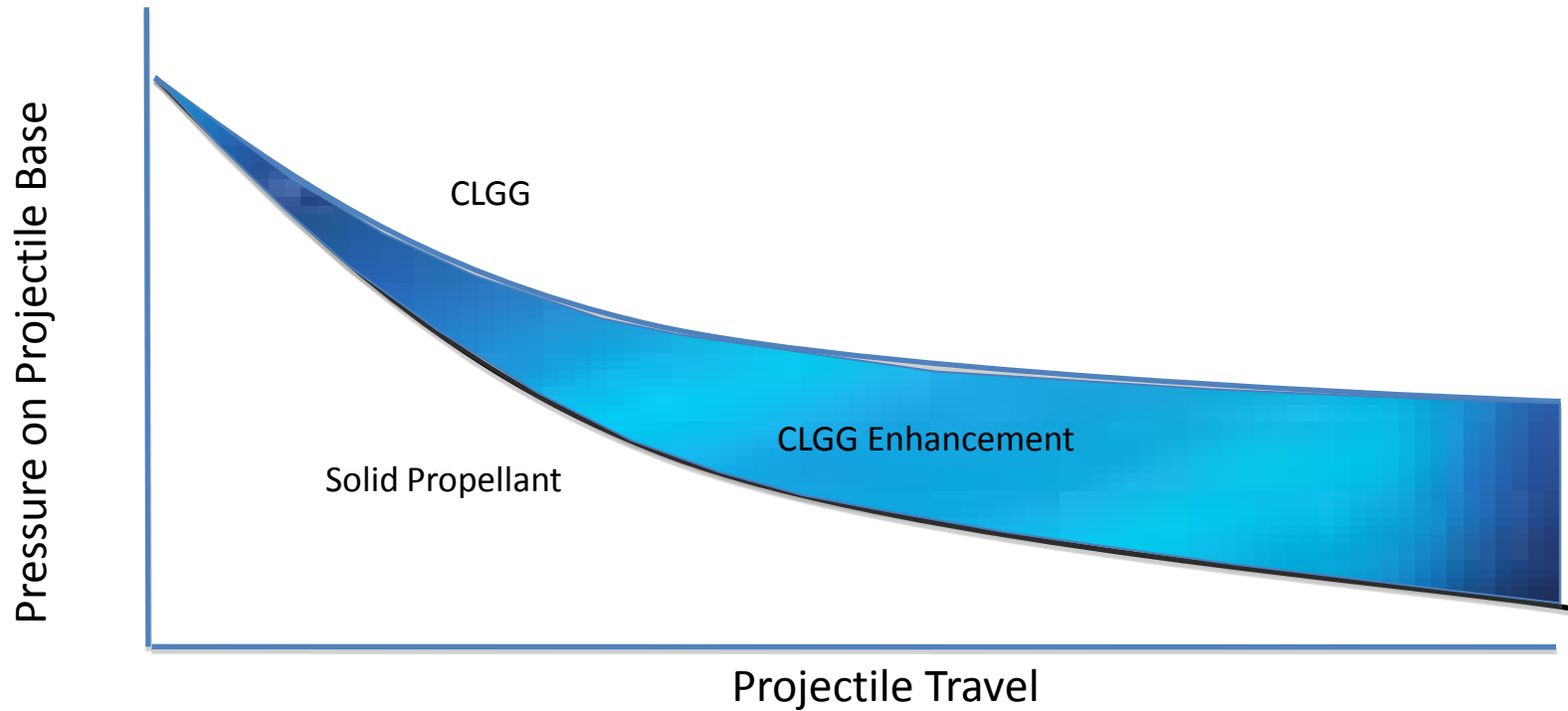

- Higher velocity and/or muzzle energy
- Zoning control
- Ability to produce propellant onsite

CLGG HISTORY

1993 -
16-mm ELGG - CLGG

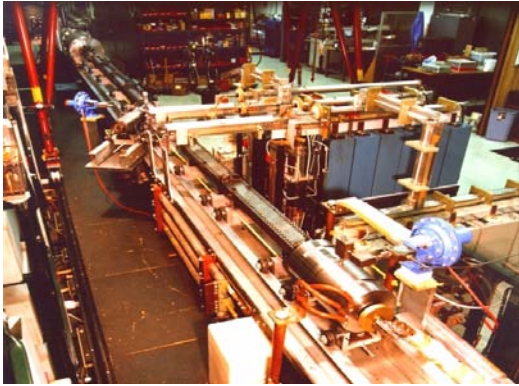

1995 -
45-mm CLGG



2007 -
155-mm CLGG



Indirect Fires Notional Concept

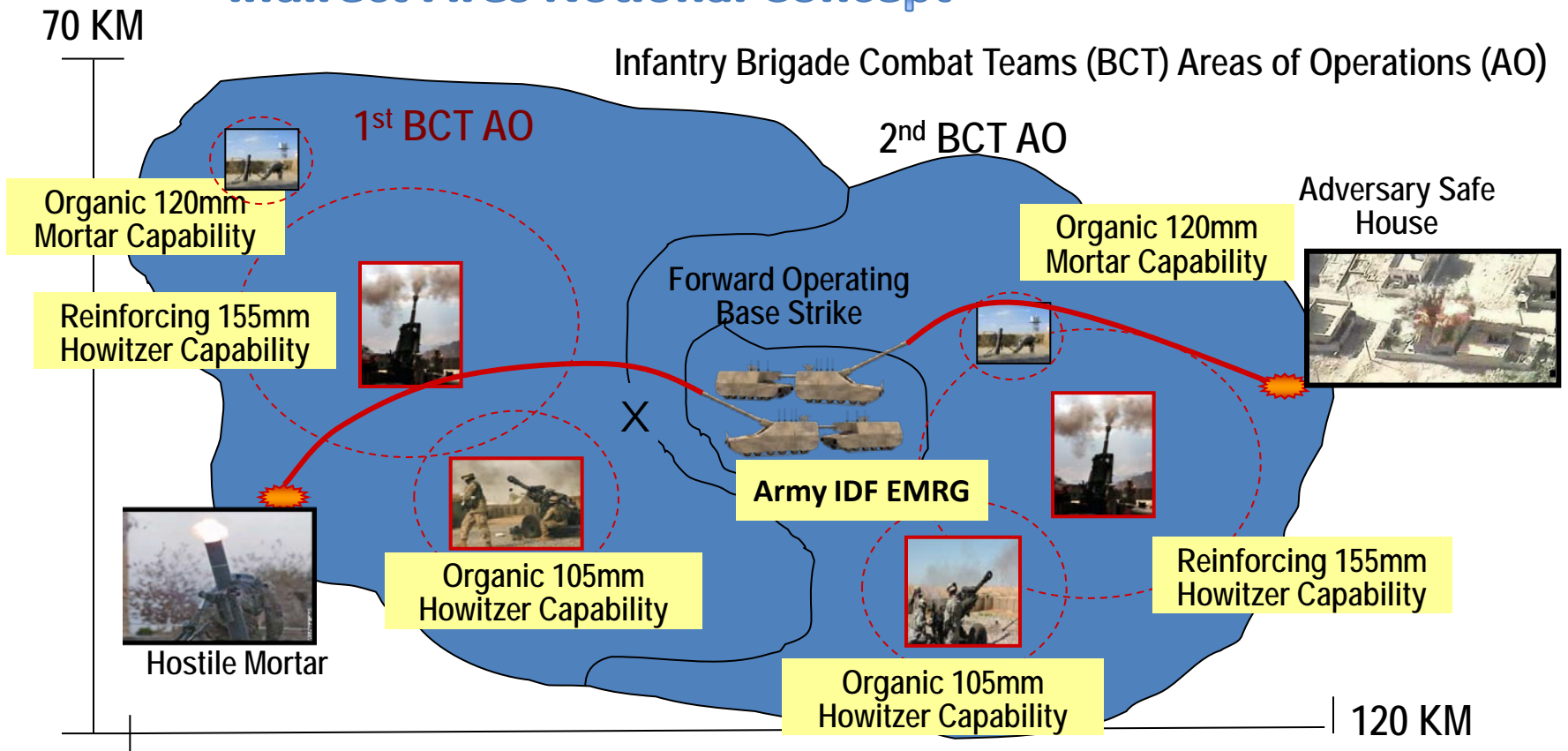

- Here's a notional concept of how we might change and expand the capabilities of indirect fires with EMRG.
- Shown are two U.S. Army infantry brigade combat teams areas of operation not unlike what we see in Afghanistan today
- The 105mm howitzer represents the range capability of that system. Today we place these units in sub-optimized pairs to allow coverage for the most critical areas of operation.
- There are obviously logistics and force protection challenges with each of these operating bases we are required to establish.
- The 120mm mortar has an even smaller area of coverage.
- Next we have shown what reinforcing 155mm howitzers add in terms of range capability.
- In the center of the area deployed on forward operating base Strike, a pair of Army indirect fire ERMGs are providing extended range, precision fires to the entire area to attack an enemy mortar firing in the east and an enemy safe house in the west.
- All of this from a very secure area that is easily sustainable.
- I hope this provides a snap shot of how EMRG can drastically change indirect fire capability in the future.

Artillery Technology Environment

Assumptions:

- Course correcting technology will become cheap and ubiquitous.
 - While one may debate how soon, how accurate and how cheap – this will occur over the course of the coming decade or two.
- Long range, time sensitive target location technology will come. It will include organic, local and inorganic i.e. global.
 - While many targets will undoubtedly remain elusive, dispersed and time critical communication of target location over vast areas will become common place over the coming decade or two.
- Scalable lethality will come. It will be demanded.
 - Flexibility with regard to the trade between lethality of effects and collateral damage will be achieved.

ARMY Use of CLGG Technology – Safety and Vulnerability

UTRON and others have extensively studied hydrogen and oxygen safety and vulnerability. Bottom line, is that these materials can be made as least as safe as the propellants and motors, which they replace, by well-understood engineering practices.



*Hydrogen Car on Left, Gasoline Car on Right
Both Tanks Punctured*

Fuel Ignited



ARMY Use of CLGG Technology – Projectile Considerations

CLGG technology is backward compatible with some projectiles in the current inventory such as the M549A1 round with minor modifications however, rounds specifically designed for higher velocity flight are suggested.

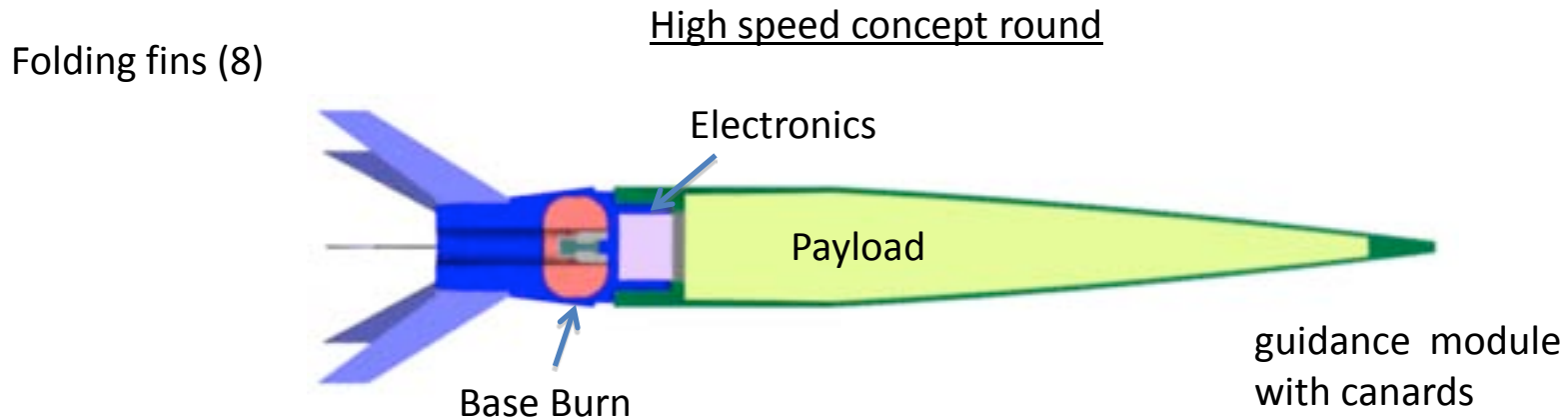
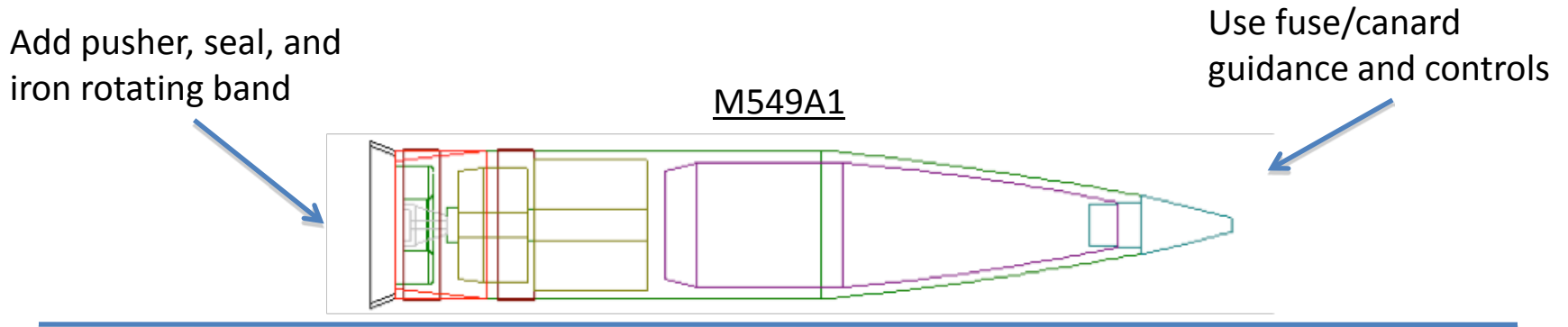

ARMY Use of CLGG Technology – Logistics

CLGG propellants are currently available from an established industrial base in the US and elsewhere. The ability to produce CLGG propellants onsite adds additional flexibility in logistics.

Major H₂ production sites in U.S.

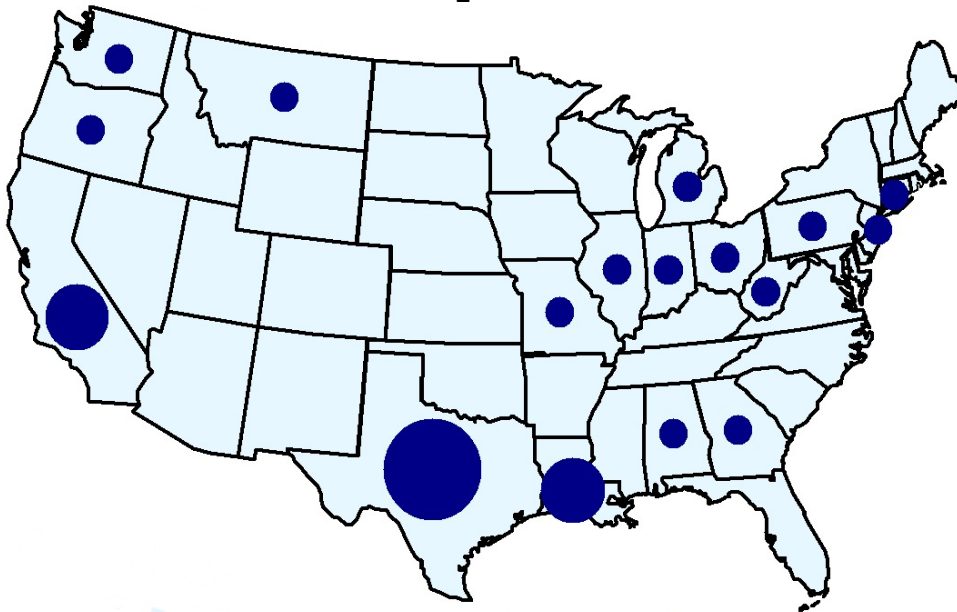

Industrial production and use of H₂

Area	Hydrogen gas Trillions ft ³	If Liquid Billions Gal
U.S.	4.2	35
Worldwide	25	210



In addition
onsite production
Is available as
needed



ARMY Use of CLGG Technology – Concepts

A 155mm tracked vehicle equipped with a 52 caliber long CLGG is capable of launching a 45 kg projectile to ranges up to 100 km.

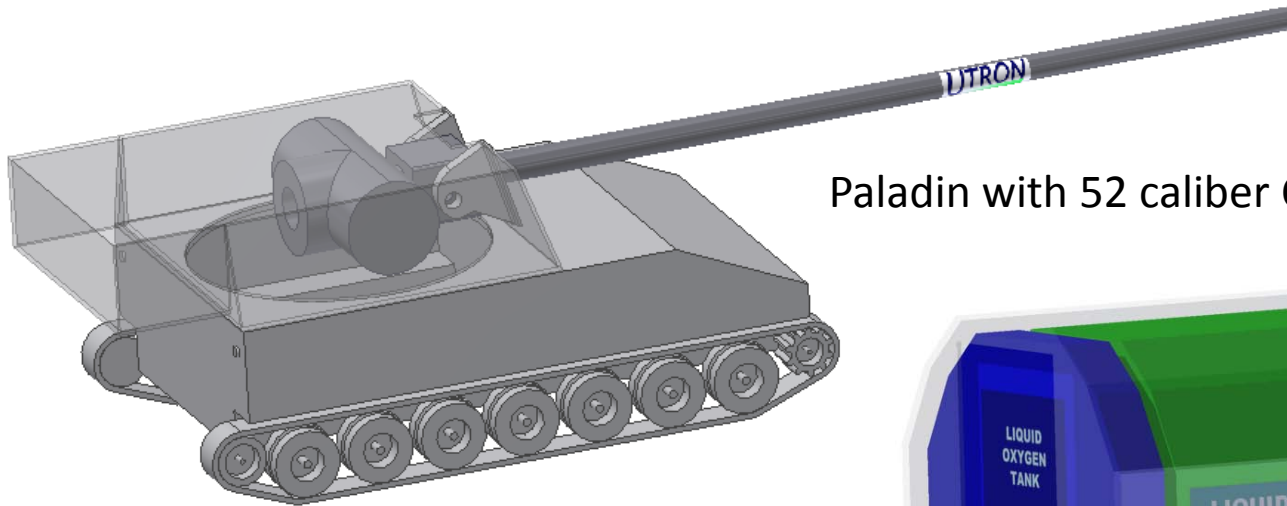

Paladin with 52 caliber CLGG



FAASV with CLGG Propellants

FAASV resupplying CLGG equipped Paladin

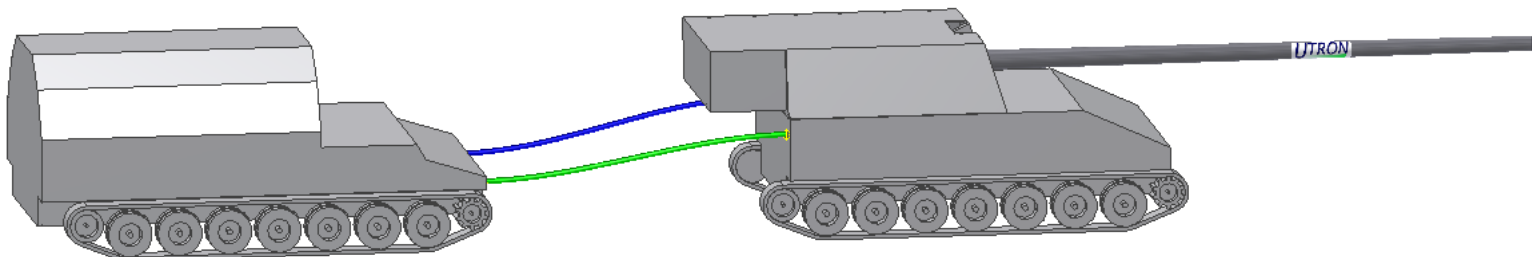

CLGG – Future (near term)

- ✧ Build Tracked Based CLGG Demonstrator
- ✧ Continue Logistics Studies
- ✧ Perform Onsite Production Demonstration



155-mm bore CLGG Firing