

TASK FORCE 278 ACR

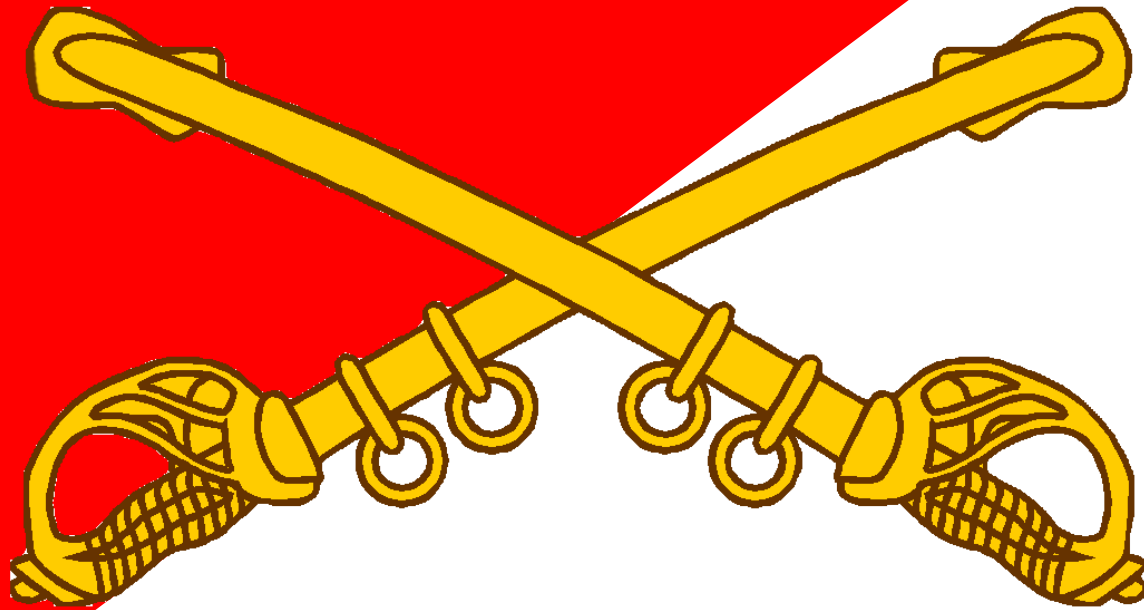

278TH ARMORED CAVALRY REGIMENT



Task Organization

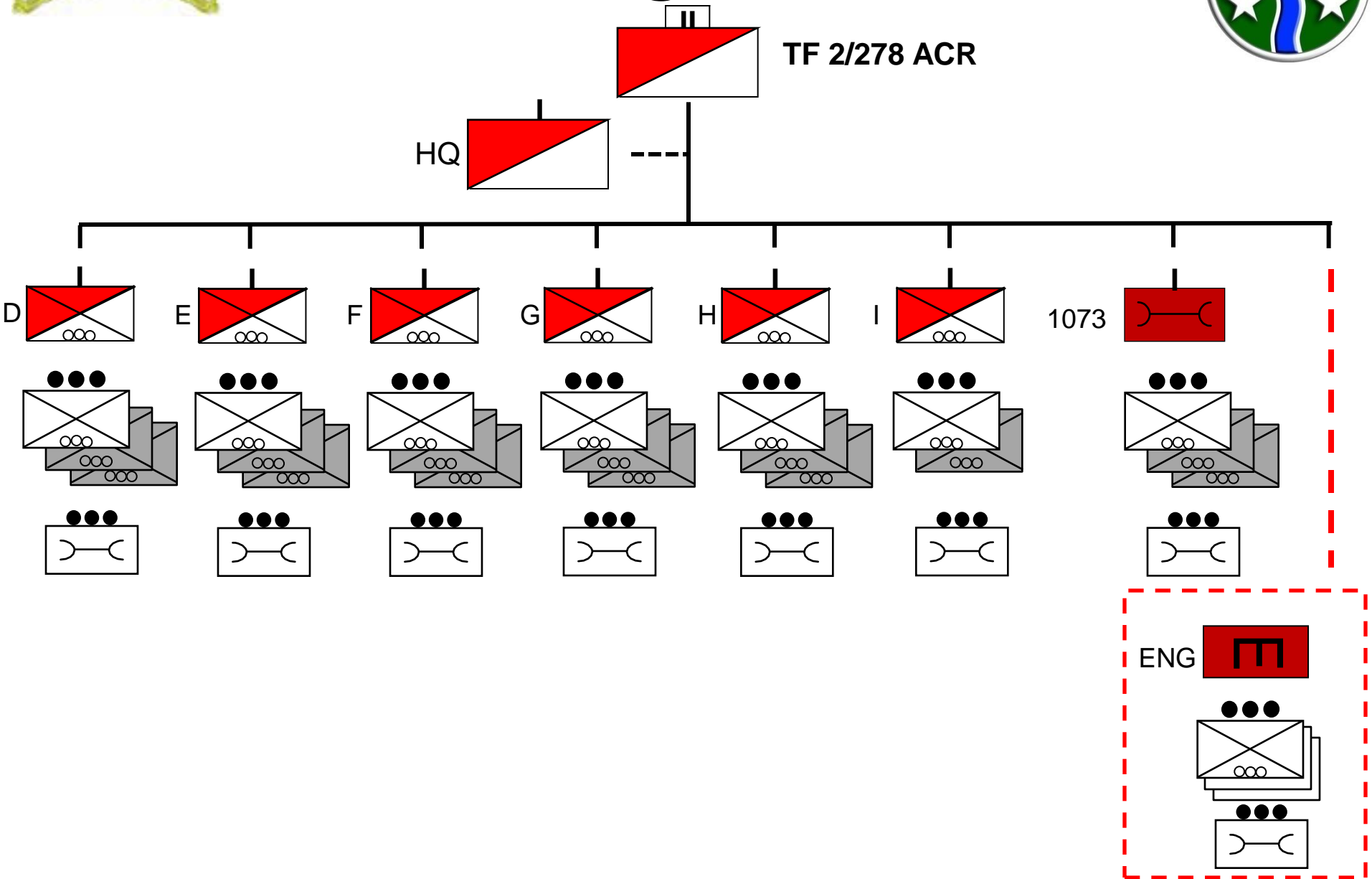

UNCLASSIFIED

AREA OF OPERATION

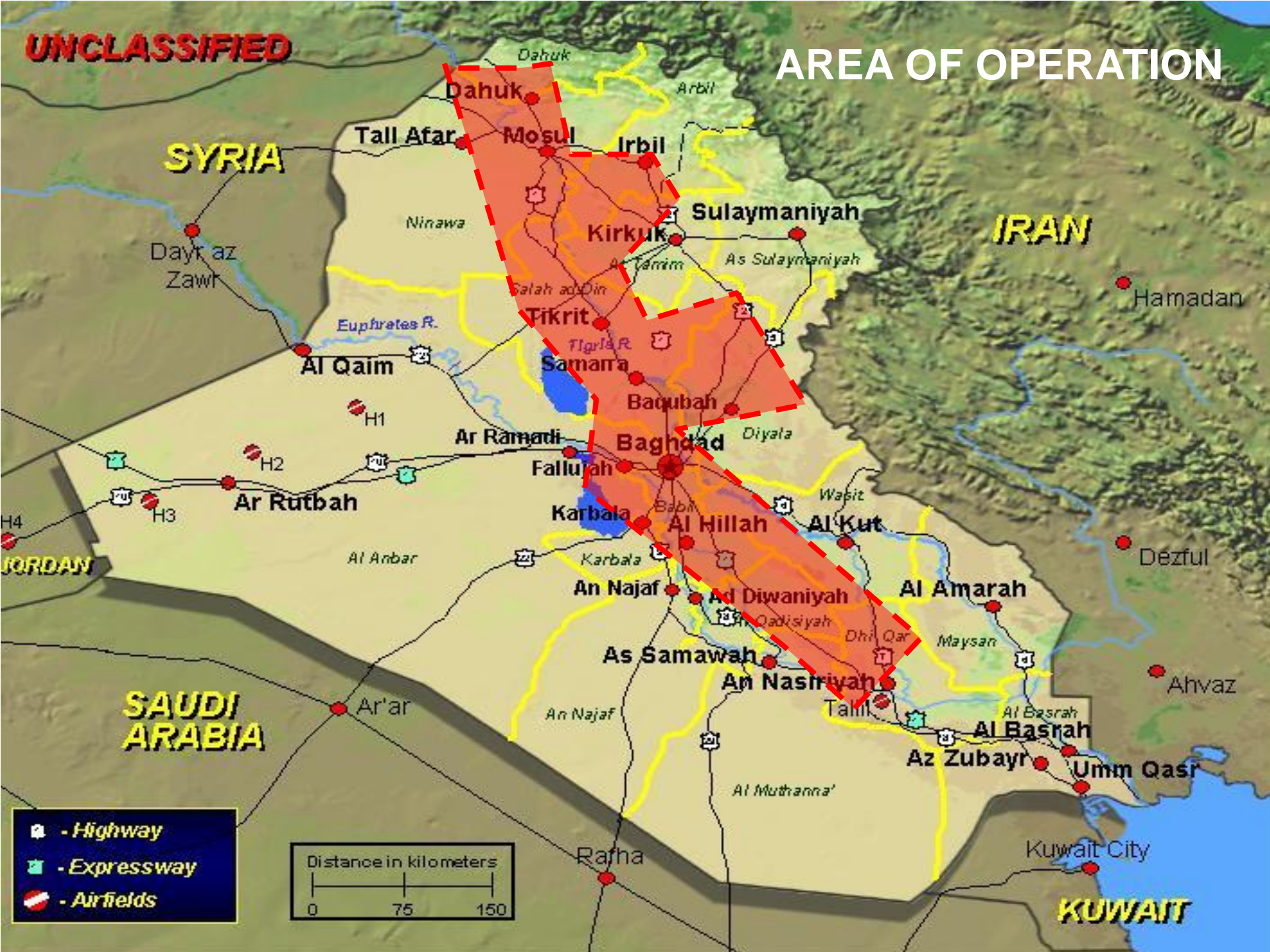



Convoy Configuration

Each truck represents 10 KBR/TCN vehicles



Trail section consists of Wrecker for recovery, and MRAP for rear security



Flex trucks, with 10 white trucks in between each one.



Scout and Lead trucks



Mobility

- Hard surface road networks
- Off Road Capability Limited
- Turn Radius (MAXPRO+ vs. RG33)
- Speed Kills
 - Rollover Threat





Sustainability

- Recovery Challenges
 - KBR Assistance During Missions
- Spare Tire Mounts
- Armor Removal
- Availability of Class IX
- Training



Lethality

- Stable Firing Platform
- Universal Mount
- Lower Silhouette
- Hellfire Lights and Force Protection





Survivability

- Our Experience “MRAPs Save Soldier’s Lives”
- Plus/EFP Armor preferred over Reactive Armor





Connectivity

- Outstanding Crew Internal Communication
 - Bose Headsets
- Radio Placement
 - Radio Control Monitor
- Blue Force Tracker and Movement Tracking System





Add On Equipment

- Self Protective Adaptive Roller Kit (Sparks Mine Roller)
- CREW Systems
 - CVRJ, DUKES
 - RHINO
- IED Lights





QUESTIONS?

