

Challenges in Hard Target Fuze Design and Critical Technology Development

Chad R. Hettler

**Hard Target Systems
Sandia National Laboratories
Albuquerque, NM 87185-0661
crhettl@sandia.gov
(505) 284-9459**

SAND2010-2983C

Unclassified Unlimited Release

**Presented at the 54th NDIA Fuze Conference,
May 2010, Kansas City, MO**

The Challenge of Hard Target Fuze Design

<http://search.janes.com/janesdata/binder/jalw/images/p0130675.jpg>



harsh
environment

- **Stuff breaks in harsh environments**
- Need reliability in future fuze development
 - Reliability, survivability, performance
- Too many failure modes for fly-fix-fly approach

Our Approach

A big problem needs a systematic approach....

1. Discover immature technologies
 - efficiently and effectively guide our development resources
 - system, subsystem, and component levels
2. Characterize and develop models
 - Target impact environments
 - Performance of fuze subsystems and components in target environments
3. Use models to design for reliable performance
 - impact environment models to determine requirements
 - Performance models as tools to design for reliability through the given target environment

Model Based Design Method

Have requirements and ability to design to meet them

- Understand the target environment
 - Mechanical and Electrical
 - e.g. Fuze subsystem must operate through....
- Understand subsystem and component performance variation through stress and electrical disturbances
 - e.g. Given this stress, the current leakage will vary by....



Sandia National Laboratories, Annual Report 2004-2005

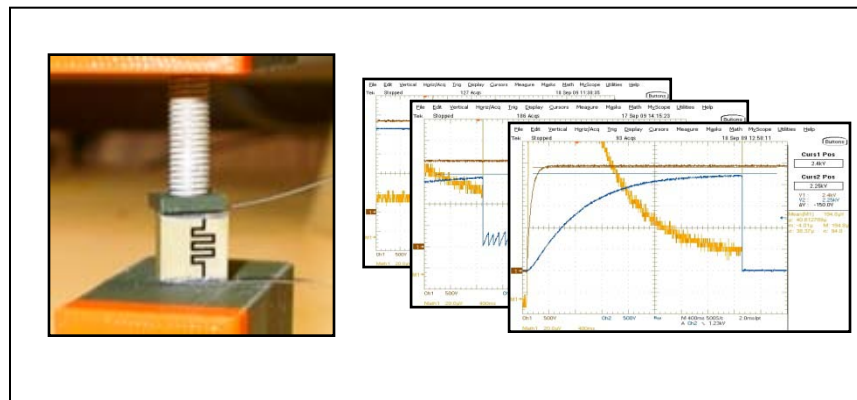

Model Based Design Method

Have requirements and ability to design to meet them



- Use performance models to design fuze electronics with margin for reliable operation through target environments

Too complex for an Edisonian approach

- Can't rely on full-scale tests to uncover all failure modes
- Full scale high-g testing is high dollar
- Development dollars are limited
 - If we're not learning, we're wasting resources



- Need to know what are we learning from our failures
 - If it didn't work....how do we fix it?
 - Finding 10,000 ways it doesn't work....doesn't work for us



“If I find 10,000 ways something won't work, I haven't failed... because every wrong attempt discarded is another step forward.”

- Thomas Alva Edison, US inventor (1847 - 1931), Encyclopedia Britannica

Systematic approach to development

- Assess capabilities to focus development
 - First step is to assess maturity of available technologies
 - At system, subsystem, component levels
 - Can't develop a reliable system without reliable components

Capabilities Assessment

- **Determine Gaps in Technologies**

- System, subsystem, component levels
- Multi-physics; Mechanical, Electrical, Explosive....
- Help roadmap our long term goals and challenges
- Efficiently and effectively guide our development resources

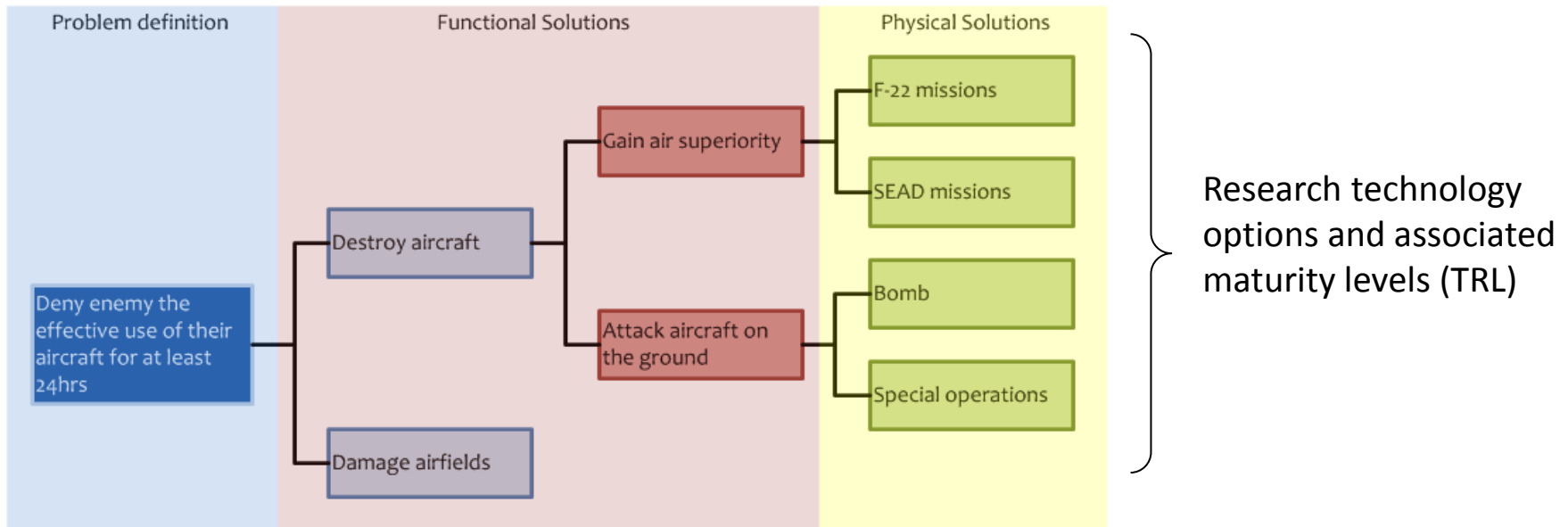

Define immature technologies.... before it's too late

- Fuzes have one good outcome: Initiation when intended
- They have two glaring incorrect outcomes
 - Initiation before or after intended
 - Failure to initiate
- Perform failure analysis before failing expensive tests

If we don't understand failure modes....this is heavy risk



Focus Tests on Understanding Performance

Go / No-Go testing gives limited information

- If we simply increase g-levels until something breaks....
...did we learn how to make it work the next time?



Engineer tests to understand performance success

- If it did work....do we know why?
 - Want enough understanding for reliable transition to other programs, applications, form factors, industry

Need Capabilities to Understand:

- **What is the target environment?**

- Mechanical and Electrical
- Requirement for weapon performance



Sandia National Laboratories, Annual Report 2004-2005

- **How does the fuze perform?**

- Characterize subsystems and components to develop models for performance variations and failure modes in the target environment

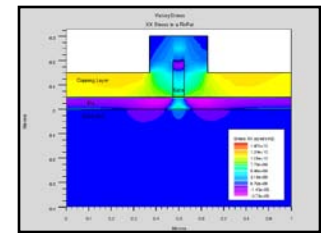

http://www.silvaco.com/tech_lib_TCAD/simulationstandard/2009/oct_nov_dec/a1/a1.html

- **What can we do to prevent failures?**

- Have tools in place to define requirements and design to satisfy them
- Need systematic approach to development

What is the target environment?

- May survive in sub-scale, then fail in full scale
- Fundamental failure modes associated with full-scale environments are not understood
 - Uncharacterized target environments
 - Uncharacterized system performance



<http://search.janes.com/janesdata/binder/jalw/images/p0130675.jpg>



http://search.janes.com/Search/imageDocView.do?docId=/content1/janesdata/captions/jdw/history/jdw2002/jdw05090_2.htm@captions&keyword=penetrator%20target&backPath=http://search.janes.com/Search&P rod_Name=JDW&



Sandia National Laboratories, Annual Report 2004-2005

Characterize Target Environment

- Stresses seen on
 - Weapon body
 - Fuze subsystem
 - Fuze components
- Induced electrical environment
 - Lot of theories....which ones are valid and what are the effects?
 - What types of energies and how are they coupled
 - Plasma from reentry body
 - Charged weapon body
 - System ground loops

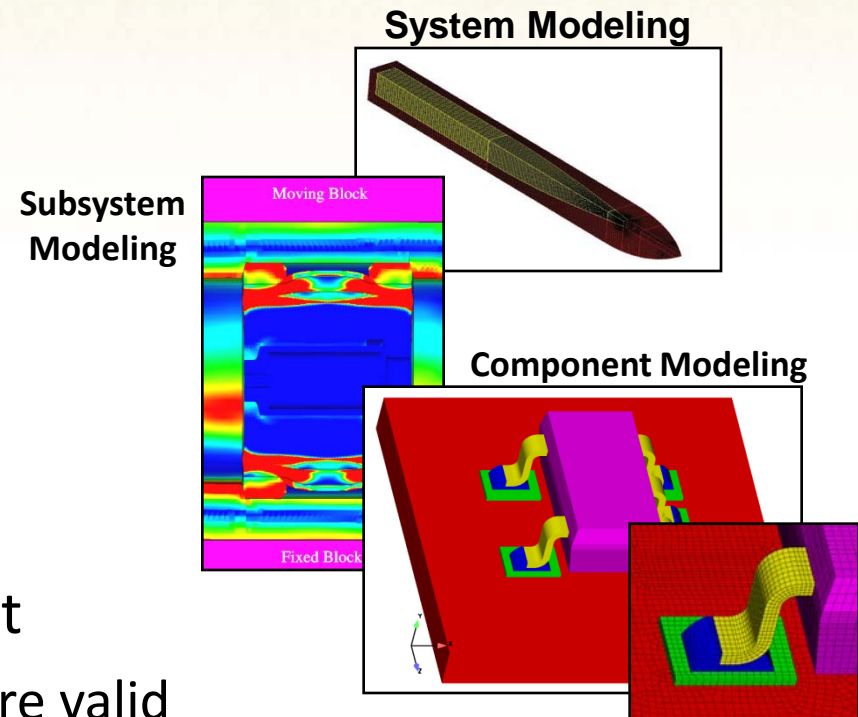

<http://www.dtic.mil/ndia/2009fuze/2009fuze.html>

Understand our designs

Understand the electrical environment

- If we don't know what it **must** perform through
 -We should at least know what it **can** perform through
 - Design for mitigation and understand our performance margins e.g. How much susceptibility to EMI, capacitive coupling....

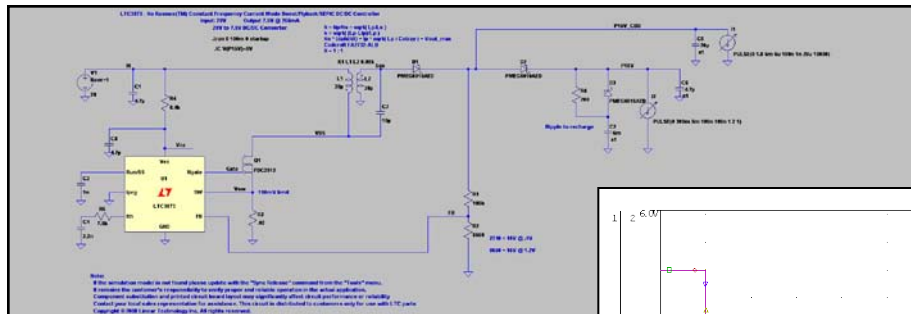

Electrical Parametric
Performance Modeling

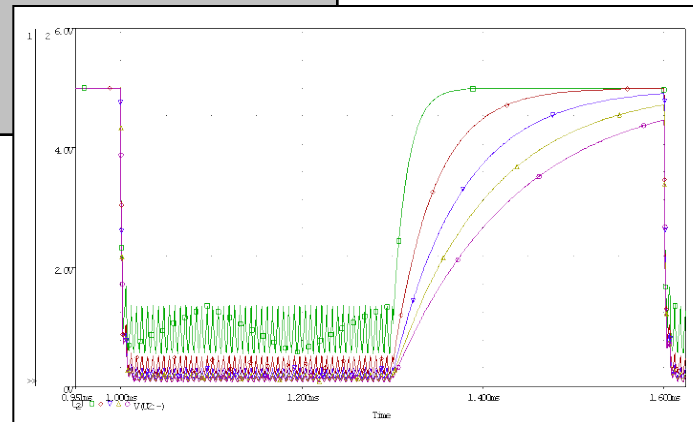

How does the fuze perform?

Knowing the target environment is only useful if we can do something about it

- We need performance models to design for reliability
- What causes failure
 -mechanical damage or electrical performance?



Physical Failure

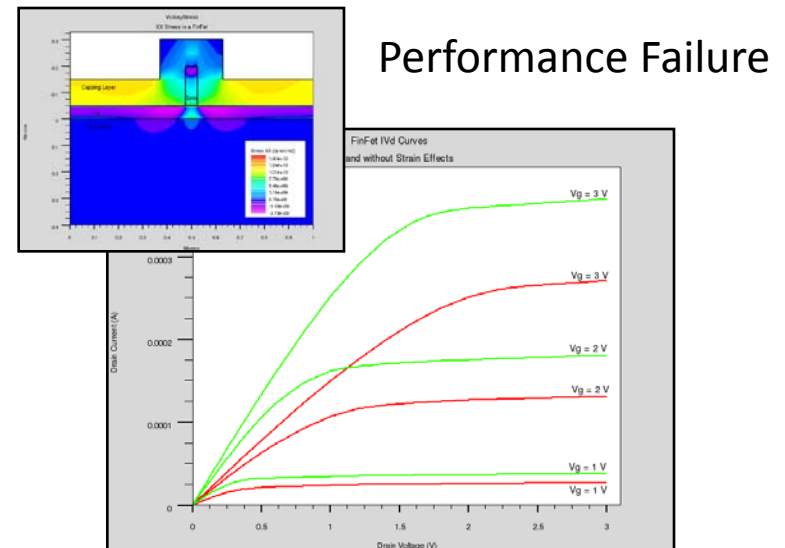

[http://www.silvaco.com/tech_lib_TCAD/simulati
onstandard/2009/oct_nov_dec/a1/a1.html](http://www.silvaco.com/tech_lib_TCAD/simulati
onstandard/2009/oct_nov_dec/a1/a1.html)

Mechanical Failure

- Model the breaking point of hard target components
 - Where does the part physically fail....?

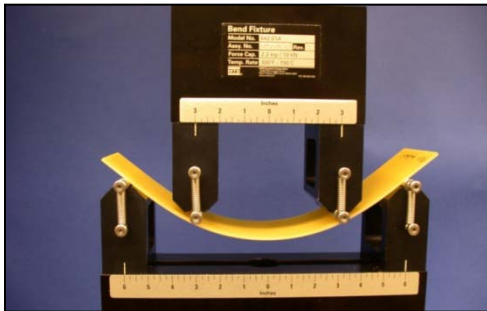

4-point bend test

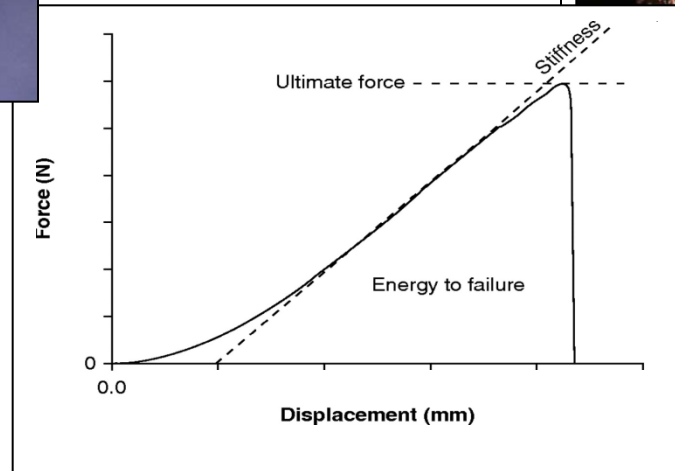

<http://ajs.sagepub.com/content/34/7/1094/F3.large.jpg>

Force vs. Displacement



Physical Failure

Electrical Component Performance

If it survives mechanical impact...will it perform electrically?

- e.g. Stress can effect crystalline structures, effecting intrinsic properties of semiconductors and dielectrics
 - band-gap energy, dielectric constants , current-voltage relationships

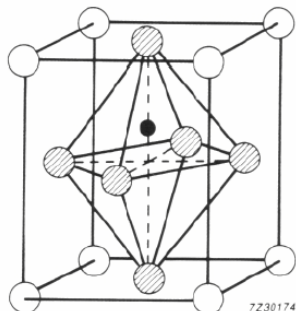
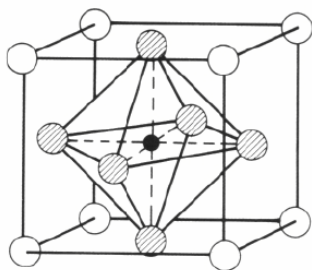

Lattice Deformation

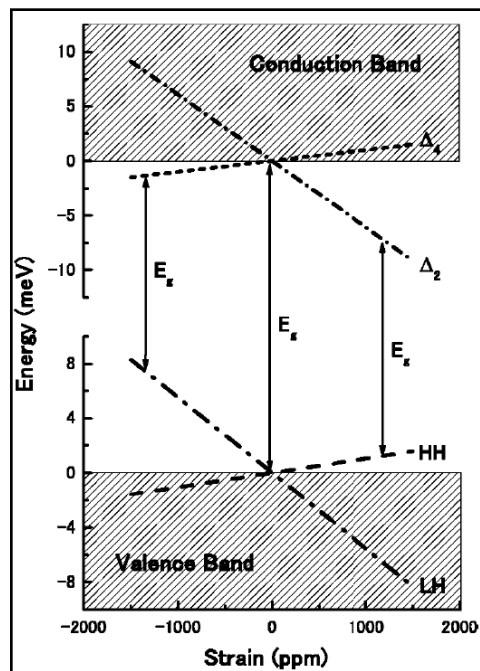

K. Matsuda, Y Kanda, Stress-induced effects on depletion-layer capacitance of metal-oxide-semiconductor capacitors, Applied Physics Letters, vol. 83, n 12, Nov. 24 2003.

E_g vs Strain

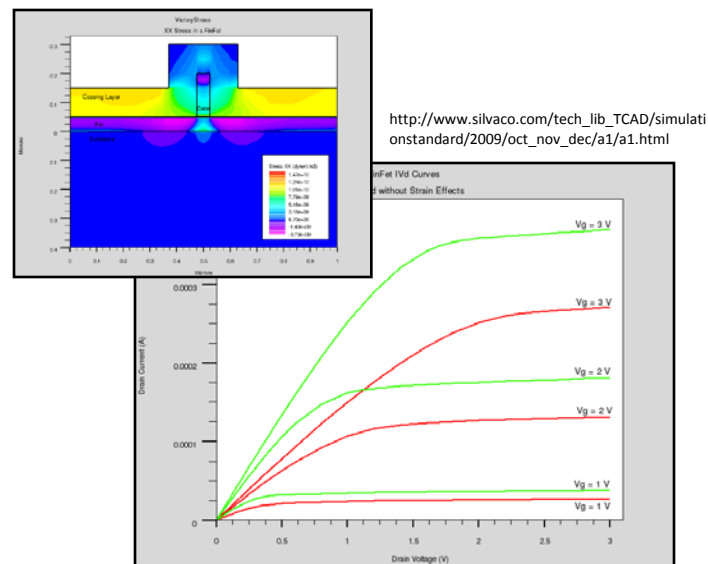

Drain Current vs. Strain

Electrical System Performance

- **At the fuze subsystem level**

- Piezoelectric effects
- EMI
- Voltage level shifts
- Ground bounce

- **At the weapon system level**

- Coupled Energy
- Ground loops

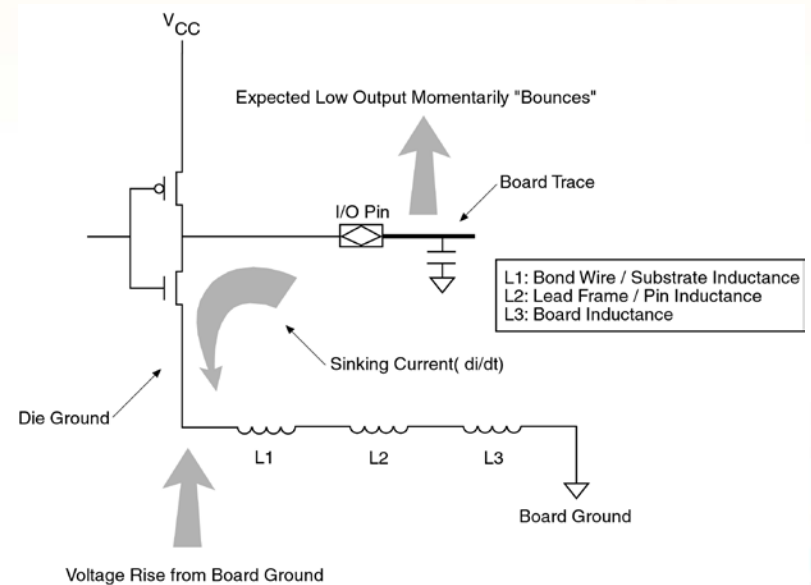

Altera Corporation, Minimizing Ground Bounce & V_{CC} Sag,
www.altera.com/literature/wp/wp_grndbnce.pdf

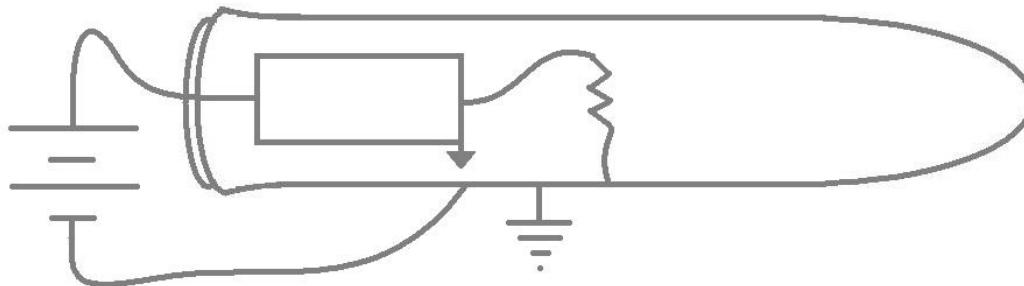

What can we do to prevent failures?

- Stuff breaks in hard target environments
- Big problem needs a systematic approach
 - At system, subsystem, and component levels
 - Identify critical technologies
- Focus resources to efficiently and effectively develop our gaps and immature technologies
- Model based engineering to design for reliable performance

Sandia National Laboratories, Annual Report 2004-2005

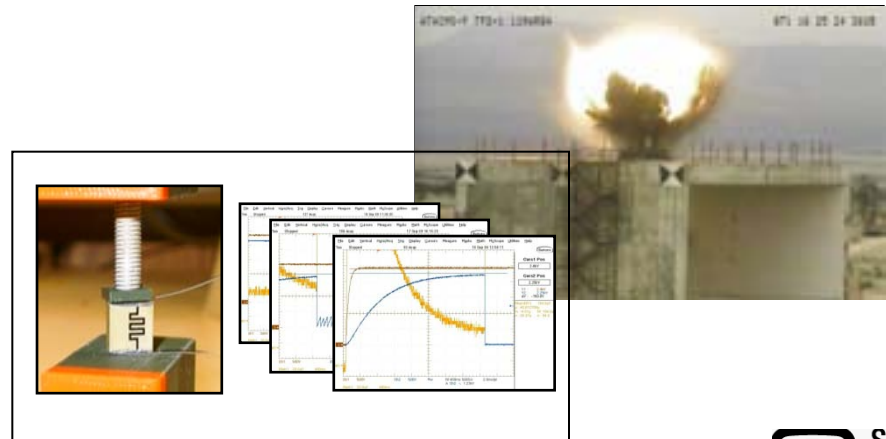

Collaborations



- The Defense Threat Reduction Agency funds work to investigate the effects of stress on the electrical performance of components



- Air Force Research Labs is aiding in this effort



- Army RDECOM is modeling the mechanical effects of stress

Questions / Comments ?



BACKUP SLIDES

What does it all Mean?

- **By failing to address the high-g fuzing problem holistically, the cost is high:**
 - **Poor collaboration**
 - **Duplicated effort**
 - **Poor understanding of high-g science**
 - **Poor integration of test results and analysis**
 - **Unclear understanding of the truly necessary areas of research (focus is lost)**
 - **No/little documented design guidelines for high-g**
 - **And no framework for getting there, either**

It is natural for a problem too big for one group to get to this state. However, when it is realized that the techniques/tools exist to correct the problem, they should be taken advantage of.