



## A-10 Thunderbolt II (Warthog) SYSTEMS ENGINEERING CASE STUDY

David R. Jacques, PhD, LtCol USAF (Ret)  
Dennis D. Strouble, PhD



Air Force Center for Systems Engineering (AFIT/SY)  
Air Force Institute of Technology  
2950 Hobson Way, Wright-Patterson AFB OH 45433-7765

# Human Systems Integration in Early Acquisition: A Historical Example

(Based on A-10 Systems Engineering  
Case Study)

27 October 2010

Dr. Dave Jacques  
Air Force Institute of Technology  
([david.jacques@afit.edu](mailto:david.jacques@afit.edu))



# Tenets of Acquisition Policy



1. System need shall be clearly established in operational terms, with appropriate limits, and shall be challenged throughout the acquisition process... Wherever feasible, operational needs shall be satisfied through the use of existing military or commercial hardware...
2. Cost parameters shall be established which consider the cost of acquisition and ownership... Practical tradeoffs shall be made between system capability, cost and schedule...
3. Logistic support shall also be considered as a principle design parameter...
4. Programs shall be structured and resources allocated to assure that the demonstration of actual achievement is the pacing function... Schedules and funding profiles shall be structured to accommodate unforeseen problems and permit task accomplishment without unnecessary overlapping or concurrency.
5. Technical uncertainty shall be continually assessed... Models, mock-ups and system hardware will be used to the greatest possible extent to increase confidence level.
6. Test and evaluation shall commence as early as possible. A determination of operational suitability, including logistics support requirements, will be made prior to large scale production commitments...
7. Contract type shall be consistent with all program characteristics, including risk...
8. The source selection decision shall take into account the contractor's capability to develop a necessary defense system on a timely and cost-effective basis...
9. Management information/program control requirements shall provide information which is essential to effective management control... Documentation shall be generated in the minimum amount to satisfy necessary and specific management needs.



# Lessons from Vietnam



- Air Force largely unprepared for Close Air Support (CAS) mission
  - A-1, A-37 had insufficient payload, loiter
  - Incompatible comm with ground units
- Army doctrine evolving towards air mobile tactics
  - Increased reliance on armed helicopters
  - Initiated development of AH-56 Cheyenne
- Johnson-McConnell Agreement
  - AF retained CAS mission, but recognized role of Army helicopters for fire support
  - Army gave up large fixed-wing transports





# Task Definition



## Three Mission Tasks

- Close Support Fire (CSF)
  - Armed Escort (AE)
  - Armed Reconnaissance (AR)
- 
- CSF and AE were considered complementary
  - AR involved different weapons and target acquisition systems, considered a secondary A-X mission due to parallel development of AC-130 gunship



# Mission Characteristics (Now called attributes)



Only four key mission characteristics specified !

- **Responsiveness** considered not just speed, but basing locations, availability, loiter time over target, and ability to communicate with ground elements
- **Simplicity** emphasized ease of production, maintenance, and low cost
- **Survivability** concerns would drive redundancy, component placement, protection systems, maneuverability, targeting systems, et.al.
- **Lethality** made it clear that it was not an aircraft development effort, it was a weapon system development
- Mission characteristics drove performance parameters, which resulted in concept aircraft configurations
  - Alternatives evaluated against mission and cost effectiveness measures

Note: All four key mission characteristics for the A-X directly impacted HSI considerations



# A-X Concepts



## Requirements from Dec 1966 Requirements Action Directive

Performance Parameter	Desired	Required
Gross Weight (lbs)	22,500	30,000
Payload - Mixed Ordnance (lbs)	8,000	6,000
Combat Radius (nautical miles)	---	200
Loiter Time @ Combat Radius (hrs)	---	2
Min Maneuvering Speed @ 5000 ft (knots)	120	150
Turn Radius @ Combat Weight (ft)	1,000	2,000
Max Speed @ Sea Level w/ Ext. Ordnance (knots)	550	450

- Concept design studies conducted in 1967
  - Resulted in two government configurations, and four contractor configurations
- Concept determined to be feasible within existing technology
  - Most configurations used turbo-prop designs
  - Identified risk elements included gun/ammunition development and integration, and early IOC
  - Lean avionics packages defined to keep costs down
- Concept Formulation Package completed in 1968



# A-X Concepts



(U) GRUMMAN  
RECOMMENDED DESIGN GENERAL ARRANGEMENT

(Figure UNCLASSIFIED)

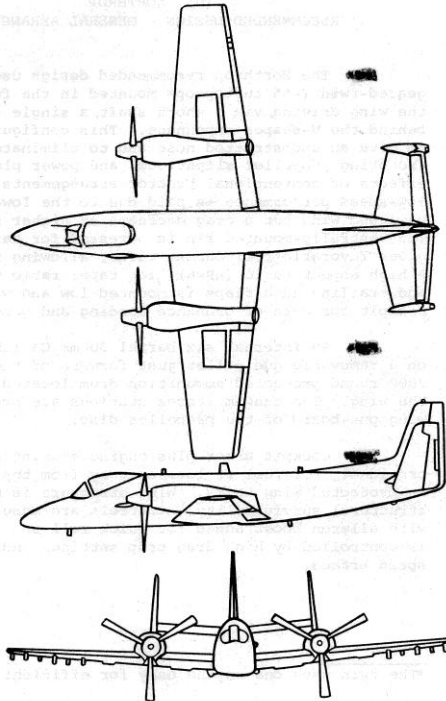

(U) GENERAL DYNAMICS  
RECOMMENDED DESIGN GENERAL ARRANGEMENT

(Figure UNCLASSIFIED)

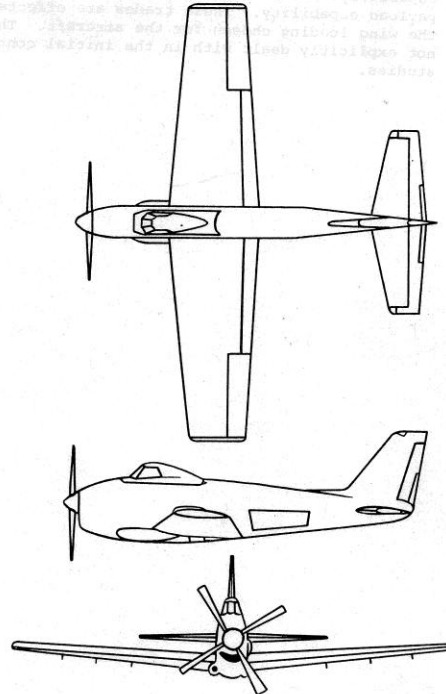

(U) McDONNELL DOUGLAS  
RECOMMENDED DESIGN GENERAL ARRANGEMENT

(Figure UNCLASSIFIED)

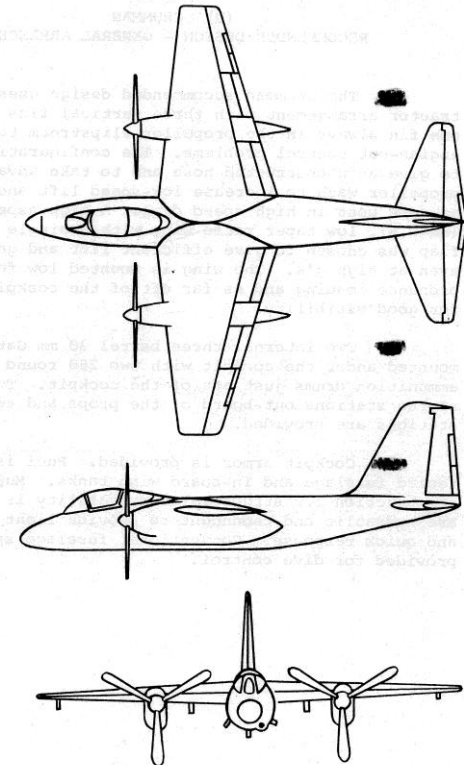

**Notes: Significant design changes occurred during Concept Definition (now referred to as Materiel Solutions Analysis)**

- Single or twin turboprop propulsion gave way to twin turbofan (leveraged Navy S-37 aircraft development)
- Payload essentially doubled to 16,000 lbs – led to aircraft size/cost growth



# Key Mission Characteristics



- ***Responsiveness*** considered not just speed, but basing locations, availability, loiter time over target, and ability to communicate with ground elements
- ***Simplicity*** emphasized ease of production, maintenance, and low cost
- ***Survivability*** concerns would drive redundancy, component placement, protection systems, maneuverability, targeting systems, et.al.
- ***Lethality*** made it clear that it was not an aircraft development effort, it was a weapon system development





# Responsiveness The System of Systems Perspective

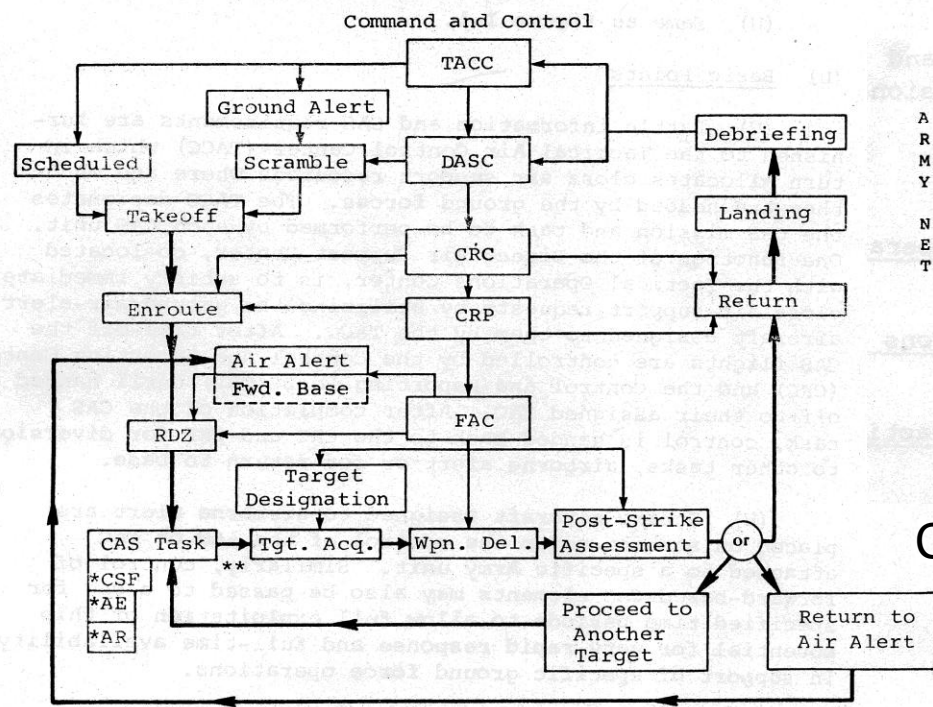

\*AR—armed reconnaissance; AE—armed escort; CSF—close support fires  
 \*\*This sequence occurs every time with CSF and to varying degrees with AR and AE.

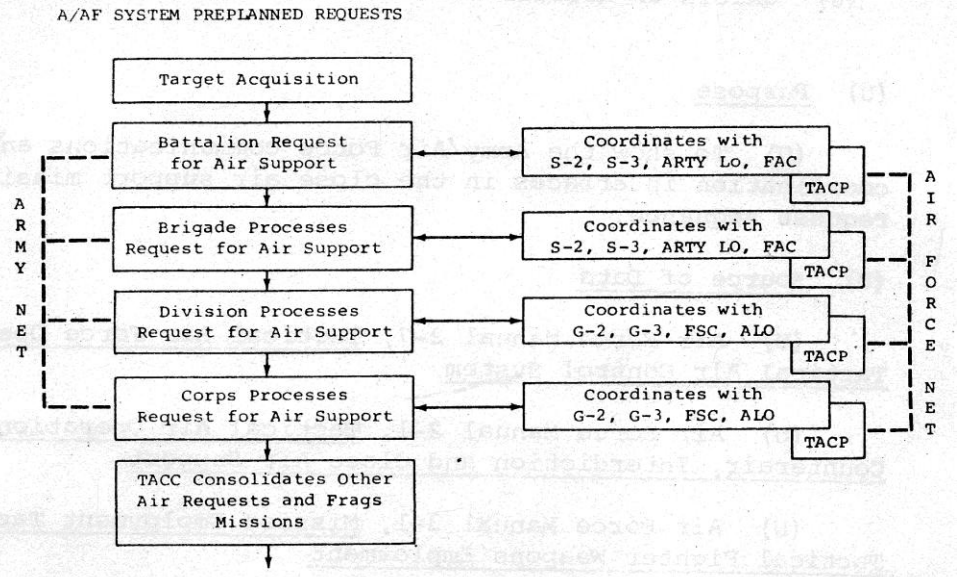

Coordination for Pre-Planned CAS Requests

The Tactical Air Control System (circa 1968)

They defined human-human interface at the SoS/mission level



# Responsiveness

## The Importance of Basing



### Combat Radius and Loiter Time Considerations

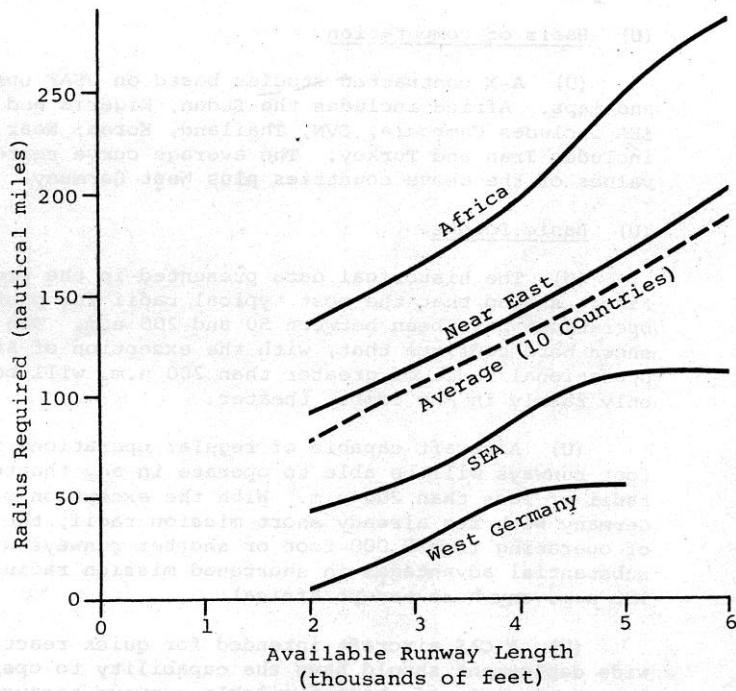

Radius Req'd for 90-Percent Geo-Area Coverage from Available Runways

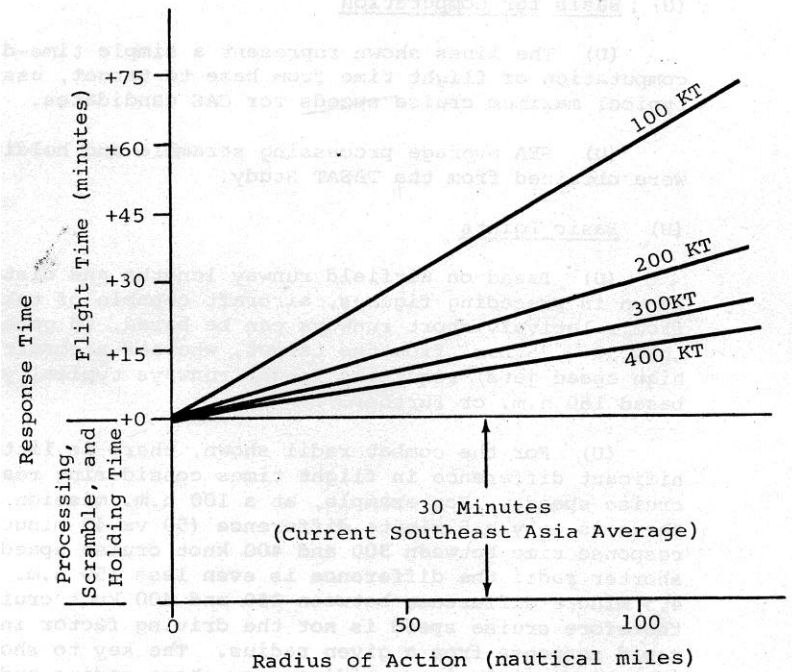

Response Time Versus Mission Radii and Cruise Speed



# Key Mission Characteristics



- *Responsiveness* considered not just speed, but basing locations, availability, loiter time over target, and ability to communicate with ground elements
- ***Simplicity*** emphasized ease of production, maintenance, and low cost
- *Survivability* concerns would drive redundancy, component placement, protection systems, maneuverability, targeting systems, et.al.
- *Lethality* made it clear that it was not an aircraft development effort, it was a weapon system development



# Simplicity ... (... or is it more than that ?)



	AFM 26-3 PLANNING MMH/FH	ACTUAL SEA MMH/FH AVERAGE
F-4	30	33.2
*F-105	40	27.6
F-100	25	26.6
F-5	17	15.5
A-1	10	14.3
A-37	7	7.8

## Maintenance Man Hours/Flight Hour for Vietnam era Aircraft

A. CONSTANT PAYLOAD  
3 Aircraft On Station

B. CONSTANT FORCE  
3,000 Pounds Per Aircraft  
(One 72-UE Wing)

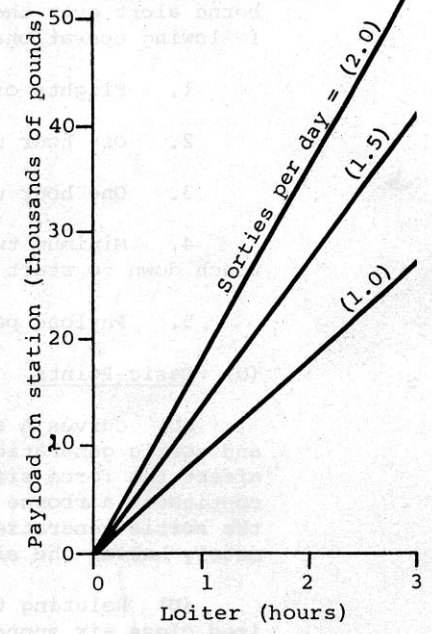
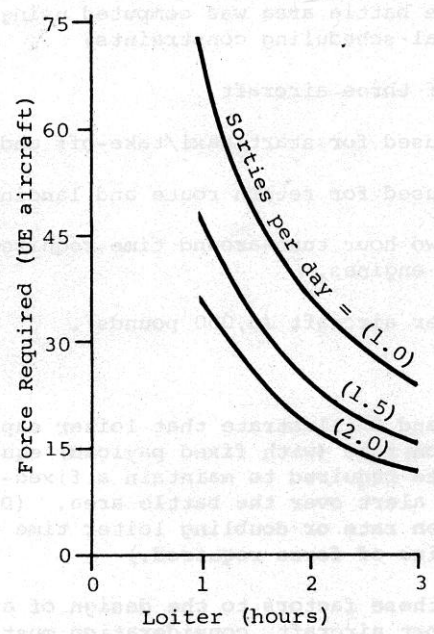

Impact of Loiter Time and Sortie Rate on Force Requirements

NOTES:

- x— Empirical test results
- o- SOURCE model results

MMM/FH are theater averages and include organizational and field level maintenance

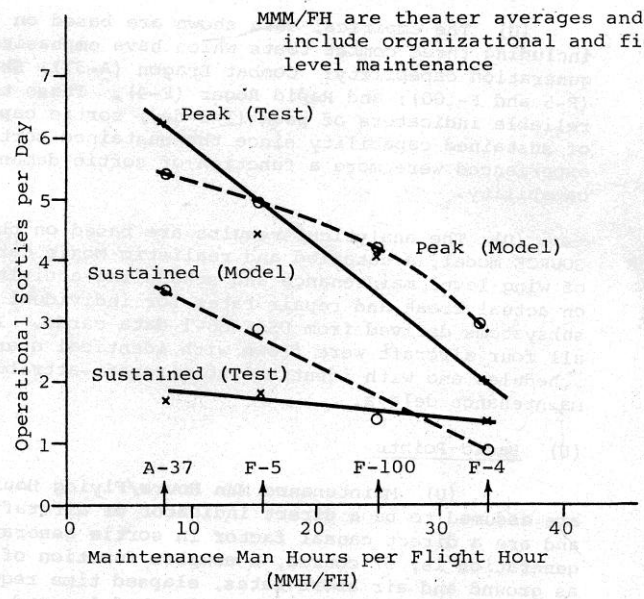



# A-10 Maintenance Features



- Design simplicity, ease of access
  - e.g., designed for 30 minute engine replacement
- Low wing, high engine placement
  - Allowed for engine-on, quick turn re-arming
- Interchangeable left/right side components
  - Engines, landing gear, vertical stabilizers
- Non-load bearing wing panels
  - Damaged skin replaceable in the field
- Designed to be operable and serviceable from forward air bases
  - Including those with damaged runways



# Simplicity

## How much avionics?



### A-X AVIONICS EQUIPMENT

"SKELETON" Below Minimum	"Lean" Minimum	"Lean" Plus 1st Add-On	"Lean" Plus 2d Add-On	"Lean" Plus 3d Add-On
VHF/FM (With Homer)	Doppler Navigator	Radar Added Functions	MTI to Radar	Maverick
UHF/AM (ADF)	Radar Ranger	Terrain Avoidance	Inertial Nav.	
IFF (A-G)	VHF/FM (With Homer)	(Manual)	Night Sight	
Voice Scrambler	UHF/AM (ADF)	PPI Map	(Optical)	
Intercom	IFF (A-G)	Beacon Interrogation		
TACAN	Voice Scrambler			
UHF/ADF	Intercom			
Radio Altimeter	TACAN			
ILS	UHF/ADF			
Air Data Converter (Computer)	Radio Altimeter			
Attitude, Heading, Reference	ILS			
S-Band Radar Beacon	Air Data Converter (computer)			
Continuous-Solution Stabilized Sight	Attitude, Heading, Reference			
(Depressable Optical Sight)	Continuous-Solution Stabilized			
Gun Camera (2) Maurer 220	Sight (Depressable Optical Sight)			
Integrated Armament Control System	Gun Camera (2) Maurer 220			
	Integrated Armament Control System			
<b>COSTS</b>	\$127,780	\$34,000	\$10,000	\$20,000
Accumulative Costs		161,780	171,780	191,780
Weight (Pounds)	367	83	20	35
Accumulative Weight	367	450	470	505
				545



# Weather Suitability



Percent of time minimums better than—

	2,000 ft./3 miles	1,000 ft./1 mile
--	-------------------	------------------

82%	SEA	95%
62%	Europe	86%
78%	Korea	88%
81%	(5 Theater Average)	94%

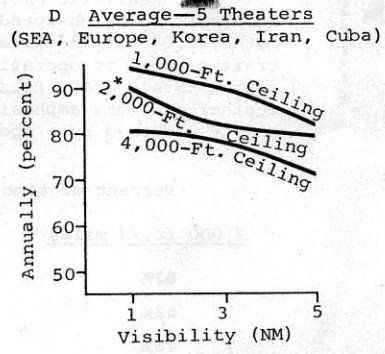
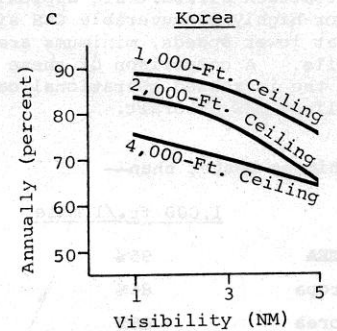
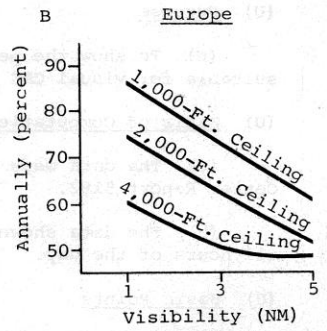
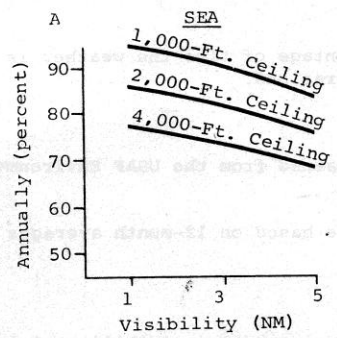

**Assumptions**  
 1. Ceiling: 5/10 or greater cloud cover  
 2. Annual: all hours

**Assumptions**  
 1. Time from point of alignment to pullout = 10 seconds  
 2. Pullout at ground level

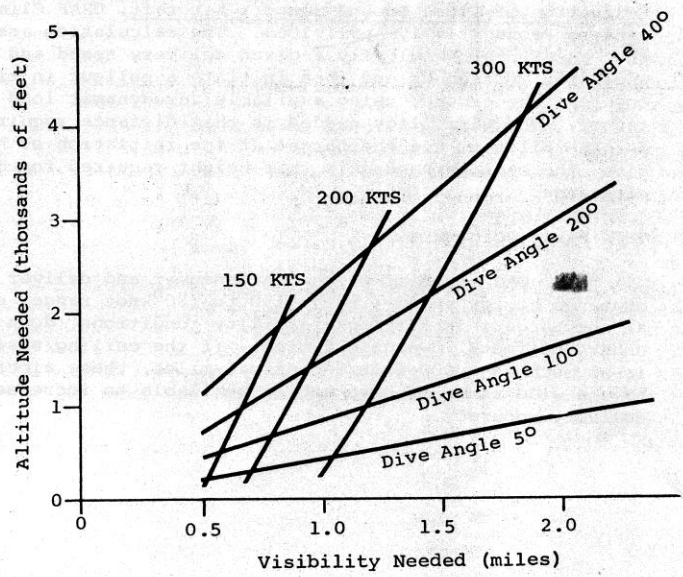

## Availability of Weather Suitable for CAS Operations

Attack Profile Nomogram



# Do you recognize this A/C?



## A-10B

- Night/Adverse Weather
- Two seat (tandem)

- A-10A was simple enough to operate with a lone pilot
- Did good HSI from the operator perspective make a two seat variant unnecessary?







# Impact of Avionics Decisions

## A-10 Night Operations



- Night operations in Desert Storm
  - Pilots used IR Maverick seeker as night vision aid
- Success and survivability in night operations serve as a testament to other design features and skilled, innovative pilots
- Badly needed avionics upgrades came well after Desert Storm



# Key Mission Characteristics



- *Responsiveness* considered not just speed, but basing locations, availability, loiter time over target, and ability to communicate with ground elements
- *Simplicity* emphasized ease of production, maintenance, and low cost
- ***Survivability*** concerns would drive redundancy, component placement, protection systems, maneuverability, targeting systems, et.al.
- *Lethality* made it clear that it was not an aircraft development effort, it was a weapon system development



# Survivability

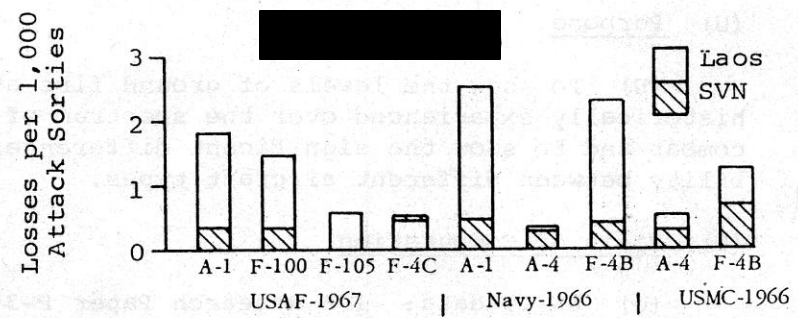
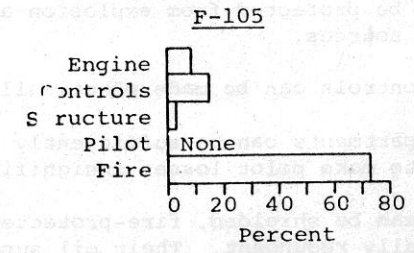
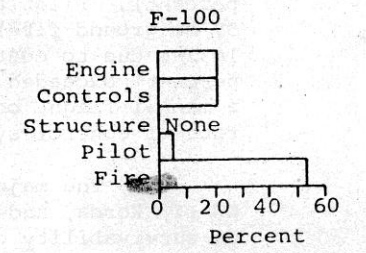
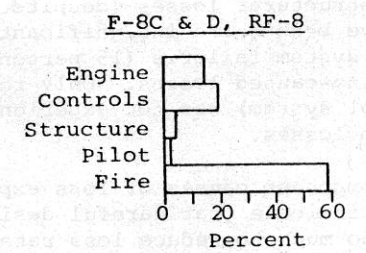
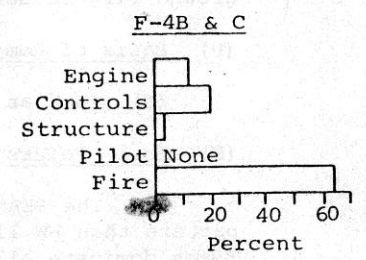
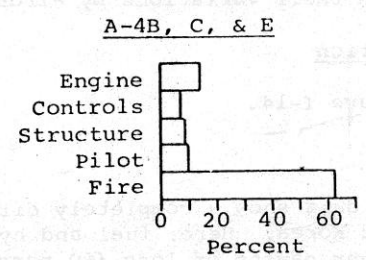
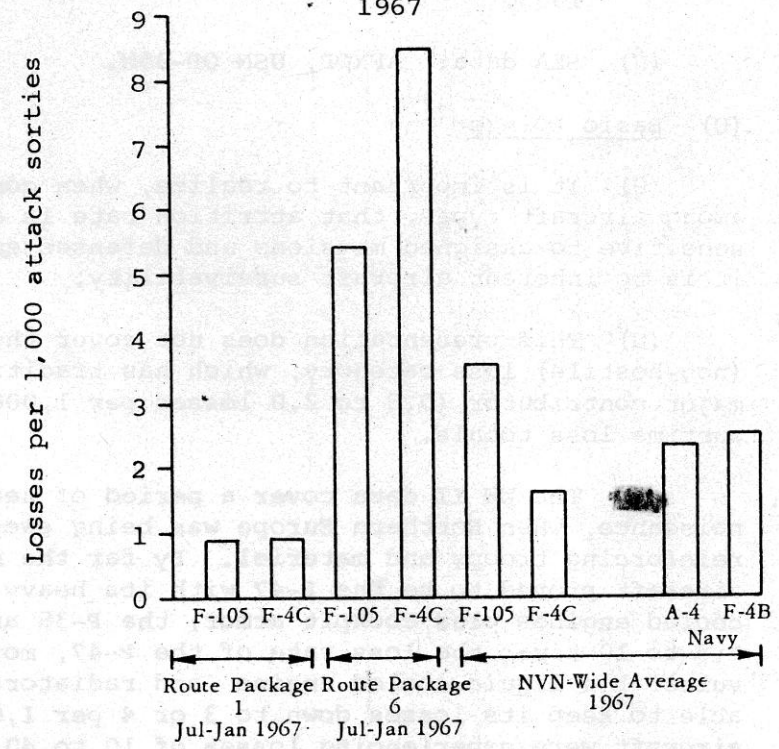

FIGURE I-13C

(U) GROUND FIRE ATTRITION, NORTH VIETNAM 1967



(Known Causes Only)

## Cause of Aircraft Ground Fire Loss in Southeast Asia

## Ground Fire Attrition in South Vietnam and Laos



# Survivability

## How to avoid being hit in the first place

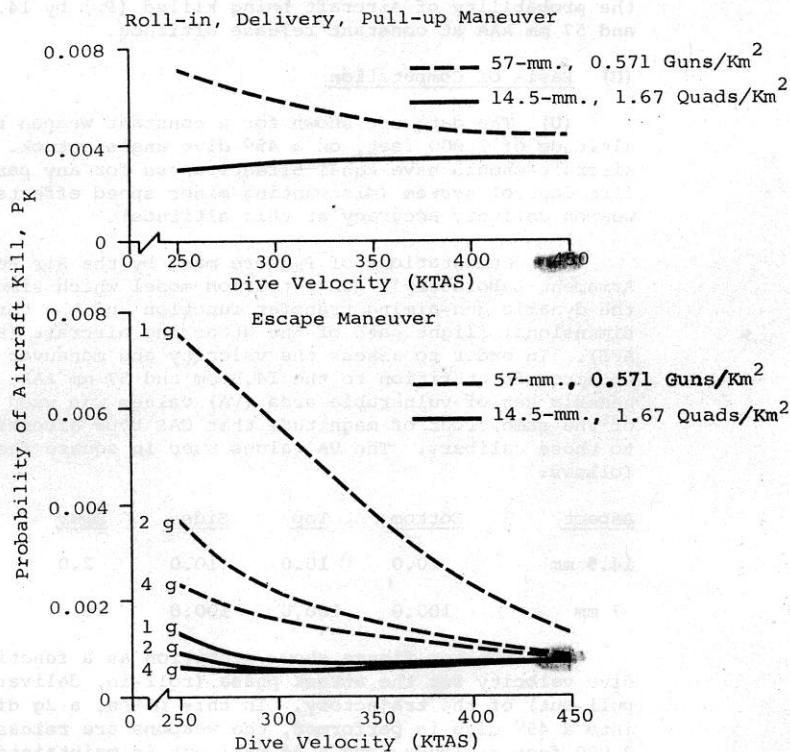

Relative Aircraft Attrition Versus Velocity and Maneuver

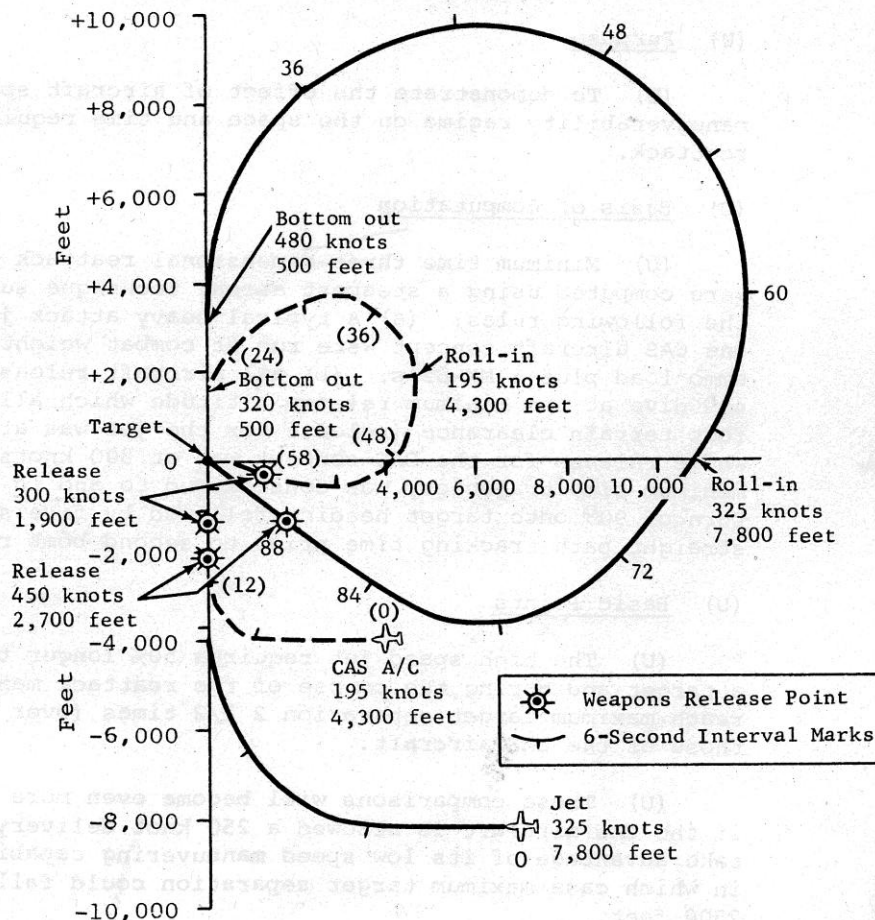

Time and Space Required for Re-Attack Minimum time Trajectory



# Survivability Features



- Titanium “bathtub”
- Redundant wing spars
- Twin tail, oversized ailerons
- Redundant flight control with manual backup
- Two engines, widely separated
  - Placement provides partial shielding of IR signature
  - Protection from FOD, AAA fire
- Self-sealing fuel tanks, protected by fire-retardant foam
- Rugged landing gear design
  - Hinged toward rear – deployable without hydraulic power
  - Semi-protruding – accommodates gear-up belly landings



# Demonstrated Survivability



- Capt Kim Campbell's aircraft takes hit(s)
- Loss of hydraulics for control
- Manual backup allows aircraft (and pilot!) to come home





# Demonstrated Survivability



## One of the Six A-10s Lost in Desert Storm.

“Wheels up, hard stick landing. Everyone said it couldn't be done, including the Flight Manual's and Tech Orders... pilot Capt Rich Biley proved'm wrong on 22 Feb 1991! ... Capt Biley was unhurt during the crash.” \*



## Repaired Aircraft 80-186

This Aircraft was damaged on three separate occasions during Desert Storm, the last one resulting in over 300 holes. The plane was repaired and continued to fly and fight.



# Key Mission Characteristics



- *Responsiveness* considered not just speed, but basing locations, availability, loiter time over target, and ability to communicate with ground elements
- *Simplicity* emphasized ease of production, maintenance, and low cost
- *Survivability* concerns would drive redundancy, component placement, protection systems, maneuverability, targeting systems, et.al.
- **Lethality** made it clear that it was not an aircraft development effort, it was a weapon system development





# Lethality

Was it sacrificed for other characteristics?



In a word ...

**NO!**



- Aircraft designed around gun, and ability to bring gun to bear on targets
  - The relatively few augmentations to the avionics suite were associated with targeting aids for gun and Maverick



# Good HSI on the A-10?



## Generally, YES!

- HSI clearly evident in key characteristics driving the concept formulation effort
- All aspects of HSI as currently defined were clearly evident in the A-10 development
- Survivability and Maintainability of the system are especially notable

## Shortcomings

- Minimal avionics made it marginally suitable for night operations – a human factors issue
- Depleted uranium shells raise environmental and safety concerns
- Lapses in sustainment throughout 1990's resulted in safety of flight issues
- Others?



# Air Force Center for Systems Engineering Case Studies



**Hubble Space Telescope**

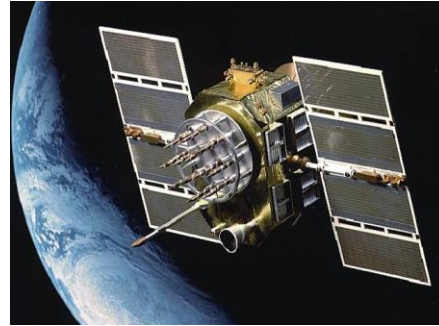

**GPS (Global Positioning System)**



**F-111**



**C-5**

Available as pdf downloads at:  
<http://www.afit.edu/cse/>



**TBMCS (Theater Battle Management Core Systems)**



**A-10**



**KC-135 Simulator**



**Global Hawk**



# Conclusion



- An often quoted statement:
  - Those who don't learn the lessons of the past are condemned to repeat them
- So are we learning them, or repeating them?





# Questions?





# Back-ups/Holding Area





# Competitive Prototyping



- Recall acquisition tenet # 5
  - Technical uncertainty shall be continually assessed... Models, mock-ups and system hardware will be used to the greatest possible extent to increase confidence level.
- The A-X (termed A-10 after downselect) became a pilot program to demonstrate competitive prototyping on a major system development effort\*

\* The publication of DoD 5000 did not occur until a few months after the start of the A-X development program, but these policy ideas from the Office of the Secretary of Defense clearly influenced the A-X program formulation. In some respects, the A-X program was a test bed for considerations such as design-to-cost, supportability in design, and competitive prototyping.



# A-X Prototyping



- A-X Pilot – Parallel Undocumented Development
  - Favored by DepSECDEF David Packard and AFSC/CC Gen Ferguson
  - Require minimal documentation during the competitive prototype phase to encourage innovation and initiative on the part of the contractor.
  - Expected to reduce technical risk and lead to a better source selection decision at the expense of higher RDT&E cost
- A-X was unique in this approach
  - F-X (later termed F-15), initiated in the same year, followed traditional “paper” Concept Definition approach to source selection





# Competitive Prototyping on A-X



- Aircraft
  - Two competitors selected from six bidders for competitive prototyping phase
    - Northrop (YA-9) and Fairchild (YA-10)
    - Competitive fly-off by AF pilots after ~2.5 years in development
    - Downselect based on design, cost, risk, and flying performance
- Gun
  - Two competitors selected to design/build prototype guns
    - GE (GAU-8) and Philco-Ford (GAU-9)
    - Each competitor responsible for separate ammunition development
    - Competitive shoot-off after ~2.5 years in development; only GE was able to demonstrate a satisfactory gun system
- Ammunition
  - After gun downselect, GE directed to retain two ammunition subcontracts
  - Targeted downselect for ammunition was to be two years after IOC for first independent ammunition order; prior orders part of gun contract



# A-X Competitive Prototyping Rationale and Outcomes



- Aircraft development was considered low risk, but gun development and integration was considered higher risk
  - Ammunition for gun was also considered higher risk
  - Ammunition cost was projected to make up 90% of the life cycle cost for the gun system
- Aircraft fly-off successful for both Northrop and Fairchild
  - Fairchild A-10 chosen based on cost, risk, and a “simpler” design for manufacture and maintenance
- Gun prototype demonstration eliminated Philco-Ford from consideration, and positively demonstrated feasibility and effectiveness of GE design
- Reports have suggested that extensive efforts in technology development and competition contributed to an 80% reduction in ammunition from the original cost estimate