



# Ground Transportation and Engineer Systems (GTES) PG-15

## Portfolio Overview & Small Business Opportunities

14 Dec 11



### DOD Standard Generators



### USMC Unique Generators



### Tools / Customer Support

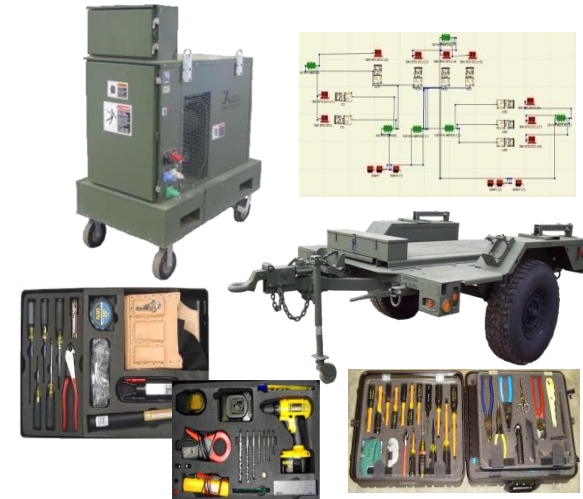

### Integrated Trailer ECU - Generator

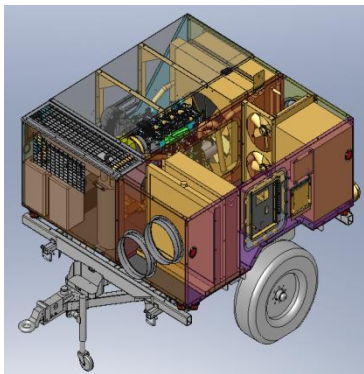

### Power Distribution

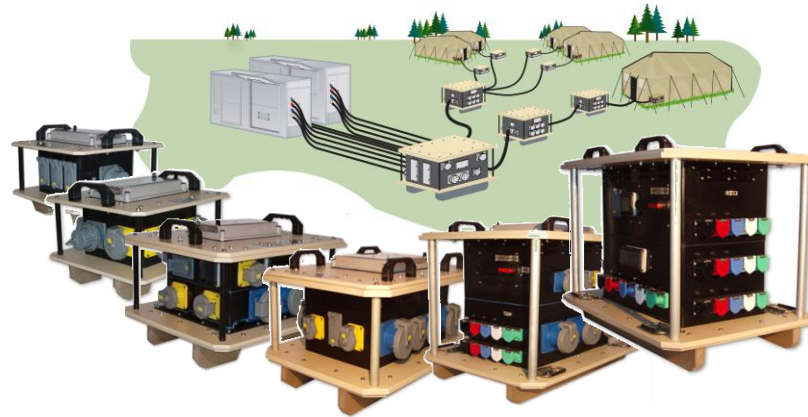

### Floodlight Sets





### Environmental Control Units



### Special Customer ECUs



### Field Refrigeration



### In-Field Ice Making / Water Chilling (food service, mortuary affairs)



### Tools / Customer Support





#### Radio Power Adaptors



#### Power Supplies



#### Renewable Energy



#### On-Board Power

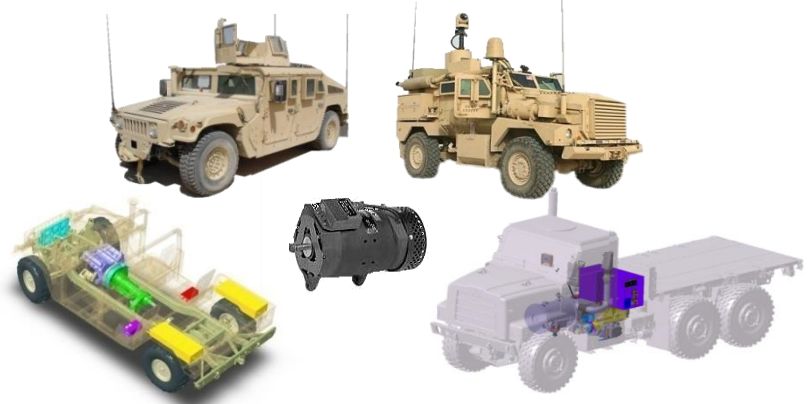

#### Battery Management / Sustainment Systems





**PALCON**



**JOINT MODULAR INTERMODAL CONTAINER (JMIC)**



**QUADCON**



**SMALL FIELD REFRIGERATION SYSTEM  
TRICON**



**LARGE FIELD REFRIGERATION SYSTEM  
20' ISO**



- Improved AN/PRC-117 Radio Power Adaptor

- RFP in 3<sup>rd</sup> QTR FY-12



- Man Portable Renewable Energy System

- RFP in 3<sup>rd</sup> QTR FY-12



- Generator / Trailer Interface Kit manufacturing

- RFP in 4<sup>th</sup> QTR FY-12



- Environmental Control Unit Acoustic Testing

- Request for Quote in 2<sup>nd</sup> QTR FY-12



- Pulse Solar Chargers for Tactical Generators

- GSA or Small business Request for Quote in 4<sup>th</sup> QTR FY-12



- Joint Modular Intermodal Container

- Potential RFP in 1<sup>st</sup> QTR FY-13





### Mine Roller



### Vehicle Mounted Mine Detector



### Route Clearance Blade



### Hand Held Detectors

### ENFIRE



### Interrogation Arm





### Assault Breacher Vehicle



### Mk 154, Mk 155



### Armored Combat Earthmover



### Family of Explosive Ordnance Disposal



### Spider



### Family of Bridging

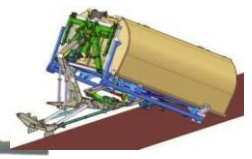



# MARINE CORPS SYSTEMS COMMAND

EQUIPPING THE WARFIGHTER TO WIN

Program Manager  
Engineer Systems





### Family of Engineer and Construction Tool Kits (FECTK)

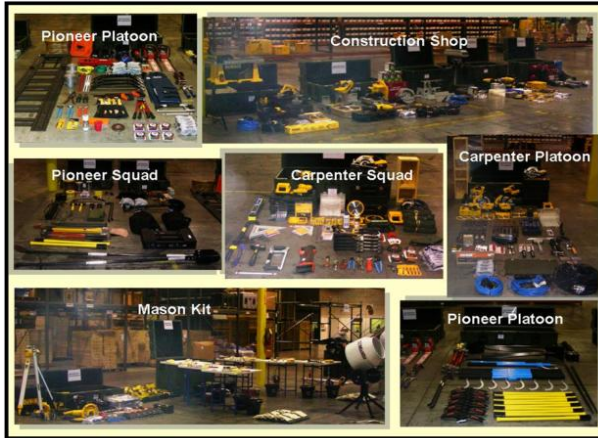

### Water Supply Support Equipment (WSSE)

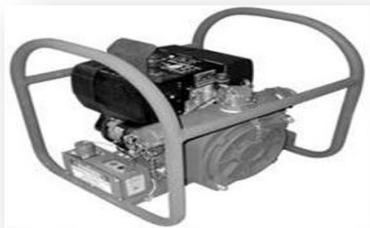

### Tactical Fuel Systems (TFS)





- EOD Technicians Kit
  - RFP in 3<sup>rd</sup> QTR FY-12



- EOD General Purpose Kit
  - RFP in 3<sup>rd</sup> QTR FY-12



- EOD IED Kit
  - RFP in 3<sup>rd</sup> QTR FY-12



- EOD Disposal Kit
  - RFP in 3<sup>rd</sup> QTR FY-12







**PG-15 is looking for opportunities with businesses who exhibit:**

**- Innovation**

- Lighter materials and systems
- More energy efficient
- Paradigm in processes and/or products

**- Affordability**

- Cost
- Quality

**- Business Acumen with government agencies**