

GENERAL DYNAMICS

Land Systems

46th Annual Gun & Missile Systems Conference and Exhibition

**Advances in Multipurpose Warhead Technology:
Hellfire Integrated Blast Fragment Sleeve (HF IBFS) Warhead
for the Hellfire R Missile System**

**Craig Thomas
Mechanical Engineer
General Dynamics-OTS**

11 April 2011

Acknowledgements

Hellfire IBFS Team



LOCKHEED MARTIN



GENERAL DYNAMICS
Ordnance and Tactical Systems

General Dynamics OTS is conducting an accelerated demonstration and qualification program of the Hellfire Integrated Blast Fragmentation Sleeve (HF IBFS) Warhead in support of Lockheed Martin and the US Army Joint Attack Munition Systems Program Executive Office (JAMS PEO)

Hellfire Missile Background

- **Hellfire Missile System**
 - Modular “fire and forget” missile system composed of several target specific warhead variants
 - Deployed from rotary wing aircraft and fixed wing aircraft
 - AH-64 Apache Helicopter Gunship
 - Predator and Reaper Unmanned Aerial Vehicles (UAVs)
 - USMC AH-1W Super Cobra Helicopter
- **Insensitive Munitions (IM)**
 - A munition that will not detonate under any condition other than it’s intended mission
 - Strong focus to reduce chance of accidental explosions in hostile environments (i.e. fire, shock, and bullet or fragment impacts)
 - Munition sensitivity can be reduced by utilizing IM compliant explosives and by implementing IM specific design features

Modern Battlefield Threats

- **Warfighters are faced with a multitude of threats:**

- *Heavy Armor*
- *Reinforced Urban Structures/Bunkers*
- *Light Armor Vehicles/Vessels*
- *Armed Personnel*



Multipurpose Warhead Objective

At present, multiple Hellfire Missile configurations required to defeat full suite of targets

HF IBFS Combines Tandem Shaped Charge Technology with Penetration and Fragmentation Capability in the *HELLFIRE "R"*



HF IBFS Provides the Warfighter with a Single Weapon Solution to Multiple Battlefield Threats

Heavy/Light Armor
Defeat

Structure/Bunker/Personnel
Defeat

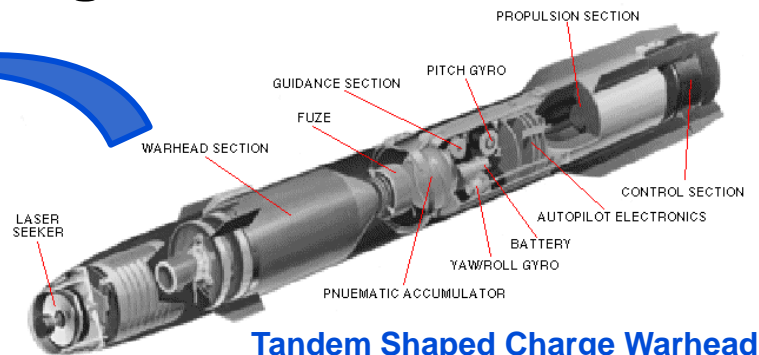

Tandem Shaped Charge Warhead
HELLFIRE "K"



Blast Fragmentation Warhead
HELLFIRE "M/N"

Shaped Charge 101

- Uses shaped explosive to form a stretching “jet” of dense material in order to defeat the armored target

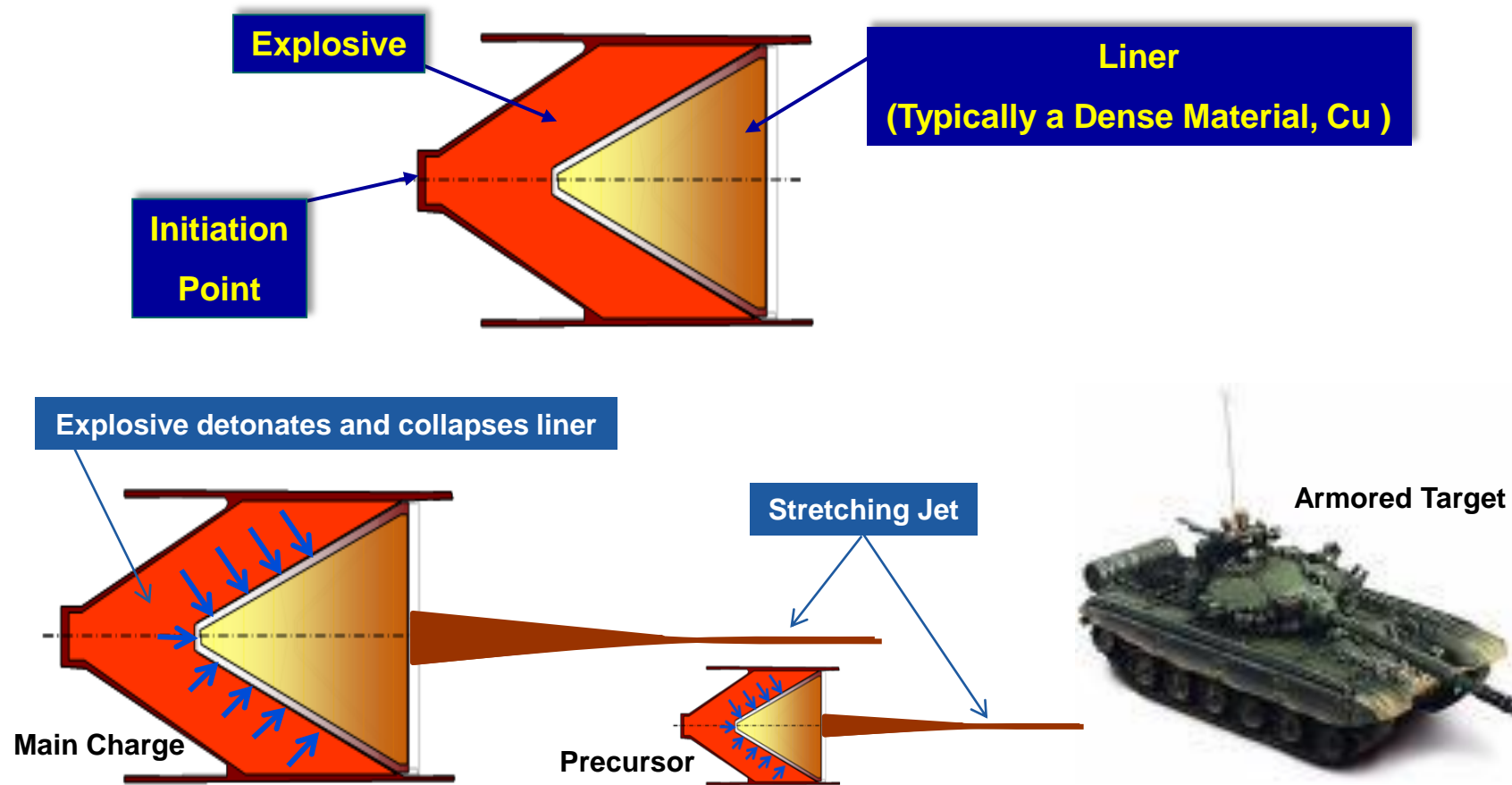

Design Overview

PRIMARY FUNCTIONAL ELEMENT:

HF IBFS Main Charge (MC) Warhead

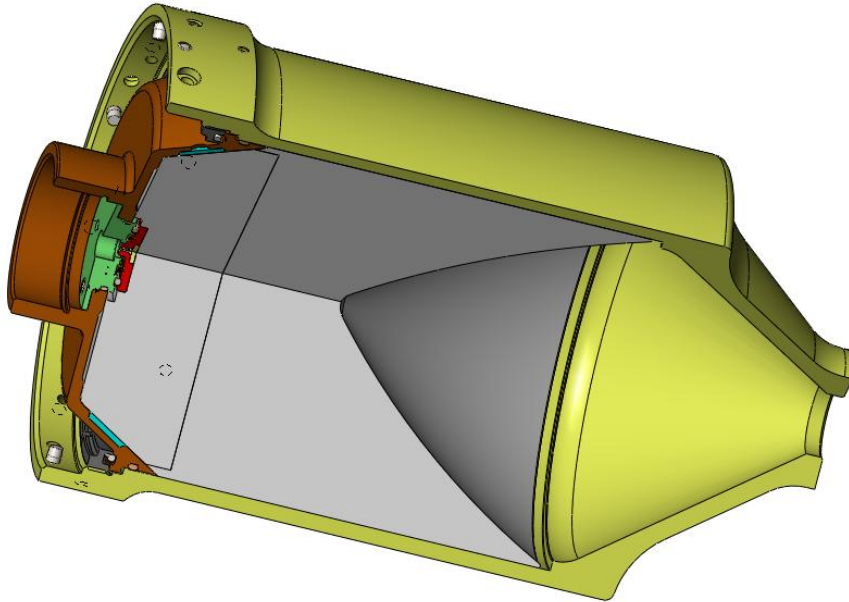

- Advanced Shaped Charge Liner for Heavy Armor Defeat
- Hardened Steel Body for Wall Penetration and Fragmentation Lethality
- Insensitive Munition (IM) Compliant Explosive
- Design Features for Enhanced IM Performance

HF IBFS Precursor (PC) Warhead

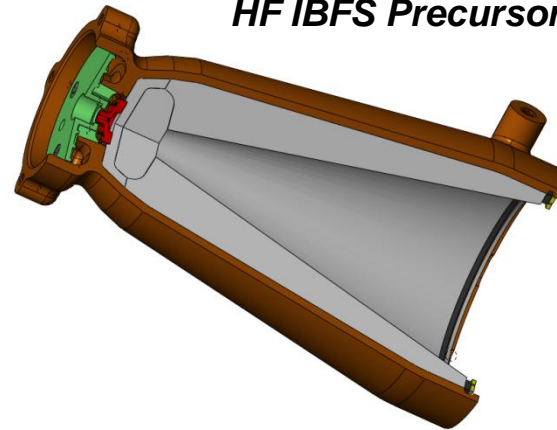

- Engage and Defeat Explosive Reactive Armor (ERA)
- Conical Shaped Charge Liner design
- Insensitive Munition (IM) Compliant Explosive



Accelerated Schedule to Production

- Aggressive Design Verification and Qualification schedule
- Test and Demonstration Phase successfully completed
 - Exceeds performance capability of current Hellfire variants
- Currently in Qualification and Pilot Production Line phase

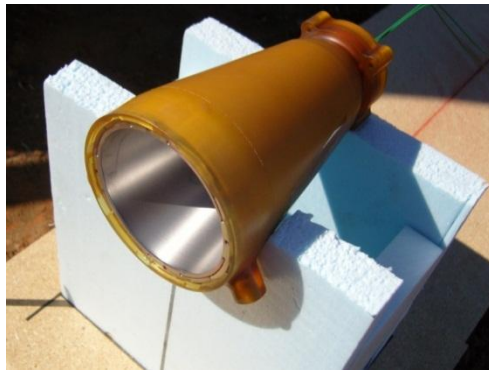

Successful Performance Testing

- **Performance Capabilities Demonstrated:**
 - Exceeds Heavy Armor penetration capability of current Hellfire variants
 - Armor defeat across temperature extremes
 - Penetration of structural targets with detonation upon exit
 - Lethality via high velocity fragmentation
 - Defeat of advanced ERA targets

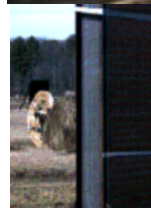

Performance Demonstration:



Performance Demonstration: Structure Defeat



Precursor Jet

Precursor Detonation

Main Charge Detonation
Behind Target

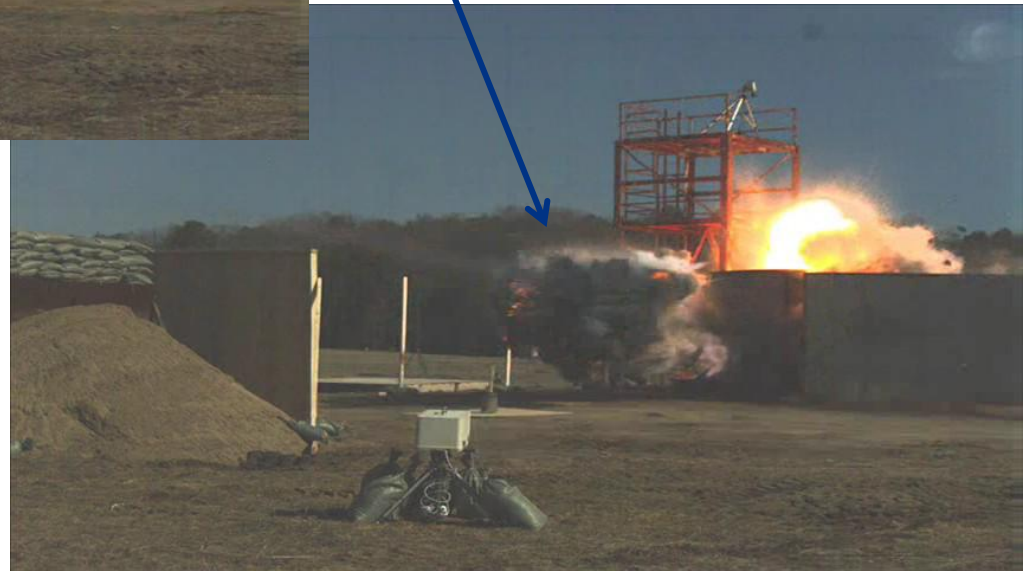

Performance Demonstration: Armor Defeat

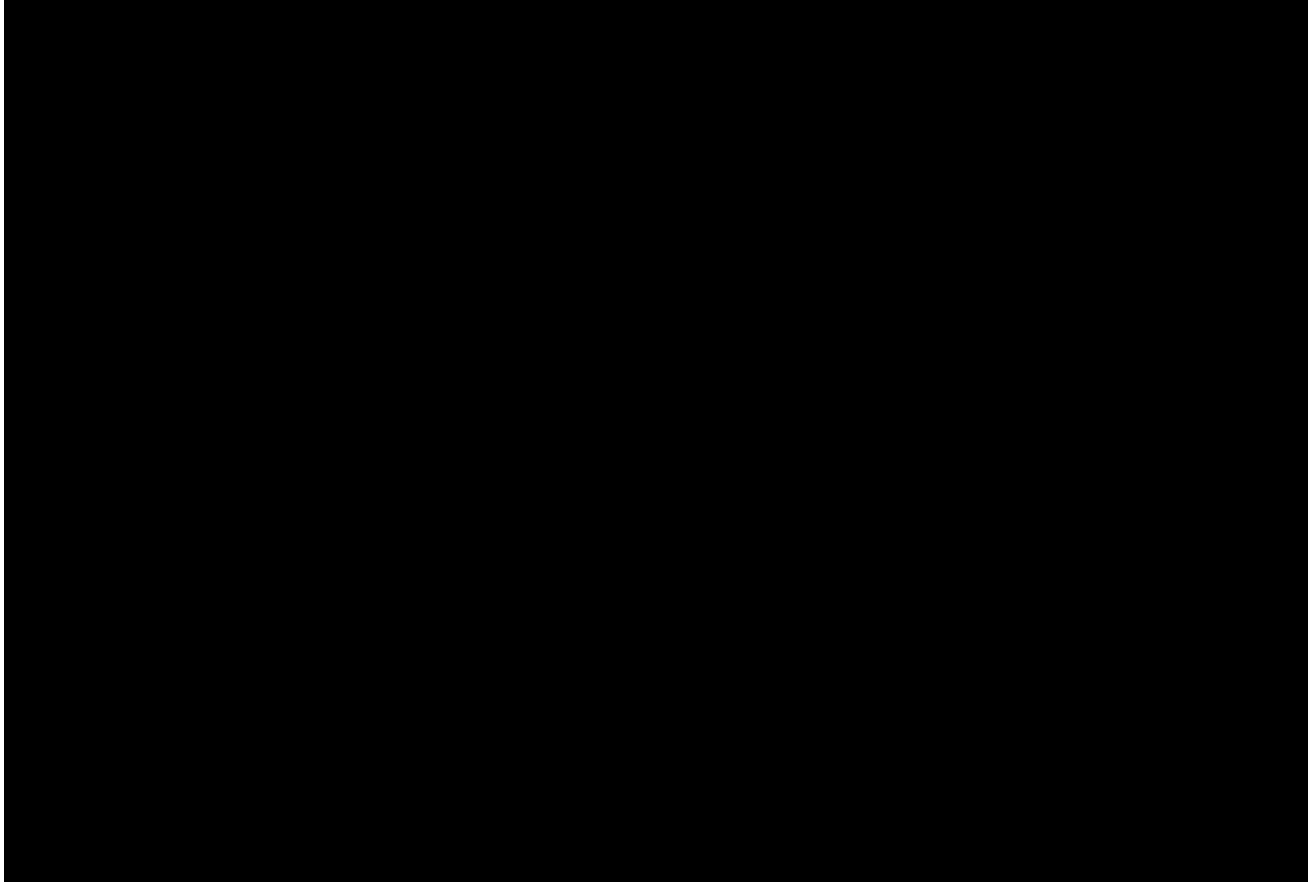

HF IBFS Benefits to the Warfighter

- Provides superior firepower against:
 - Heavy Armor Targets
 - Urban Structures/Bunkers
 - Light Armor Vehicles/Vessels
 - Armed Personnel
- Simplifies logistics and eliminates target/missile incompatibilities by replacing all existing Hellfire Missile variants with a single multipurpose system
- Implements IM explosive and mechanical features to protect the warfighter in hazardous battlefield environments



Questions

Craig Thomas

Mechanical Engineer

850 897 8309 (office)

850 585 5984 (cell)

cthomas@oti.gd-ots.com

General Dynamics Ordnance and Tactical Systems

115 Hart St.

Niceville, Florida 32578