

The Challenge of Environmental Testing of the Expeditionary Fighting Vehicle Ammunition Feed System Separate from the Expeditionary Fighting Vehicle



Presented by:

Ron Hopkins

Staff Engineer

General Dynamics Armament and Technical Products

Williston, Vermont USA

802-662-6213

rhopkins@gdatp.com



Presentation Outline

- Background
- Design Specifications
- Test Setup
- Test Issues
- Summary



Background

- GDATP designed the Ammunition Feed System (AFS) for the Expeditionary Fighting Vehicle (EFV) which is designed by General Dynamics Amphibious Systems (GDAMS)
- The AFS delivers high explosive (HE) and armor piercing (AP) 30 mm ammunition to the MK44 Gun
- The AFS ammunition containers are attached to the floor of the turret basket; the turret basket shelf is attached to the hull of the EFV via a bearing
- The pivoting rollover component of the AFS is attached to the turret shelf
- The turret basket floor is “suspended” from the turret shelf by the support legs

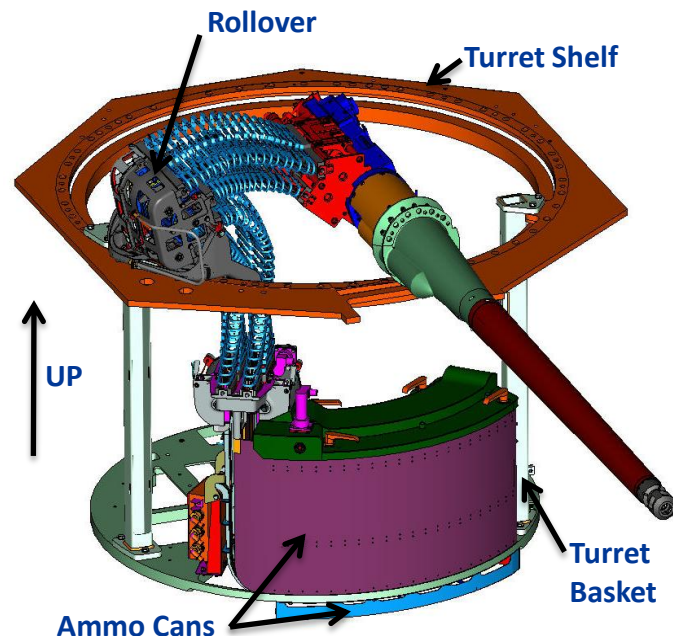



Design Specifications

- AFS Performance Spec – Random Vibration Loads

- Functional loads require demonstration of operability after exposure
- Endurance vibration loads require demonstration of operability during and after exposure
- Random Vibration Loads specified based on location within the EFV
- *Vibration levels are different for items mounted on turret basket floor versus turret shelf*

- Challenge: Operability requirement means testing at AFS level, yet vibration levels are location dependent

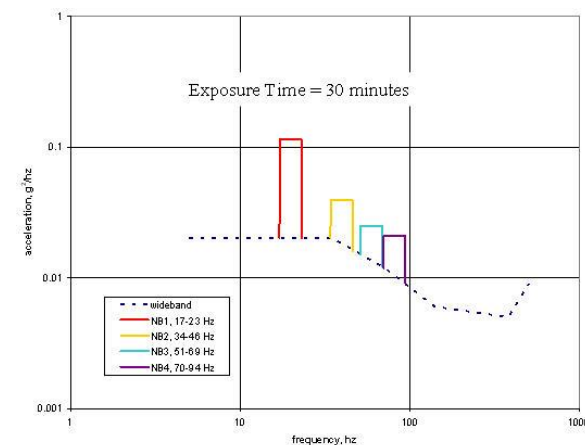



Design Specifications (cont.)

- AFS Performance Spec – Shock Loads
 - Operability must be demonstrated after exposure to each shock
 - Shock loads shall be applied at the turret shelf
 - Shock loads include basic shock, ballistic shock and underwater mine blast
- Challenge is that components at the turret shelf will see shock waveform as applied, however components attached to turret basket floor will see much different waveform as turret basket acts like low pass filter
- Drives the need to develop testing scheme which will best satisfy the performance spec to demonstrate structural integrity and operability of AFS

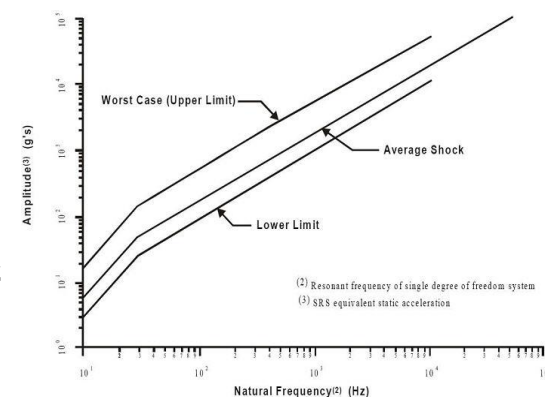



“Ideal” Test Setup

- Incorporate turret basket into test
- Attach turret shelf to shaker with “rigid” test fixture
- Transmissibility between shaker and turret shelf is 1.0 with turret basket providing dynamic filter between shaker head and basket

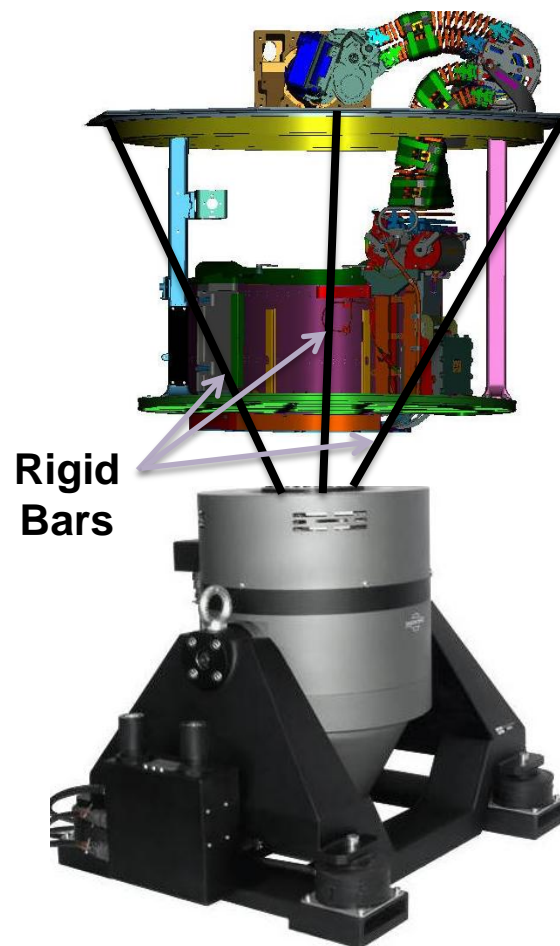



Initial Test Fixture Design

- Initial direction was to design test fixture which provided proper stiffness and position for AFS
- Need “rigid” test fixture between mounting pads and roller over assembly and flexible structure simulating turret basket between rollover assembly and ammo cans
- Must maintain test fixture weight within force capability of shaker – function of acceleration loads
- Conclusion: Could not design test fixture with needed structural dynamic characteristics within weight limitations
- Path forward is to break up testing into two phases

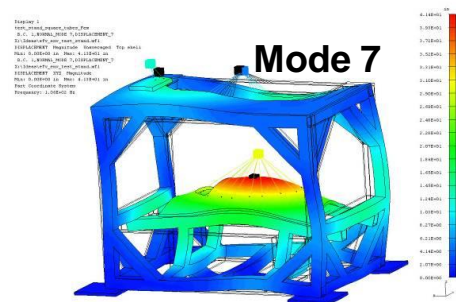
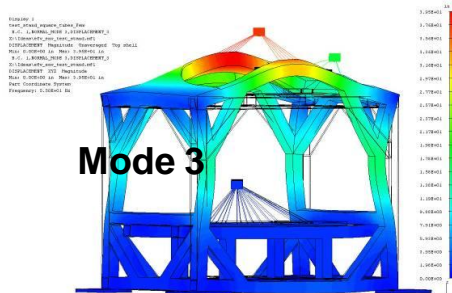
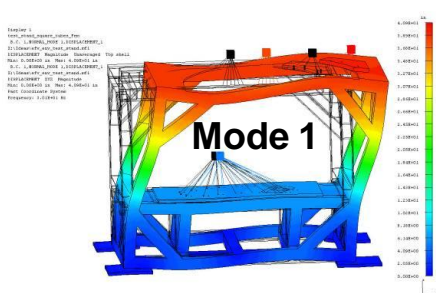
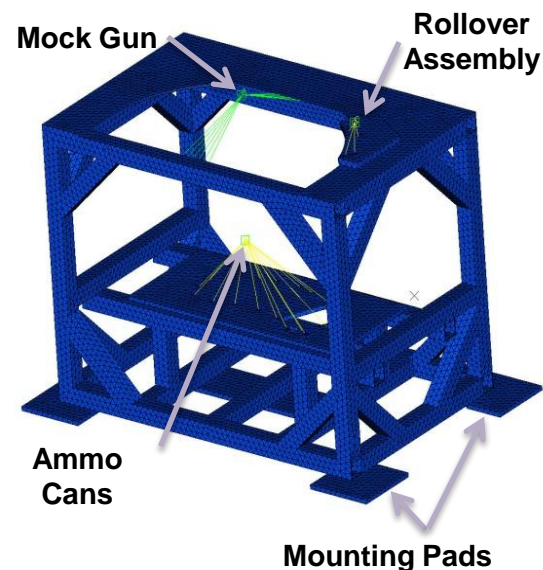

Proposed Test Setup – Rollover Assembly



- First test will expose the pivoting rollover assembly to shock and vibration loads
 - Flexible chuting and linked ammunition will be included to obtain the proper mass and damping effects
 - Shock and vibration loads applied directly as given in performance specification
 - Operability during and after exposure not demonstrated - yet

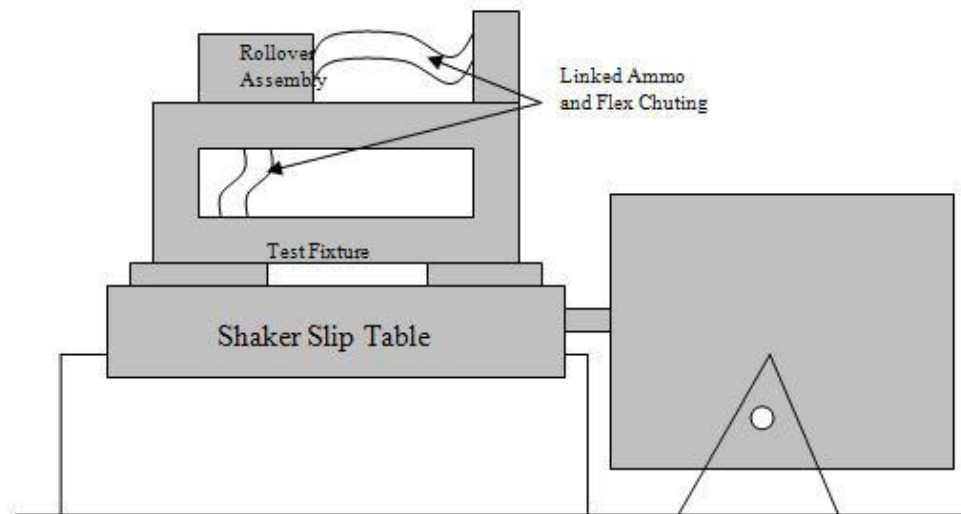

Proposed Test Setup – AFS

- Second test will expose the AFS less the pivoting rollover assembly to shock and vibration loads
- An auxiliary test stand which supports and locates the rollover assembly included but isolated from the shaker
- Flexible chuting and linked ammunition will be included to obtain the proper mass and damping effects
- Operability during and after exposure will be demonstrated and the effects of a rollover assembly previously subjected to shock and vibration loads is accounted for

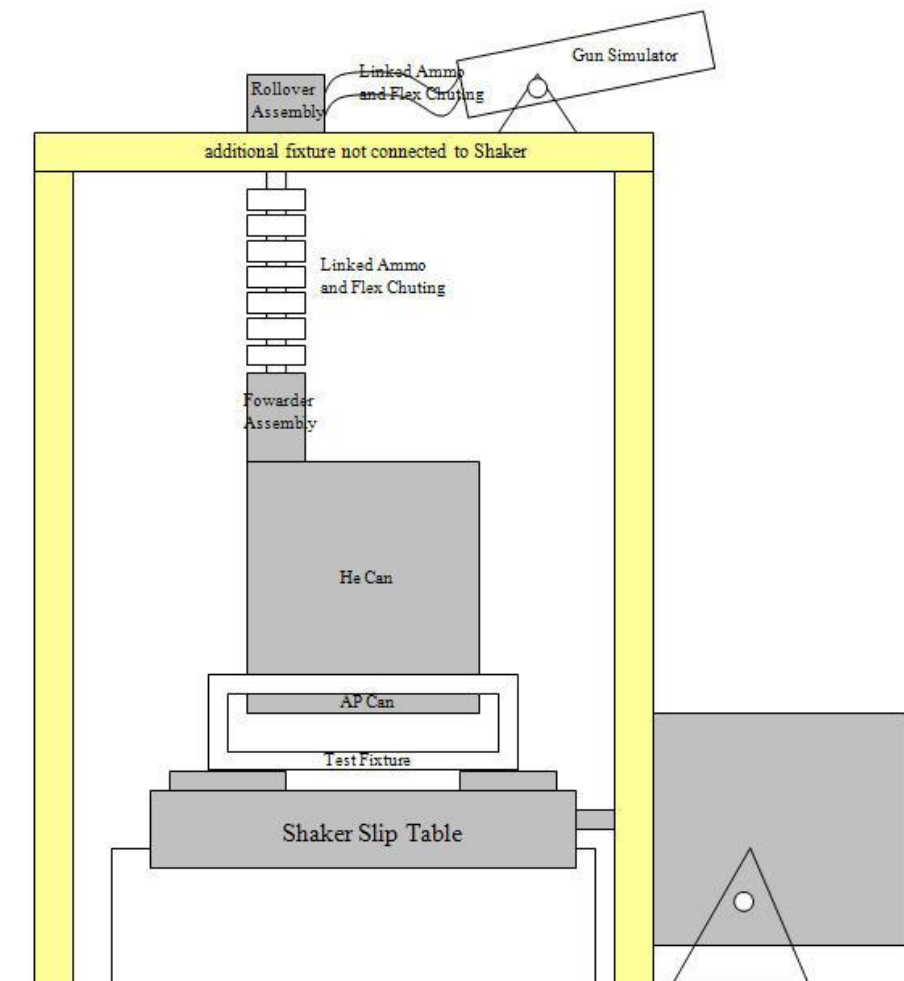



Proposed Test Setup – AFS (cont.)

- Ballistic shock testing at the vehicle level was performed by GDAMS with acceleration levels measured at the turret basket floor
- The shock response spectra for the turret basket floor acceleration will be used as “goal” for the AFS level test
- MIL-STD-810G METHOD 522.1 Procedure V - Limited Spectrum, Medium Weight Shock Machine (MWSM) will be used

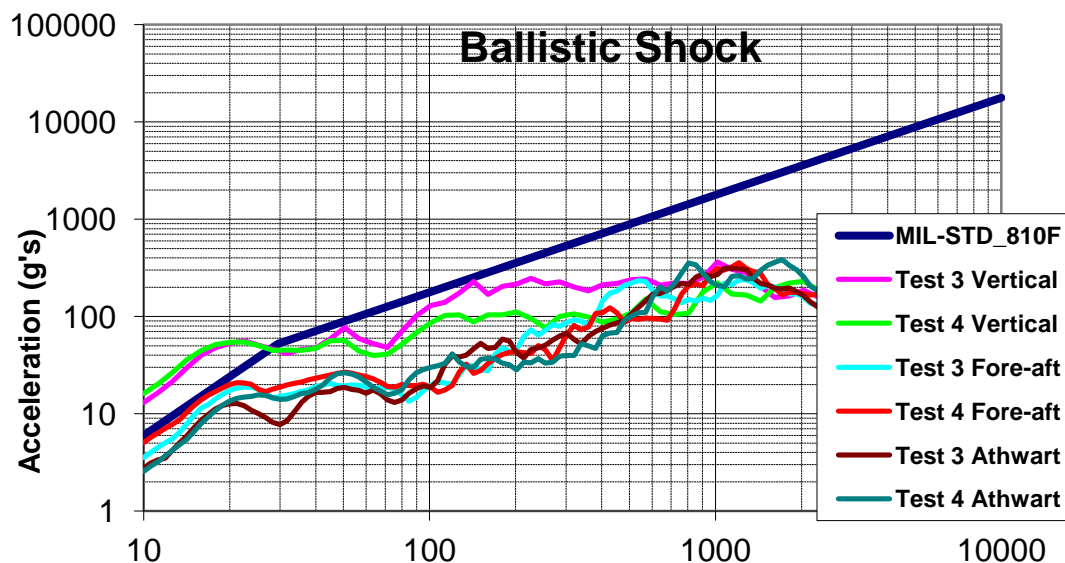

Test Issues



- Some shock loads at the system level cannot be reproduced due to shaker limitations
- Relative motion between pivoting rollover assembly and rest of AFS for demonstration of operability
 - For endurance vibration loads in transverse direction, predicted relative motion between top of ammo can and rollover is 2 inch (3σ) compared to slip table displacement of 1 inch (3σ)
- Stiffness of test fixtures
 - Weight/cost considerations preclude developing test fixtures greater than 500 Hz, therefore feedback control will be needed to develop desired acceleration levels
- Weight of test article and shaker force capability
 - Assumed 5σ acceleration peaks for random vibration load to ensure test article weight did not exceed force capability of largest Dayton T. Brown electro-dynamic shaker

Summary



- Testing methodology to demonstrate structural integrity and operability for the EFV AFS has been developed
- Broken up into 2 phases in order to test to specified load levels
 - First phase exposes pivoting rollover assembly to specified shock and vibration loads but does not demonstrate operability
 - Second phase exposes remaining portion of AFS to shock and vibration loads and demonstrates operability of the complete feed system