



**U.S. ARMY ARMAMENT RESEARCH,
DEVELOPMENT, & ENGINEERING CENTER
(ARDEC)**

***Role of the Government Laboratory in
Shaping Weapon System
Developments; An ARDEC Perspective***

presented to

***46th Annual Armament Systems: Gun & Missile
Systems Conference & Exhibition***

30 August 2011

TECHNOLOGY DRIVEN. WARFIGHTER FOCUSED.



Mr. Anthony J. Sebasto
U.S. Army ARDEC
Picatinny Arsenal, NJ
anthony.j.sebasto@us.army.mil
974-724-6198

- DoD Perspective on Government Laboratories
- ARDEC at a Glance
- Selected ARDEC Examples:
 - Technology
 - New Concepts
 - Manufacturing Processes
 - R&D Experimentation Facilities
 - Partnering with Industry and Academia
- Update on DoD Specialty Site for Guns and Ammo
- Summary



Functions



- Infuse the art of the possible into military planning
- Act as principal agents in maintaining the technology base
- Avoid technological surprise and ensure technological innovation
- Support the acquisition process
- Provide special purpose facilities not practical for the private sector
- Respond rapidly in time of urgent need or national crisis
- Be a constructive advisor for Department directions and programs based on technical expertise (honest broker)
- Support the user in the application of emerging technology and introduction of new systems
- Translate user needs into technology requirements for industry
- Serve as an S&T training ground for civilian and military acquisition personnel



Research



Development



Production



Field Support



Demilitarization



Mission:

Plan and execute integrated life-cycle engineering for the research, development, production, field support and demilitarization of munitions, weapons, fire control and associated items.

By:

- Maintaining strong working partnerships with our customers, other government agencies, industry, and academia
- Advancing our workforce core competencies
- Investing in state-of-the-art equipment and facilities
- Continuously improving our engineering and business processes

To:

- Conduct higher payoff technology research
- Demonstrate novel concepts shaping User requirements
- Develop/resolve manufacturing processes ensuring a robust industrial base
- Support our customers as a “Smart Buyer” addressing technical issues across the life-cycle
- Transition Government Intellectual Property to industry as required

One of the Major Players Shaping Weapon System Developments

Problem:

- Multiple contractors unable to meet requirements for M54A1
- Impacted urgent deliveries of 155mm M110A2 WP Projectile

ARDEC Solution:

- New manufacturing process to maximize production yield
 - Controlled flow with staged cooling process
- Transition equipment /process to industry (Note: Industry declined)
- Provided ~24,000 M54A1s to fulfill need with ~92% production yield

Current Status:

- ARDEC equipment and process successfully transitioned to Crane Army Ammunition Activity (CAAA)
- ARDEC & CAAA collaborated on continuous process improvement
- CAAA has now produced over 29,000 M54A1's now with ~98% yield

M54A1 Burster Tube



ARDEC Burster Tube Equipment

Transition of a New Manufacturing Process to the Industrial Base



Solving Manufacturing Issues *Lead Azide (LA)*



Problem:

- US stockpile only qualified source of LA used in all fuze detonators
- Stockpile 30-40 years old with serious quality issues
- Traditional production process inefficient and start-up unaffordable



ARDEC Solution:

- New low cost “On-Demand” continuous manufacturing process
 - Smaller/safer quantities (flexible, up to 1Kg/day per set-up)
 - Eliminates long-term storage and transportation safety concerns
 - Enables multiple production sites, limiting a single point failure



Current Status:

- Energetic Material Qualification expected Sept 2011
- Material successfully tested in various detonator products
- Transition agreements with Industry on-going



Revolutionizing Industrial Base Processes to Mitigate Single Point Failures



PIF Process

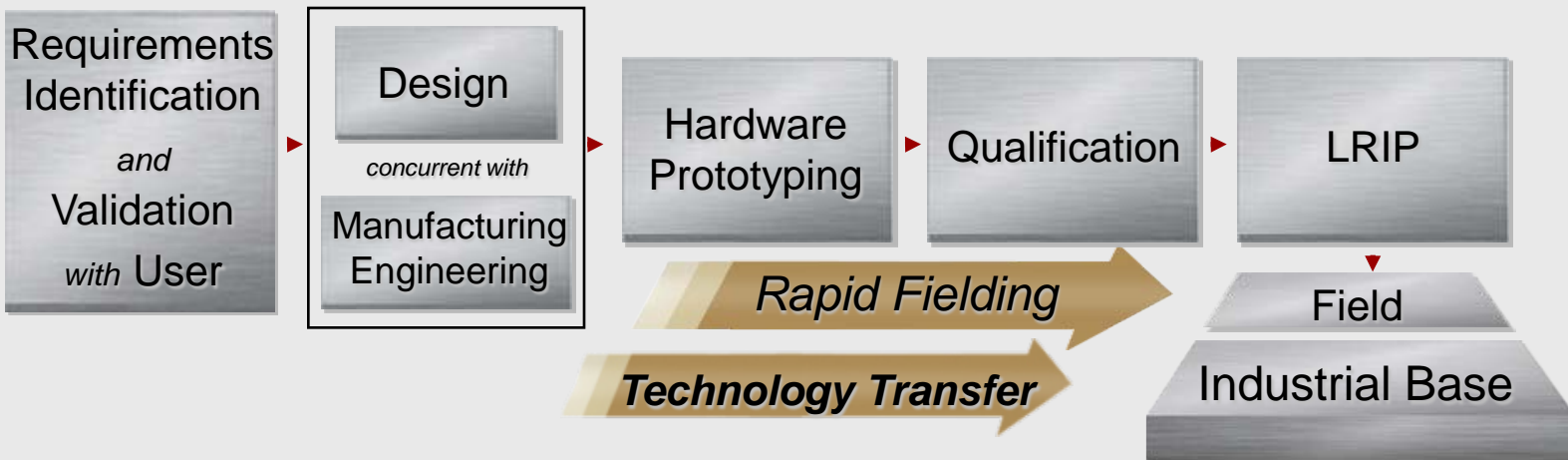

ASTM Titanium Welding Standard

Materials & Manufacturing Science

Pilots with Industry

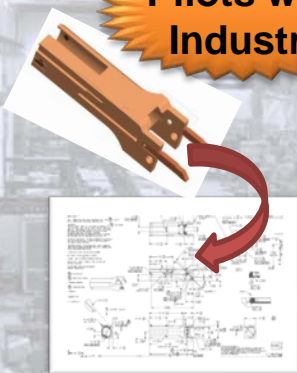

Model-Based Design & Manufacturing

Lean Mfg Cell



Production Process Development

Meeting Urgent User Needs



Concept Development & LRIP



Meeting Customer Demands and Shaping Industrial Base Processes

Automated Direct/Indirect Fire Mortar (ADIM)

Objective: Develop a lightweight, remotely operated automated 81mm mortar expeditionary weapon system for multi-service, multi-mission use

Russian Vasilek 82mm Mortar Weapon



- Rate of fire: 180 rounds/minute
- 4-round "clips"
- Soft recoil (momentum cancellation)

3 Yrs to
TRL 5

ADIM



Exceeds
current 81mm
range

- US Gov't system design
- Rate of fire: 30 rounds/min
- 20-round continuous feed
- Early weapon demonstrator successfully fired 400 rounds (hard stand and HMMWV)

Enabling Flexible Response Capability for Rapid Deployment Needs



Russian 82mm Vasilek Video





Automated Direct/Indirect Fire Mortar (ADIM) *Recent Testing at YPG*





- AMC Chartered Life Cycle Software Engineering Center
- 30+ year legacy of developing & sustaining SW-intensive systems to our warfighters
- 79,000 sq. ft. including SILs and High Bay
- Technology Innovation Leader – Winner 2004, 2006 & 2007 DoD Top 5 Program of the Year
- State-of-the-Art Facilities, Equipment, Tools
- CMMI Level 5 – 2006 First in DoD
- CMMI Level 5 – 2010 Sole Gov't Organization to achieve; only Gov Org to successfully re-appraise

Major Goals:

- Reduce software life cycle costs by identifying and fixing defects closer to phase of origin (requirements, design, code, integration, test)
- Maximize software re-use through common requirements, common solution, and enhanced products and capabilities



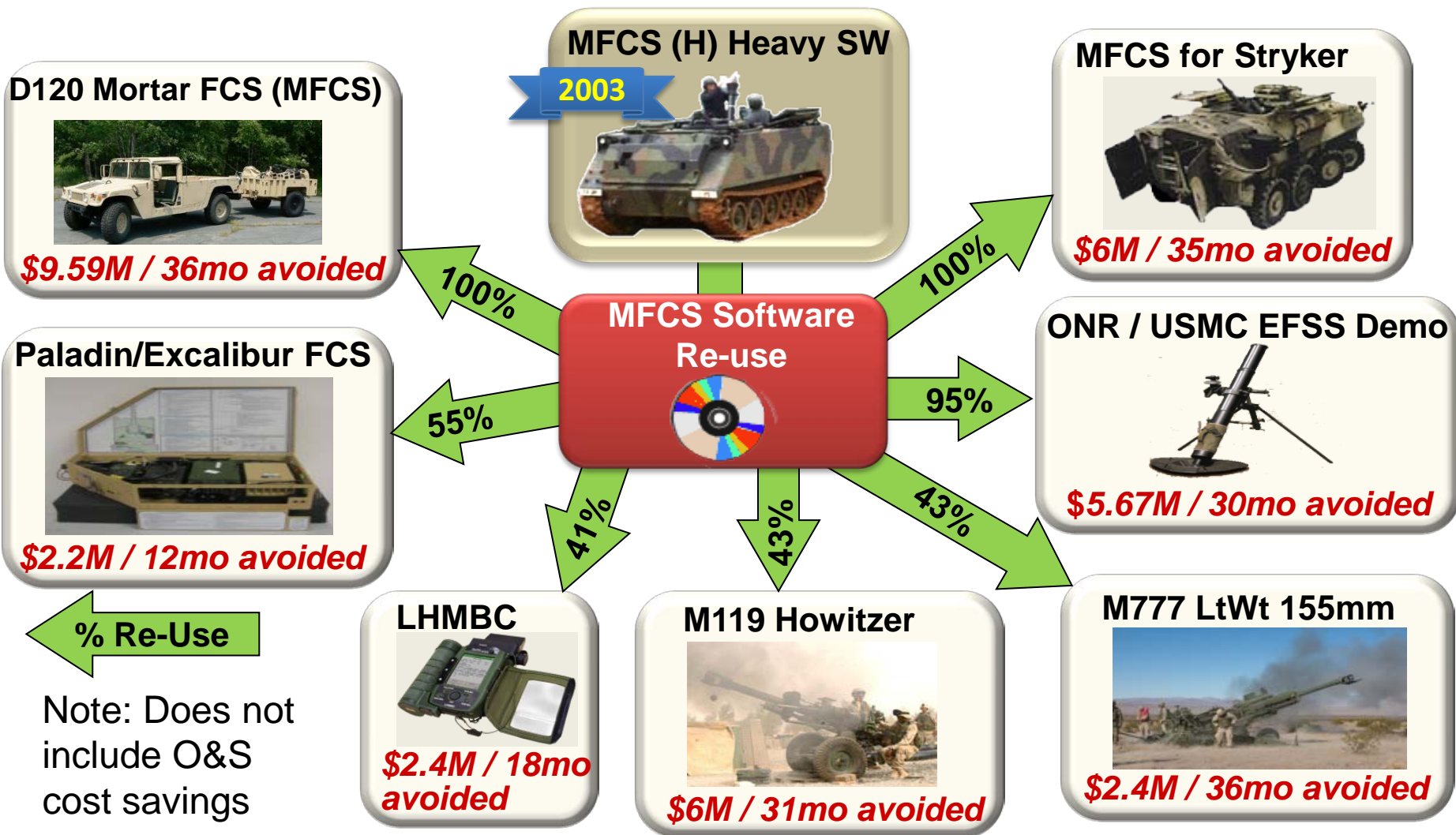

Flexible Architecture Enabled 40-100% S/W Re-Use Across Multiple Applications

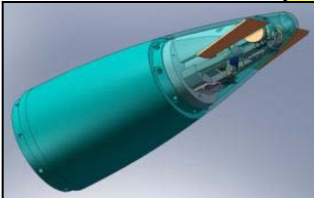

- Gov't (ARDEC/ARL) integrated design & GnC for indirect fire
- Goal: UPC \$10K (Full-Up 155mm)
- Demonstrate scalability across multiple calibers

**Challenge from
the Acquisition
Community**

Forward Single-axis Canard for Control system

120mm VAPM



- Gov't deployable flip-back fin design
- Successful Guide-to-Hit Test March 2010
 - 9.8m miss distance from target at 3.8km

155mm VAPP



- Same GnC with modified canards for 155mm
- Successful Guide-to-Hit Test July 2010
 - <10m miss distance at 16.4 km

105mm VAPP

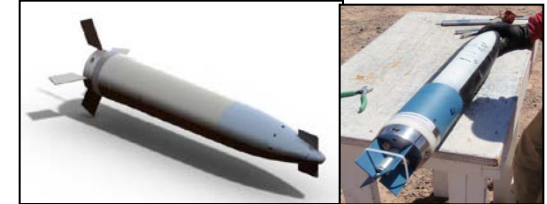

- Gov't folding fin design
- Preprogrammed maneuver test completed Dec 2008
- Guide-to-Hit test planned FY12

Gov't Owned Common Technology Approach Across Multiple Applications Available to Industry to Reduce Development and Unit Costs

Game Changing Technologies

Gun Launched MEMS Safe & Arm Fuzing



2000

2005

2010

20/25mm Air Burst
MEMs S&A



Technology and
Manufacturing Development
to TRL6 / MRL7

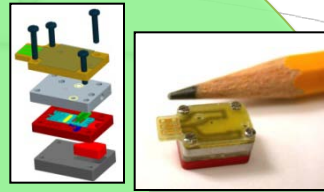

MEMS S&A
MANTECH

MEMS "G-Switch" Firing Test



M762A1 S&A for ARTY

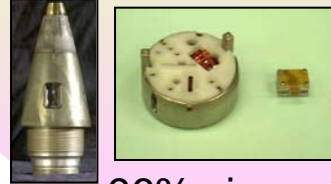

96% size reduction

Successful
Gun Firing

40mm MEMS S&A
Tech Transition Initiative

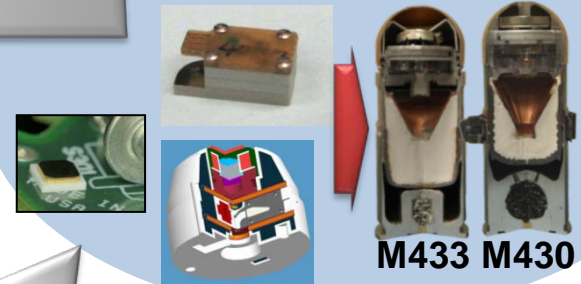

M433 M430

MEMS Impact
"G-Switch"

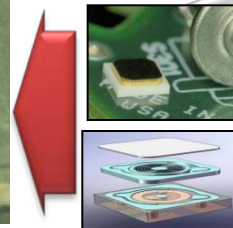

- Reduced S&A size/weight
- Higher reliability in graze & soft target impact
- Micro-Scale Firetrain demo'd
- Transitioned to PM 2QFY11

Pushing Emerging Technology for Performance, Reliability, and Affordability Gains



Game Changing Technologies

Scalable Effects Technologies

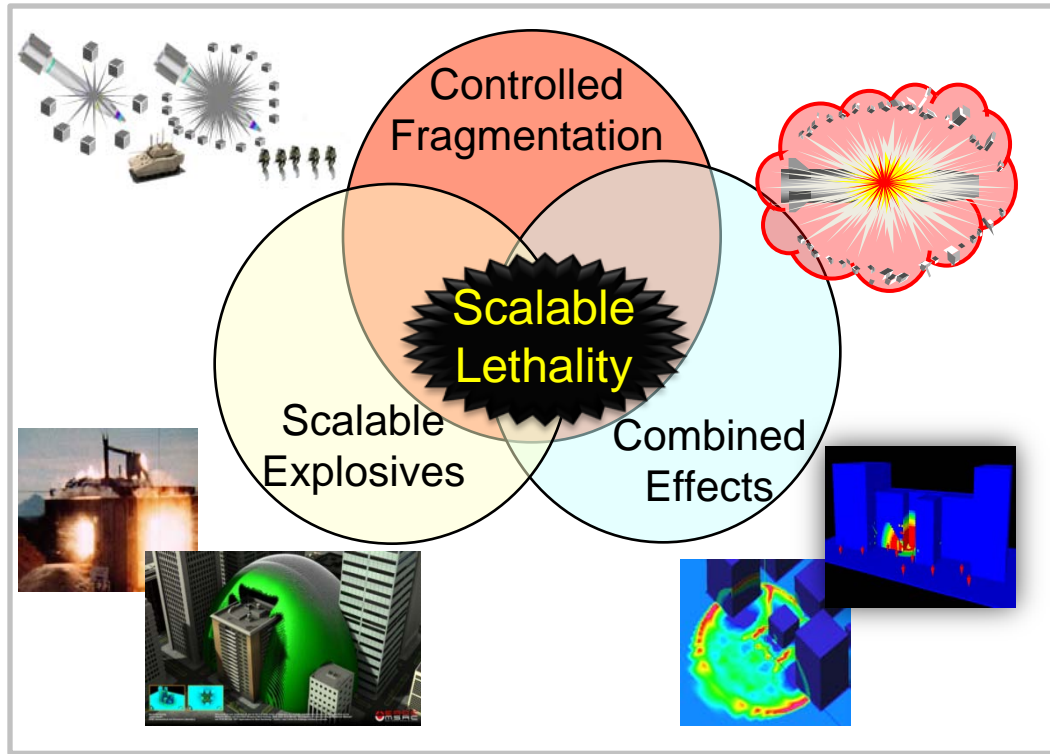

- More engagement options
 - Improves Weapon Effectiveness
 - Reduces Collateral Damage
- Enables military operations in complex environments
- Demonstrations planned Oct/Nov

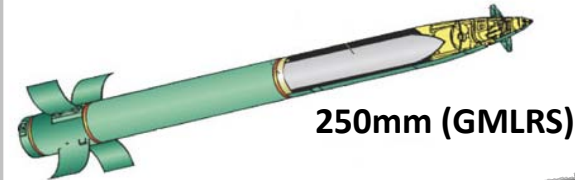

Current Munitions

Scalable Munitions

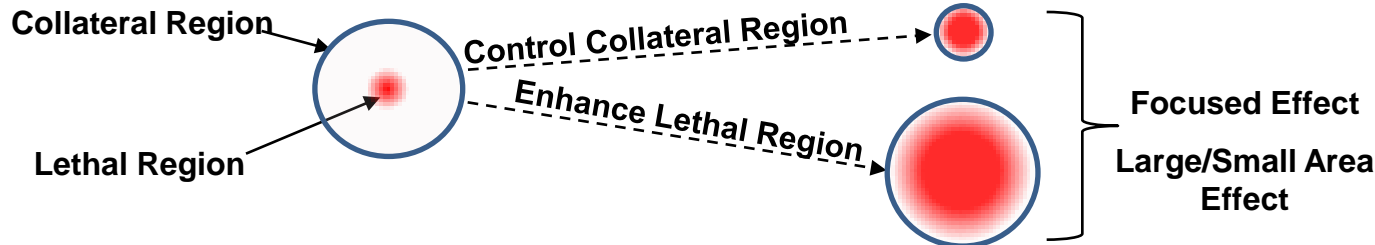

Demonstrations to help User/Developer community shape path forward



Induction Plasma Reactor

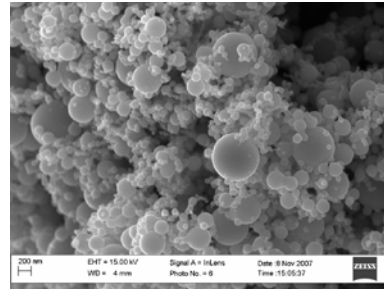

High Energy Milling

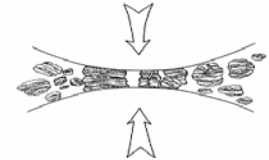
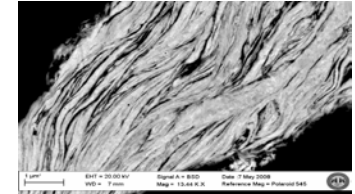

- \$10M in facility investments since 2002 enabling:
 - Material quantities for Applied Research
 - Development and characterization of manufacturing processes for nano and nano-structured materials
- Processing capabilities for both metals and ceramics
- Up to 1Kg/hr yield
- Full characterization capability of nanomaterials
- Multiple Government, Industry, and Academia customers/partners for material supply and applications

Examples of materials made:

- Aluminum/Al alloys
- Copper/Cu alloys
- Magnesium/Mg alloys
- Silicon
- Tungsten
- Iron
- Boron
- Boron Carbide
- Cerium Oxide

Accelerating R&D of Nanotechnology Applications to Armaments





Sintering Technology



Isostatic Pressing

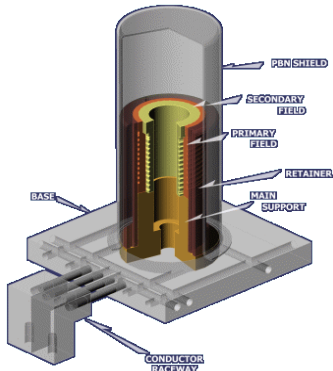

Enabling:

- Near-Net Shape components
- Lighter and stronger materials
- Functionally Graded Materials
- Improved output performance
- Manufacturing process development



Reduced Manufacturing Times/Costs for the More Complex Components





Industry

Training Partnerships

Gov't Labs Tools & Model

Industry M&S Tools

PRO-E

GLO/CALE

ABAQUS

ANSYS

Weapons Dynamics

ALE3D

LS-DYNA

Exterior/Terminal Ballistics

MSC.ADAMS

Component Design

FLUENT

PRESTO

Interior Ballistics

CTH

PRODAS

Cheetah

PAFRAG

Product Improvements
(e.g. Cluster Munition Replacement)

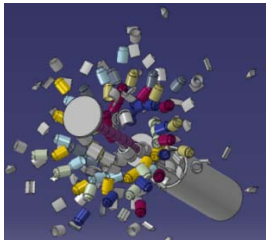

Failure Investigation (M789)



Novel Designs
(e.g. VAPP)

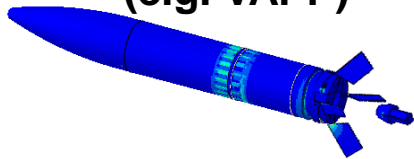

Production Flaw Behavior Analysis (M20A1)

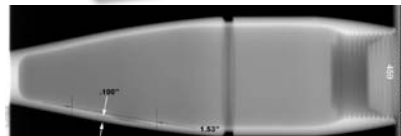

Failure Investigation (M777)



Setting the Standard on Applications of High Performance M&S
Solving and Preventing Anomalies Across the Life-Cycle





Special Purpose Facilities

ARDEC Soft Catch (SCat) Gun



- ~\$10M investment
- Operational in 2007

- Non-destructive, soft catch of gun fired conventional, and smart munitions, sensors, guidance, and fuzes
- Current configuration fires any 155mm projectile
- Eliminates expensive and time consuming iterations of open-range, destructive testing
- Reduces experimentation/testing costs (>80%)
- Over 380 shots to date supporting both Government and Industry customers (IMUs, GPS, Full-up GnC, Variety of Electronic Components, etc.)

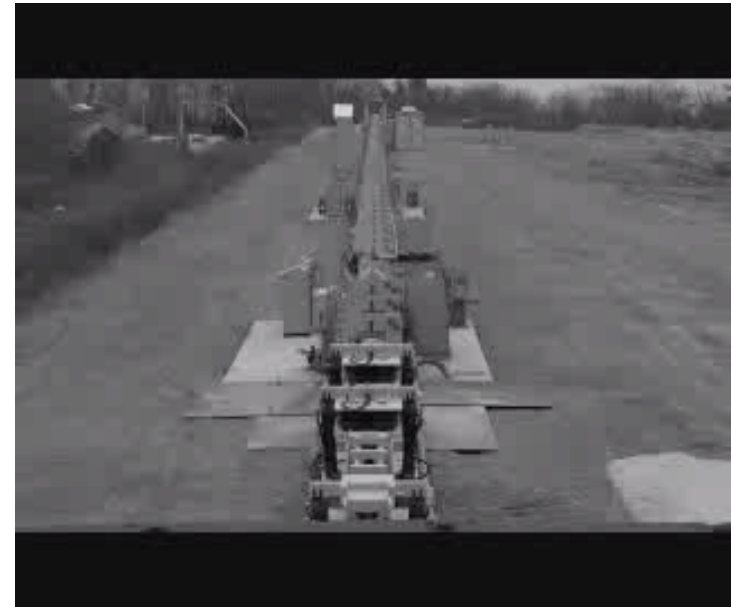

Unique Facility Significantly Reducing Development Cycle Times/Costs





- Promoting strong partnership with industry/academia
- Section 845 Other Transaction Agreements (OTA)
- Includes Traditional and non-traditional industries and academia

DoD Ordnance Technology Consortium (DOTC)



**Government
Laboratories**

**National Warheads
& Energetics
Consortium**

- Established 2000
- ~170 members in NWECC
- “Customer Push” emphasis on investments
- >\$500M awarded since inception

National Small Arms Center (NSAC)

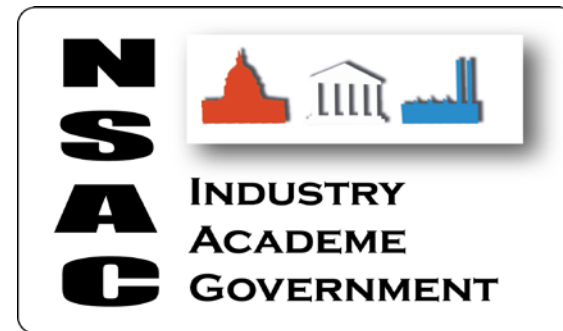











- Established 2004
- ~100 members in the National Small Arms Technology Consortium
- “Supplier Push” emphasis on investments
- ~\$23M awarded since inception

Increasing Business Efficiency and Effectiveness of Solutions to Meet Warfighter Needs

Update on DoD Specialty Site for Guns and Ammo



- BRAC 2005 Law designated Picatinny Arsenal, NJ as an *“Integrated Weapons and Armaments Specialty Site for Guns and Ammunition”* effective 15 Sept 2011
- Involves moves from both Navy (240 positions from NSWC and NAWC) and Army (43 positions from ARDEC (Adelphi)); Picatinny Navy element part of NSWC-IHD
- \$71M construction on new/renovated facilities nearing completion
- Service Guns and Ammo labs will begin to examine approaches to increase effectiveness and efficiency of weapon system developments in a Joint environment

Navy				Army
Auto Gun Test Facility 	Turret Facility 	Minor Caliber Weapons Systems Lab 	Packaging, Handling, Storage and Transportation Center 	Fuze Engineering Complex 
				

- Functions of the Service labs driven from the top
- ARDEC is helping shape weapon system developments across our life-cycle engineering mission
 - Game-changing technologies and concepts for performance, reliability, functionality, and affordability
 - New/updated manufacturing processes ensuring a robust industrial base
 - New facilities reducing development and production times and costs
 - Promoting strong partnerships
 - Answering the call of our many acquisition customers!
- DoD Specialty Site for Guns and Ammo provides the setting for more collaborative developments and business process enhancements across DoD
- Gov't Labs: One of the Major Players Shaping Weapon System Developments