

Joint Service Power Expo 2011

Small Unit Power Requirements



Purpose

- Look at the Company and small unit power requirements
- Look at the camp structure in Afghanistan in relation to unit power requirements
- Review the alternative power equipment currently fielded to support Company sized units
- Impact of Renewable Energy Systems
- New requirements / opportunities

Marine Air-Ground Task Forces

- Marine formations deploy as integrated MAGTF's of various sizes. The MAGTF brings Air, Ground, and Logistics support elements with them.
- There are four core elements of the MAGTF.

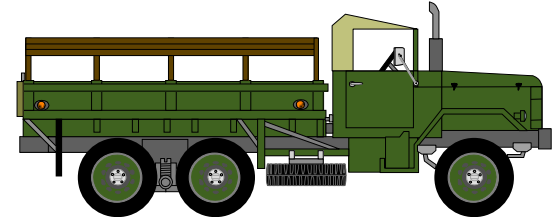
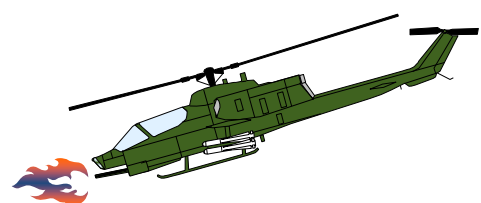
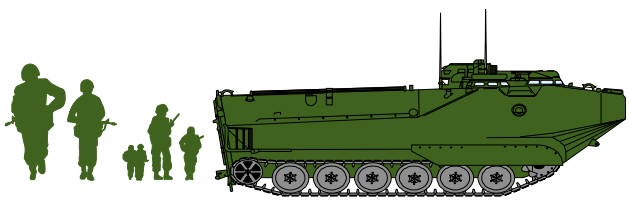
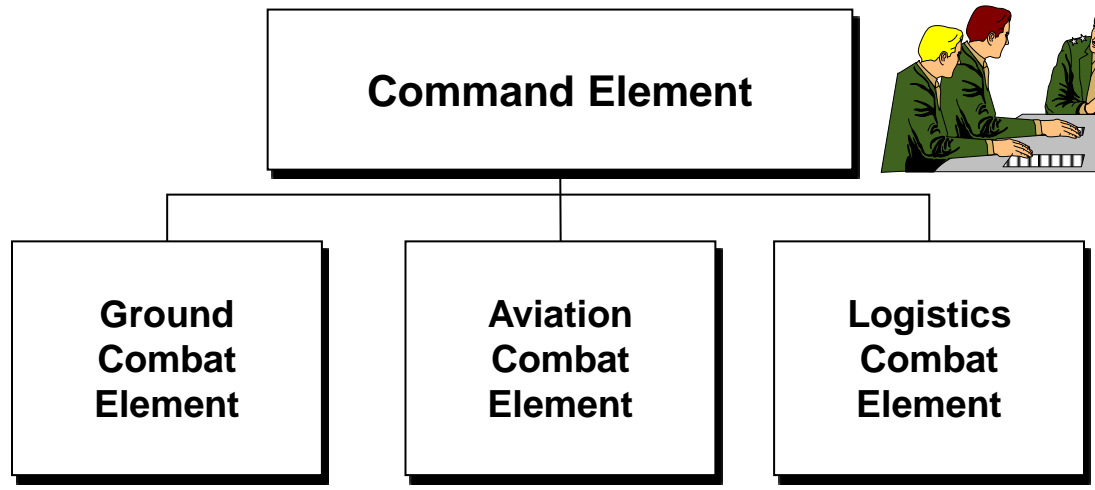

Marine Air-Ground Task Forces

- Power requirements depend on the size of the MAGTF and the size of the MAGTF is tailored to meet the needs of the mission.

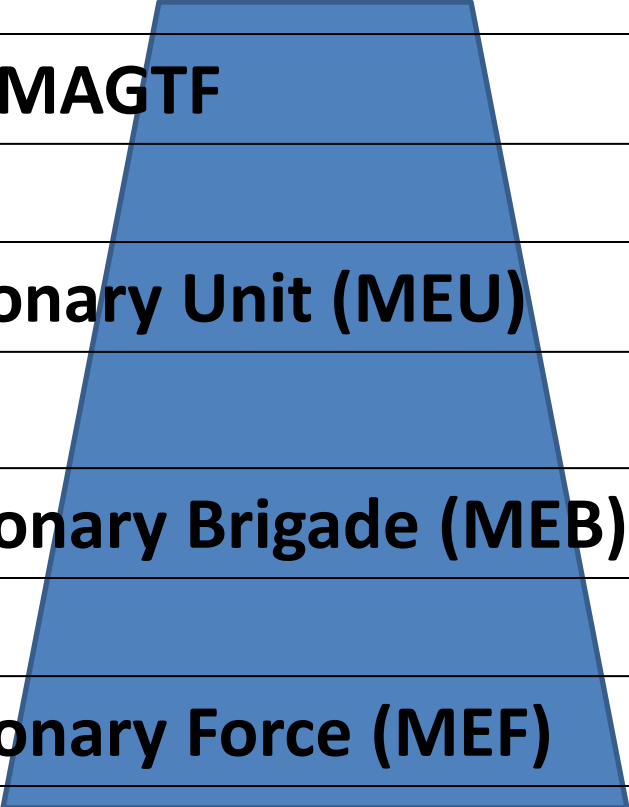

Special Purpose MAGTF	As required
Marine Expeditionary Unit (MEU)	1500-3K Marines
Marine Expeditionary Brigade (MEB)	3-20K Marines
Marine Expeditionary Force (MEF)	20-90K Marines

MAGTF Elements and Camps

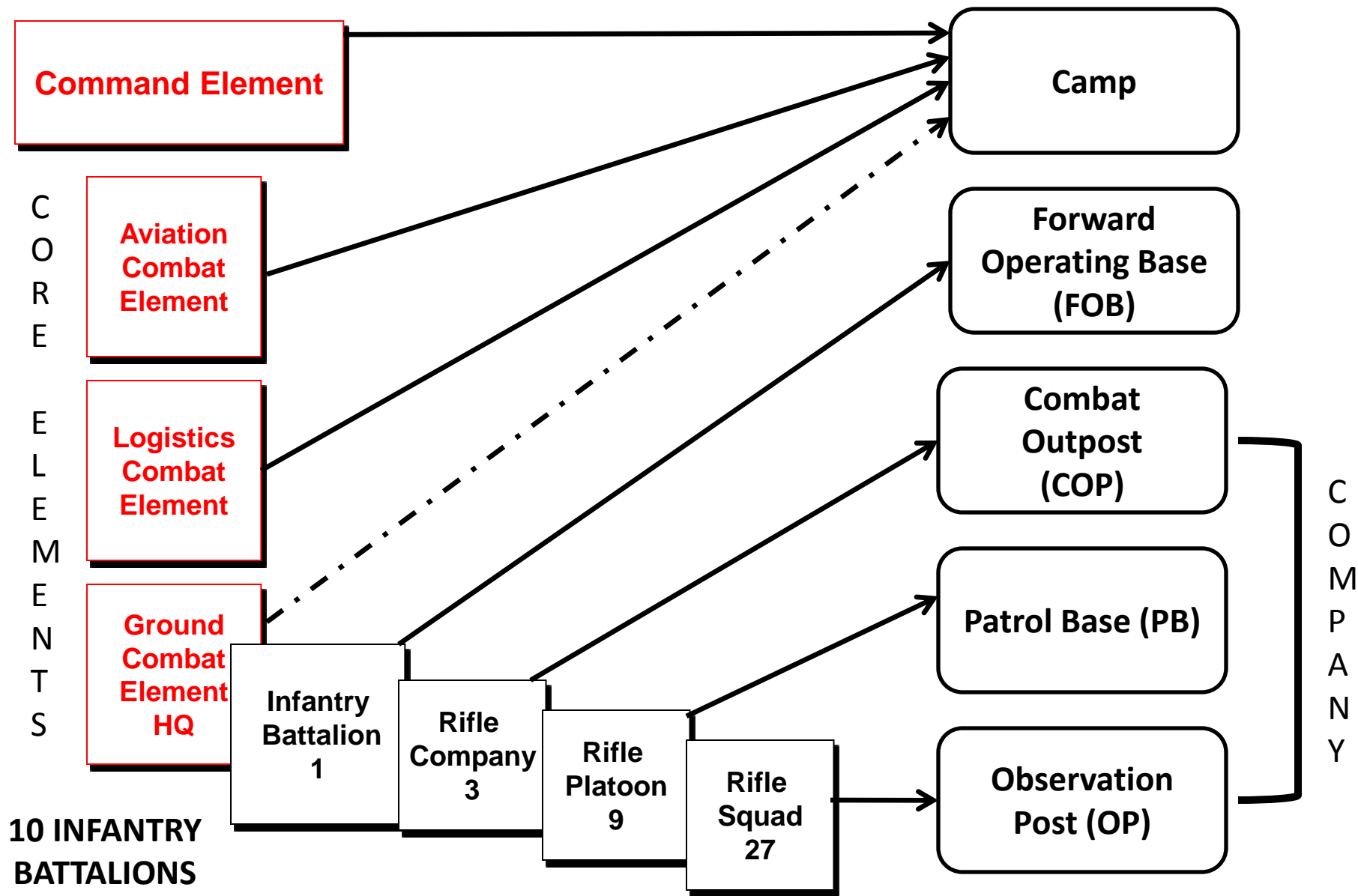

The Entry Point

Forward Operating Base

**FOB
LEATHERNECK**

**Marine
Expeditionary
Brigade**

**3 Infantry
Battalions**

The Entry Point

Forward Operating Base and Camp



Command Element

**CAMP
LEATHERNECK
MEF (FWD)**

**Aviation
Combat
Element**

**Logistics
Combat
Element**



**Ground
Combat
Element**

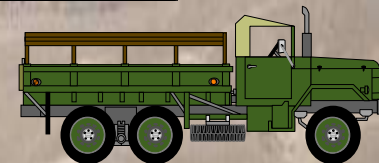
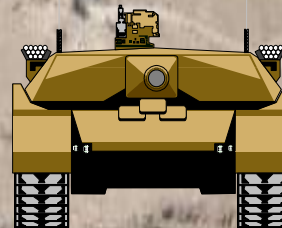

Characteristic's of the Expeditionary CAMP

- Mobile Electric Power readily available
- Tactical vehicle support readily available
- Airfield
- Hospital
- Large logistics support facilities



Extending Forward Presence with the Forward Operating Base

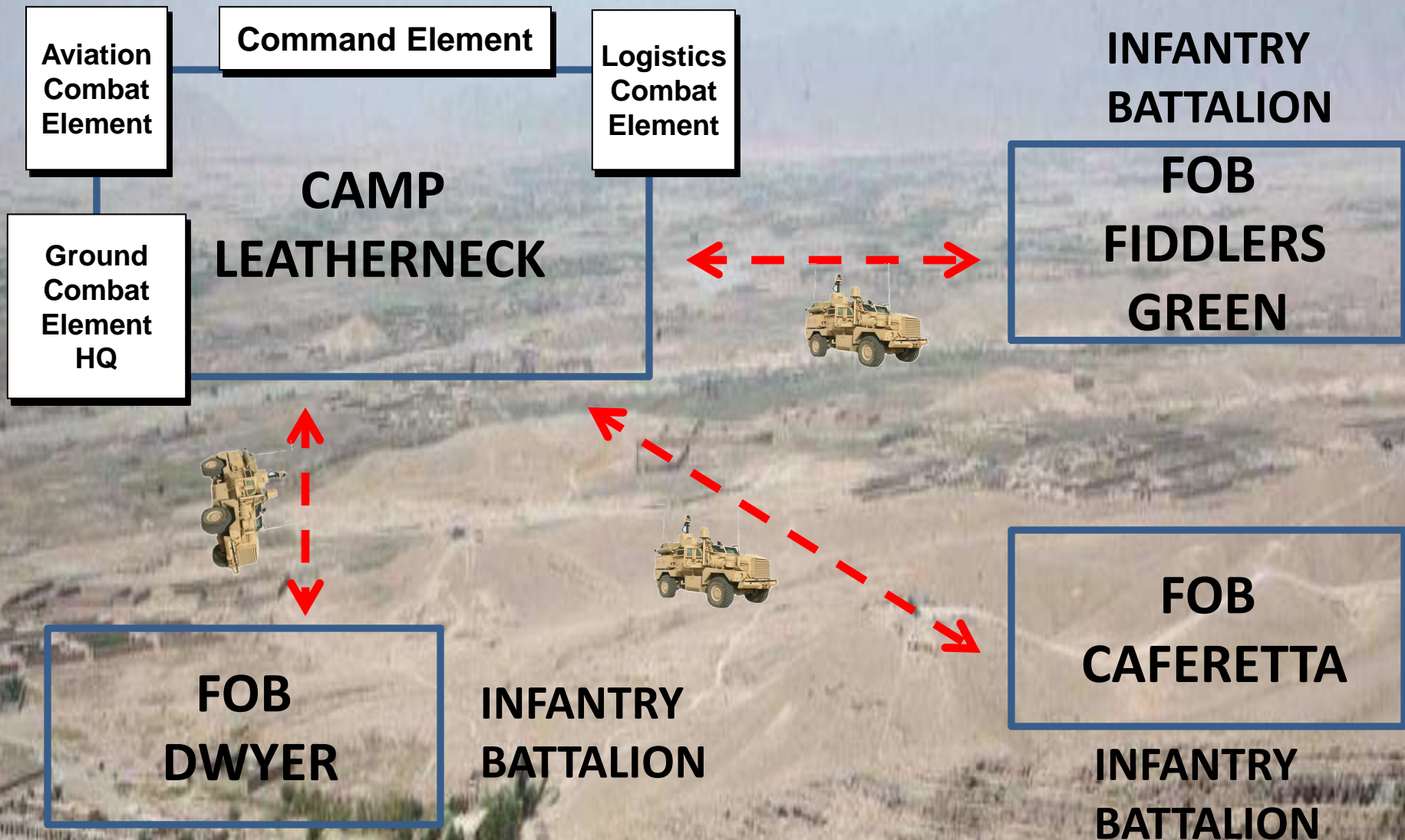

Tactical Convoys remain at risk to IEDs

Eliminate bottled drinking water

- Increase use of local water sources

Reduce high fuel consumption

- Optimize efficiency of generators
- Minimize waste of power and water
- Reduce overall power demand
- Employ renewable energy technologies

Standard CLB-8 Tactical Logistics Convoy

- Thirty percent (6 of 20) vehicles are for force protection
- Only one vehicle used for fuel
- Thirty-five percent (7 of 20) vehicles are for bottled water transportation

FORCE PROTECTION



MRAP

MRAP

MRAP

MRAP

WRECKER



FUEL

Resupply on the way



MRAP pushes a mine roller during a five-day convoy to provide resupply. During one resupply convoy it took nearly 40 hours to travel a mere 70 miles.

Characteristic's of the FORWARD OPERATING BASE

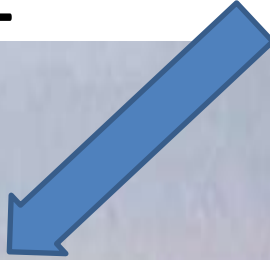
- Battalion sized organization
 - Mobile Electric Power readily available
 - Tactical vehicle support readily available
 - May contain an airfield or FARP
 - Limited medical support
 - Limited utilities personnel for generator support / planning
 - **Provides logistics support to COP's**
- 

Forward Operating Base (FOB) and Combat OutPost (COP)

**FOB
CAFERETTA**

**RIFLE
COMPANY**

**INFANTRY
BATTALION**

**COP
PAYNE**

**To reduces reaction
time and increase
time on task
Battalions establish
Company sized COPs**

**RIFLE
COMPANY**

**COP
QUELETTE**

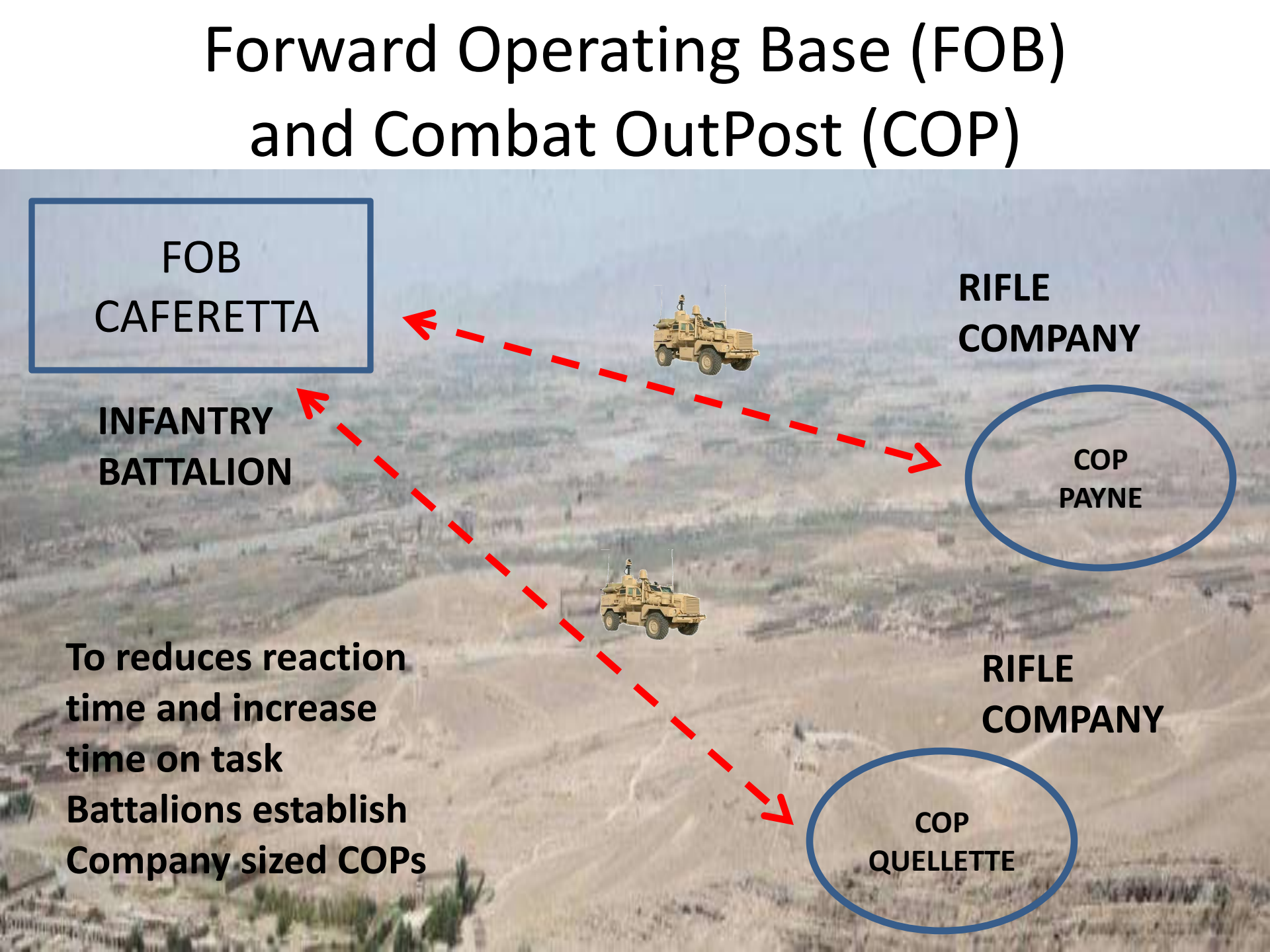

Characteristic's of the COMBAT OUTPOST

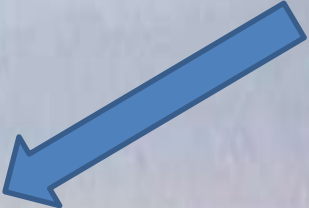
- Company sized organization
 - Limited generator support (2kW to 3kW)
 - Lack of trained generator mechanics
 - Few generators running at optimal levels
 - Unsupported commercial generators result in frequent loss of power
 - Limited Tactical vehicle support
 - Dependent on resupply from supporting FOB
 - **Increased reliance on primary batteries**
- 

Primary Batteries and Re-supply

- Weight. 2 DOS battery load is 100-120 pounds, on average, 20 Lbs. per Marine in addition to combat load.
- Re-supply. Ties patrol to LOC's limiting abilities to push into enemy territory. Completely stalls operational momentum.
- Cost. One BA-5590B/U costs \$60.00.
- II MEF FY10 BA-5590 costs = 2.1 Million \$
- Not always available. BA-5590B/U battery demands during OIF-1 (April – May 2003) peaked at 330,000 batteries per month and backorders quickly rose to over 900,000.



To reduce dependence on primary batteries you must have the capability to charge and maintain rechargeable batteries











SQUAD

PLATOON

COMPANY
COP

BATTALION
FOB

PATROL BASE / OBSERVATION POST

			
PRIMARY BATTERIES			
			
			GENERATORS (2-3kW)
			
			VEHICLES
			
			RECHARGEABLE BATTERIES
			
			BATTERY CHARGERS
			
			INVERTERS
			
			24V RADIO POWER ADAPTERS

SQUAD

PLATOON









COMPANY

BATTALION

PATROL BASE / OBSERVATION POST

COP

FOB

			
PRIMARY BATTERIES			
			
			GENERATORS (2-3kW)
			
			VEHICLES
			
			RECHARGEABLE BATTERIES
			
			
			BATTERY CHARGERS
			
			INVERTERS
			
			
			24V RADIO POWER ADAPTERS

SQUAD

PLATOON









COMPANY

BATTALION

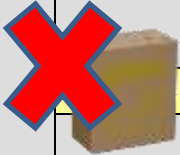
PATROL BASE / OBSERVATION POST

COP

FOB

SQUAD	PLATOON	COMPANY	BATTALION
			
PRIMARY BATTERIES			
			
GENERATORS (2-3kW)			
			
VEHICLES			
			
RECHARGEABLE BATTERIES			
			
BATTERY CHARGERS			
			
INVERTERS			
			
24V RADIO POWER ADAPTERS			

Ground Renewable Expeditionary Energy Network System (GREENS)

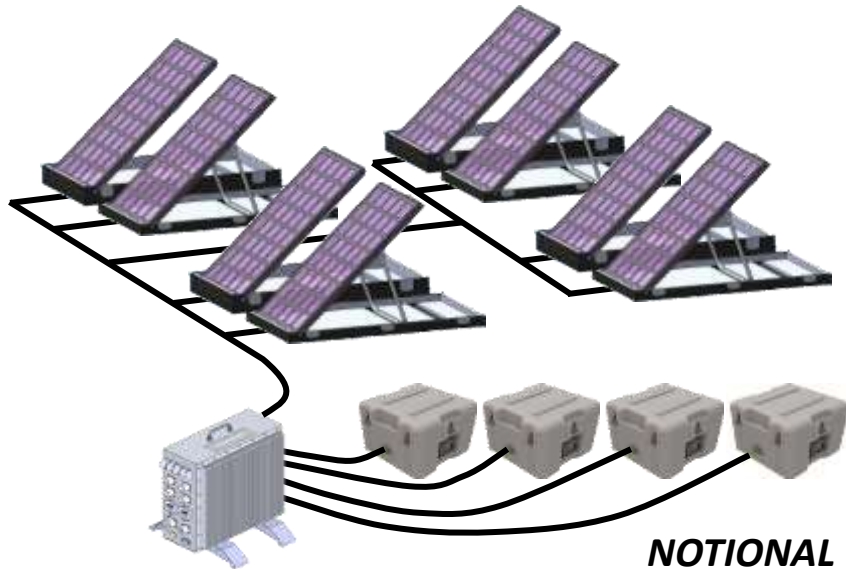

Capabilities Description

- Man-transportable devices with renewable energy collection and storage that can energize Comm-Elect equipment, sensors, and radios

Technical Description

- Man-portable components
- Electrical output: 300 watt continuous 24 / 7
- 24 VDC output
- Key Components:
 - Batteries, Controller, and Energy Input sources



Solar Panel Durability – PB Gombadi

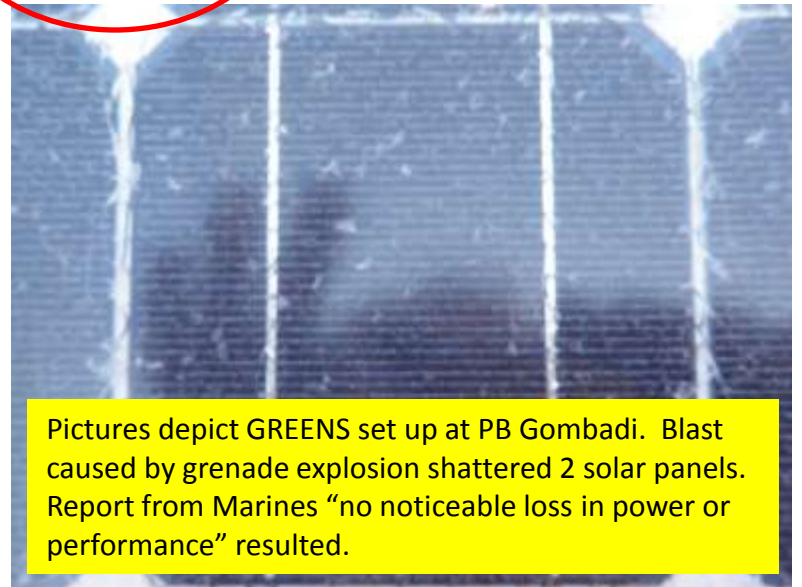
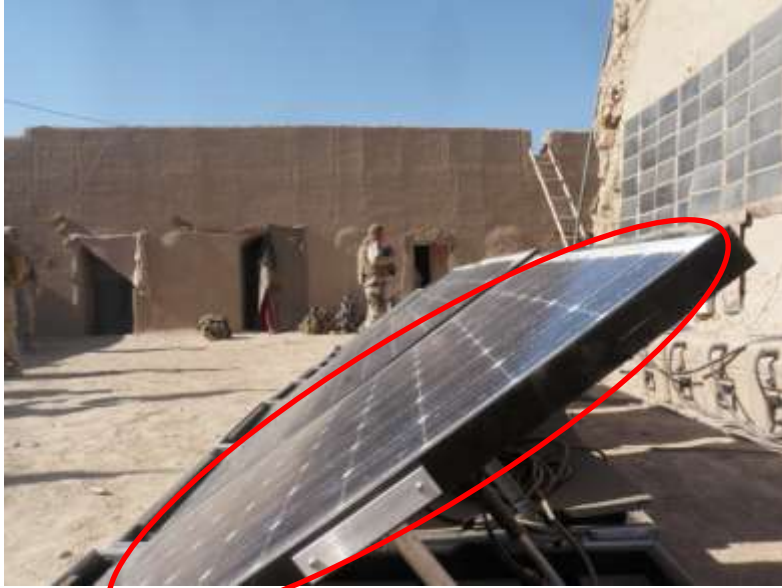

Pictures depict GREENS set up at PB Gombadi. Blast caused by grenade explosion shattered 2 solar panels. Report from Marines "no noticeable loss in power or performance" resulted.





SQUAD

PLATOON

COMPANY
COP

BATTALION
FOB

PATROL BASE / OBSERVATION POST

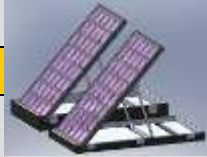
	PRIMARY BATTERIES		
			GENERATORS
	RECHARGEABLE BATTERIES		
BATTERY CHARGERS			
<p>COPS require a mix of Renewable Energy and Legacy Systems</p> <p>Renewables can completely power PBs and OPs</p>			
			24V RADIO POWER ADAPTERS
	GREENS		GREENS
Fielded or being fielded		Still in development or next Generation	











SQUAD

PLATOON

COMPANY
COP

BATTALION
FOB

PATROL BASE / OBSERVATION POST

	PRIMARY BATTERIES		
			GENERATORS (2-3kW)
			RECHARGEABLE BATTERIES
			BATTERY CHARGERS
			
			GREENS
			INVERTERS
			OBVP
Fielded or being fielded		Still in development or next Generation	



On-Board Vehicle Power

SQUAD

PLATOON

COMPANY

BATTALION

INVERTERS			INVERTERS
			OBVP
Fielded or being fielded		Still in development or next Generation	



QP-1800



OBVP - HMMWV



OBVP - MTVR

EMV 5-10 After Action Kilo Company 3/5



- Kilo Company has been using a running M1114 with an A/C inverter to support power requirements for their COC. **The power demands have taken a mission critical gun truck out of the fight.**
- The **vehicle was not designed to run in idle for days.** This can put wear and tear on the vehicles components (engine, alternator, battery...) requiring maintenance.
- The exact fuel consumption of a M1114 is unknown but an estimated figure is 5 gallon/day in idle . It has a 21 gallon tank and needs refuel about every 3-4 days.

On-Board Vehicle Power HMMWV

30 kW stationary

10 kW On-The-Move

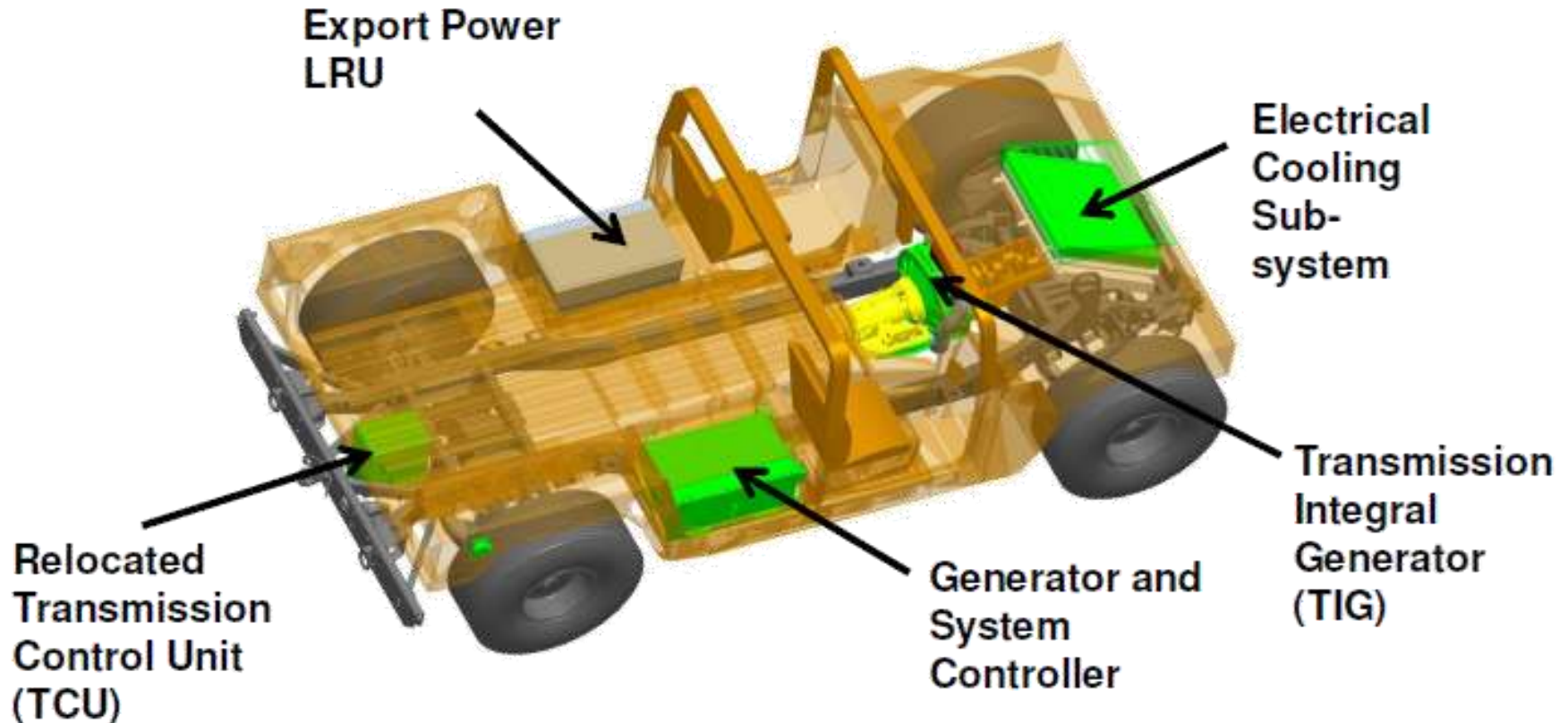

Add generator between engine and transmission
QTY 15 to be delivered by the end of CY11

On-Board Vehicle Power MTRV

120 kW stationary
21 kW On-The-Move

**Engine Driven Generator
(replaces Allison transmission)**

High Voltage Box

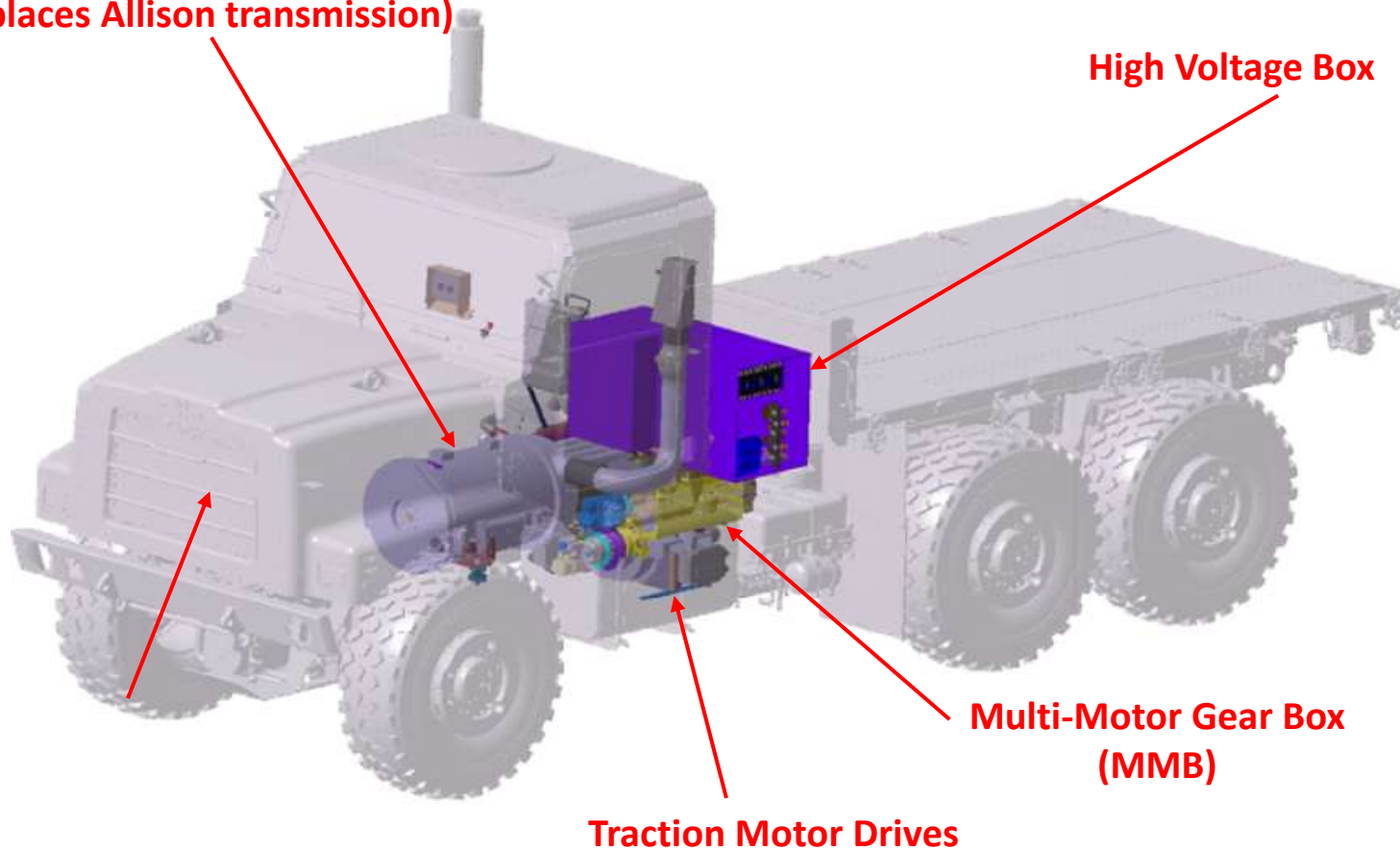

**Multi-Motor Gear Box
(MMB)**

Traction Motor Drives

Replace transmission with engine driven generator
QTY 6 to be delivered by the end of CY12

Combat OutPost (COP), Patrol Base (PB) and Observation Points (OP)

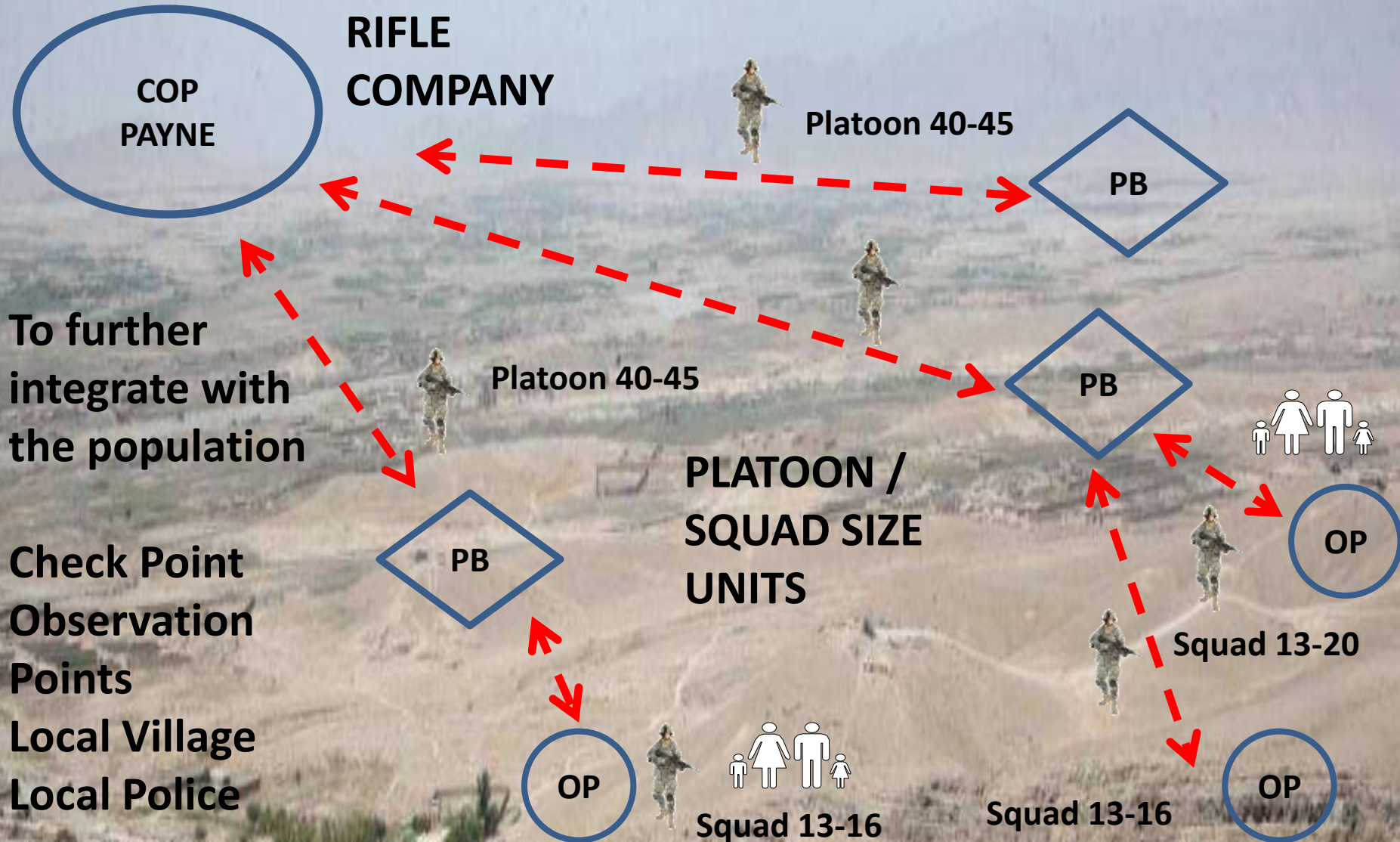

Characteristic's of the PATROL BASE and OBSERVATION POSTS

- No generator support
- No tactical vehicle support
- Dependent on resupply
- Dependent on primary batteries

**Over 100 Patrol Bases
and OP's that
continuously change
locations keeping the
enemy off balance**



Individual Power Requirements

COMM / OPTICS / SENSORS / LASER DESIGNATORS / POSITION LOCATION / PROTECTION



AN / PVS-17
AA Battery



AN / PVS-14
AA Battery



AN / PAS-13D
AA Battery



AN / PEQ-16A
DL-123A Battery



Hand-held flashlight
AA Battery



MIOX Water Purifier
AA Battery



AN / PSC-13 D-DACT
Unique or AA Battery



DAGR
AA Battery



AN / PRC - 148 or 152
Unique Batteries



AN / PRC-153
Unique Battery



Quiet Pro Headset
Unique Battery



Squad Digital Camera
Unique Battery



AN / PRC-117F
BA-5590 / BA-5390 / BB-2590 Batteries



Rugged Laptop
Unique Battery











Challenges associated with PATROL BASE and OBSERVATION POSTS

- Large AO's
- Long duration patrols (8-10 days)
- Critical dependence on radios
- Carry 1-2 days + of supply
chow / ammo / batteries / water
- **BATTERY RESUPPLY EVERY 48 HOURS**
- Re-supply ties patrols to LOCs stalling
operational momentum



Rechargeable Batteries

Even if you choose to use primary batteries you still have to plan to support those radios that only use RECHARGEABLE batteries.



AN/PRC-148

AN/PRC-152

AN/PRC-153

Battery Resupply Every 48 Hours

- Operating AN/PRC-152 radios continuously powered for two days can requires 216 AA or 160 3 Volt batteries per radio













SQUAD

PLATOON

COMPANY
COP

BATTALION
FOB

PATROL BASE / OBSERVATION POST

	PRIMARY BATTERIES		
			GENERATORS (2-3kW)
	RECHARGEABLE BATTERIES		
<p>Renewables can completely power PBs and OPs</p>			BATTERY CHARGERS
		HAND HELD RADIO POWER ADAPTERS	
	SPACES		24V RADIO POWER ADAPTERS
			
			OBVP
Fielded or being fielded		Still in development or next Generation	



HH-RPA for the AN/PRC-152



SOLAR PORTABLE ALTERNATIVE COMMUNICATION ENERGY SYSTEM (SPACES)



The SPACES MSD collects energy from various sources (solar, DC/AC, Vehicle) to recharge BB-2590 batteries and to power external devices (12 and 24 VDC radios).

SOLAR PORTABLE ALTERNATIVE COMMUNICATION ENERGY SYSTEM (SPACES)

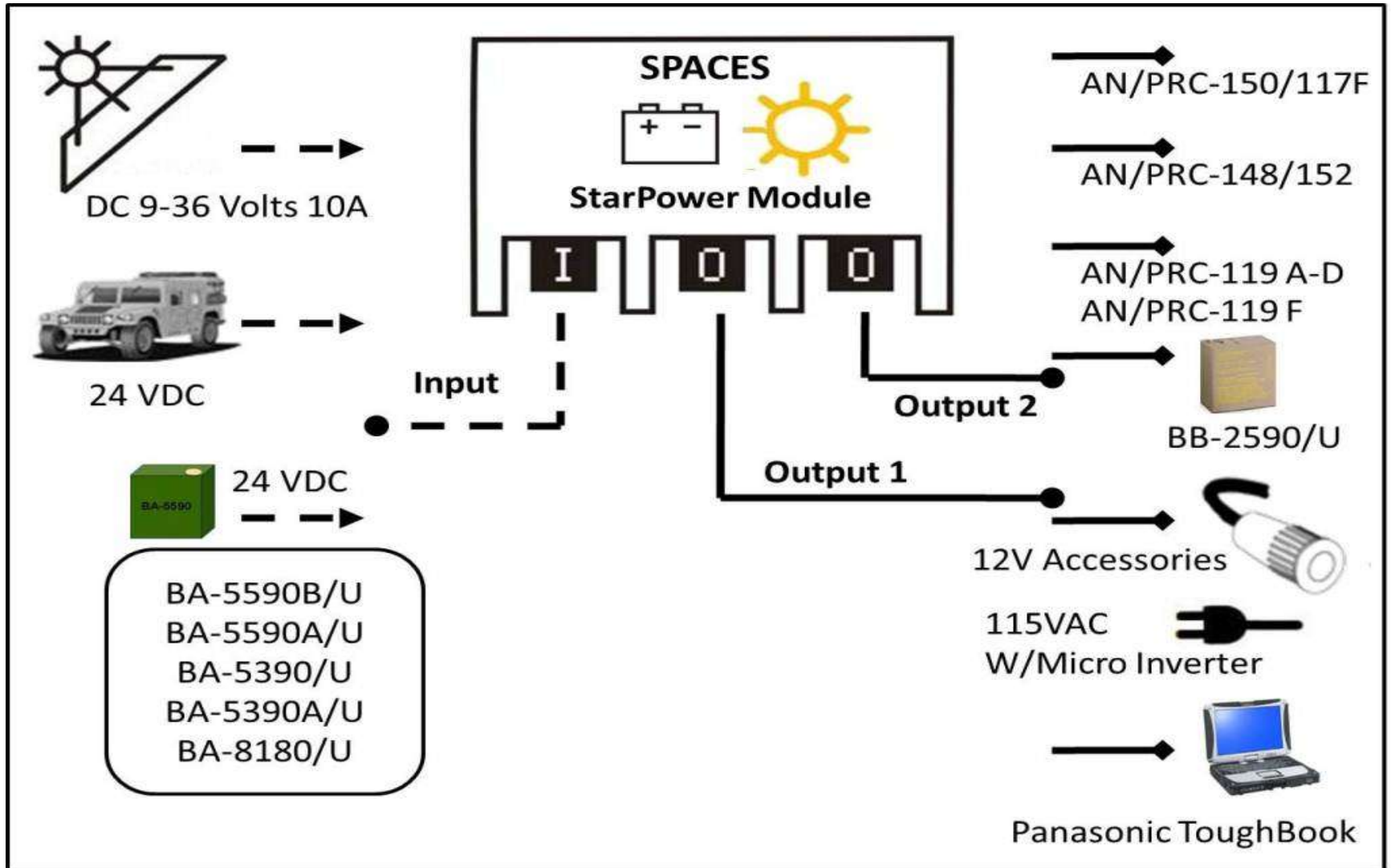

DC to AC
Inverter



Impact of Renewable Systems

3/5 dated January 2011

- 90 Days without the usual daily re-supply of batteries.
- 3 week patrol no batteries (norm every 2 days re-supply).
- Powered two patrol bases with renewable energy only.
- Fuel consumption reduced by 90% at the company level.
- Reduced weight by 700 lbs. and cost by \$40K on one 3 week patrol.

New Requirements and Opportunities

- ❑ Smaller and more capable SPACES (renewable energy) systems (SPACES Generation II pending)
- ❑ Longer lasting primary batteries (new chemistries)
- ❑ GREENS (renewable energy) increased wattage and smaller footprint
- ❑ Small man-portable generators
- ❑ Tactical general purpose UPS

QUESTIONS

