



RDECOM



*Nausheen Al-Shehab, Ernest L. Baker, Adam Enea: US ARMY ARDEC
David Hunter, Larry Pitts, Karen Huddleston,
Cody Anderson: GD-OTS*

Prepared for
NDIA Insensitive Munitions &
Energetic Materials Technology Symposium
May 14-17
Las Vegas, NV



TECHNOLOGY DRIVEN. WARFIGHTER FOCUSED.

TESTING OF AN IM UPGRADED M430A1 40 MM GRENADE

May 2012

DISTRIBUTION STATEMENT A. Approved for public release; distribution is unlimited



- Background
 - Project Approach
 - IM Testing of Baseline Warhead
- IM Design Configuration for Warhead
- IM Engineering Test Results – Overview
 - Bare Warhead Slow Cook-off (SCO)
 - Warhead Venting feature in simulated Packaged SCO
- Warhead Venting - Hot Gun Launch
- Warhead Venting Down-Selection Testing – FCO Results
- Conclusions



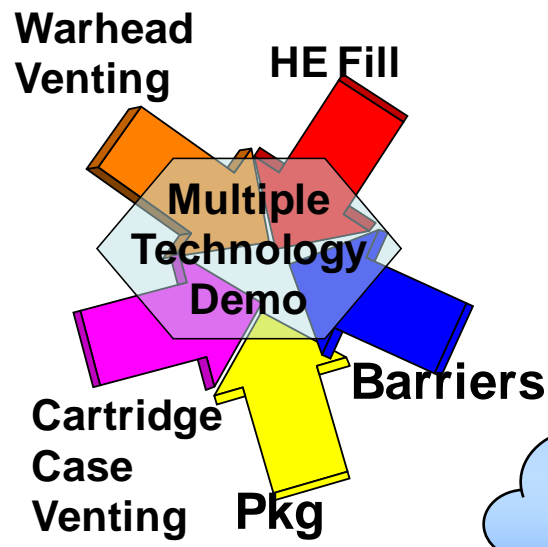
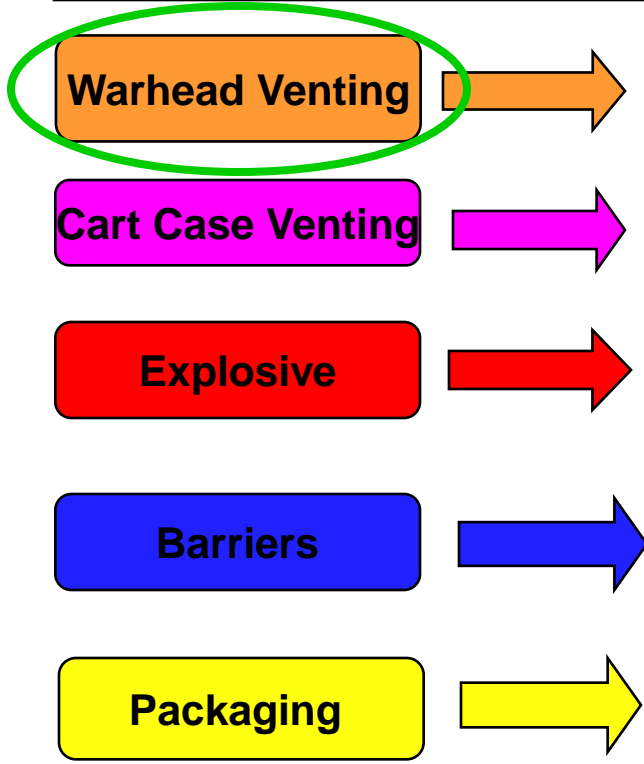

Integrated System Solution

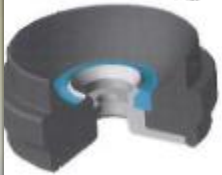
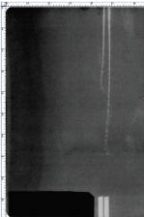
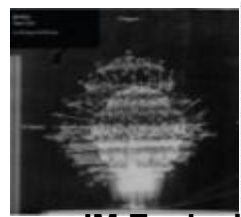
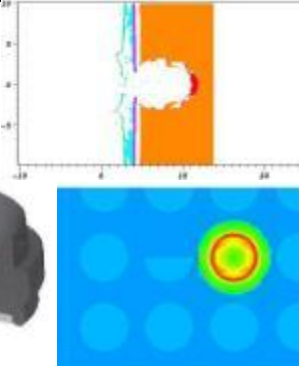
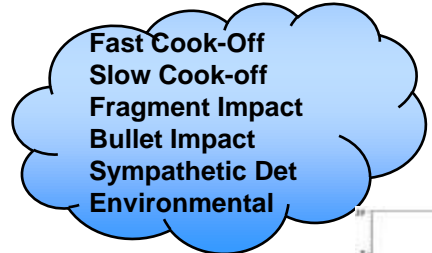

Packaging Venting

Warhead Venting

IM Explosives

Cartridge Venting

Barrier Modeling

When subjected to fast and slow cook-off tests as defined in MIL-STD-2105C the currently fielded 40mm M430A1 HEDP Grenade reacts violently.

Baseline IM Response						
Tier II Munitions	FCO	SCO	BI	FI	SR	SCJ
40mm HEDP - M430A1	III	I	V	I	F	F

Bare Warhead Engineering SCO Tests

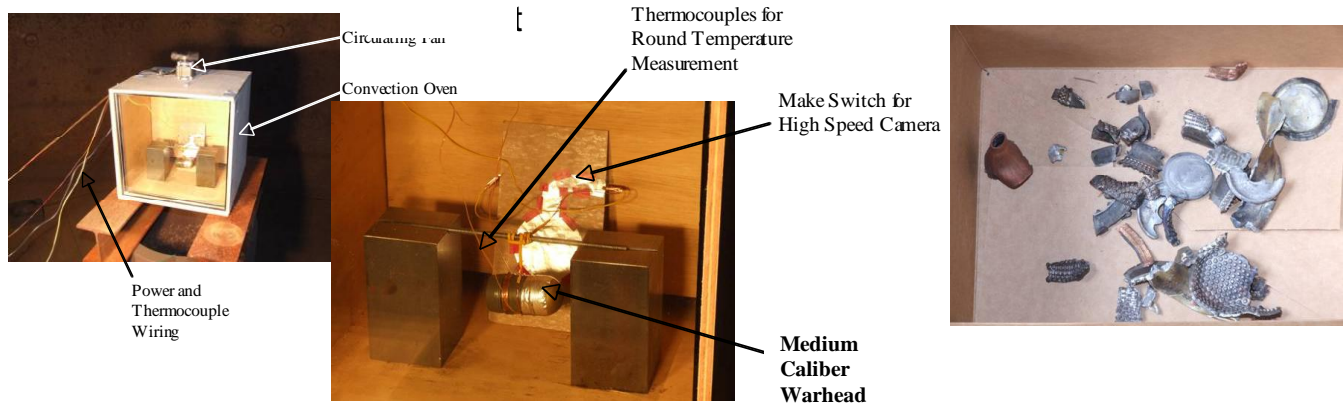

Type II

Project Objective:

Demonstrate Type V (Burning) Reaction when Integrated into 40mm M430A1 HEDP System

Demonstrate IM venting solution for High G gun-launched “smaller” ammunition

- IM vent design for M430A1 Grenade uses a Melt Ring to Pass FCO and SCO without Performance Reductions
- Various Melt Ring Materials Possess Suitable Strength and Thermal Properties. Plastic Selected for Demonstration
- Functions as Structural Load Bearing Component during Gun Launch, Set Back, Set Forward, and Spin.
- Melt Ring Releases Fuze and SC Liner Allowing HE Fill to Vent Safely Resulting in Type V (Burning) Reaction when Subjected to Elevated Temperatures that would Normally Cause Detonation

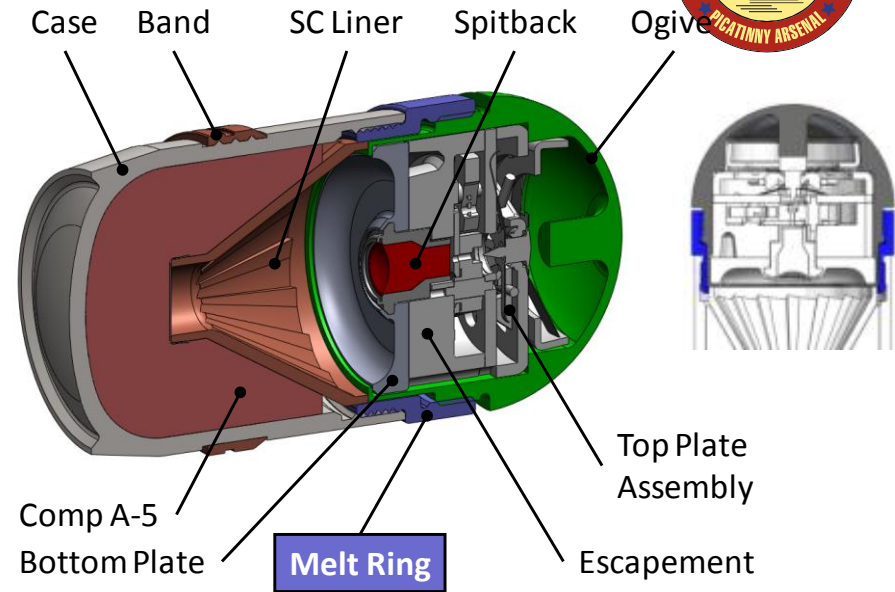

Confined

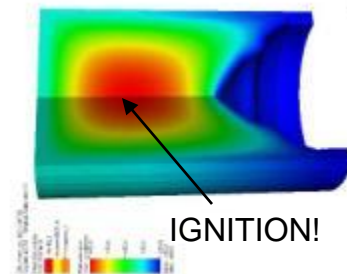

Unconfined

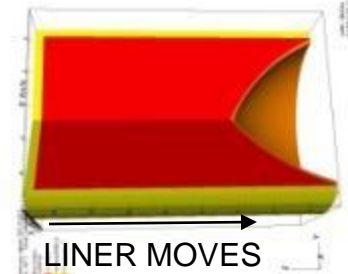

- Successful 6 SCO tests (bare projectiles) at 6F/h resulted in Type V (All Melt Ring Materials)
- Successful SCO test (simulated packaging) at 6F/h resulted in Type V (Material 1)
- Successful ambient gun launch soft-recovery tests (All Melt Ring Materials)
 - Items fired from MK-19, single shots at ambient temperature
- All melt ring materials survived hot gun launch tests – Soft recovery
- 4 FCO tests of bare projectiles
 - 2-each Material 1 melt rings – Type V
 - 2-each Material 2 melt rings – Type IV

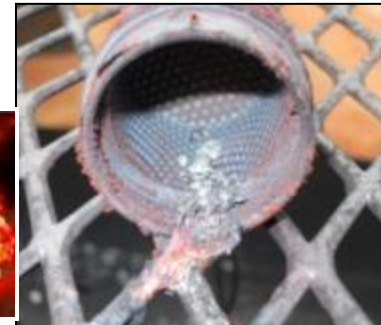

- 6 SCO Tests of three different melt connector ring materials

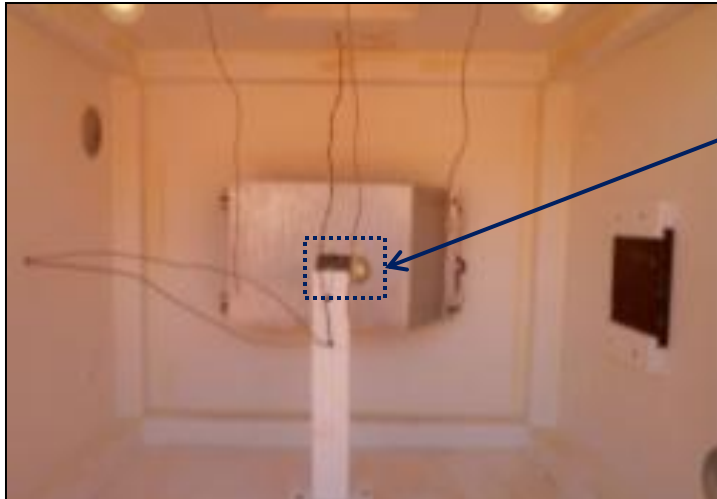

Warhead Venting Simulated Packaged SCO

- Packaged SCO Tests of IM Upgraded M430A1 with Material 1 Melt Ring –
 - *Type V Reaction (Live warheads + Inert cartridge cases)*

Material 1 Melt Ring

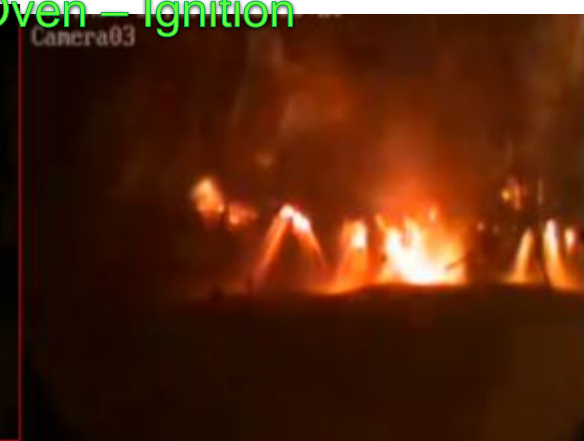

- 10 Gun Tests of IM Upgraded M430A1 conditioned to 160F
 - Items fired from MK-19, single shots at ambient temperature
 - Five (5) tests with Material 1 Melt Ring – All survived gun launch
 - Five (5) tests with Material 2 Melt Ring – All survived gun launch

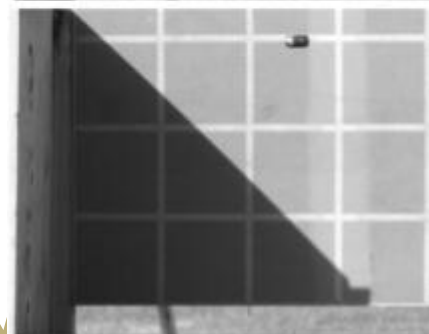
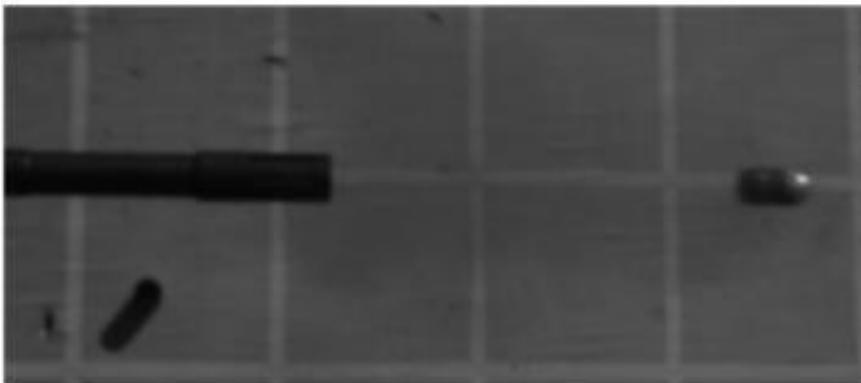
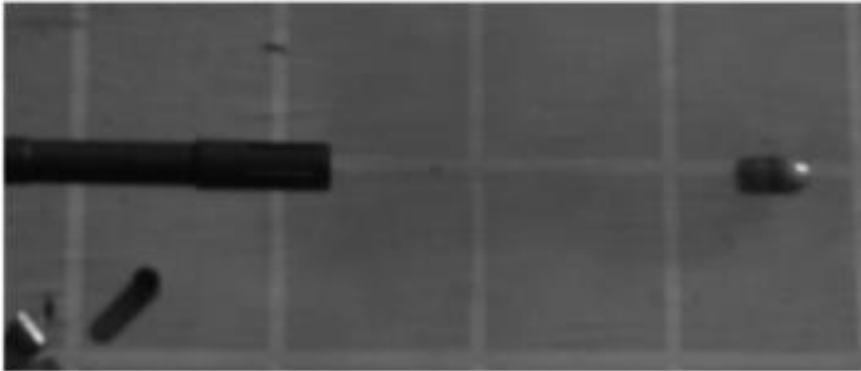

Warhead Venting Down-Selection Testing – FCO

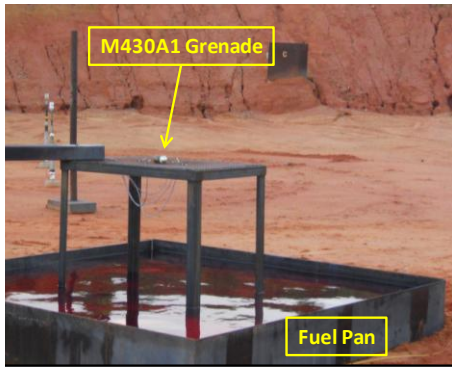

FCO Test Set-Up

Material 1 Melt Ring
2 tests - **Type V**



Material 2 Melt Ring 2 tests – **Type IV**

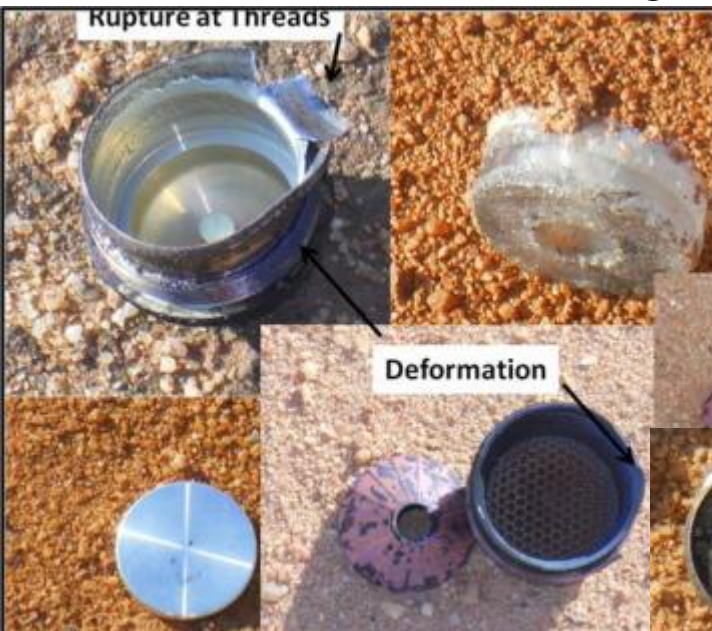

- Previously demonstrated methods for venting and depressurizing of explosive billets would fail structurally during set-back and set-forward loads produced while launching medium and high velocity munitions.
- This specialized venting design developed for the M430 allows for removal of the confinement and allows for depressurization of the explosive billet.
- The novel material and thread geometry ensures that the projectile will survive the higher acceleration loads while still mitigating violent response to fast and slow cook-off conditions.
 - The melt ring geometry ensures that during setback loading, the load path from the fuze pushing into the body is not supported by the melt ring, significantly reducing the peak stresses within the plastic.
 - During set forward, the thread design and selection of material ensures the fuze is fully supported.
- Venting technology is a practical means of relieving pressures within the warhead to mitigate SCO and FCO threats. Relatively low cost of implementing liner release design, high pay-off for mitigation of cook-off threats

- **Limited Fuze Environmental Testing**
- **Rapid Fire and Single shot Testing (Live)**
- **Creep Testing of Material 1 under operational temperature extremes**
- **Compatibility Testing (Comp A5 + Loctite + Material 1 + Metal parts)**
- **Limited Environmental Testing (Packaged)**
- **Provide hardware for Multiple Technology IM Testing**



- ✓ PEO Ammo
- ✓ PM-MAS
- ✓ RDAR-MEM-J (40mm Grenade Ammunition Special Projects Team)
- ✓ GD-OTS
- ✓ AO Milan
- ✓ DSE
- ✓ RTC (Redstone Technical Center)
- ✓ NTS