

Comparison between IM fragment and EFP impact

Gert Scholtes, Peter Hooijmeijer and Ries Verbeek, TNO Netherlands

Gert.Scholtes@tno.nl tel: +31 (0)6 2280 1250 www.tno.nl/ammunitionsafety

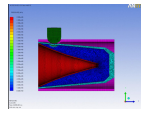



Overview

- Introduction
- Literature on EFP's
- Fragment impact Experiment
- Model/ FI Simulation
- EFP simulation results
- First comparison
- Worst case scenario
- Summary



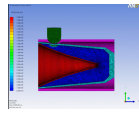

Overview

- Introduction
- Literature on EFP's
- Fragment impact Experiment
- Model/ FI Simulation
- EFP simulation results
- First comparison
- Worst case scenario
- Summary



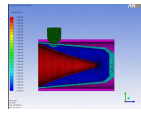

Introduction

- One of the most common threats in the military Out of Area Operations is the IED-EFP
- Direct danger to the personnel
- Hit in a vehicle's munition bunker → catastrophic event with many casualties
- The development of IM munitions is already a major step towards increased munition safety
- Question at “IM technology workshop” held at “Instituut Defensie Leergangen”, The Hague, The Netherlands in June 2011: Is IED-EFP a bigger/different threat than the IM fragment (STANAG 4496) ??



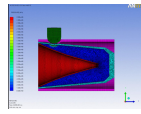

Overview

- Introduction
- Literature on EFP's
- Fragment impact Experiment
- Model/ FI Simulation
- EFP simulation results
- First comparison
- Worst case scenario
- Summary



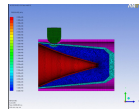

Literature on EFP (C. Weickert and P. Gallagher; K. Weimann)

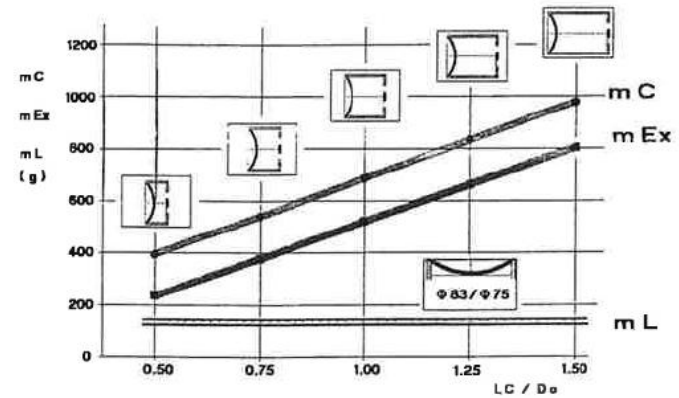
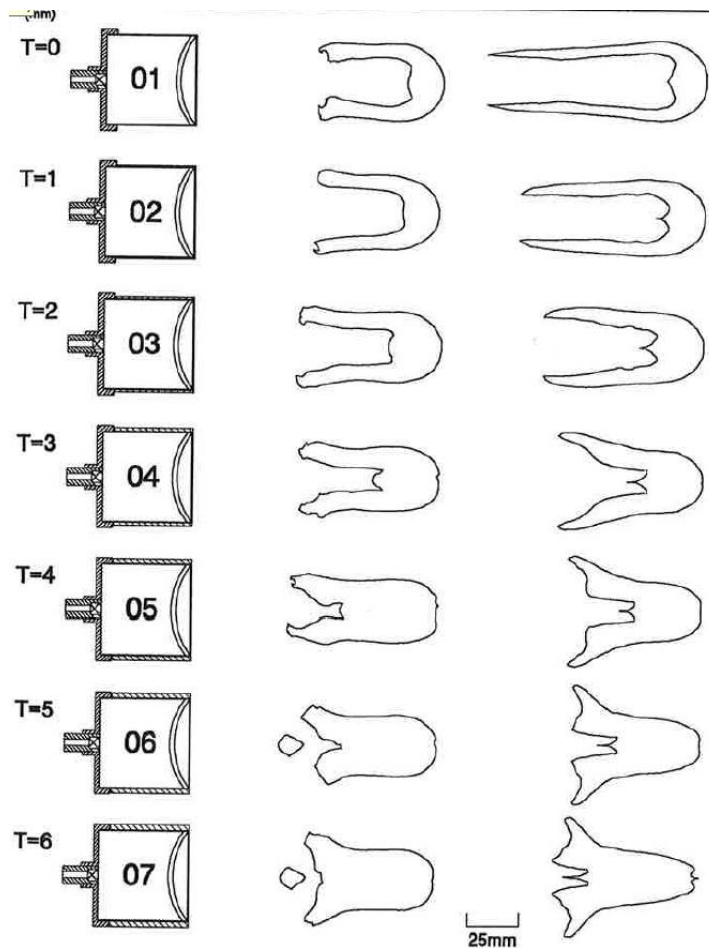

Figure 2. Mass of casing (m_C) and explosive (m_{Ex}) as function of charge length (LC).

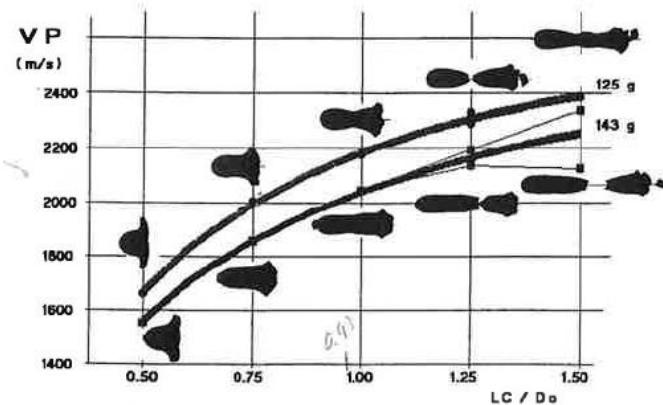
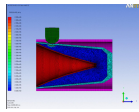
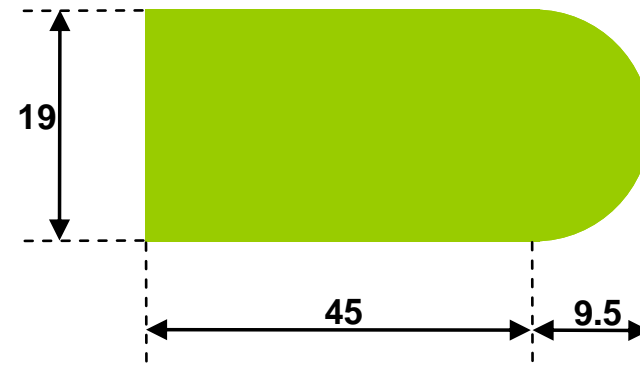
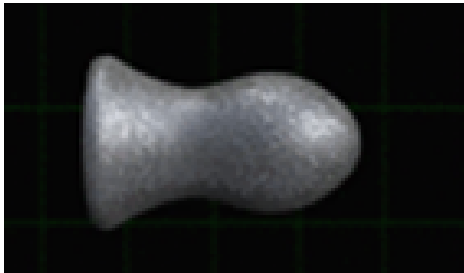

Figure 3. Projectile velocity (VP) and projectile form at different charge lengths (LC).



Arbitrary chosen EFP; 2 types, velocity of 2100 m/s

Type A: $m = 130$ grams, copper



Type B: $m = 133$ grams, copper

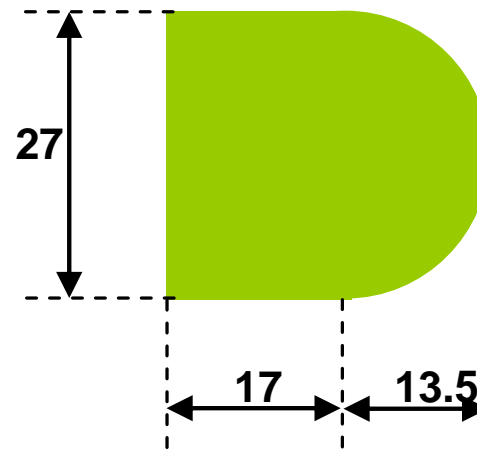

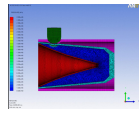

Overview

- Introduction
- Literature on EFP's
- **Fragment impact Experiment**
- Model/ FI Simulation
- EFP simulation results
- First comparison
- Worst case scenario
- Summary



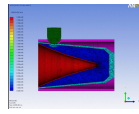

Fragment impact experiment

- › STANAG IM test Fragment: cylinder of 14.3 mm diameter, 15.6 mm long and 18.6 grams at velocity of 2530 +/- 90 m/s
- › Munition: 100 mm/ 90mm warhead Shaped charge with composite casing, High solid loading HMX based explosive
- › Aluminium casing of warhead and copper liner

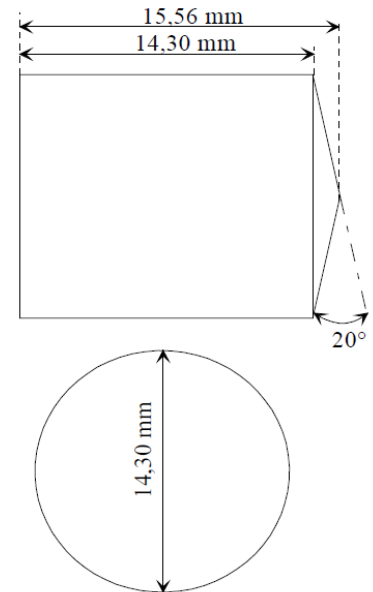

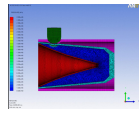

TNO IM Fragment impact 50 mm gun (STANAG 4496)



**At velocity of 2700 m/s
deceleration of ~17 m/s
per meter (7m distance
to target → ~ 120 m/s)**



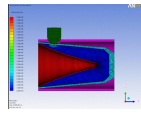

High speed recording bullet vs fragment impact



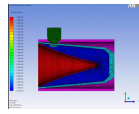

Fragment impact experiment

- Test 1: velocity 2505 m/s, off-centre hit → burning of SC



- Fragment impact 2 at ~2560 m/s: in centre → detonation

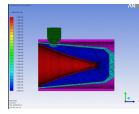

Overview

- Introduction
- Literature on EFP's
- Fragment impact Experiment
- **Model/ FI Simulation**
- EFP simulation results
- First comparison
- Worst case scenario
- Summary



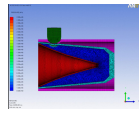

Grid and materials in Ansys-Autodyn

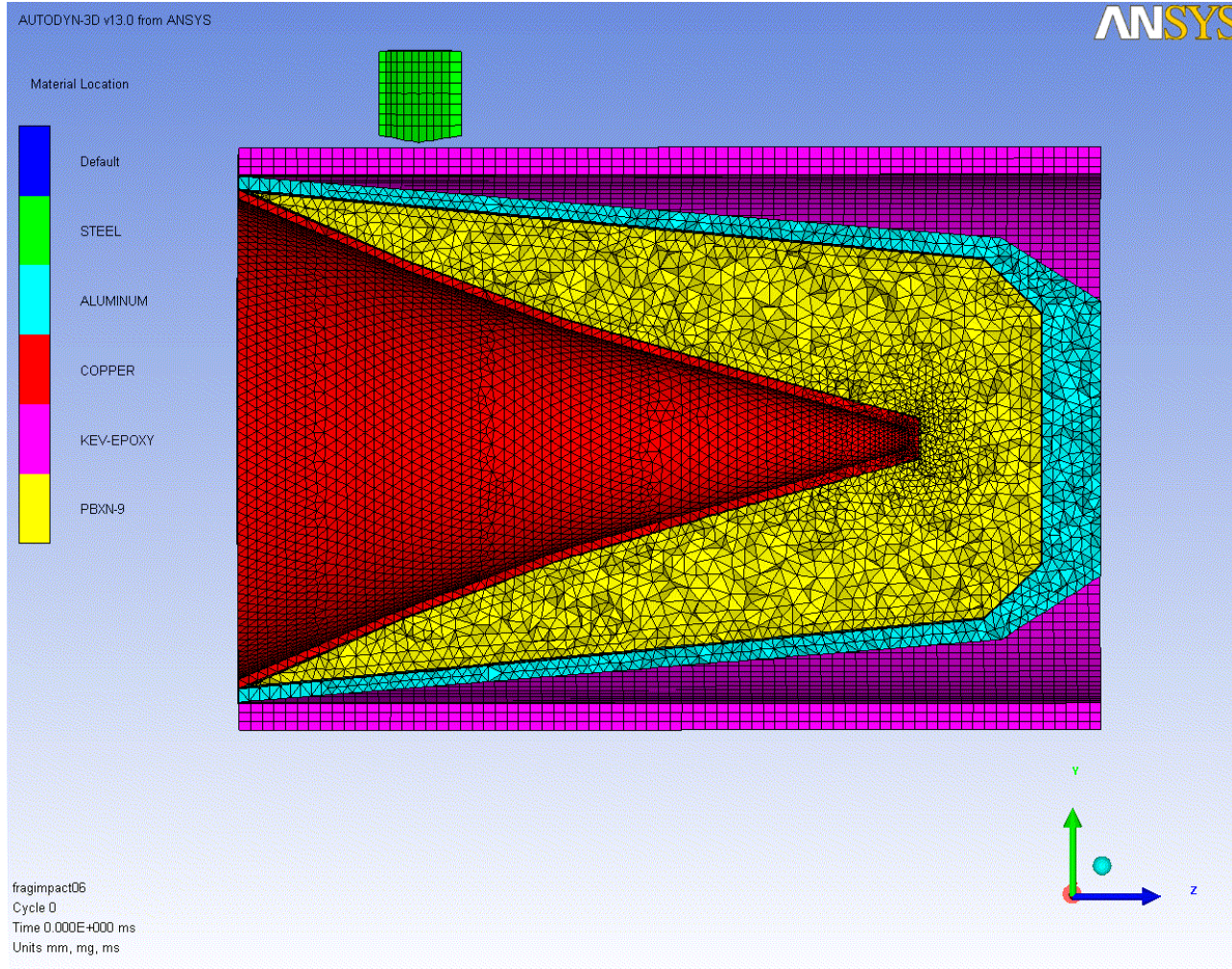

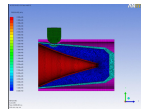

Simulation of fragment impact (center)

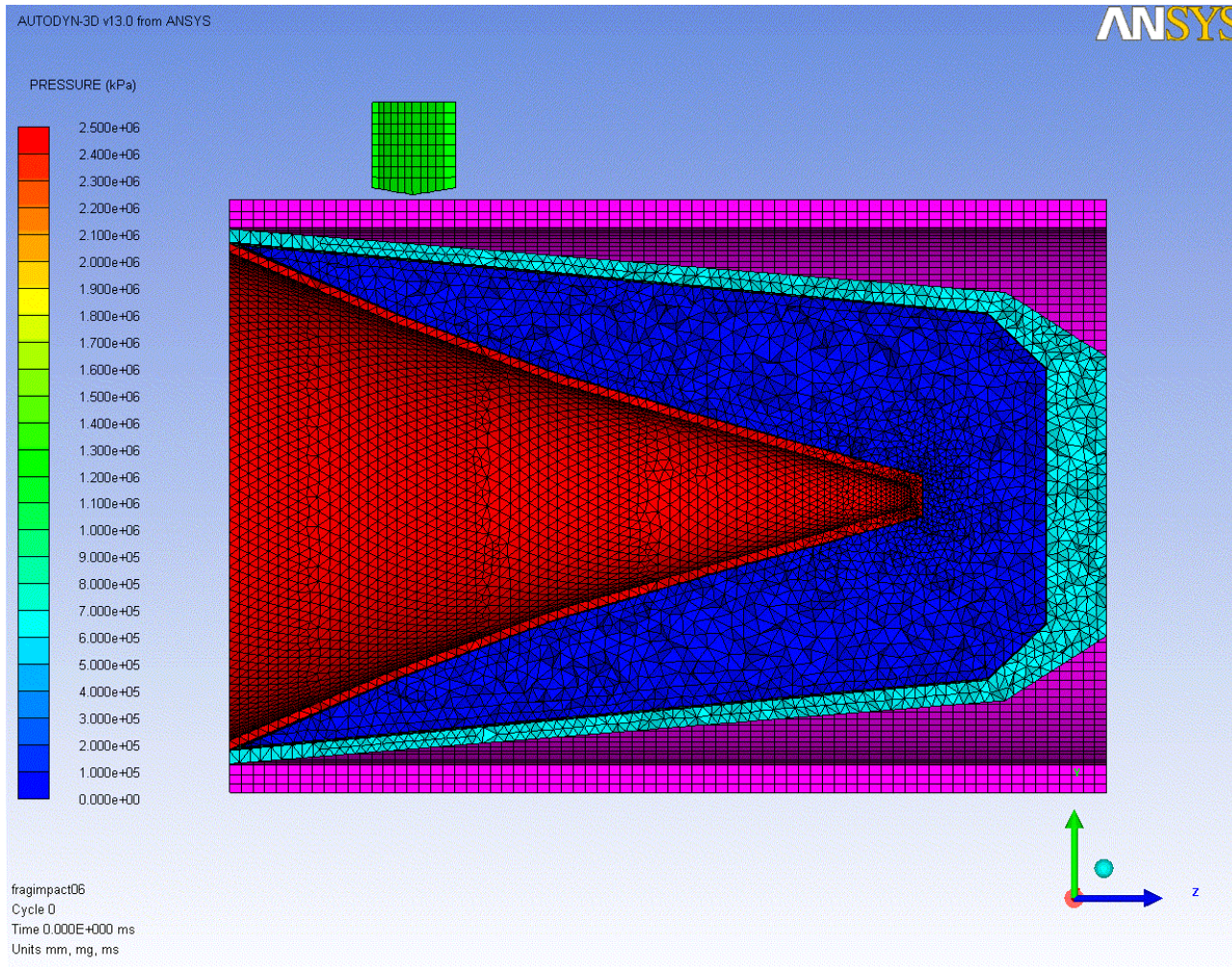

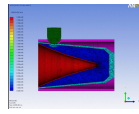

After penetration of fragment (no reaction of explosive simulated)

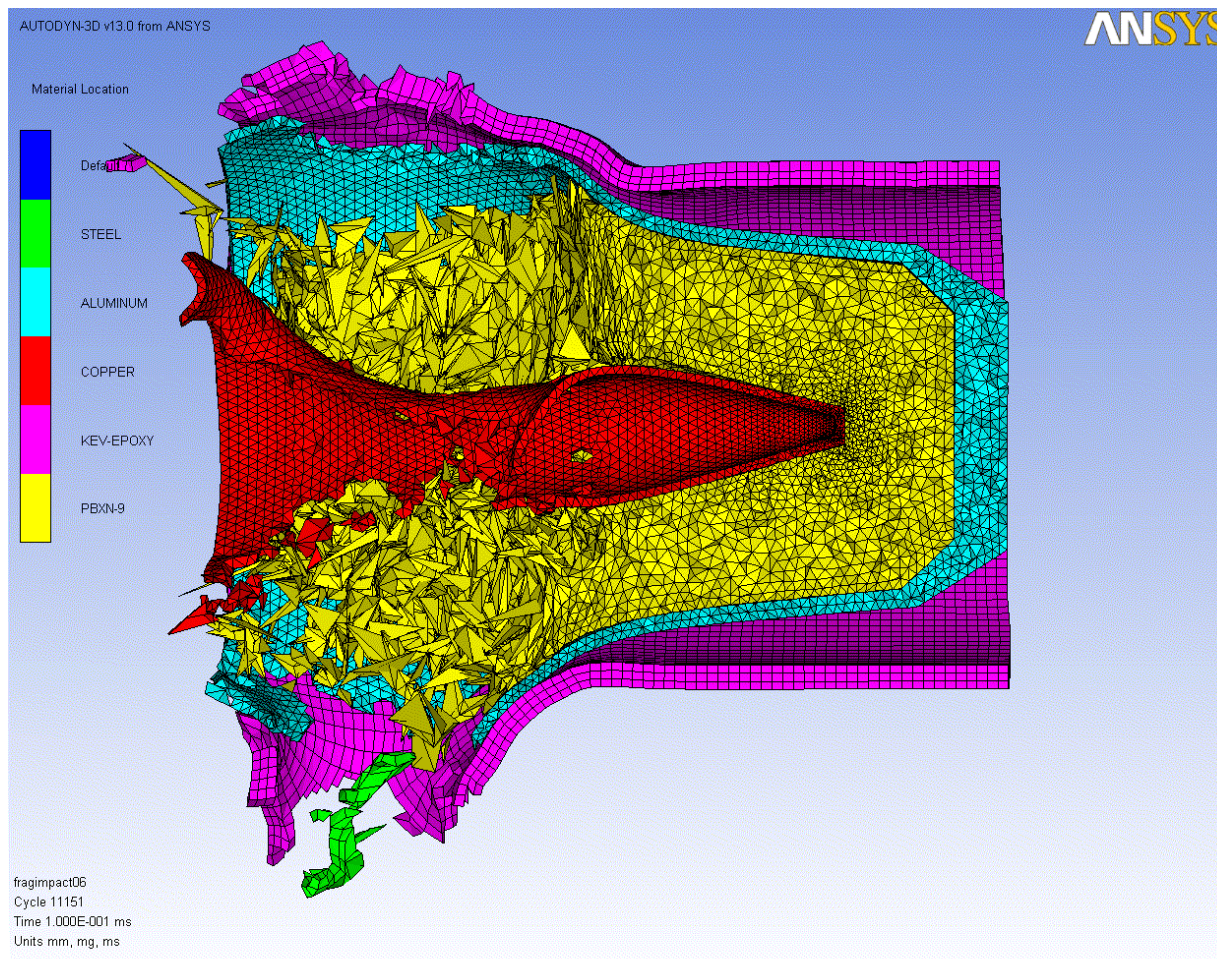

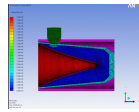

Velocity and pressures; speed drop of 1000 m/s

Part Summary (Ident 0 - fragimpact06)

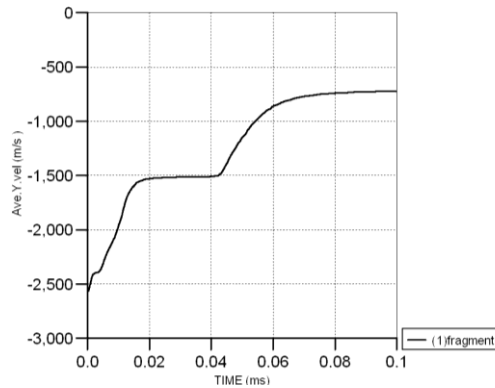

ys

Gauge History (Ident 0 - fragimpact06)

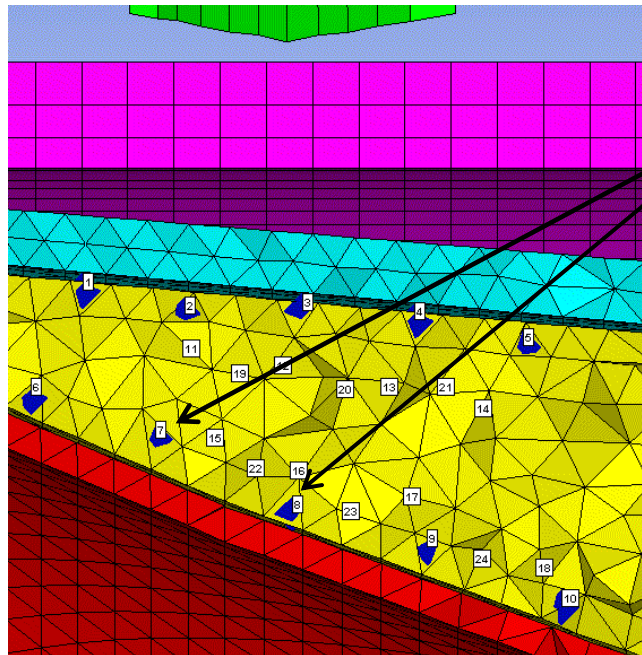
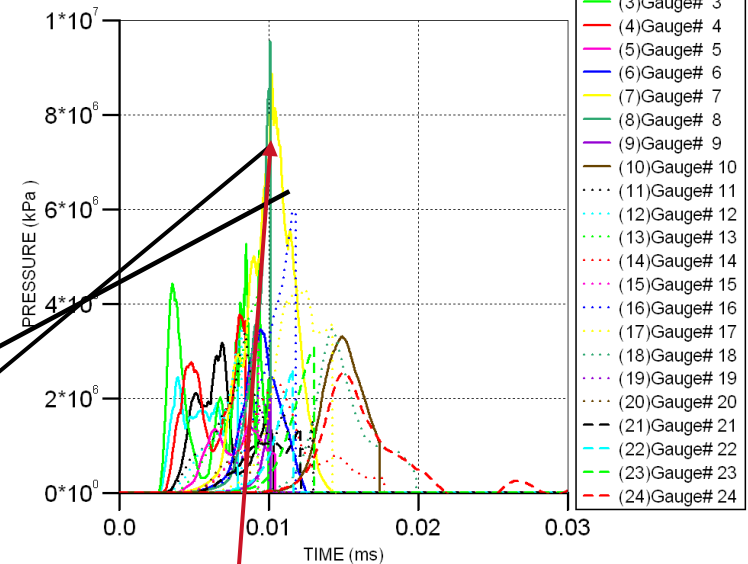

**Reflection of copper
liner → P increase**

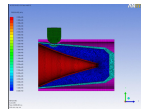

Fragment impact (off-center impact)

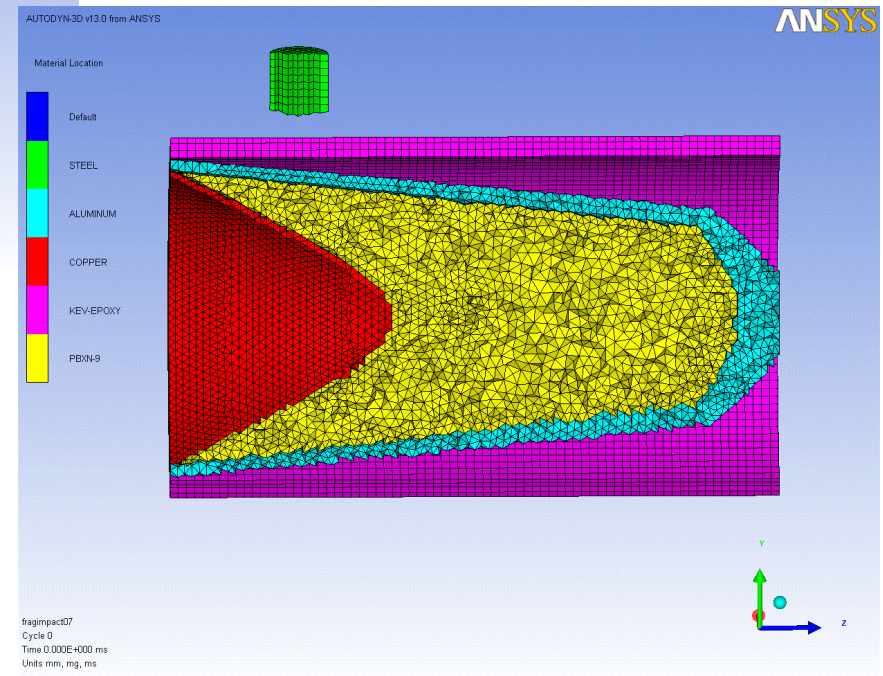
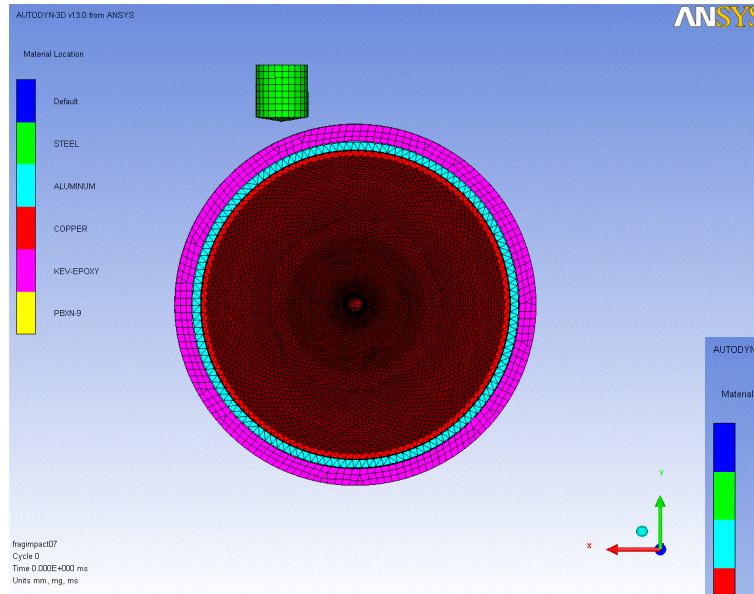

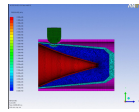

AUTODYN-3D v13.0 from ANSYS

PRESSURE (kPa)

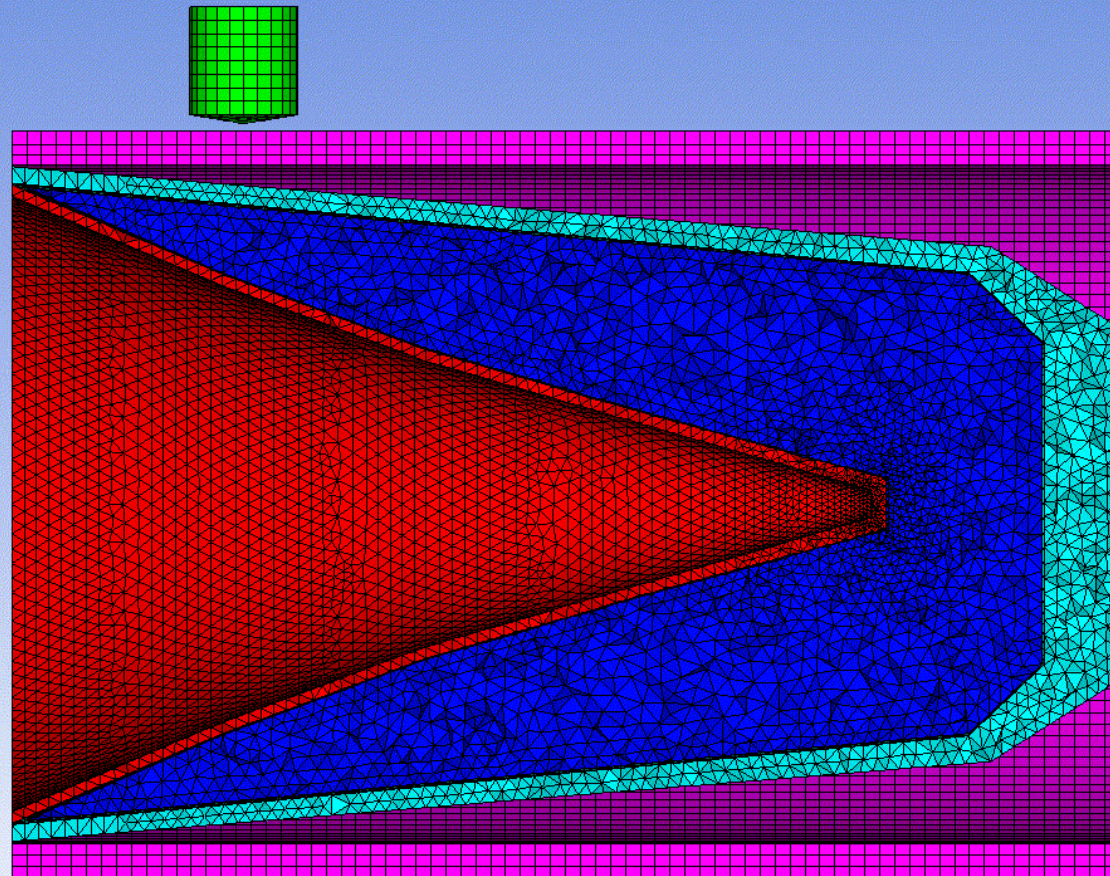
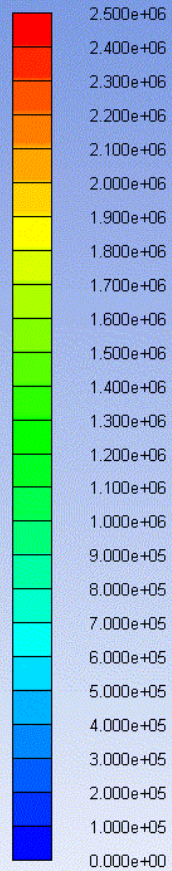

fragimpact07
Cycle 0
Time 0.000E+000 ms
Units mm, mg, ms

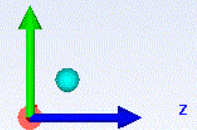

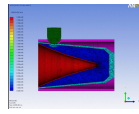

Simulation of off-center impact

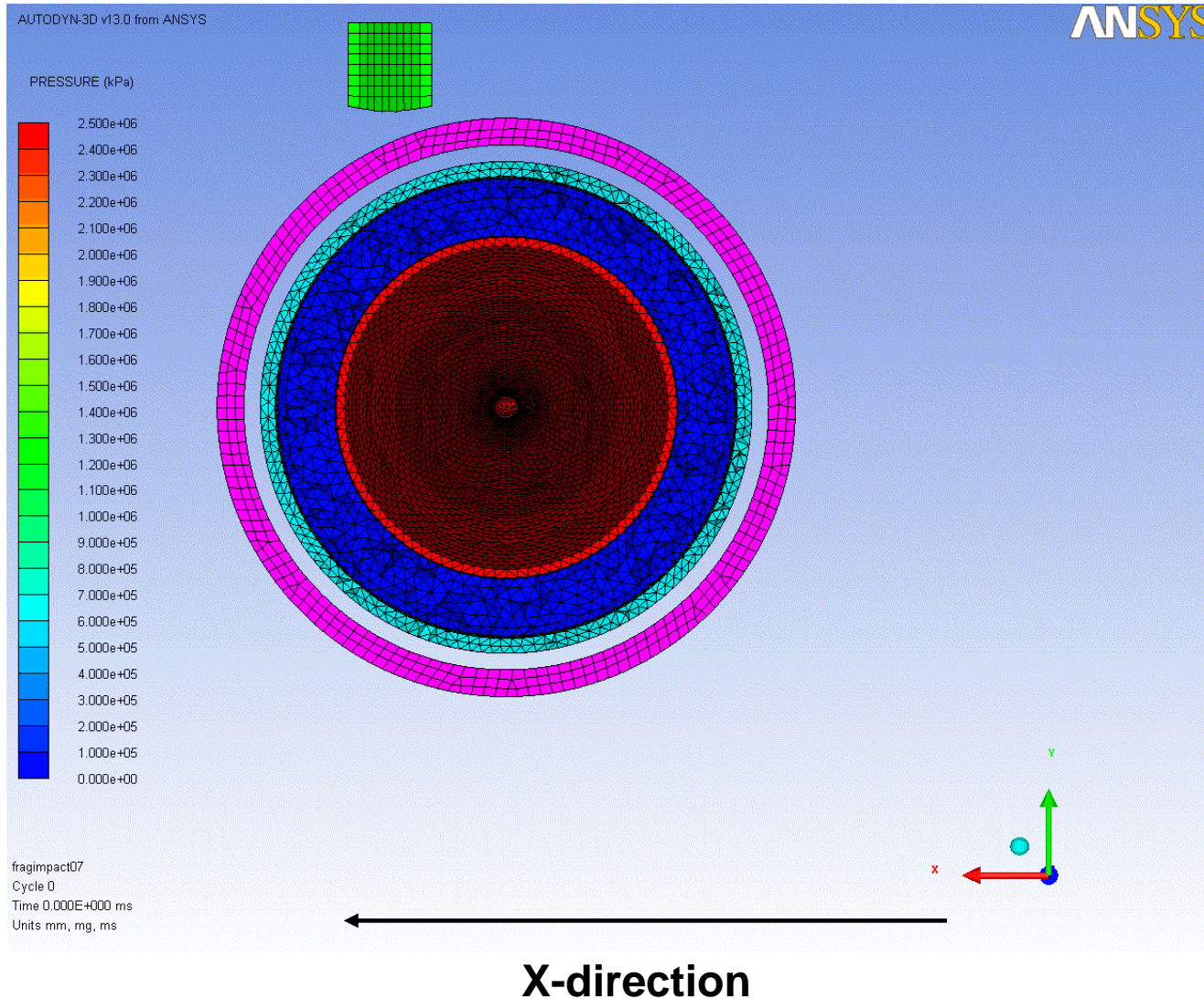

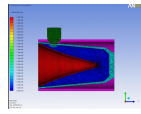

X velocity, displacement of projectile

Part Summary (Ident 0 - fragimpact07)

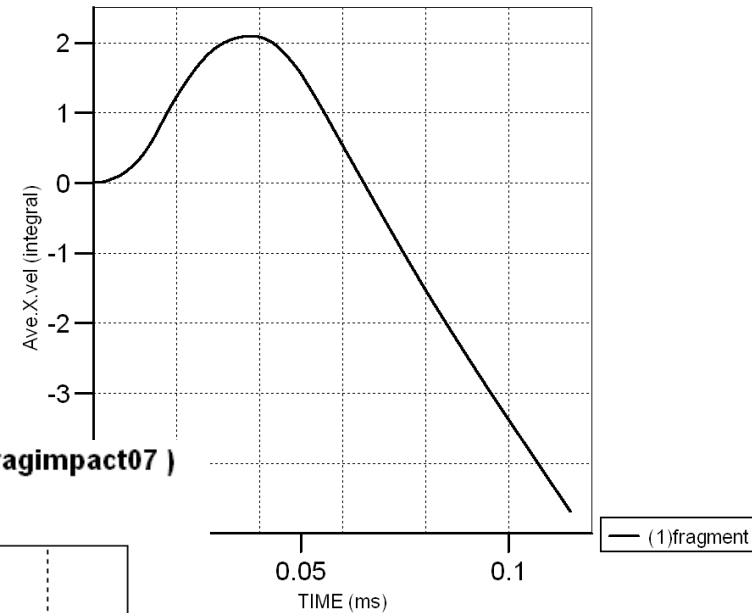
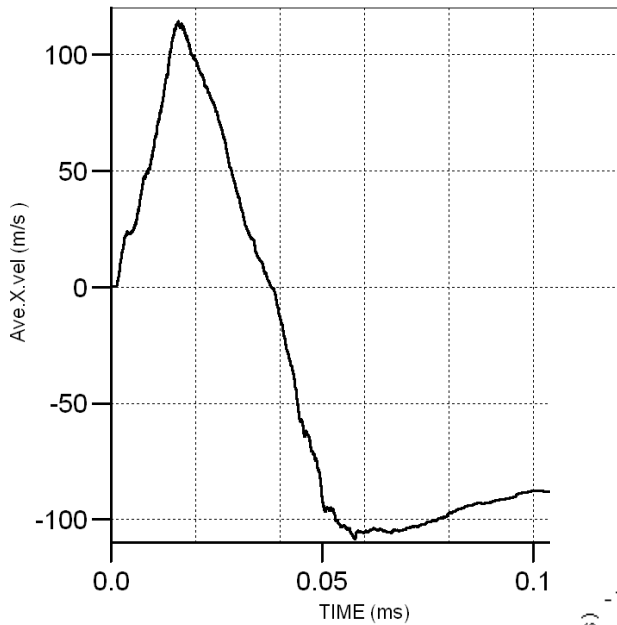

Part Summary (Ident 0 - fragimpact07)

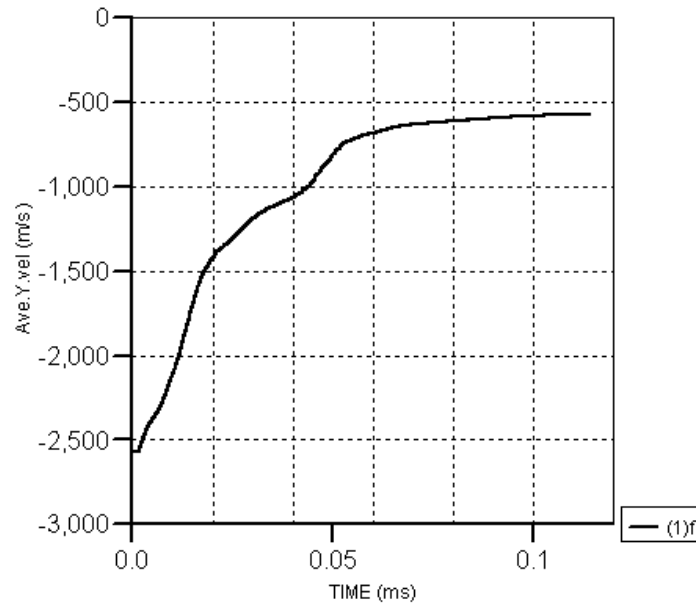

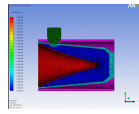

Pressure (off-center)

AUTODYN-3D v13.0 from ANSYS

Gauge History (Ident 0 - fragimpact07)

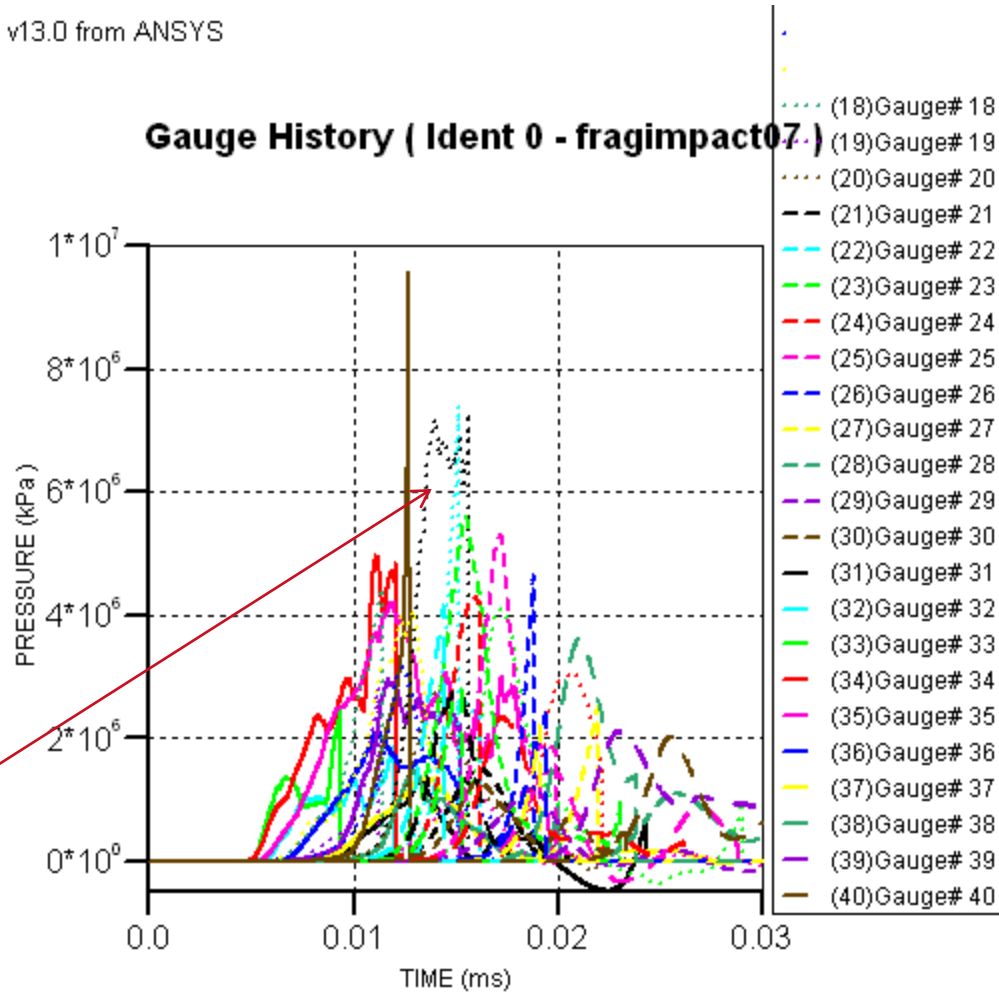

After reflection
of copper liner

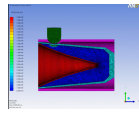

Summary Fragment impact

- Very high pressures with long duration
 - Central impact: 0.8 μ sec at 8 GPa and 3.7 μ sec at 5 GPa; some over 8 GPa
 - Off Central impact: 1.2 μ sec at 6.5GPa

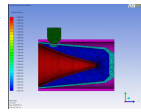

Overview

- Introduction
- Literature on EFP's
- Fragment impact Experiment
- Model/ FI Simulation
- **EFP simulation results**
- First comparison
- Worst case scenario
- Summary



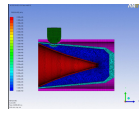

Impact of 19 mm EFP (2100 m/s)

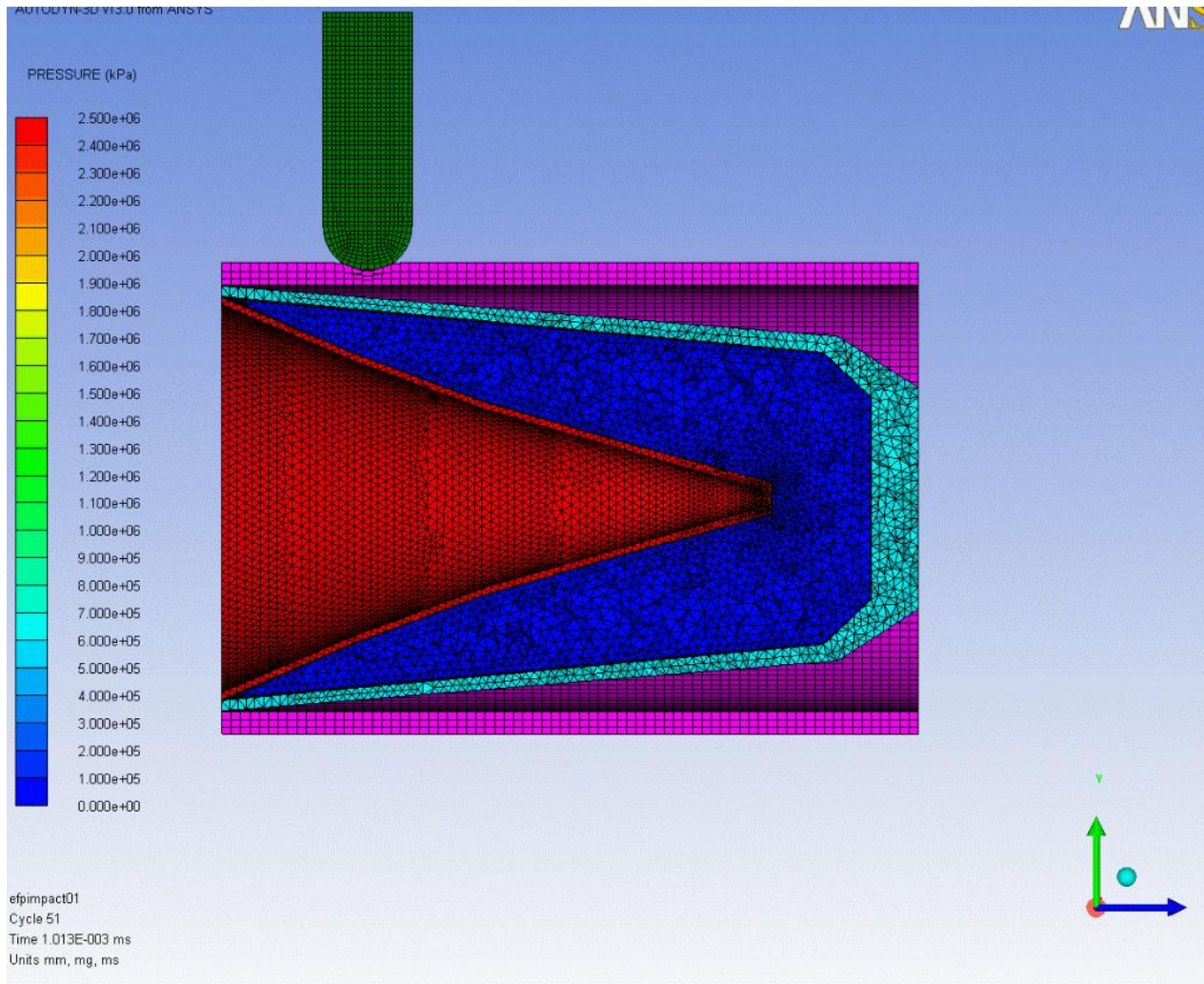

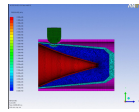

AUTODYN-3D v13.0 from ANSYS

PRESSURE (kPa)

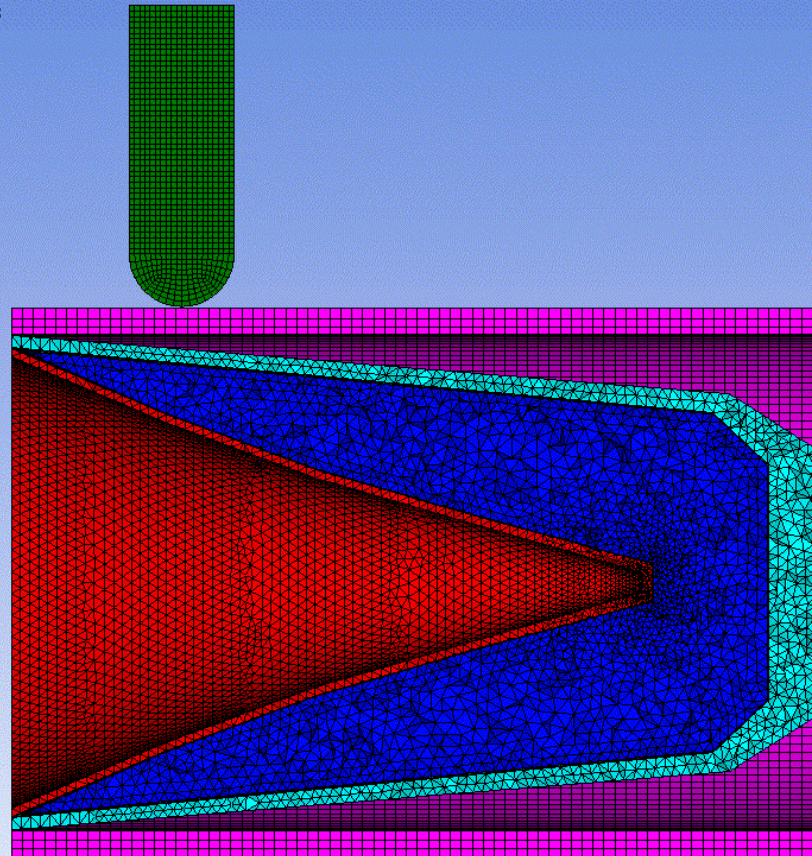
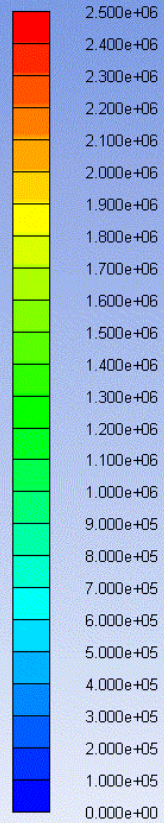

efpimpact01
Cycle 0
Time 0.000E+000 ms
Units mm, mg, ms

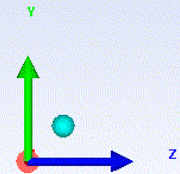

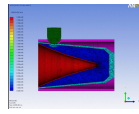

EFP velocity decrease (19 mm) ~200 m/s

AUTODYN-3D v13.0 from ANSYS

Part Summary (Ident 0 - efpimpact01)

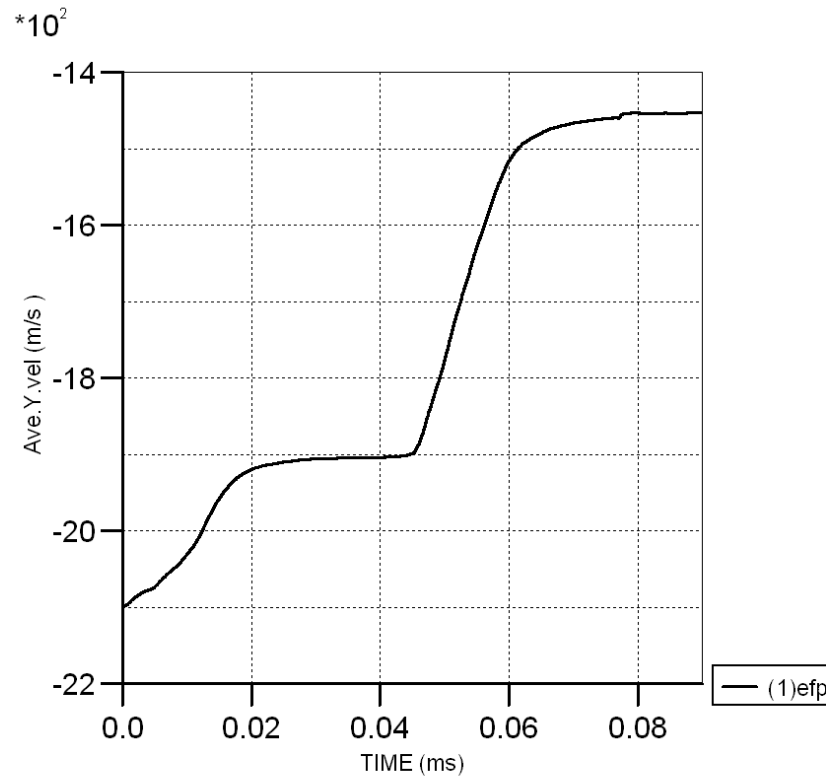

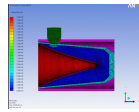

Shock pressure (19 mm)

ANSYS

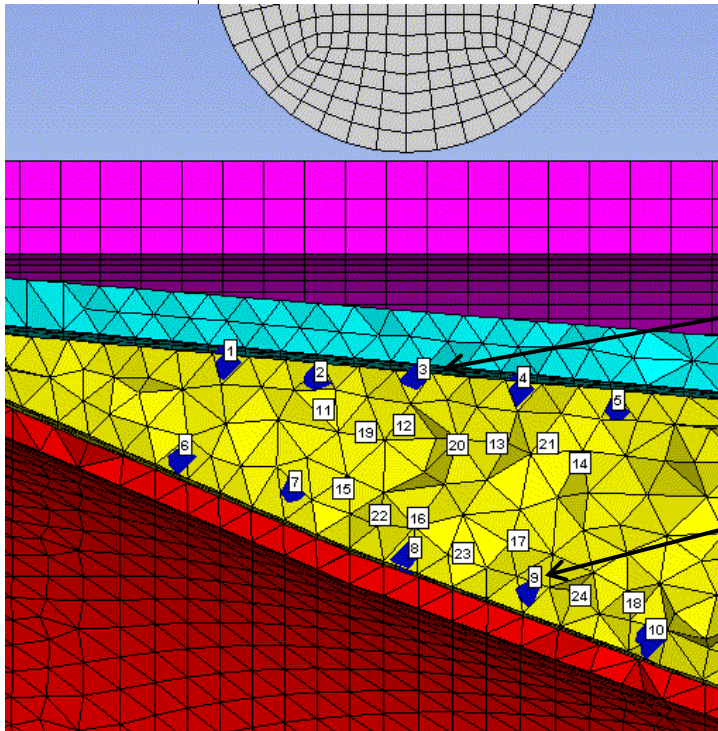

Gauge History (Ident 0 - efpimpact01)

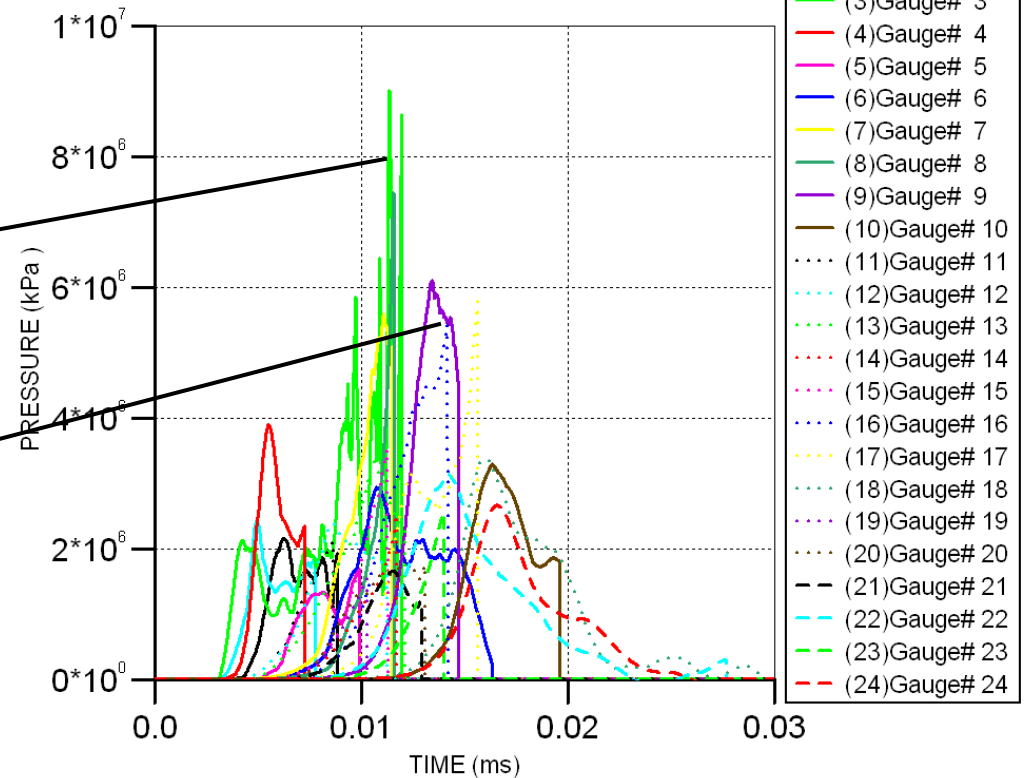

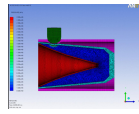

27 mm EFP impact

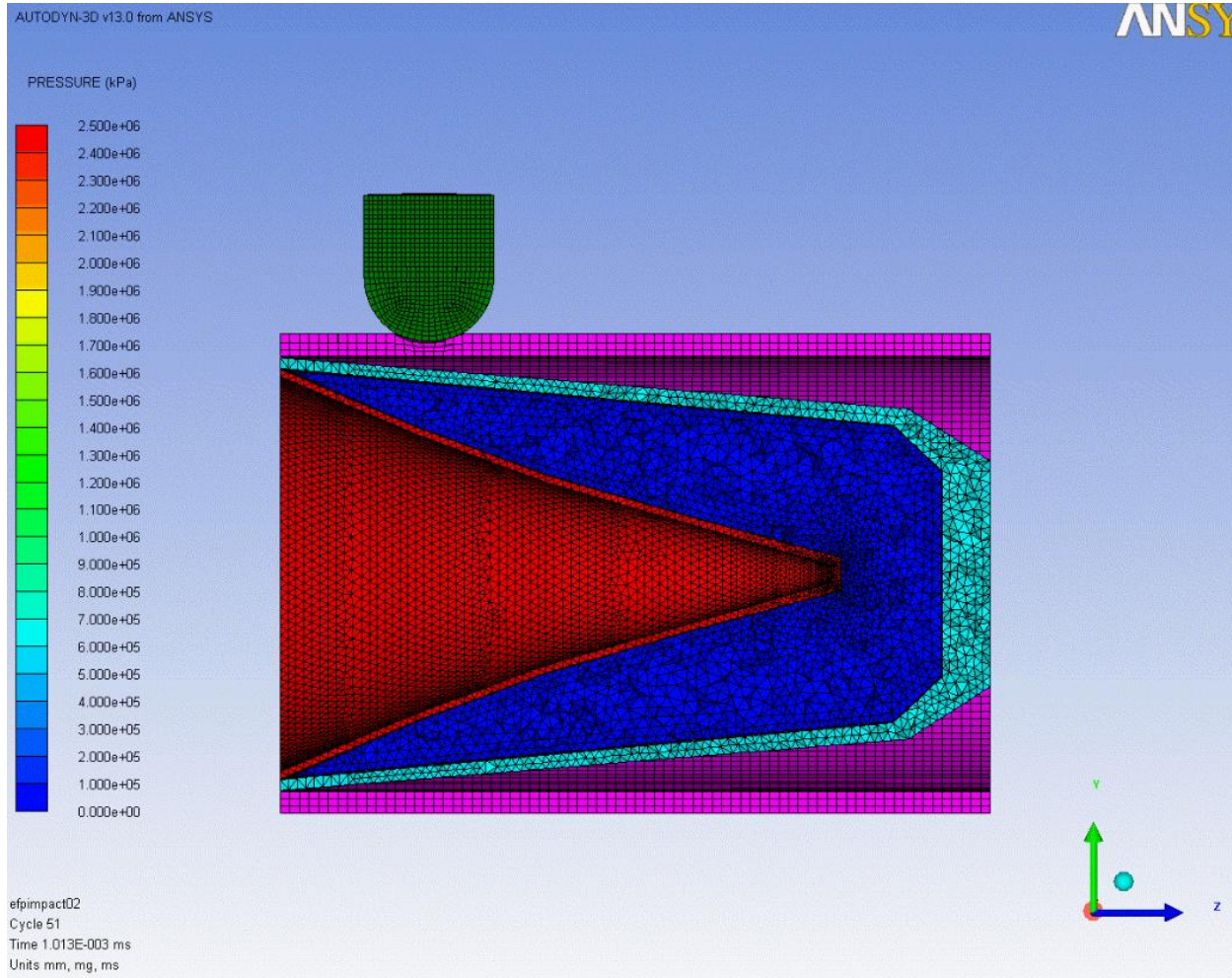

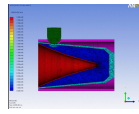

Simulation of 27 mm EFP at 2100 m/s

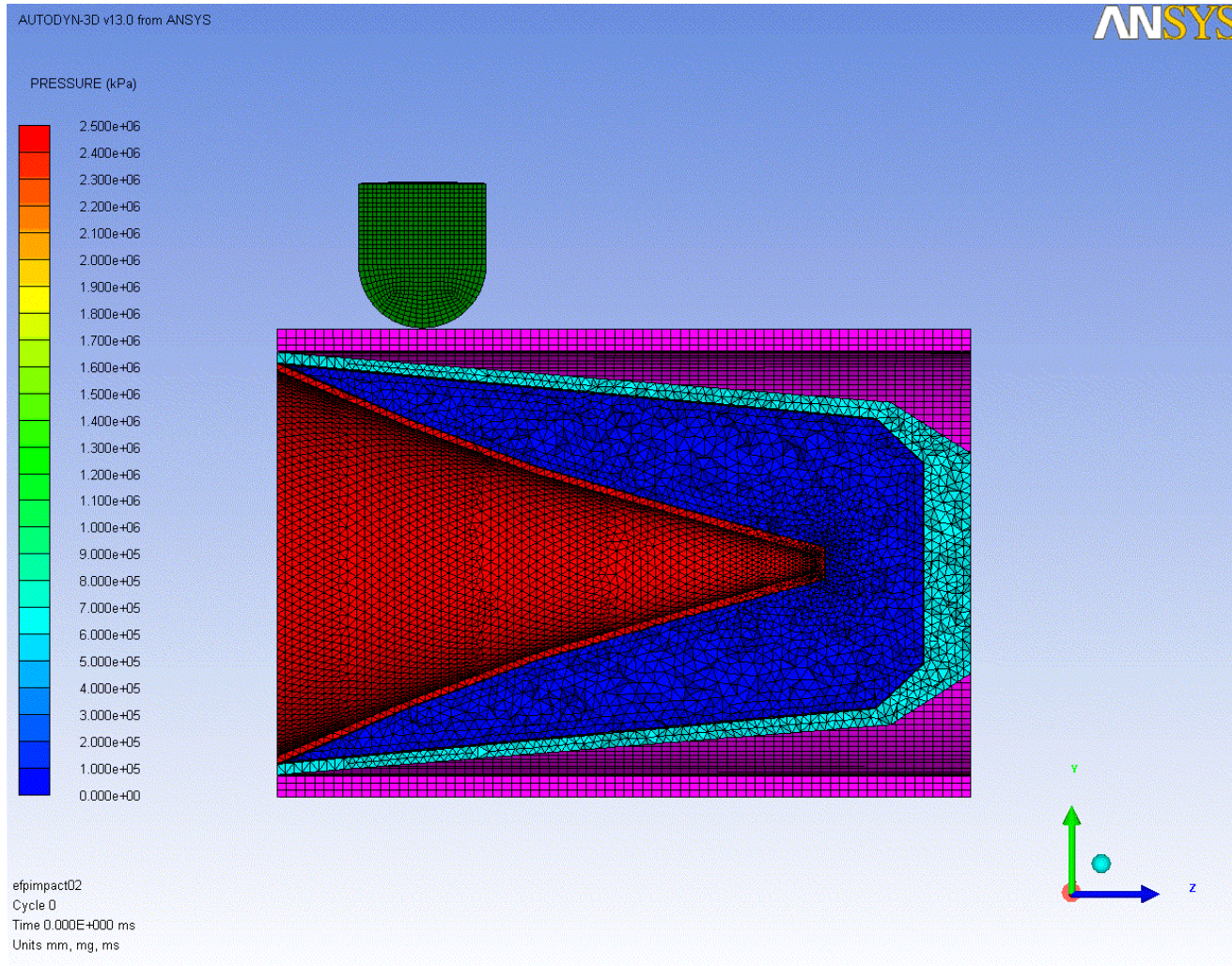

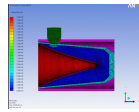

Velocity decrease of EFP (27 mm) ~ 350 m/s

Effect. surface 5.7 cm² (twice the value of 19 mm EFP = 2.8 cm²)

Part Summary (Ident 0 - efpimpact02)

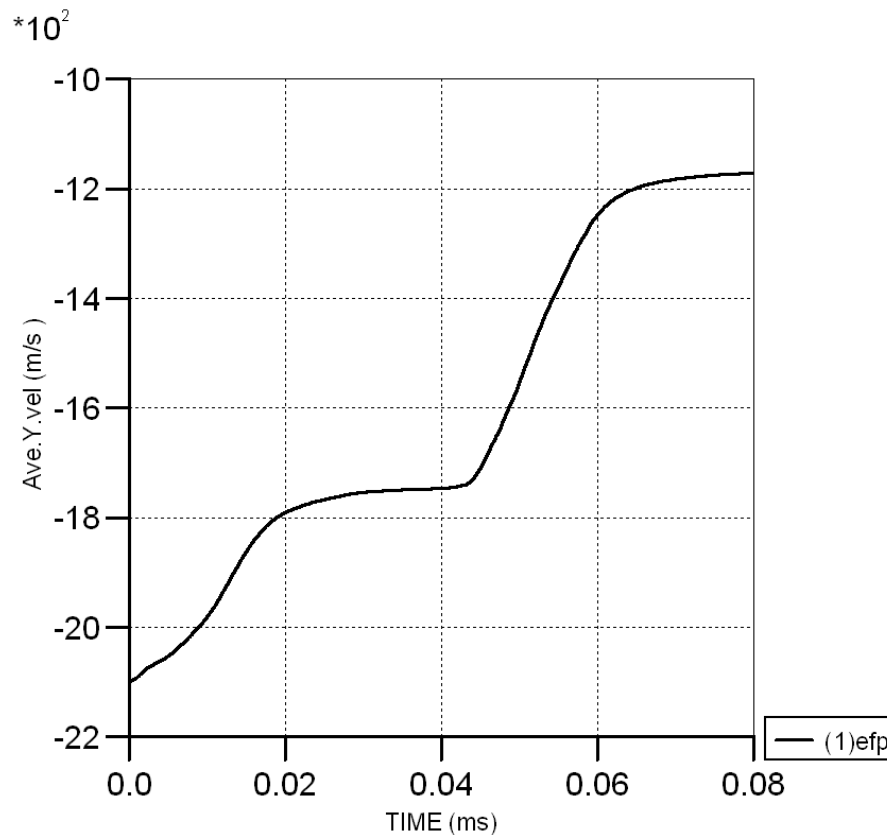

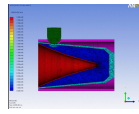

Shock pressure EFP

Gauge History (Ident 0 - efpimpact02)

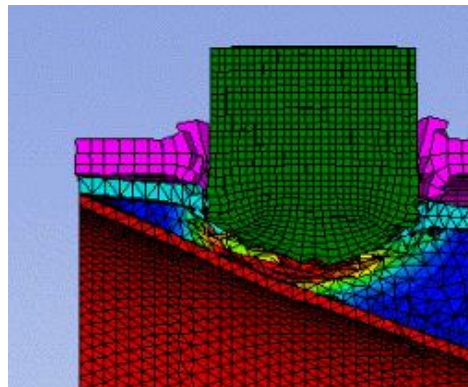
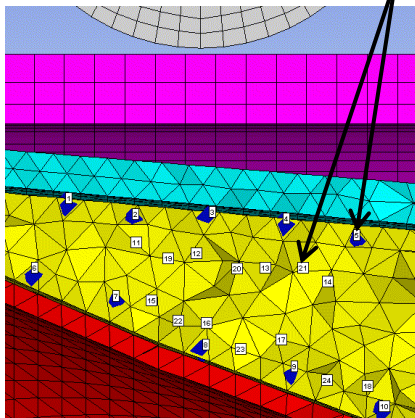
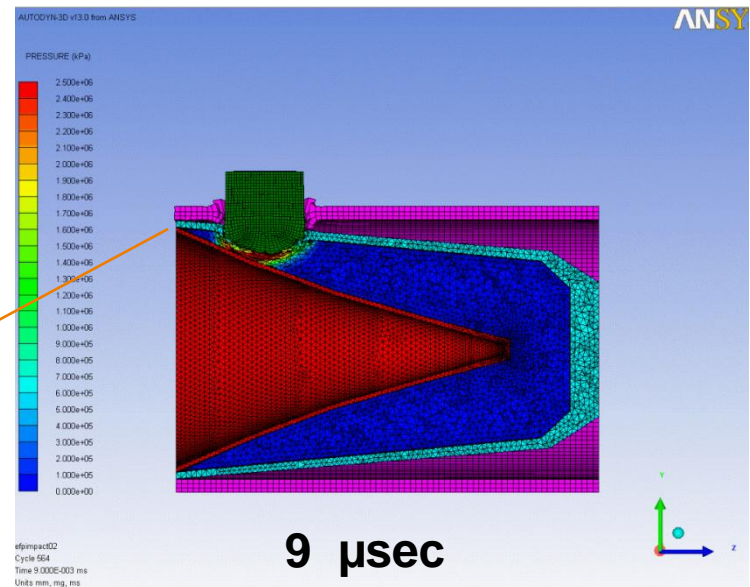
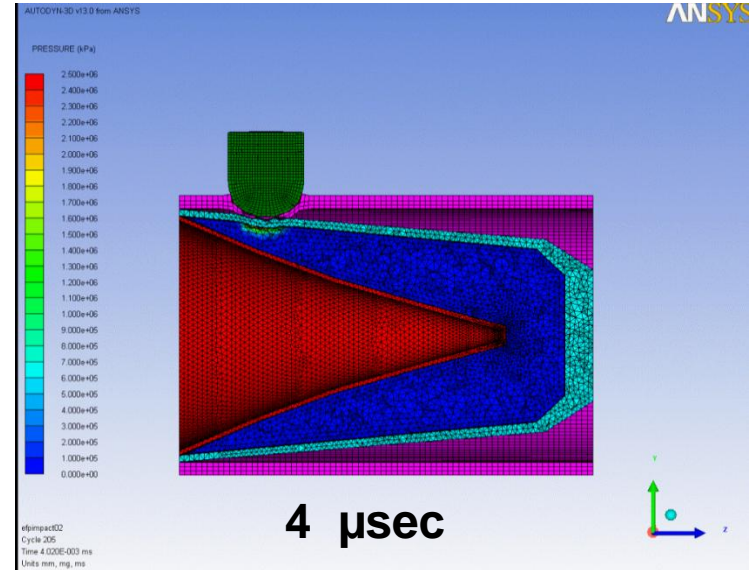
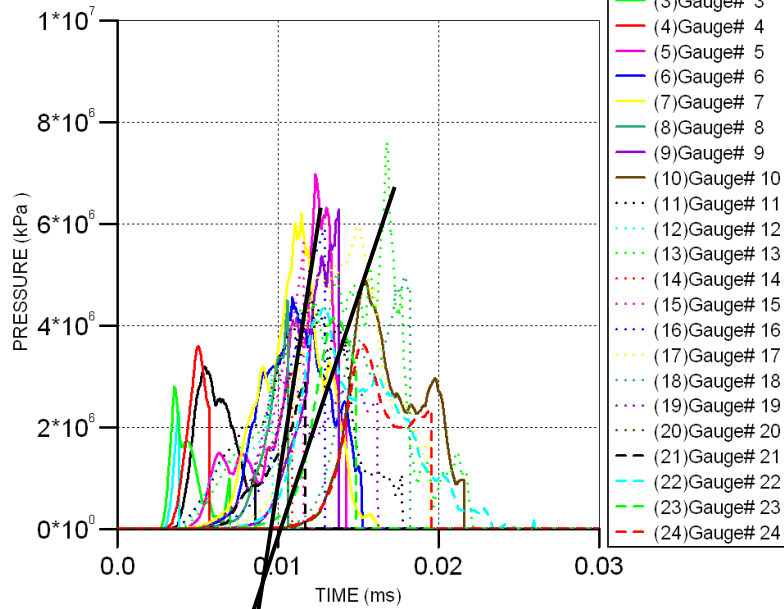

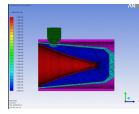

EFP summary

- EFP 19 mm:
 - large area with long shock pulses over 3 GPa,
 - several peaks 1-2 μ sec up to 6 GPa
- EFP 27 mm:
 - Large area with long shock pulses up to 5- 6 GPa (1-2 μ sec)

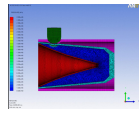

Overview

- Introduction
- Literature on EFP's
- Fragment impact Experiment
- Model/ FI Simulation
- EFP simulation results
- **First comparison**
- Worst case scenario
- Summary



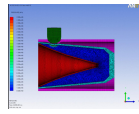

Fragment - 19 mm EFP comparison More high pulses for fragment impact

Gauge History (Ident 0 - efpimpact01)

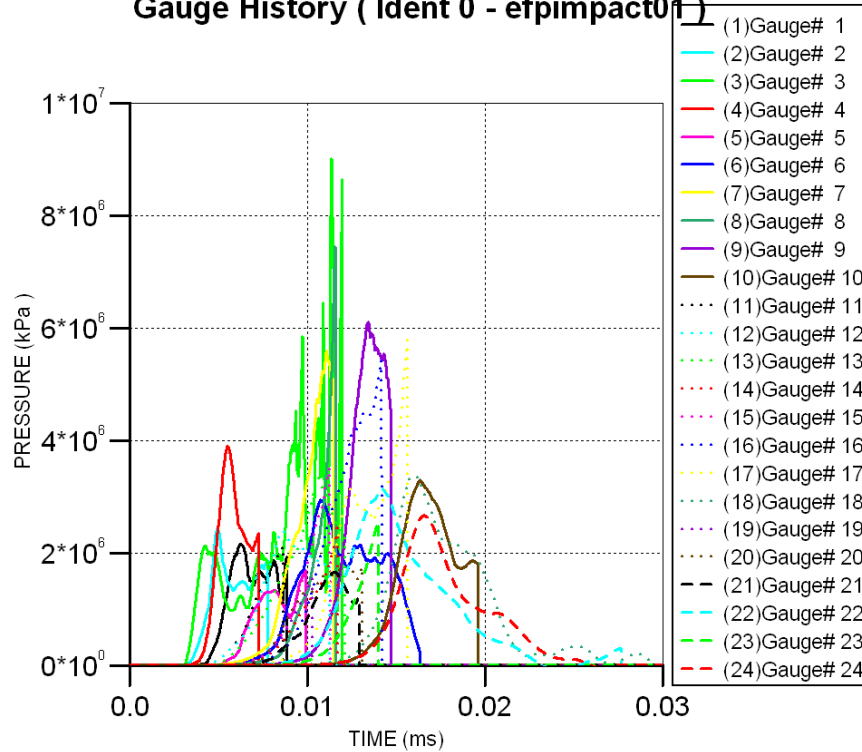

19 mm EFP

Gauge History (Ident 0 - fragimpact06)

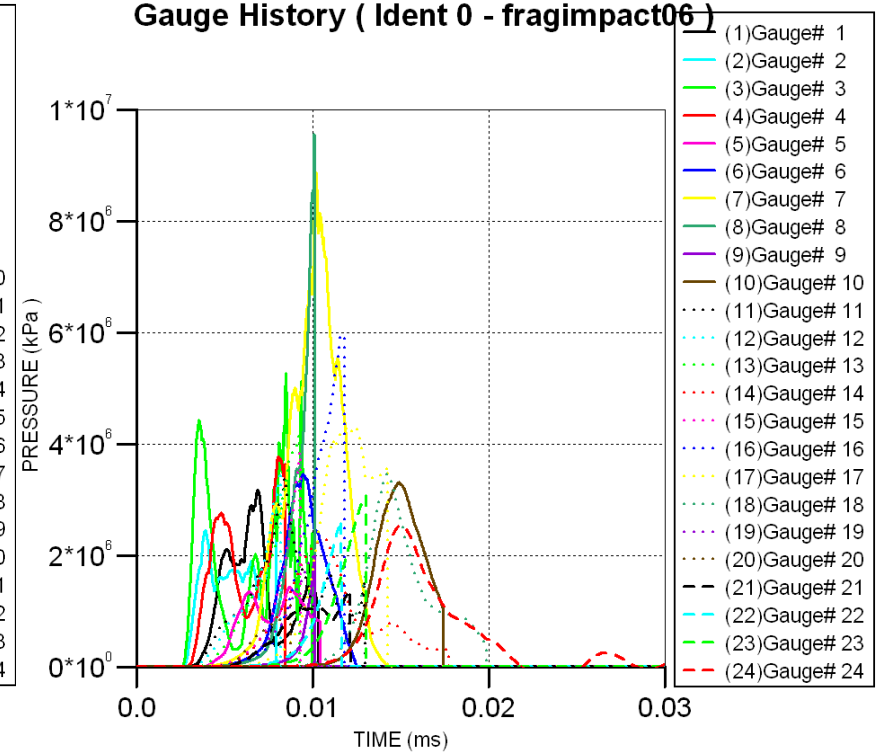

Fragment

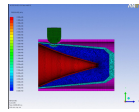

Fragment - 27 mm EFP comparison

More pulses around 6 MPa for EFP

YS

Gauge History (Ident 0 - efpimpact02)

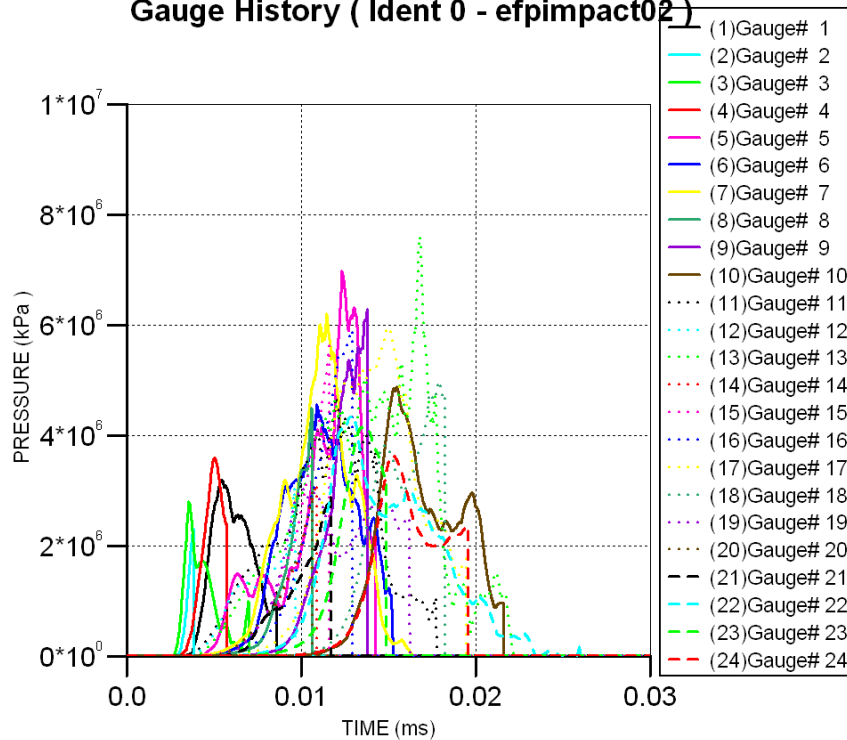

27 mm EFP

Gauge History (Ident 0 - fragimpact06)

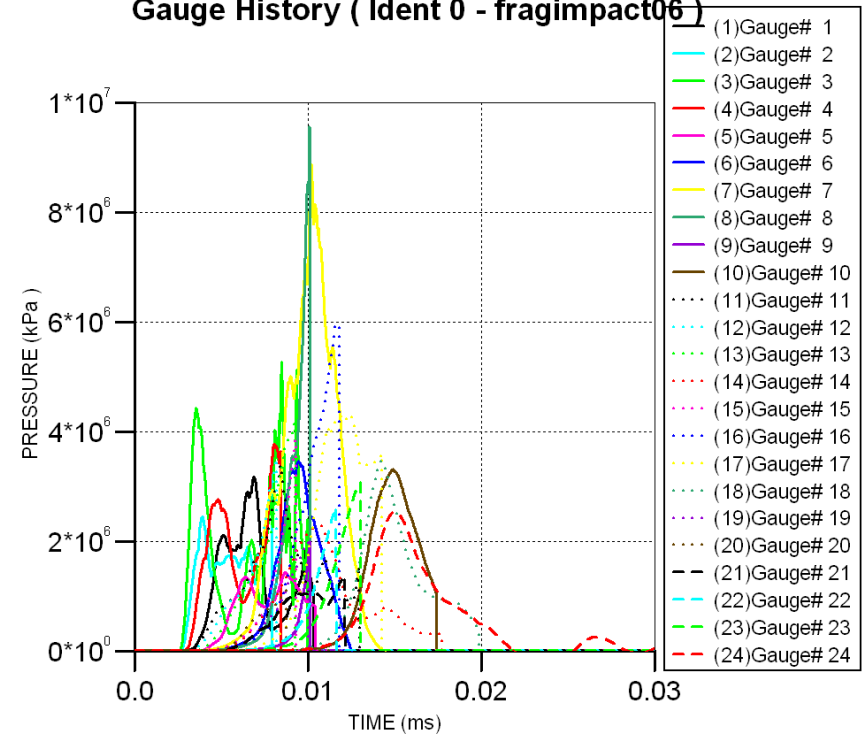

Fragment

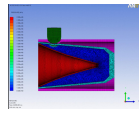

Overview

- Introduction
- Literature on EFP's
- Fragment impact Experiment
- Model/ FI Simulation
- EFP simulation results
- First comparison
- **Worst case scenario**
- Summary



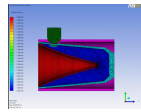

Simulation of FI near end of warhead

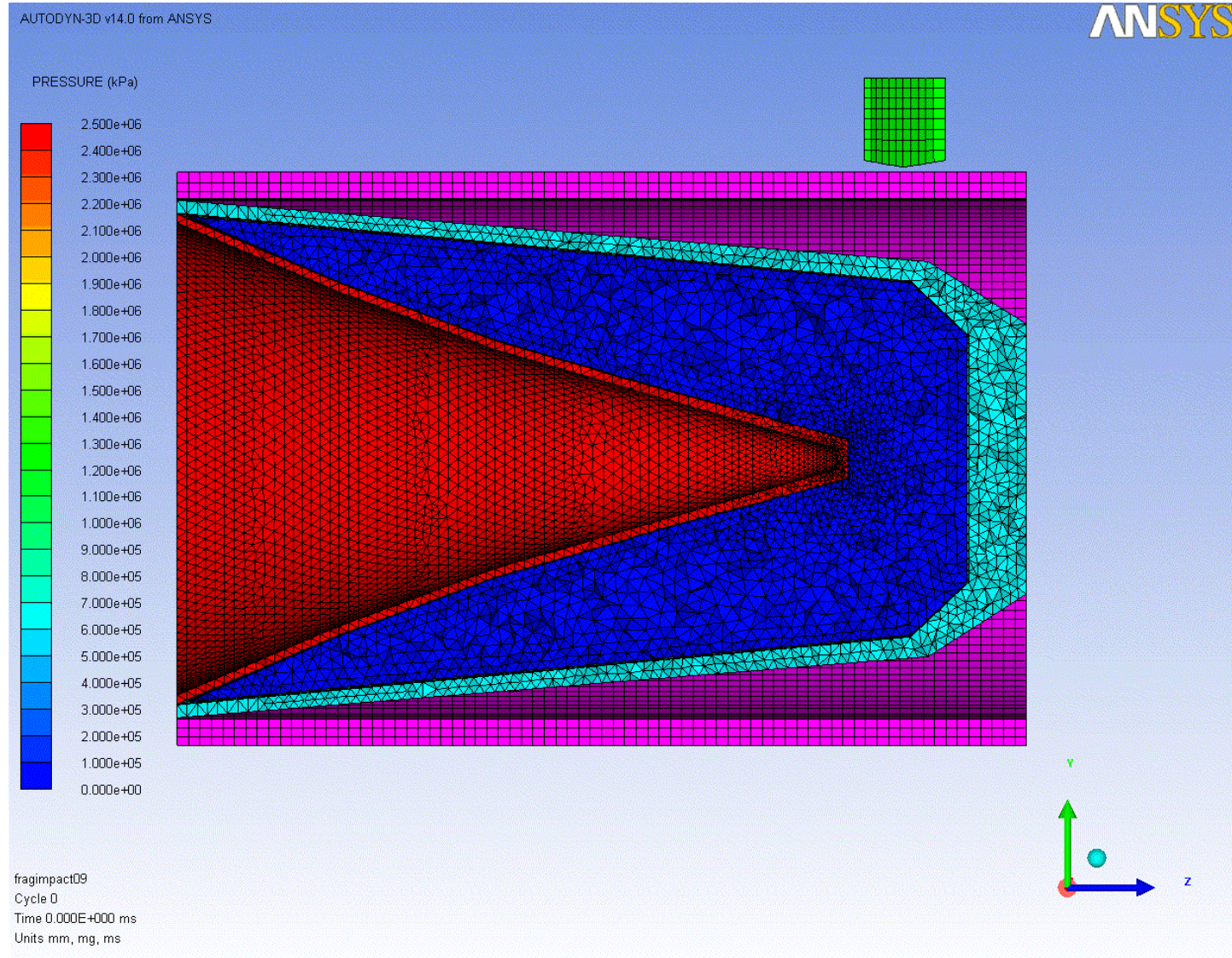

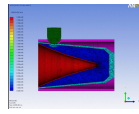

Fragment impact near the end of the warhead

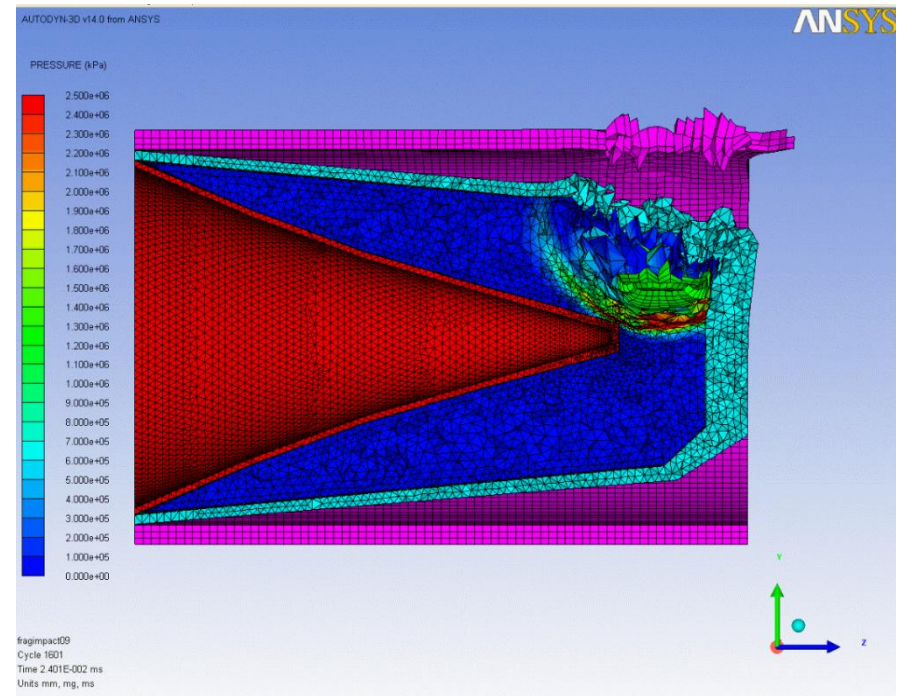
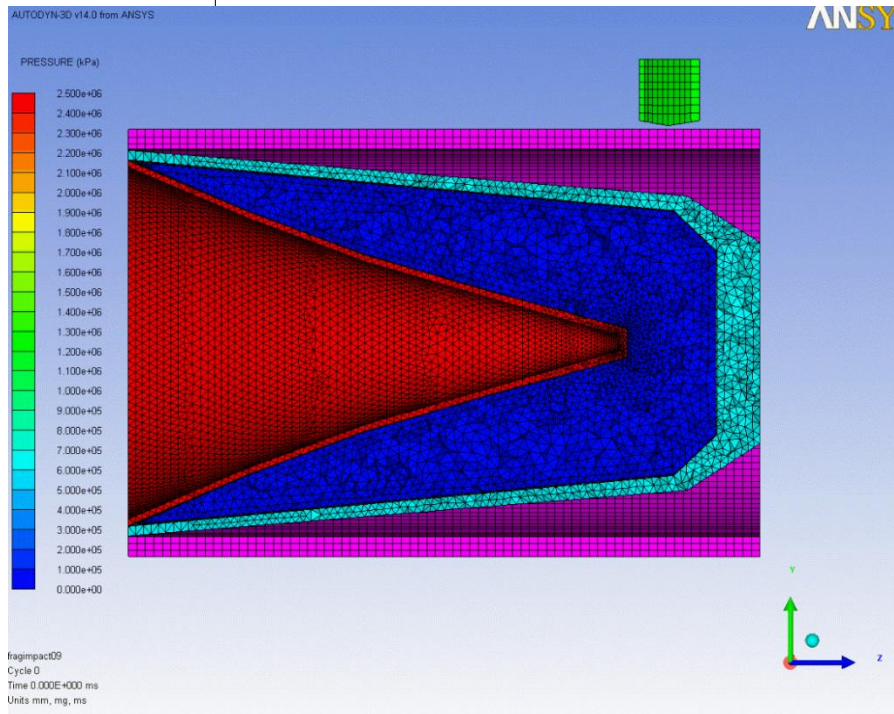

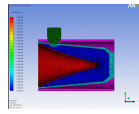

Pressure waves

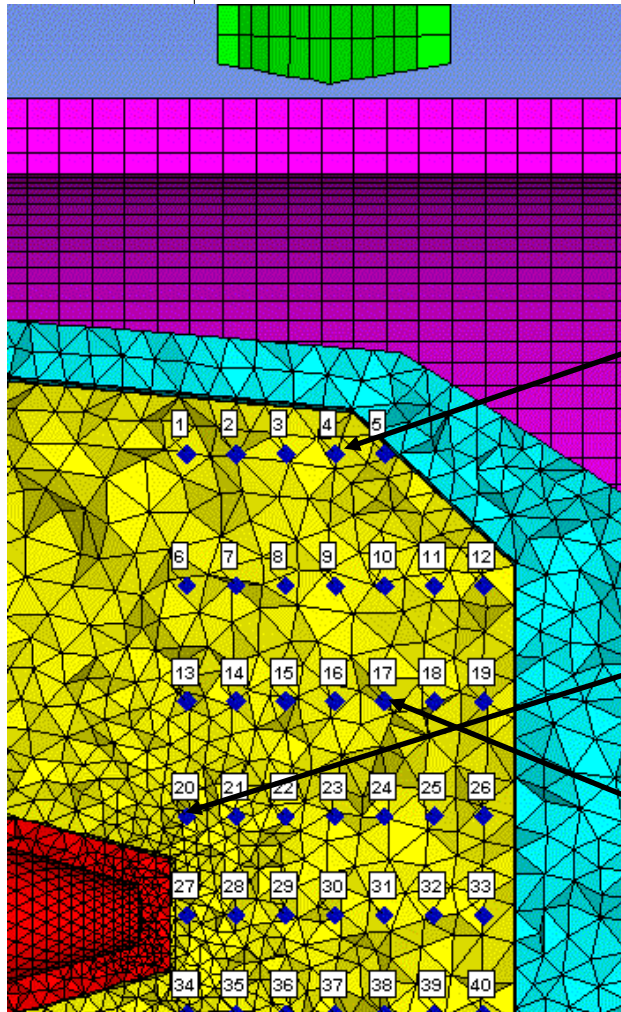

Gauge History (Ident 0 - fragimpact09)

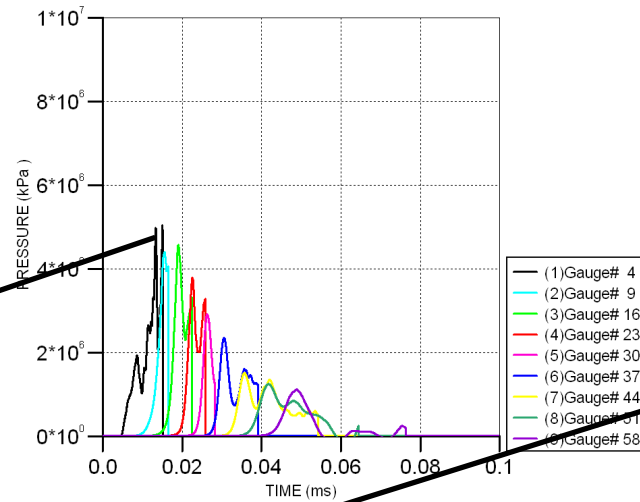

Gauge History (Ident 0 - fragimpact09)

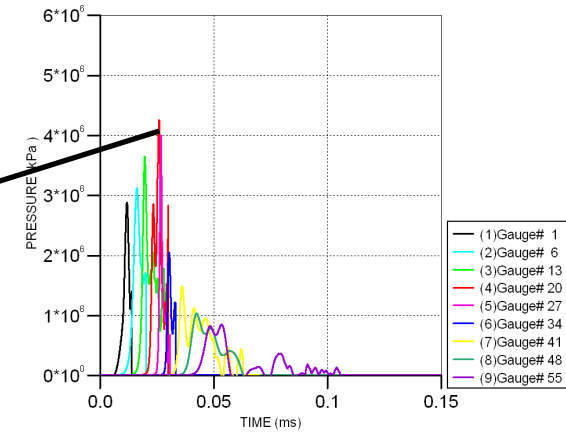

Gauge History (Ident 0 - fragimpact09)

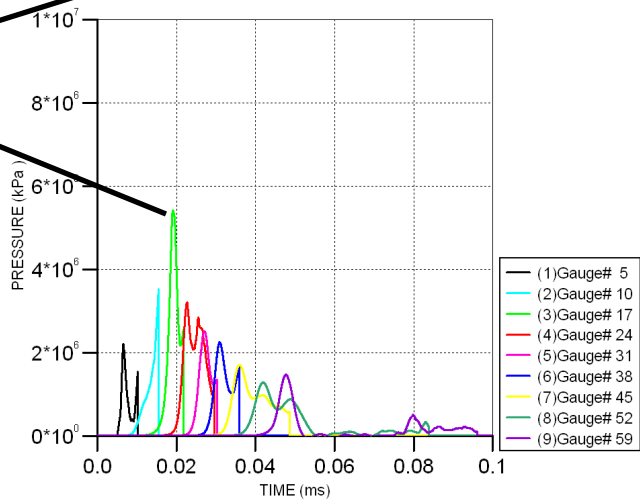

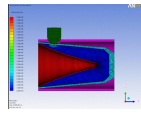

Summary

- Comparison IM fragment at around 2530 m/s and EFP's at 2100 m/s
- Experiment:
 - Fragment impact in centre → Detonation
 - Off centre impact burning i.s.o. detonation
- Simulation:
- EFP impact at 2100 m/s quite comparable to IM fragment impact for thin-walled warheads
- But
 - In case of barrier (protection) probably EFP is in favour due to higher velocity after penetration
 - Thick walled warhead: rarefaction wave is important
 - Confirmation is needed
- Strong dependency on configuration (barriers of walls and reflection waves): Worst case is not in the area with large amounts of explosives!

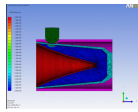

Comparison between IM fragment and EFP impact

Gert Scholtes, Peter Hooijmeijer and Ries Verbeek, TNO Netherlands

Gert.Scholtes@tno.nl tel: +31 (0)6 2280 1250 www.tno.nl/ammunitionsafety

