

**NDIA
Armaments Division
2012
Activity and Status Report**

**Joint Armaments
Conference, Exhibition, & Firing Demonstration**

14-17 May 2012

**Washington State Convention Center
Seattle, Washington**

**Armament Division
Dave Broden --Chairman
Broden Resource Solutions LLC**

Vision

America's leading Defense Industry association
promoting National Security

Mission

ADVOCATE: Cutting-edge technology and superior weapons, equipment, training, and support for the War-Fighter and First Responder

PROMOTE: A vigorous, responsive, Government - Industry National Security Team

PROVIDE: A forum for exchange of information between Industry and Government on National Security issues

"If I were inviting a colleague to join, I'd say the most compelling reason is the prestige of NDIA membership." -- NDIA member

Publications

National DEFENSE Magazine – monthly coverage of defense developments, trends, and issues

“Top Issues” -- published annually to outline key focus areas for NDIA efforts

NDIA Defense Watch —E-Newsletter for Industry and Government

Mega Directory -- published annually in August issue of *National DEFENSE* - provides key information and POC's for corporate member companies and the DoD Acquisition community.

Enabling NDIA Member Links And Access to:
Current Policy, Budgets, Trends, Issues, Technology, and Systems
Helping to Shape Industry Vision—Building Partnership-Ensuring
Readiness

“I skim or read articles (in National DEFENSE Magazine)... because when dealing with clients, I like to be even or have a leg up on the (defense) industry in general.” -- NDIA member

Armament Division

Joint Armaments Conference Theme 2012

- Theme: “Providing The Right Response”

- Small Arms Systems:

- Technology and Systems Sustaining and Evolving Small Arms Capability

- Gun and Missile Systems:

- Force and Weapon Sustainment for a Flexible Theater Environment

- Unconventional and Emerging Armaments:

- Emerging Capabilities and Systems

➔ **Linking Armament Community Personnel, Systems, and Technology**

- Leveraging Commonality--- Enabling Capability
- Ensuring Readiness

Armament Division

Armament Division
Evolving to Reflect
New/Emerging
Systems and
Technology

• Committees:

- **Gun and Missile Systems**
- **Small Arms Systems**
- **Unconventional and Emerging Armaments (New 2011)**

• Division/Committee Leadership:

- **Armament Division: Dave Broden--Chair**
Broden Resource Solutions LLC
- **Gun and Missile Systems:** Steve French
BAE Systems
Ed DePasqual
NAMMO Talley
Greg Hill
Meggitt
- **Small Arms Systems: Brian Berger**
GD-OTS-Canada
- **Unconventional and Emerging Armaments**
Dan Hartman
GD-OTS

New Leadership
Selection 2012

NDIA Armaments Division Scope

Gun and Missile Systems

- Integrated Armament/Weapon Systems
- Direct and Indirect Fire Weapon Systems
 - Cannon Caliber (Weapons and Ammo)
 - Vehicle, Helicopter, Aircraft, UAS, Robotic etc.
 - Tank Cannons and Ammunition
 - Artillery/Mortar (Weapons and Ammo)
 - Shipboard Cannons (Weapons and Ammo)
- Tactical Missiles
- Integration Systems (Fire Control, Turrets, Feed Systems etc.)
- Platform Interface and Integration
- Training Systems
- Modeling and Simulation

• Small Arms Systems

- Integrated Small Arms Systems
 - All Platforms
- Individual Weapons
- Crew Served Weapons
- Ammunition
- Fire Control
- Training Systems
- Modeling and Simulation

Emphasis on:

- Emerging Platforms
- System Integration
- *Enabling Technologies*

Relevant Challenging Topics

- Industrial Base
- Advanced Manufacturing

NDIA Armament Division Scope (Unconventional and Emerging Armaments (New Equip) Committee)

- Futuristic Technology and Capability Vision
 - Lethal, Non-Lethal, Scalable, etc.
 - Defeat, Disable, and Disrupt
 - Platforms (Individual, Conventional, Robotic, UAS etc.)
 - Non Traditional Defeat Mechanisms or Launch Technologies and Systems
 - Electromagnetic
 - Laser
 - High Power Microwave
 - Hypersonic
 - Acoustic
 - Cyber/Electronic
 - Related Enabling Technologies
 - Advanced Fire Control
 - Power
 - Modeling and Simulation
- Thrust:
 - Directed Energy and Related Emerging Technologies and Systems
 - Capabilities:
 - Full Spectrum
 - Adaptable
 - Evolve and Coordinated with other Committees and Divisions

Armament Division Committee Evolving Topics

- **Select and Shape Topics Linked to Shifting DOD Trends/Requirements**
 - Inclusion **of Evolving Platform Applications** in Each Committee
 - Robotics
 - UAV/UAS
 - Other
 - Attention to Impact of **Situation Awareness/Cognitive Technology** on Armament Systems
 - Advanced Fire Control
 - Networked Capabilities
 - Introduction of **Unconventional and Emerging Capabilities**
 - Emphasis **on Priority Enabling Technologies**
 - Power
 - Materials
 - Advanced Sensors, Guidance, Fire Control
 - Modeling and Simulation
 - **Manufacturing Processes and Capability**

Synergism Across
Committees and
Divisions
Ensures Relevance
and
Capability Evolution
Response

Topics Enabling Committee Joint Focus

Armament Division 2012 Activity Highlights

- Executive Committee Strategic Focus
- Confirmed and Implemented Joint Conference Focus 2112 and Beyond
- Added “New” Unconventional/Emerging Armament Committee
- Conference Participation Opportunities Initiatives
- Response to DOD Policy and Budget Changes--- Informing Attendees

- Ensuring "Value Added" Addressing Relevant Topics, Issues, Interests
- Executive Committee Attention to Change

2013 Joint Armaments Conference

- **Location: Indianapolis, Indiana
Indiana Convention Center**
- **Dates: 20-23 May 2013**
- **Themes: Definition In Process**
- **Conference Format: Similar to 2012**
- **Firing Demonstration: Camp Atterbury**
- **Call for Papers: Draft Available**
- **Special Interest Topics:**
 - **Attendees/Presenters are Encouraged to Identify Topic of Interest that the Planning Committee Will Consider Including**
 - **Tutorial Topics Related to Policy and Trends**
 - **Systems and Technology Challenges/Visions—Industry Response**

2012 Strategic Focus Actions

- **Special Focus on Topics Ensuring Industrial Base Adapts to DOD Policy and Budget Changes---Enabling Assured Readiness**
 - Innovation In R&D—Introduction of New Technology and Systems
 - Attention to Advanced Manufacturing Technology and Approach
- **Balancing Industry Attention to:**
 - “Requirements Pull vs. Technology Push”
 - Innovation Initiatives
- **Communicating NDIA Resources and Networking**
 - Policy, Trends, Issues, Technology, Systems Awareness
 - Enabling Innovation Thru Networking and Collaboration
 - Connecting with Other Related NDIA Divisions/Committees
- **Adapting and Strengthening Conference Formats to Attendee Interests**
 - Annual Conferences
 - Special Events
 - Links to Related Divisions
 - Special Topical Forums or Studies
 - Other Innovations

Armament Division Strategic Initiatives

- Seek Innovation in Conference Format , Content, and Media Achieving Presentation Quality Enhancements
- Expand Tutorial Topics and Format—Ensure Focus and Value Addressing DOD Thrusts –Benefiting Attendees
- Establish Joint Conference Locations with Full Capability Firing Ranges
- Ensure Armament Division Committees Reflect Evolution and Changes in Defense Requirements, Acquisition, Budget, and Capability While Ensuring Strength and Readiness of the Industrial Base
- Provide Initiatives for Cost Effective New Capability Development and Deployment
- Expand Emphasis on Enabling Technologies and Resources

Shaping Armament Capability Vision---Providing “Value Added”

NDIA Armament Division

Today

- 1. Advocate
- 2. Promote
- 3. Provide

Small Arms Systems
Vision/Mission

Today

Future

Armament Division Vision/Mission Structure

NDIA
Vision/Mission

Armament
Division
Vision/Mission

Gun and Missile
Systems Vision
Mission

Strategic Plan Vision/Mission/Actions

Future

Unconventional and
Emerging Tech
Vision/Mission

**Committee Vision/Mission Links
to Division with Enables NDIA
Integrated Top to Bottom and
Bottom to Top**

Action Plans Forward

- **Vision:** A network linking government and industry stakeholders in Armament Technologies and Systems effectively communicating Trends, Challenges, Issues, and Program Status Awareness to Armament And Related NDIA Activities
- **Mission:**
 - **Advocate:** Ensure Readiness of Legacy Systems thru Upgrades and maintenance while evolving advanced technologies and capability in armaments and system integration as well as attention to logistics, training, and industrial base. Achieve superior technology and weapon systems for the warfighter responsive to the projected threat scenarios and requirements.
 - **Promote:** A linked network of users, developers, producers of Armament Systems and supporting technologies and capabilities. Integration of government, industry, and academia focused to Armament Capabilities. Expand Network with related NDIA divisions which use or enable armaments. Communicate Status, Issues, Challenges, Solutions.
 - **Provide:** Maintain, expand, and address new formats which enable dialogue among government and industry stakeholders to address Armament evolving technologies, systems, requirements, industrial base, trends, issues, challenges.
- **Actions:**
 - **Specific Annual Action plan will be established for the each mission statement.**
 - **For Committees the Vision and Mission should be stated a Scope/Charter Specific**
 - **Envision that the action list will evolve to a integrated list of topics at the Armament Level**

Armament Division Strategic Initiatives

- Support NDIA, National, and State Education Initiatives to Ensure Availability of the Skilled Technical and Manufacturing Workforce For Science and Technology Superiority
 - Address STEM Initiatives---Address “Skills Gap”
- Utilize NDIA Annual List of “Top Issues” as a Focus for Government and DOD Policy Change Actions
 - Input and Output Interaction
- Shape the Armament Division Activities to Address Interests and Priorities of Attendees —Ensuring Value—Informing the Community—Networking—Addressing Issues—Evolving Vision Focused on Superior Capability, Industrial Base Readiness, and Partnerships of Government and Industry.

Include Attendee Input in Division Activity and Conferences

- Enabling Industry Awareness of Policy and Trends Initiatives
- Ensure Industrial Base Evolving Adjustment Enables Readiness

NDIA Top Issue Topics 2012

- **NDIA Top Issue Objectives:** Guide Association's Advocacy and Educational Activities Throughout Each Year
- **Top Issue Focus Approach:** Broad Topics --Essential to Maintaining Strong Viable Defense Industry Capable of Meeting US National Security Requirements
- **Developed by:** Senior NDIA Industry Leadership--Approved by Board of Directors
- **Distributed to:** Congress, Key Decision Makers with Executive Branch, Allied Governments, Industry Leaders, and Association Membership.



Consideration of Topics and Action by Appropriate Government Officials

Armament Division

"Top Issue Topics"--Member Input

- **Participation in Identifying and Developing Annual "Top Issues":**
 - Attendees/Members Identify Issue Topics
 - Executive Committee Submit Topic, Rationale, and Benefits to Legislative Affairs Committee
- **"Top Issue" Communication to Members**
 - "Top Issue" Annual Document
 - Conference And Symposium Briefings Updates
 - National Defense Magazine
 - NDIA Website
- **"Top Issue"--Action Impact Awareness**
 - To Policy
 - To Programs
 - To Procurement (Contract Type, FAR etc.)
 - To Regulations (e.g. ITAR, FAR, etc.)
 - Small Business
 - "Soft Landing"

NDIA 2012 Top Issue Topics

- 1. Promote Energy Security While Reducing Costs
- 2. Align Defense Industry Capacity and Investment with National Security Requirements, Priorities, and Budgets
- 3. Strengthen the Integrity and Responsiveness of the Acquisition Process
- 4. Pursue Efficiencies While Maintaining the Industrial Base to Ensure Military Readiness
- 5. Adopt a Comprehensive Whole-of-Government Approach to Cyber Policy
- 6. Enable International Competitiveness of US Industrial Base
- 7. Increase Awareness, Opportunity, and Utilization of Small, and Mid-Tier Businesses in Government Contracts

**Issue Focus on Industrial Base—Ensures Awareness,
Response and Action**

Industrial Base Panel Objectives

- *Discuss US Defense Industrial Base* Status, Transition Impact and Vision to Ensure Readiness to Support DOD Capability Requirements Today and In the Future
- *Identify Key Topics* Regarding Industrial Base Status, Transition and Future Capability Objectives
 - *Capture Key Issues, Needs, and Challenges*
- *Identify Suggestions for Action* by Industry, DOD, and Congress that Will Ensure Timely Readiness
- *Provide Topical Input* to NDIA Government Policy Advisory Division(GPAD) Top Defense Policy Issue Selection/Action for 2013
- Expand Industrial Base *Status/Action Awareness*
- Define *Go-Forward Suggestions*

Key Focus Issues and Topics

- **Industrial Base Status and Transition Awareness**
- **Subcontractor and Source Capability and Structure**
- **DOD Policy and Budget Reduction**
- **Acquisition Policy Innovation**
- **Impact and Approach to Research and Development**
- **Link Business Focus to Changes/Shifts of DOD Policy and Priorities**
- **Intellectual Property Status and Innovation**
- **Industry Investment Considerations and Return**
- **Maintaining and Modernizing Production Base**
- **Assuring Readiness**
- **Human Capital Availability and Capability**

Armament Division

Defense Industrial Base Strategy Focus

- 1. National Defense Capability is Dependent on Industrial Base Readiness
- 2. US Budget Trends Require Adjustments to DOD Budget
- 3. Changes/Downturn of International Conflict Levels Impact Requirements
- 4. Industrial Base Has Evolved from “Vertical Integrated Companies” to “Horizontal Integration Structure”---Increasing Readiness Risk
- 5. Industry Capability Must Adapt to Budget and Priority Decisions
 - Adapting Must be Readiness Focused
 - “Warm Base”
 - Ensured Sourcing Network or System Effective Open Architecture
 - Modernized Capability
- 6. Evolving New Technologies and Systems Must be Integrated Into Industrial Base Structure
- 7. “Lessons Learned” Offer Risk Management Experience
- 8. Manufacturing Technology Advances are Key to Industrial Base
- 9. Manpower Resources Must be Addressed

Evolving Industrial Base Vision

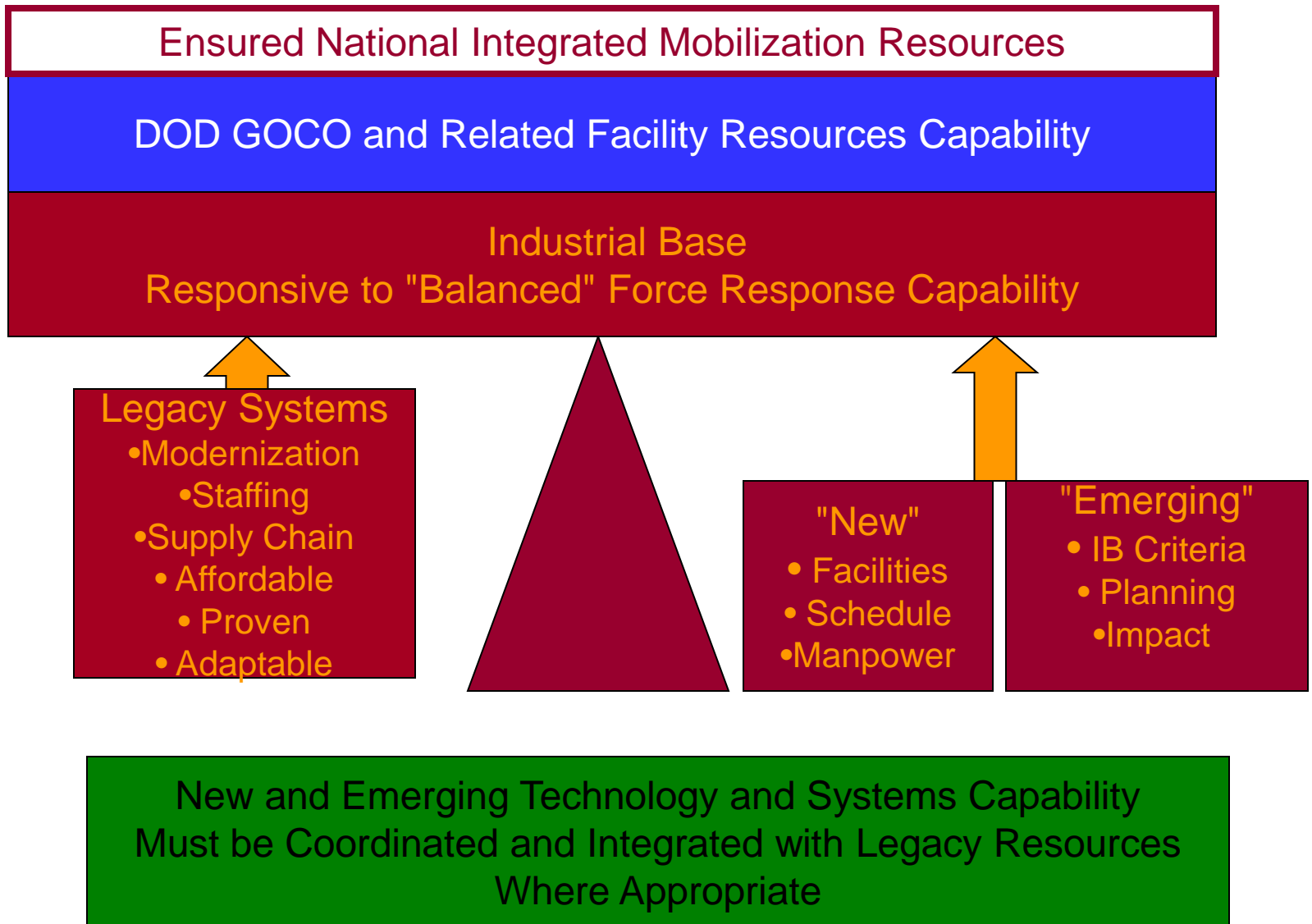

DOD Industrial Base Perspective Bottom Line

US Defense Industrial Base Evolution/Readiness

- 1. DOD Industrial Base Structural Evolution is Critical to the Readiness Vision
- 2. Industrial Base is Broader –Includes Diverse OEM’s and Increasingly Complex
- 3. Transition has and Will continue to be Focused on a Horizontal Based Industry Structure –thus Demanding Understanding of the Total Supply Chain of Materials—Components—Subsystems and Integration
- 4. Growth and Evolution of Technology Must Be Included in Industrial Base Plans
- 5. Man Tech Funds or Focus must Reach Down Thru the System to Component Sources
- 6. Facility Modernization is required across the horizontal base
- 7. Manpower Availability Increasingly Critical Path Focus

DOD Industrial Base Planning Is Addressing The
Evolving Structure,
Technology, Manufacturing, and Critical Path Factors

- *On-Going Continuous Integration of Government, Industry (All Levels of Companies) Must be Focus to Ensure Readiness*

Armament Division—2012 Challenges

- Ensure Armament Division Joint Committee Synergism Focus— Link Individual Committee Objectives for Common Technology/Systems
- Structuring Conferences With Topics Focused and Relevant to DOD Thrusts, Attendee Interests, And Industrial Base Readiness
- Establishing Industry Response to: "Balanced Capability and Assured Readiness--"Balance Legacy Capability, “New Systems”, and Readiness
- Strengthening Partnerships
 - Across NDIA Divisions/Committees
 - Government, Industry, and Academia
 - US and International Community
- Ensuring that Conferences Integrate Innovative and Visionary Capability Complementing Legacy Resources— Applying Enabling Technologies—
Establishing Industrial Base Readiness
- Membership/Attendee Participation in "Top Issues" and "Division Focus"

Armament Division Take-Away Thoughts

- **NDIA Vision** Promoting National Security Establishes Leadership Enabling Industry-Government Partnership for Security Strength and Readiness
 - Armament Division and Participating Attendees Enable The Vision
- **Advocate:** Armament Division Demonstrates Continued Leadership In New Technology and Systems—Conference Content Communicates
- **Promote:** Armament Division Links Industry and Government to Common Themes and Topics—Effective In Depth Networking
- **Provide:** Armament Division Conferences, Related Activity, and Networking Strengthens and Expands Understanding, Technology, and Partnership Focused to Industrial Base Warfighter Capability

Armament Division—Three Committees Are Focused to the
NDIA Vision/Mission
Involving the Community--Communicating—Enabling
Readiness

Armament Division Take-Away Thoughts

- NDIA *Mission is Focused* to Strength, Responsiveness, Readiness, and Human Resources
- NDIA Strategic Focus Committed to Continuous Improvement-----
 - *"Value Added", Responsive, Adaptable, and Impacting Issues, and Ensuring Resources and Skilled Human Capital*
- *Collaboration and Joint Conference Activity* Offers Efficiency and Expanded Scope and Depth Available to Members
- *Member/Attendee Input/Interests* is Key Conference Planning Focus
- NDIA Conferences, Communications, and *Networking Enables Adaptability* --Ensures Understanding of DOD Focus, Changes, Trends
- *Training and Education* Conference Segment Provided Awareness of Policy and DOD Changes and Focus Activity

Armament Division Looking Ahead

- **Thoughts for Consideration:**
- **1. Does NDIA Activity Assist/Enable Armament Community?**
 - Networking
 - Conference Organization, Structure, Content—What Specifically?
 - NDIA Communications—”National Defense”; “Top Five”; Website, Special Communications
- **2. Is Armament Division Providing a Vision of Evolving Armament Capability Today and the Future—Is Capability Evolution Communicated Effectively?**
- **3. Are Industrial Base Considerations Effectively Communicated and Discussed to Enable Understanding and Action Ensuring Readiness for Legacy, Evolving, and Emerging Systems and Technology?**

**Armament Division Provides Information Enabling Government/Industry Links –
Transitioning Capability and Readiness Vision**

**NDIA Armament Division Seeks to Adapt to Armament Community Interests,
Challenges, and Activities**

Armament Division

Looking Ahead

- **NDIA Leadership is Focused to Ensuring Industrial Base Strength thru Partnership with Government for Capability Superiority and Readiness**
- **Armament Division---Conference and Activities Linked to Communicate Evolving Requirements, Policy, Technology and Systems**
- **NDIA Activities Enable DOD Changes and Challenges to Evolve to Opportunities**
- **Major Factors Ahead:**
 - **Budget Uncertainty and Downturn**
 - **Product Requirement Uncertainty**
 - **Continued Rapid Technology Evolution/Revolution**
 - **Manufacturing Technology and Approach Advances**
 - **Industrial Base Challenges, Realignment**
 - **Human Capital Skills Availability Concern**

**NDIA Armament Division Provides Networking Forum for Armament and Associated Community Dialogue and Collaboration
Building and Ensuring Awareness and Capability**

Industrial Base Structural Changes Past, Current, Future

US Defense Industrial Base Evolution/Readiness

Vertical Source Integration Past Prior to 1950-1960

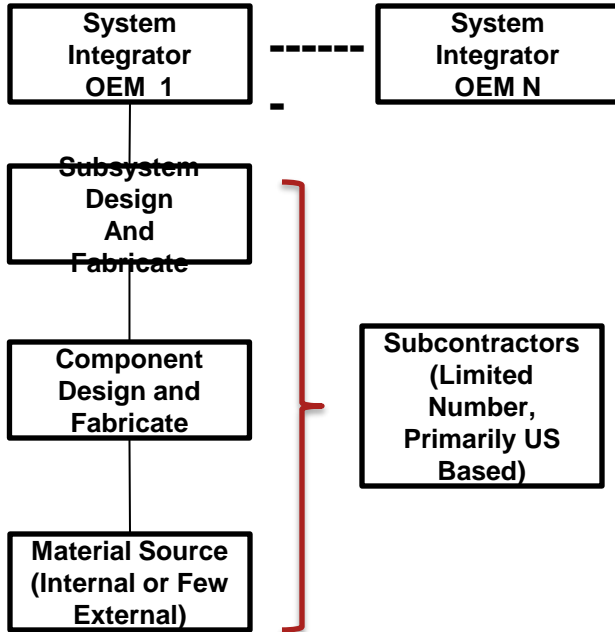

Note: Number and Type of OEM's was small compared to Evolution of Systems and Technology Post Approx. 1960

Horizontal Source Integration Current and Future

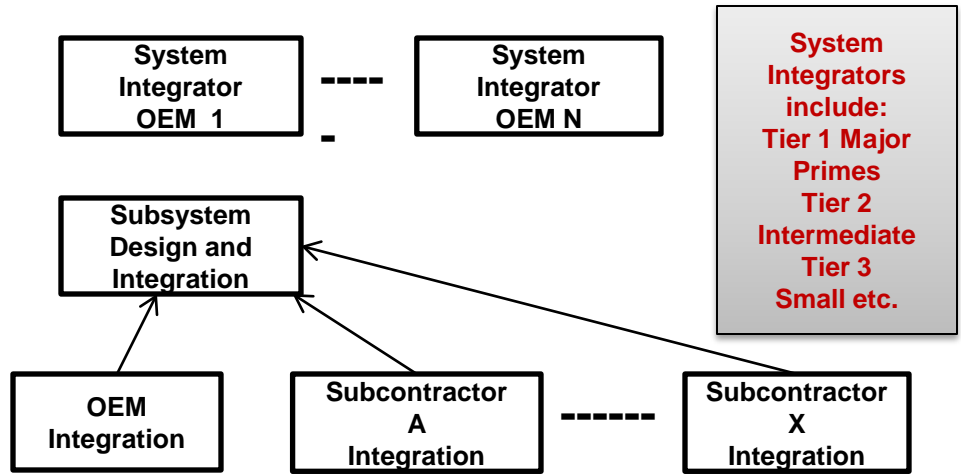

Expanding and Specialized Subcontractor Network



Component Sources Expanding, Unique and Critical Path US and International Based



Material Sources Support Component Manufacturers— Sources are US and International—Commodity Price and Availability Driven

Industrial Base Evolution

Industrial Base Preparedness Vision

Industrial Base Element	Prior Structure	Current and Future
<ul style="list-style-type: none"> • Government 	<ul style="list-style-type: none"> • Government Owned and Operated Resources 	<ul style="list-style-type: none"> • Minimal Government Resources • Company Operation of Government Facilities
<ul style="list-style-type: none"> • Industry within Each Country 	<ul style="list-style-type: none"> • Primary Industry Focus • Multiple Companies 	<ul style="list-style-type: none"> • Expanded Number of Companies and Technologies
<ul style="list-style-type: none"> • Industry International 	<ul style="list-style-type: none"> • Very Limited 	<ul style="list-style-type: none"> • Expanding Multi-national corporations
<ul style="list-style-type: none"> • Industry Structure 	<ul style="list-style-type: none"> • Each Company had Vertical Supply Capability 	<ul style="list-style-type: none"> • Focus on Horizontal Supply Chain
<ul style="list-style-type: none"> • Component Supply Chain 	<ul style="list-style-type: none"> • Vertical Supply Provides Internal Focus 	<ul style="list-style-type: none"> • Horizontal Supply Chain Requires Expanded Preparedness Plans
<ul style="list-style-type: none"> • Technology Evolution 	<ul style="list-style-type: none"> • Base not Planned for Technology Change 	<ul style="list-style-type: none"> • Base Must Address New and Evolving Technology
<ul style="list-style-type: none"> • Defense International Market Impact 	<ul style="list-style-type: none"> • Limited International Procurement 	<ul style="list-style-type: none"> • International Procurements

**Evolving Structure, and Operation of Industrial Base Requires International Vision
Enabling Assured Preparedness**

Armament Division Strategic Initiatives

- Achieve Integrated Armament Division Culture Focused on:
 - “Joint Links of Technology and Systems Across Committees”
 - While
 - Ensuring and Maintaining Individual Committee Depth and Strength
- Leverage Links with Other NDIA Divisions and Committees:
 - Interdivisional Links, Discussions, and Joint Conference Participation
 - Other Divisions Connecting with Armament Division
 - Armament Division Reaching Out to Other Divisions
- Mature “New” Unconventional/Emerging Armaments Committee Operation and Activity
- Ensure Committee Leadership Shaping Conference Content/Presentations
- Ensure Conference Focus Addresses Changing DOD Thrusts, Priorities, and Budgets—Industrial Base Evolution Awareness

Dynamic List—Evolving to Meeting Attendee and Committee Objectives

Armament Division 2012 Strategic Focus Vision

-