



*Office of the Deputy Chief of Staff, G-4*  
*Sustainment Directorate*  
*Munitions Division*

Deputy Chief of Staff, G-4  
Headquarters, Department of the Army





# With all he's carrying



## Where would he be without Ammo ?



# MISSION

**Provide Army Staff responsibility and oversight for policy, plans, and resources for:**

- Conventional ammunition**
- Missiles**
- Toxic chemical storage**
- Ammunition surveillance**
- Demilitarization**
- Explosives safety and environmental compliance**

## **Specifics:**

Distribution of the Army's munitions stockpile.

Perform ammunition and missile stockpile management functions.

Develop policy for and monitor ammo surveillance and environmental compliance.

Oversight on emerging missile, ammo and ammo information Mgt systems.





# How Ammo Works

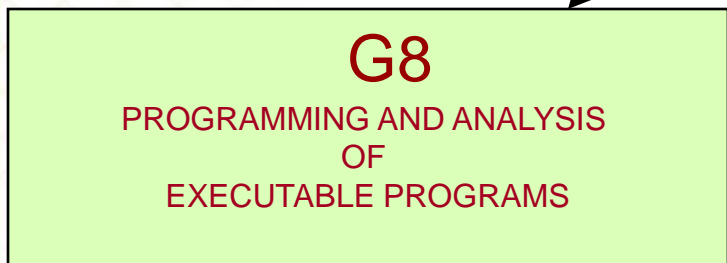
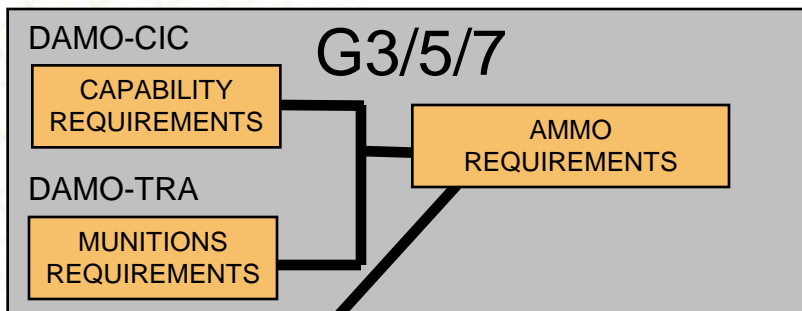

MACOMs/USAMC

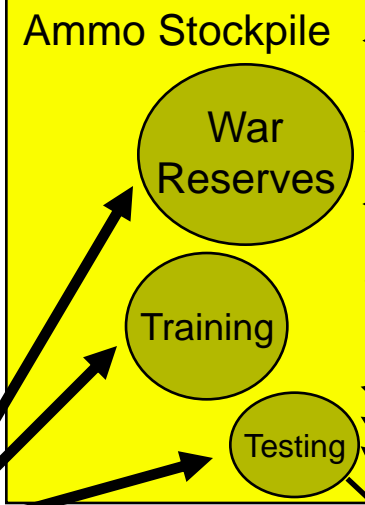

**G4/USAMC/ASA(ALT)**

Logistical Functions

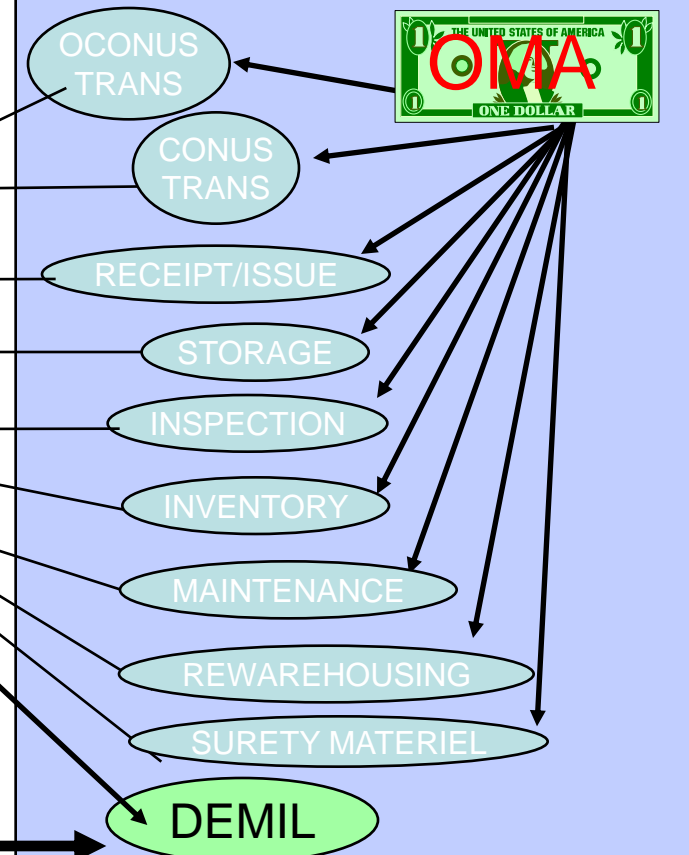

USAMC/ASA(ALT)/PEO AMMO

Procurement Functions

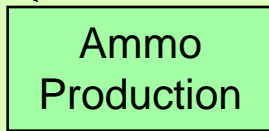

(Overhead)

(Rounds)

DEMIL



# Organizational Structure

UNCLASSIFIED

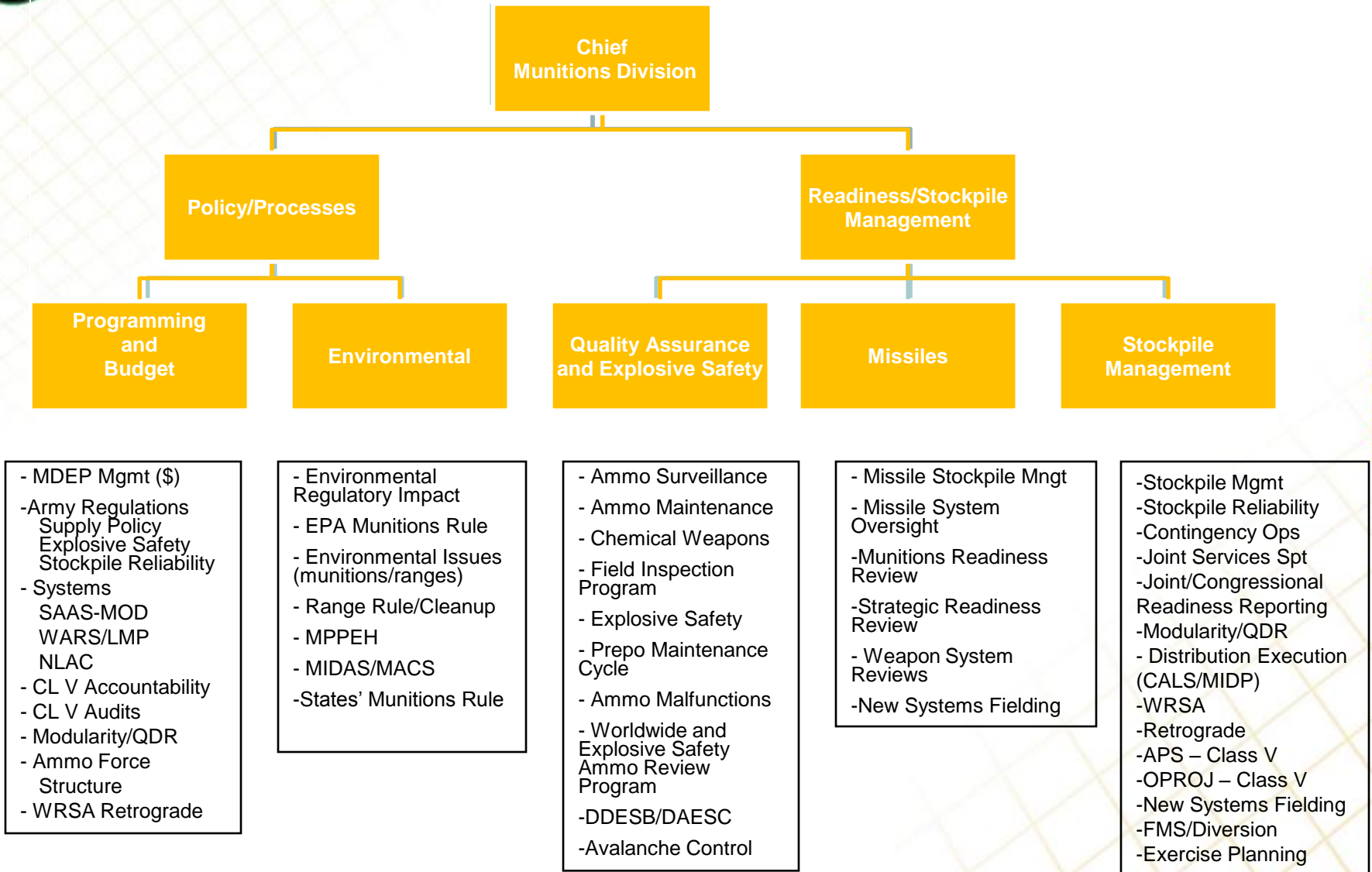



# TOP 10

UNCLASSIFIED

- |  |                         |
|--|-------------------------|
| 1. Current Operations                                | Ms. Carlson/Mr. Young   |
| 2. G-4 Transformation                                | ALL                     |
| 3. Stockpile Distribution / Reporting                | Ms. Carlson             |
| 4. Ammo Readiness POM/Budget/ Industrial base *      | Mr. Carr                |
| 5. Munitions Environmental Policies *                | Mr. Dallstream          |
| 6. Stockpile Readiness (Surveillance & Maintenance)* | Mr. Young               |
| 7. Centralized Ammunition Management                 | Mr. Young/Mr. Carr      |
| 8. CALs and Missile Distribution *                   | Ms. Carlson/Mr. Mattero |
| 9. Future Ammunition Logistics System                | CW5 Lewis               |
| 10. Future Ammunition Logistics Force                | CW5 Lewis               |

\* Extra visibility periodically



# CONVENTIONAL AMMUNITION READINESS

**AACS  
SINGLE  
MANAGER**

**CONVENTIONAL AMMO  
MANAGEMENT AMC (OMA)**

**DOD EXPLOSIVE SAFETY  
DDESB (RDT&E)**

**AANS  
NON-SMCA**

**CMD AMC, (OMA)**

**CMD USAMC, USARPAC,  
HQDA (OMA)**

**ARMY SAFETY (OMA) DA**

**NLAC (OMA) DA**

**ARMY EXPLOSIVE  
SAFETY DAC (RDT&E)**

**MUNITIONS SURVIVABILITY  
& LOGISTICS (RDT&E)**

**ASTC  
TOXIC CHEM  
STORAGE**

**CHEMICAL WEAPON  
STOCKPILE STORAGE  
CMA (OMA)**

**ASDE  
CONVENTIONAL  
AMMO DEMIL  
PEO AMMO**

**MISSILE DEMIL  
(PAA)**

**CONVENTIONAL AMMO  
DEMIL (PAA) SMCA**

**CONVENTIONAL AMMO  
DEMIL (PAA) NON-SMCA**

**NON ARMY MISSILE  
DEMIL (PAA)**

**CONVENTIONAL AMMO  
DEMIL RDT&E**

**OMA Funding**

**PAA**  
**RDT&E**

AMERICA'S ARMY: THE STRENGTH OF THE NATION™



# Conventional Ammunition Demilitarization

- As the Single Manager for Conventional Ammunition (SMCA), the Army is responsible for programming, budgeting and execution of the conventional ammunition demilitarization for all the Services
  - Munitions identified as SMCA managed
  - Non-SMCA managed
  - Non-Army missiles
  - Army Missiles





# The Program Objective Memorandum (POM) Process

- ❑ Requirements Build:
  - Demil Costs
  - Generations
  - Stockpile Reduction
- ❑ Sustaining Program Evaluation Group (PEG) Briefing:
  - Validation of Requirement
  - Establish Critical Level
- ❑ Prioritization:
  - G-4 Programs Prioritized
  - G-4 Total Obligation Authority Spread Based on Army Priorities



# Where we are heading - "Sourcing Future Requirements"

- ❑ Retrograde and redistribution from OEF
- ❑ Posturing for the "next" fight
- ❑ Redistribution to support Rebasing
- ❑ Support to COCOMs
- ❑ Future Ammunition Logistics System



# Challenges

## ❑ Funding

### ▪ OMA

- Taking Risk in Surveillance, Stockpile Mgmt
  - Limits flexibility to redistribute
  - Increases depot release time

### ▪ PAA - Demil

- Growing demil stockpile creates storage inefficiencies
- Postpones Demil to out years, more expensive
- Cluster Munitions Demil

## ❑ Administration Relook of Current Treaties

## ❑ Distribution Management

- Asset distribution/Visibility
- Rightsizing World-Wide inventory to meet war fighters need.
- Accurate forecasting (What, Where, How Much and When)





# Munitions Division Personnel

<b>Ms. Susan Carlson (Division Chief)</b>	<b>703 614-1191</b>
<b>Mr. Jim Young (QASAS)</b>	<b>703 614-3857</b>
<b>Mr. Steve Carr (Ammo Manager)</b>	<b>703 614-1151</b>
<b>CW5 William Lewis</b>	<b>703 693-8919</b>
<b>Mr. Sam Dallstream (Ammo Manager)</b>	<b>703 614-4058</b>
<b>Mr. Frank Mattero (Missiles)</b>	<b>703 614-1216</b>
<b>Mr. Pat Moses</b>	<b>703 614-4039</b>



# QUESTIONS ?