



# SPECIAL OPERATIONS FORCES INDUSTRY CONFERENCE

**Col Eric Forsyth**  
Program Executive Officer

---

PORTFOLIO  
REVIEW

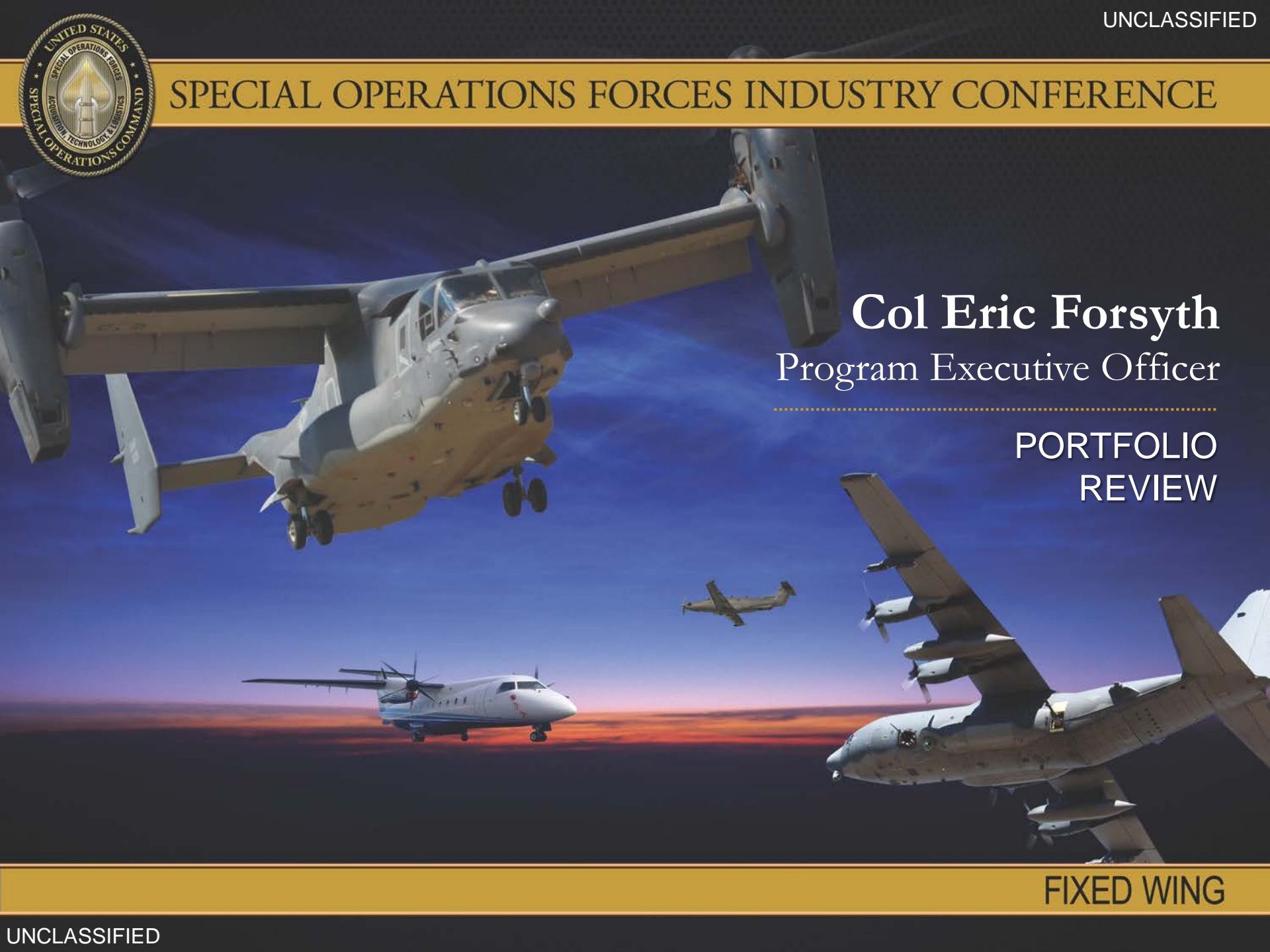

FIXED WING

# MISSION STATEMENT

**To deliver Special Operations (SO)-peculiar manned and unmanned fixed wing airpower capabilities to effectively enable Special Operations Forces (SOF).**

**PEO-FW partners with the Warfighter and various development and support organizations to synchronize acquisition activities to field an array of advanced technology sensors, defensive countermeasures, advanced avionics, munitions and gun systems, and mission training systems.**

**The low-density, high-demand nature of the SOF fixed wing fleet is a key driver in the acquisition approaches used to continue to improve and sustain the force. The high operational tempo of these aircraft requires innovative means to incorporate capability and sustainment improvements while ensuring adequate aircraft availability.**

# PEO-FW PORTFOLIO

UNCLASSIFIED

## ISR - FIND



MQ-1B Predator

MQ-1C Gray Eagle



MQ-9 Reaper

RQ-20A Puma



MEUAS 1.5  
Scan Eagle

MEUAS 2.0  
Aerosonde



JAVAMAN - MC-12

U-28/PC-12



## MOBILITY- INFILTRATE



CV-22  
Osprey

EC-130J  
Commando Solo



Dornier 328  
C-146

M-28 C-145A



MC-130P  
Shadow

MC-130J  
Commando II



MC-130H  
Talon II



## STRIKE-FINISH



MQ-9 Reaper

MQ-1C Gray Eagle



AC-130U Spooky

AC-130H  
Specter



AC-130W  
Stinger II



AC-130J  
Ghost rider



SOPGM



EMERGING TECHNOLOGY  
TRAINING & MISSION PLANNING

UNCLASSIFIED

# PEO-FW ORGANIZATION

UNCLASSIFIED

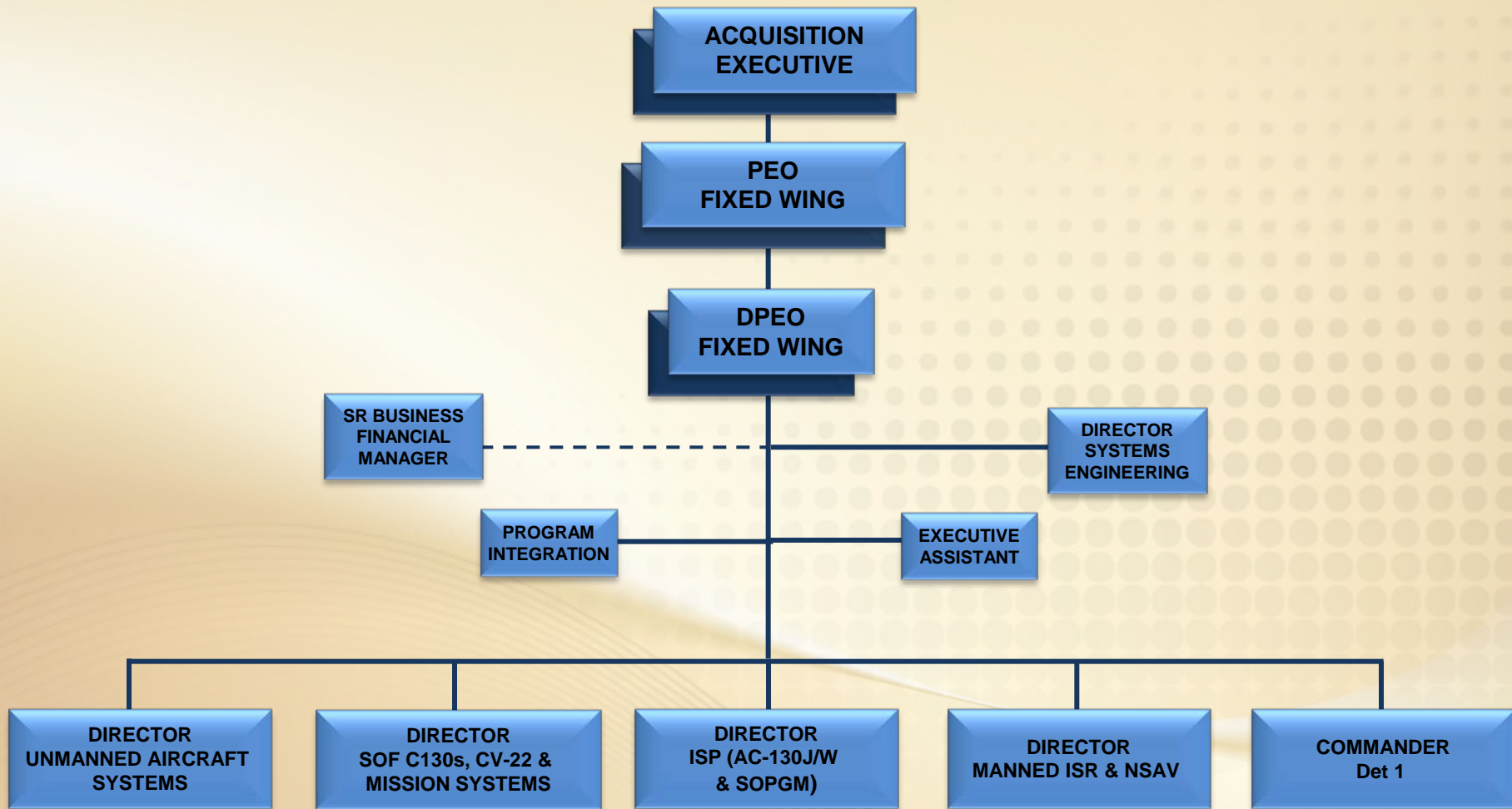

UNCLASSIFIED

# PEO-FW GOVERNMENT ACQUISITION SUPPORT ENTERPRISE





# SPECIAL OPERATIONS FORCES INDUSTRY CONFERENCE

UNMANNED  
AIRCRAFT  
SYSTEMS

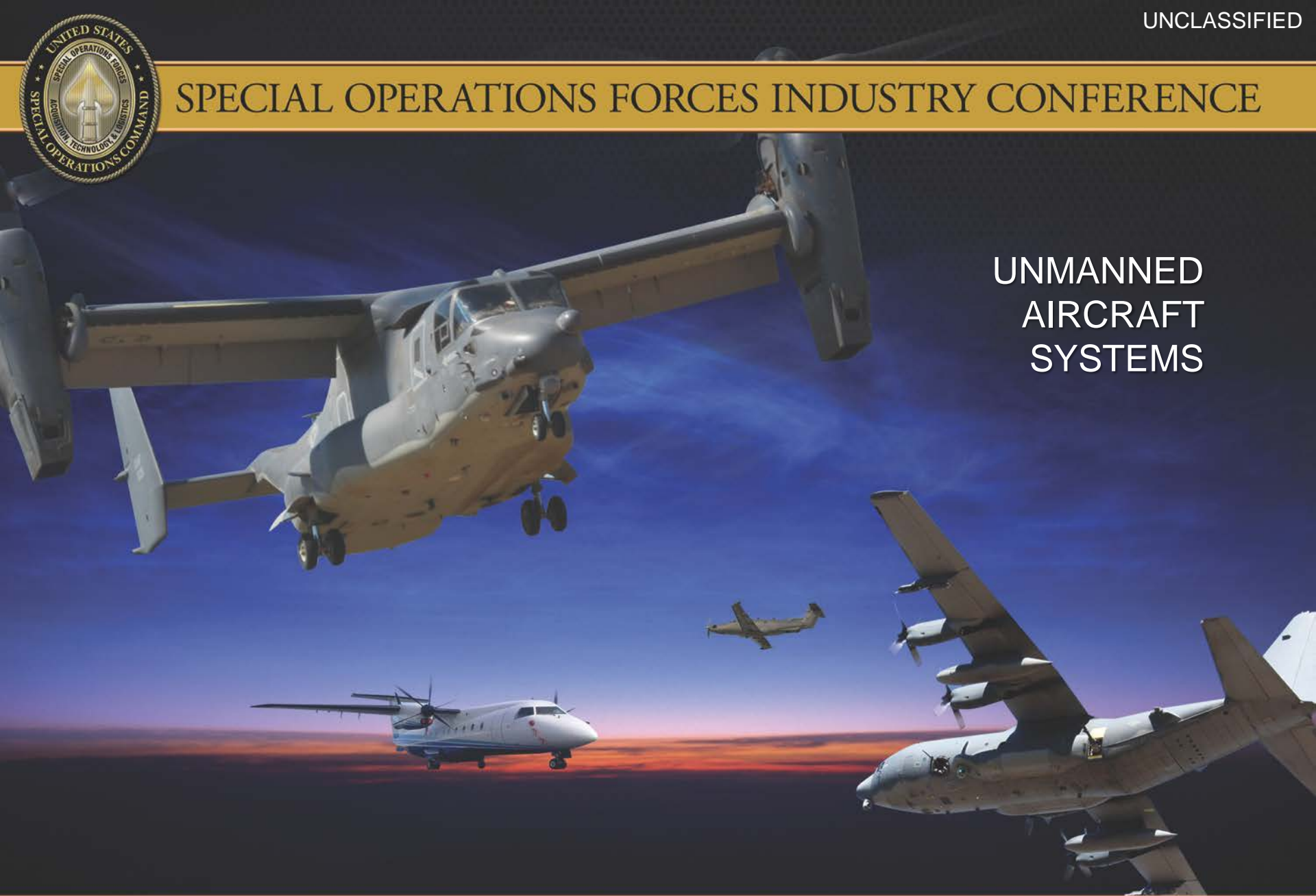

FIXED WING

# UNMANNED INTELLIGENCE, SURVEILLANCE, & RECONNAISSANCE (ISR) SYSTEMS

## FW Priorities

- Craft and Execute Acquisition Plans for GOGO and COCO Gp II/III UAS efforts in support of Emerging Tactical ISR Requirements
- Craft Strategy to Optimize Dev and Proc of Modular, Miniature ISR Payloads for Tactical ISR
- Continue Rapid Fielding of ISR and Strike on MQ-9 and MQ-1C
- Improve Endurance, Signature, Power, Modular Payload Architecture
- Rapidly Develop and Insert Game Changing Technologies



MQ-9 Reaper



MQ-1C Gray Eagle



MQ-1B Predator



Aerosonde



Scan Eagle



Puma AE

## FY15/16 Planned Efforts

- Extended Range
- HD and EW Dev and Int
- Moving Target Tracking
- Full Motion Video Cueing
- In-Flight Payload Switching

# UNMANNED ISR SYSTEMS

UNCLASSIFIED

- Provide Rapidly Deployable Multi-Intelligence ISR Capability in Denied Environments
- Provide Persistent Intelligence, Surveillance, Reconnaissance and Targeting



## ACQUISITION STRATEGY

- Operational Systems in Sustainment with Evolutionary Technology Insertions
- Contractor Owned & Operated Services

## PERIOD OF PERFORMANCE

- Various

## MILESTONES

- Pre Milestone C, Post Milestone C, Tech Insertion Invest, and Sustainment

## POINT OF CONTACT

- 813.826.9482 TILO

## FUNDING

- FY15: \$ 173M
- FY16: \$ 149M

## CURRENT CONTRACT/OEM

- General Atomics (MQ-1B, MQ-1C, MQ-9)
- Raytheon (FMV Sensor)
- Northrop Grumman (Payloads)
- Insitu (Scan Eagle) AAI (Aerosonde)
- AeroVironment (Puma AE)

UNCLASSIFIED





# SPECIAL OPERATIONS FORCES INDUSTRY CONFERENCE

SOF C-130s/  
CV-22/  
MISSION  
SYSTEMS



FIXED WING

# SOF C-130s

## FW Priorities

- Rapidly Develop and Insert Game Changing Survivability and Sensor Technologies via Responsive Test and Open Architectures
- Continue to Procure and Sustain Legacy SOF C-130 Aircraft through Planned Retirement Dates
- Re-baseline MCTF Program to Support Updated User Requirements



## FY15/16 Planned Efforts

- Defensive Systems
- ESA Hardware & SW Integration
- Pod-Based C4ISR Capabilities
- EC-130J Demod and Upgrades
- Special Mission Processor
- Terrain Following Radar

# SOF C-130s

ACQUISITION



- Provide Low-level Infil/Exfil and Resupply of SOF in Hostile or Denied Areas
- Provide Armed Over Watch, CAS, and Precision Strike to Ground Forces
- Provide In-flight Refueling of SOF Assets
- Provide Airborne MISO Support

## ACQUISITION STRATEGY

- Operational System in Sustainment with Evolutionary Technology Insertions
- New Aircraft to Recap Legacy Fleet

## PERIOD OF PERFORMANCE

- Various

## MILESTONES

- Post Milestone C: Legacy Aircraft
- Milestone B: MC-130J Inc 3 / MCTF
- Pre-Milestone B: RF Countermeasures

## POINT OF CONTACT

- 813.826.9482 (TILO)

## FUNDING

- FY15: \$107M
- FY16: \$188M

## CURRENT CONTRACT/OEM

- Lockheed Martin (C-130J, Inc3)
- Scientific Research Corp (MCTF)
- TBD (RFCM)

# CV-22B OSPREY

## FW Priorities

- Transition from CV-22 Production to SOF Mod/Sustainment
- Rapidly Develop and Insert Game Changing Survivability and Sensor Technologies
- Current and Future Responsive Acquisition (Low Cost Mods)
- Enhance Situational Awareness
- Field APQ-187 Silent Knight Radar



## FY15/16 Planned Efforts

- Sustainment Upgrades
- Communication Enhancements
- Survivability Enhancements
- Digital Map Upgrades
- ESA Hardware and SW Integration

# CV-22B OSPREY

ACQUISITION

- Provides Long-range, High Speed, All Weather, Infiltration, Exfiltration, and Resupply Of Teams In Hostile, Denied, and Politically Sensitive Areas in a Single Period of Darkness



## ACQUISITION STRATEGY

- Operational systems in sustainment with evolutionary technology insertions

## PERIOD OF PERFORMANCE

- Various

## MILESTONES

- Post Milestone C: Production & sustainment through a joint performance based logistics contract

## POINT OF CONTACT

- 813.826.9482 (TILO)

## FUNDING

- FY15: \$22M
- FY16: \$19M

## CURRENT CONTRACT/OEM

- Multiple contracts
- Bell-Boeing prime (OEM)
- Final aircraft delivery in 2016

# SOF MISSION SYSTEMS

## FW Priorities

- Rapidly Develop and Insert Game Changing Technologies via Responsive Test and Open Architecture Approaches
- Maintain Simulator Concurrency
- Ruggedized and Mobile Devices

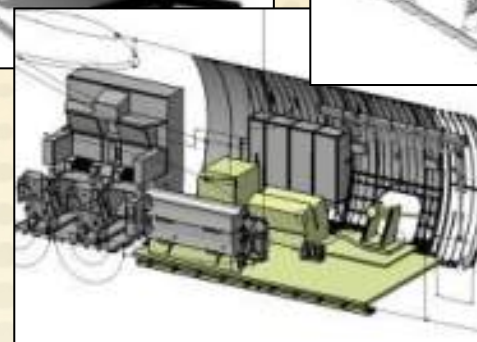
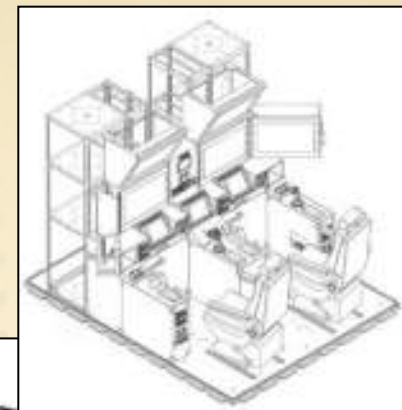

## FY15/16 Planned Efforts

- AC-130J Training System Upgrades
- Simulator Block Updates
- SOMPE SW Application Development
- SOMPE Hardware Development

# SOF MISSION SYSTEMS

- Provide Realistic Combat Simulation to SOF Forces Via Aircrew Training Devices
- Enables Mission Planning and Execution for SOF Forces Across All Components



## ACQUISITION STRATEGY

- Existing, competed contracts for minor acquisitions and CLS
- Limited/full & open competition contracts for major acquisitions

## PERIOD OF PERFORMANCE

- Various

## MILESTONES

- MS C: AC-130J Training System
- Post-MS C: SBUD
- Post-MS C: SOMPE

## POINT OF CONTACT

- 813.826.9482 (TILO)

## FUNDING

- FY15: \$35M
- FY16: \$30M

## CURRENT CONTRACT/OEM

- AC-130J SIM: Lockheed Martin
- SBUD: Lockheed Martin, Sierra Nevada Corp, Opinicus, FSI,
- SOMPE: NTS, SAIC, Wyle, Nova,

# DO-328 "COUGAR"

## **PEO-FW Demo Platform for ISR, Weapons, Survivability and Comms**

- Do-328: Large / Flexible Platform
- 335 Knots, 31K Ceiling, 1150 Miles
- Modular Antenna Bays
- Sponsons: 300lb pod

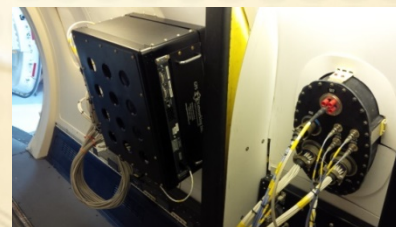
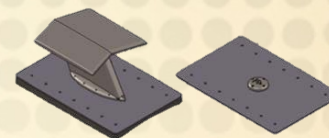
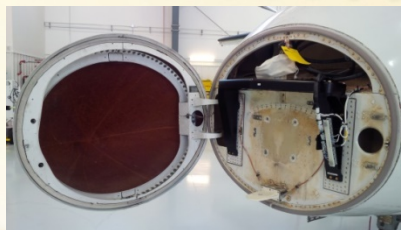

**Industry Must Have User / Command Sponsor**





# SPECIAL OPERATIONS FORCES INDUSTRY CONFERENCE

AC-130J  
GHOST RIDER

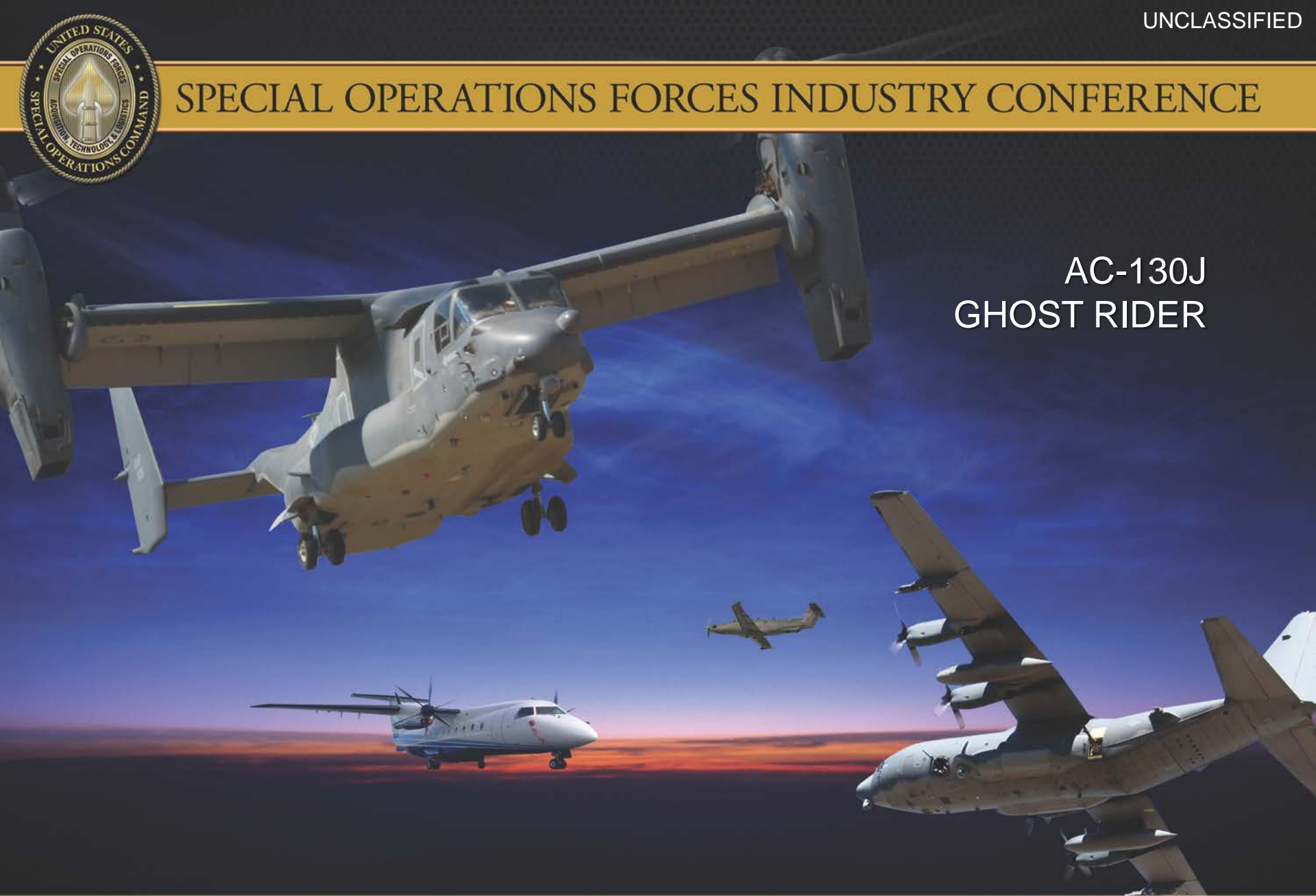

FIXED WING

# AC-130J GHOSTRIDER

## FW Priorities

- Complete DT Flight Test and Begin OT Training
- Reduce CLS by 10% by FY17
- Implement Open Architecture to Integrate Game Changing Strike and Sensor Technologies



## FY15/16 Planned Efforts

- Integration of 105MM Gun
- EO/IR Sensor Upgrade
- Expanded Crew Stations
- Hellfire Missile Integration

# AC-130J GHOSTRIDER

**Provide Close Air Support  
and Air Interdiction in  
Support of Ground Forces**

## Desired Future Capabilities

- Enhanced Defensive Countermeasures
- Improved Communications
- Directed Energy Weapons



### ACQUISITION STRATEGY

- Modify 37 Donor MC-130 Aircraft with Precision Strike Package
- Utilize AC-130W as Risk Reduction

### PERIOD OF PERFORMANCE

- Various

### MILESTONES

- Post MS B, Engineering and Manufacturing Development
- Preparing for IOT&E – Winter 2015

### POINT OF CONTACT

- 813.826.9482 (TILO)

### FUNDING

- FY15: \$182M
- FY16: \$234M

### CURRENT CONTRACT/OEM

- SOFSA/Lockheed Martin, SNC, L3 WesCam, ForceX, Various



# SPECIAL OPERATIONS FORCES INDUSTRY CONFERENCE

STAND OFF  
PRECISION GUIDED  
MUNITIONS (SOPGM)



FIXED WING

# STANDOFF PRECISION GUIDED MUNITIONS (SOPGM)

UNCLASSIFIED

## FW Priorities

- Rapidly Develop/Insert Game-Changing Strike Technologies for SOF Platforms
- Improve 1<sup>st</sup> Pass Lethality
- Expand Moving Target Capabilities
- Enhanced Lethal Warheads (CLT Compatible)
- Better Seekers for All Weather/All Terrain Use
- Selectable Effects Munitions
- Affordability-Linked to Service Common

## FY15/16 Planned Efforts

- Complete Hellfire Integration on AC-130W/J
- Investigate Non-Line of Site Munitions
- CRADA: Rapid Integration and Demonstration of Programs



UNCLASSIFIED

# STAND-OFF PRECISION GUIDED MUNITIONS (SOPGM)

- Buy and Integrate Mix of SOF Unique and Service Common Precision Guided Weapons for Irregular Warfare
- Interfaces:
  - SOF Battle Management System (BMS)
  - RPA OFP Software
  - Common Launch Tube (CLT) or Wing Deployment

**ACQUISITION STRATEGY**

- Commodity Buy
- Integrate Service Common

**PERIOD OF PERFORMANCE**

- Various

**MILESTONES**

- Laser Small Diameter Bomb Fielded Nov 14
- Hellfire Testing/Fielding FY16
- SDB II Integration FY17

**POINT OF CONTACT**

- 813.826.9482 (TILO)

**FUNDING**

- FY15: \$80M
- FY16: \$87M

**CURRENT CONTRACT/OEM**

- Raytheon Missile Systems
- Boeing Defense, Space & Security
- Dynetics
- Textron



# SPECIAL OPERATIONS FORCES INDUSTRY CONFERENCE

MANNED ISR AND  
NON-STANDARD  
AVIATION SYSTEMS



FIXED WING

# MANNED ISR AND NON-STANDARD AVIATION SYSTEMS

## FW Priorities

- Initiate Acquisition Planning Activities with the Goal of Reducing PEO-FW Portfolio CLS Costs By 10% By FY17 Through Efficiencies, Partnerships and Other Innovative Techniques
- Execute Next Gen Manned ISR Requirements Development and Analysis as well as Appropriate Acquisition Planning Activities in Support of Program Start Later in the FYDP



## FY15/16 Planned Efforts:

- Procure and Modify C-146 NSAV Aircraft
- Complete HD Full Motion Video Upgrades on U-28s



# MANNED ISR AND NON-STANDARD AVIATION SYSTEMS

- Provide a Manned Fixed Wing Capability for Tactical ISR in Support of Theater Special Operations Forces
- Provide Dedicated Mobility to Theater Special Operations Forces in Austere and Remote Locations



## ACQUISITION STRATEGY

- Procure commercial aircraft and modify to meet SOF mobility and ISR requirements

## PERIOD OF PERFORMANCE

- Various

## MILESTONES

- ISR: Complete HD Mods on U-28s; Recapitalize MC-12 GOCO Fleet
- NSAV: Production, Deployment, Operations, & Sustainment

## POINT OF CONTACT

- 813.826.9482 (TILO)

## FUNDING

- FY15: \$587M
- FY16: \$672M

## CURRENT CONTRACT/OEM

- L3 Com
- Sierra Nevada Corp