

HERO Compliant Electric Primer for Tank Ammunition

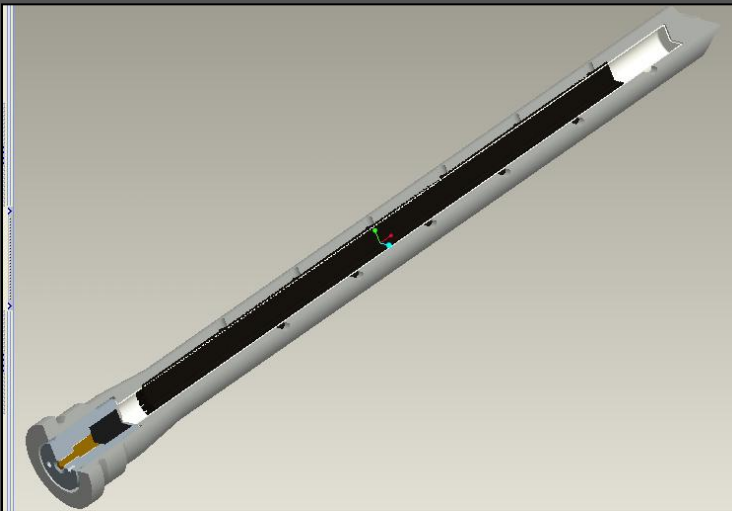

Presented by:
Jason Mishock

22 April 2015

- **Definition:**

- HERO (Hazards of Electromagnetic Radiation to Ordnance)**

- **Primer testing was conducted to ensure that the radios used on the M1A1/A2 SEP Abrams tank platforms were compatible with the 120mm main gun ammunition.**
- **Test results showed that the current primer did not have an issue with the current tank configuration but still did not meet the HERO requirements.**
- **Ammunition currently does not meet the MIL-STD-464A for HERO compliance. This restricts the handling of the ammunition while outside its packaging container when in certain RF (Radio Frequency) conditions. One example is during shipment on Naval ships.**

Maximum human body absorption of RF energy is from 40MHz - 90MHz

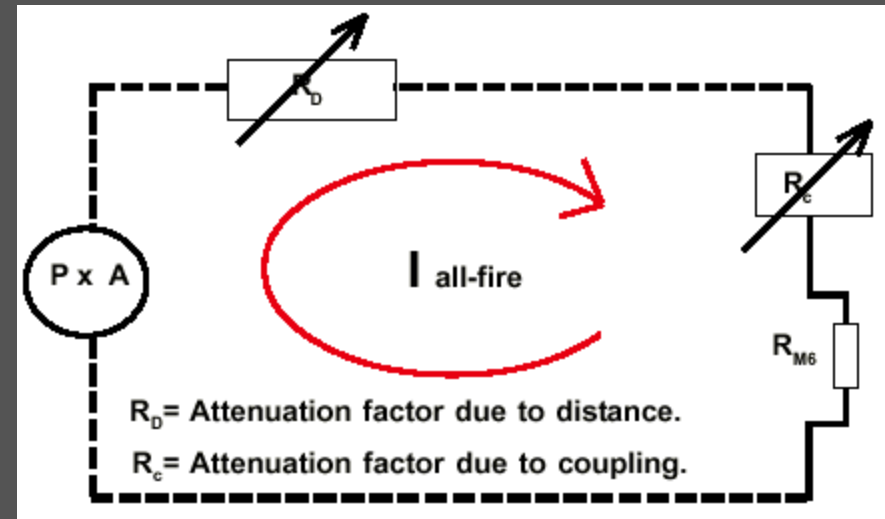
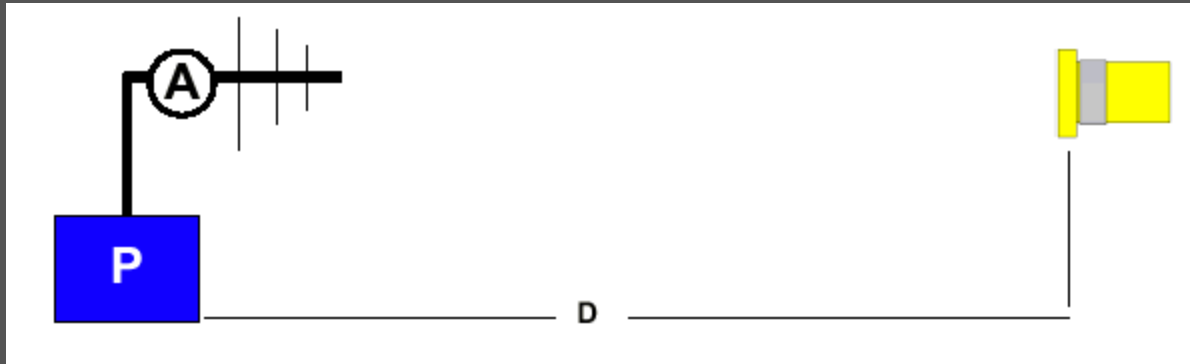

- Current P/N 12525143 thick wall primer's ignition element is not HERO compliant
- Current primer has several features that can lead to critical defects in manufacturing
- Current primer is very labor intensive to build
- Purple lacquer for sealing the flash hole may not be available in the near future

The M125 Thick wall primer has many critical characteristics and is difficult to manufacture



The improved Thick wall primer eliminates most critical characteristics and is easier to manufacture

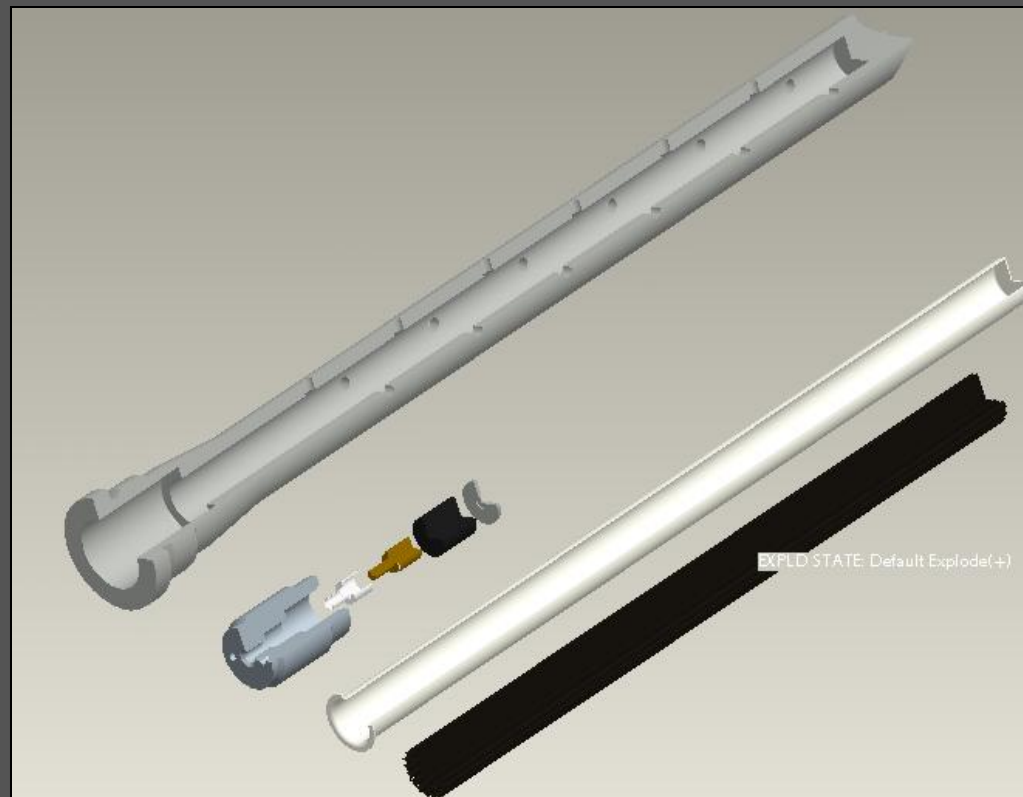

Simple

- Fewer parts
- Reduced labor
- Lower cost for ignition element
- Less to go wrong in manufacturing

Closure Assy. →

Paper Disc →

4 Grains ZPC →

Body →

Base →

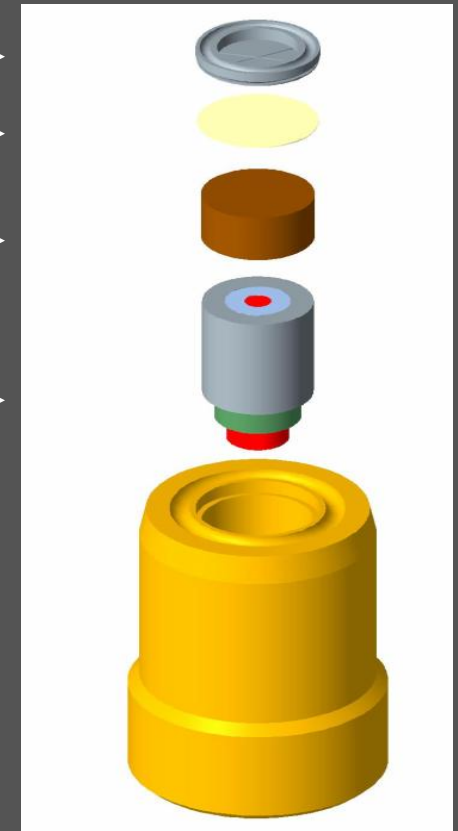

Compatible

- One igniter design for all tank ammunition primers

Primer, Electric (current development)

M129 (future development)

M123A1 (future development)



- **Must meet HERO requirement per MIL-STD 464A**
- **Must meet ESD requirements per MIL-STD 331C, subtest F1**
- **Must meet 120mm International Control Document (ICD) requirements**
- **Must meet fire control on M1A1/A2 Abrams tanks**
 - Must be compatible with Blasting machine
- **No degradation in ballistic performance**
- **Minimize cost increase over the current design**

- Electrode is molded with a glass insulator that is pressed into igniter element base with a welded bridge wire making a more robust design
- Ignition mix is environmentally friendly
- Meets initial HERO requirements
- Meets initial ESD requirements
- Meets vehicle system requirements
- Met cost requirements – currently will be less costly than current design
- Current ballistic requirements
 - Cold condition is up to 5 ms slower than controls

Current primer data

- No fire 210 mA
- All fire 1.25 Amps
- Paper and lacquer seal for primer tube



Initial primer redesign data

- No fire 1.12 Amps
- All fire 2.18 Amps
- Plastic liner seal for primer tube

