



U.S. DEMIL, LLC

SAIC/LEIDOS Prime Contract No. W15QKN-09-9-1001
Subcontractor to SAIC under Purchase Order No. PO10119299



Challenges to the Demil Future

- Permitting - Title IV / MACT Standards for NEW sources
- Treaty Obligations – Landmines & ICMs
- R³ / Sale of Scrap Metals (Certified Safe)
- Funding – Cost of Demilitarization (\$ per ton)

Science of Decineration™ Technology

- The disassociation of molecular bonds in hydrocarbons is a mature industrial technology.
- The industrial embodiment of the Decineration™ process is the use of an externally heated, rotating horizontal tube which essentially duplicates the laboratory model known as "a horizontal flat plate in atmosphere".

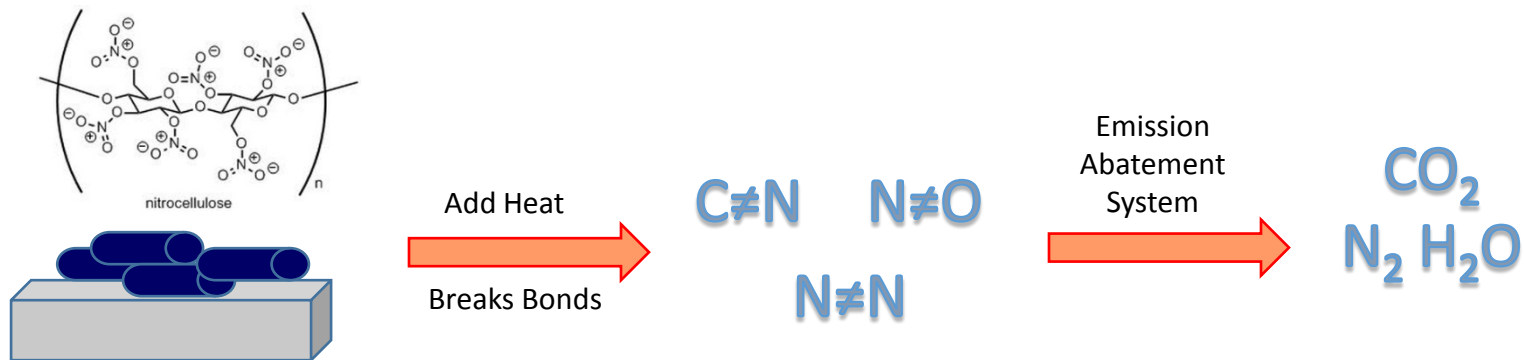

Decineration™ Unit at TEAD

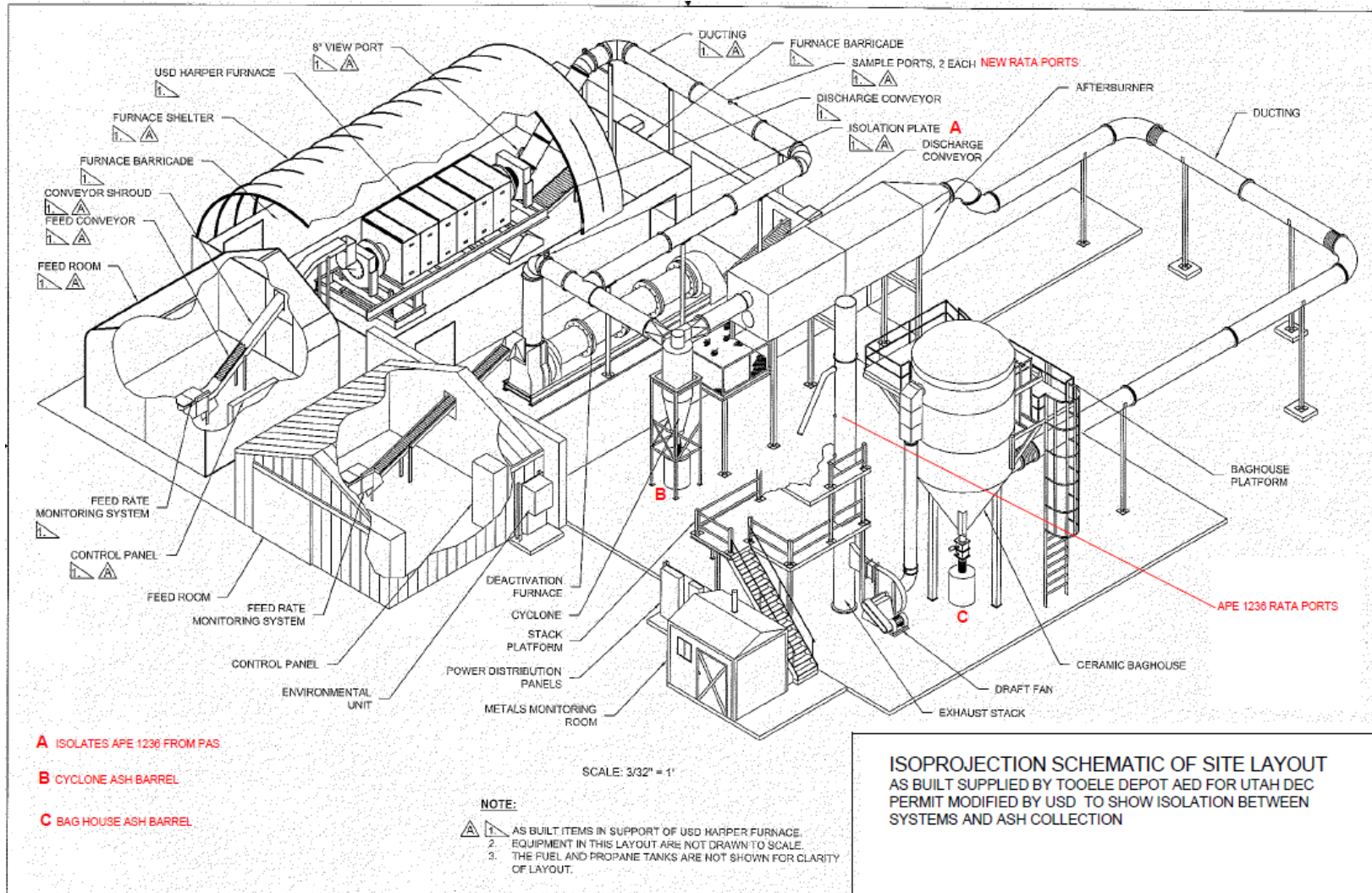

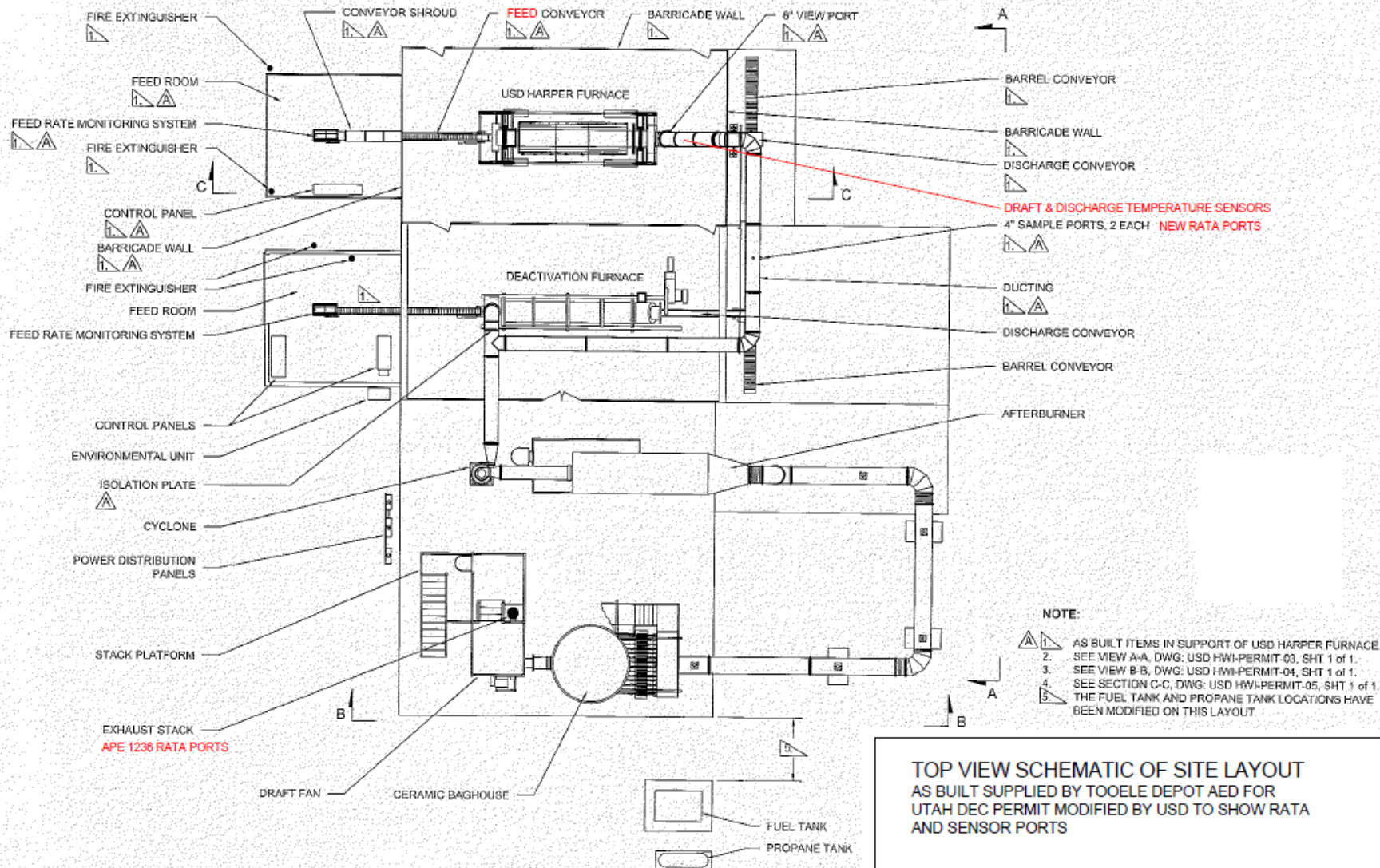

NOTE:

1. AS BUILT ITEMS IN SUPPORT OF USD HARPER FURNACE
 2. SEE VIEW A-A, DWG: USD HWI-PERMIT-03, SHT 1 of 1.
 3. SEE VIEW B-B, DWG: USD HWI-PERMIT-04, SHT 1 of 1.
 4. SEE SECTION C-C, DWG: USD HWI-PERMIT-05, SHT 1 of 1.
- THE FUEL TANK AND PROPANE TANK LOCATIONS HAVE BEEN MODIFIED ON THIS LAYOUT.

**TOP VIEW SCHEMATIC OF SITE LAYOUT
AS BUILT SUPPLIED BY TOOELE DEPOT AED FOR
UTAH DEC PERMIT MODIFIED BY USD TO SHOW RATA
AND SENSOR PORTS**

Material & Data Flow – Emissions System Comparison

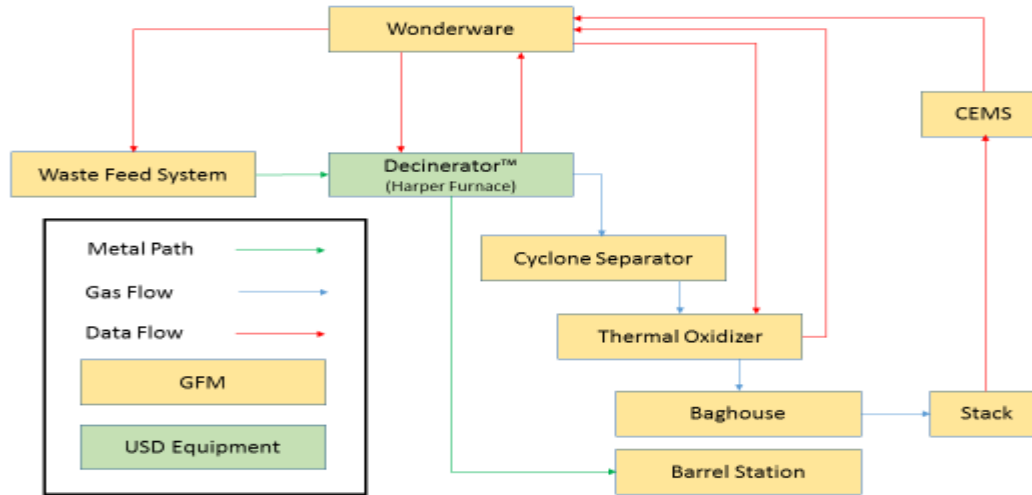

APE1236 Pollution Abatement System

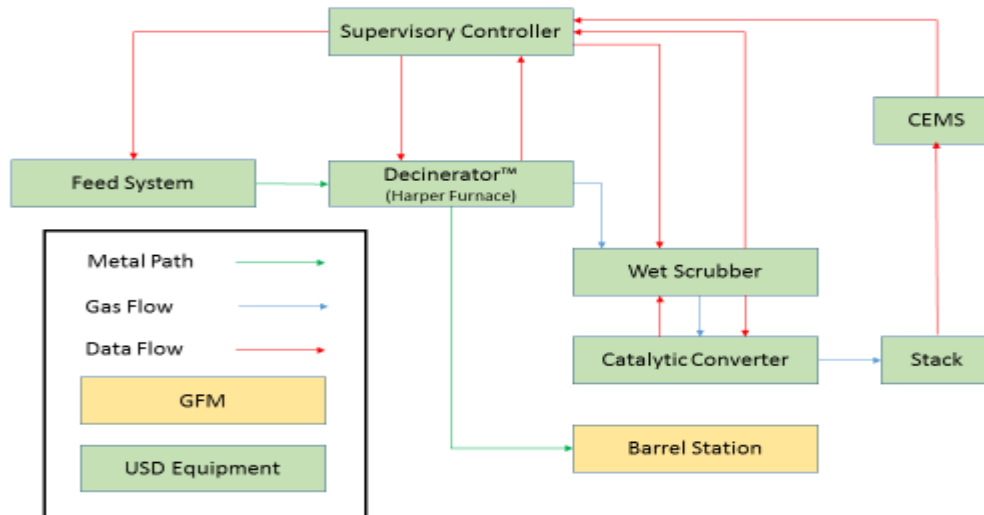

Emissions Abatement System (EAS) Custom Designed for Decineration™ Technology

PROVEN DODICS

- Small Arms Ammunition
- PAD / CAD
- Bulk Explosive (RDX)
- N285 Mechanical Timed Fuze
- K184 Anti-Tank Landmine (cryo-fractured)



Processed 1390-N285 Mechanical Timed Fuze Post Processing



Processed 1390-N285 Mechanical Timed Fuze, cut to validate explosive free

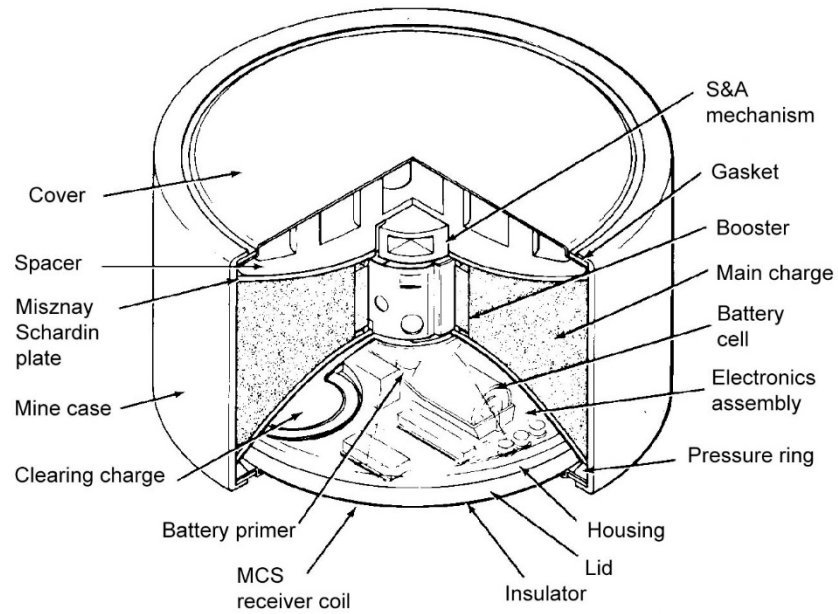

1345-K184 Cryo-fractured Anti-Tank Mine After Processing

- All processed DODICs were examined by QASAS during formulation and proven demilitarized BY FIELD CHEMICAL TEST
- All DODICs were declared “SAFE” for scrap sale following processing to formula
- Potential to become “Certified Safe”



Sample N285

60% of American Metal Market (AMM) Magazine's Consumer Buying Prices, No. 1 Heavy Melt, Chicago

Example:

If AMM No. 1 Heavy Melt = \$375.00 per Gross Ton
Price: \$0.1004 per lb.



Sample A652

36% of COMEX Copper

Example:

If COMEX Copper = \$3.0640 per lb.
Price = \$1.103 per lb.

APE 1236 PAS vs. USD EAS

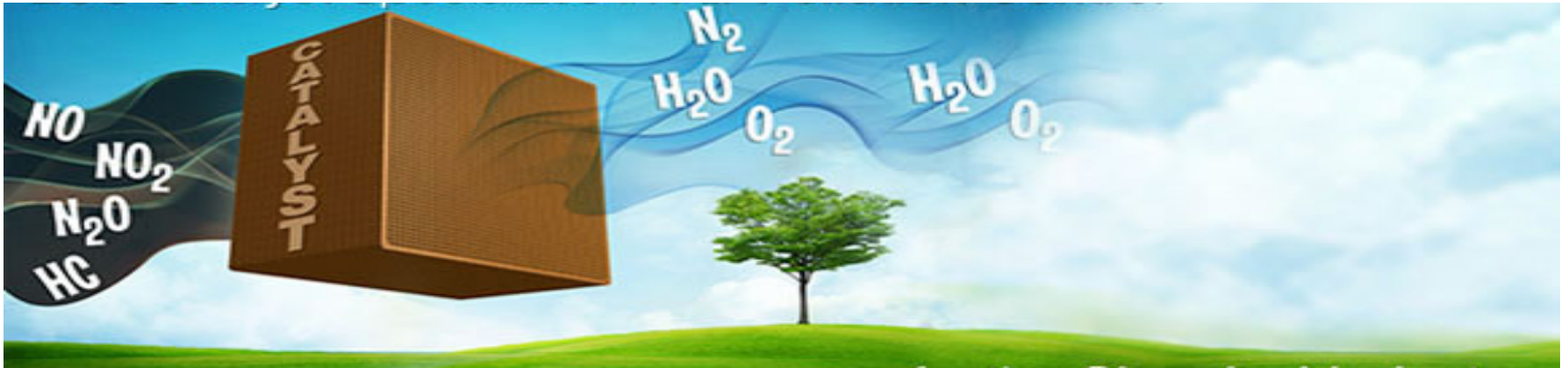

	APE 1236 PAS	Decineration™ EAS
Particulate Capture Efficiency	99.9%	99.9%
Hydrocarbon Destruction Efficiency (SVOC / TOC)	88%	99.9%
Metals Particulate Recovery	NO	YES
Fuel Oil Consumption	YES	NO
Meets MACT Standards for NEW sources	NO	YES

* MACT standards for NEW sources will affect ALL Carbon based systems

State Environmental Permitting Findings

Military Munitions Exemption Rule (MMER)

MMER States

INDIANA
1,000 pph SAA - CAD/PAD

Indiana's Branch Chief - Air Permits, IDEM has indicated process would be considered a "REGISTERED SOURCE".

Relevant Office of Land Management personnel have stated the following

"... we have read Mr. Matt Hale's letter (USEPA) and it reinforces our initial evaluation of your process and the likelihood that a hazardous waste operating permit is not needed."

Non-MMER States

UTAH
1,000 pph SAA - CAD/PAD

State of Utah Department of Environmental Quality (UTDEQ) has reviewed the USD's "Decineration" technology and has determined that while it is not an incineration or hazardous waste treatment process; they would require a Sub Part 'X' permit.

Their expressed expectation is that a standard application followed by a limited duration public hearing period would result in a permit being issued within ninety to one hundred eighty days (90-180) days from application. They foresee no complications that would stall or prohibit permitting of a "Decineration" processing plant.

CO₂ Emissions

- Supreme Court ruling, 29 April 2014, confirmed that EPA has the legal authority to regulate CO₂ as a pollutant.
- Negotiations in Paris for new international treaty limits on CO₂ emissions.
- CO₂ regulatory restrictions will be announced in the coming years, with likely enforcement by State regulators. The Decineration™ System will have a competitive advantage in a carbon constrained environment because of its electrical fuel source.
- This has far-reaching ramifications for any system using carbon-based fuels, which will affect the APE 1236 operation far more than the Decineration™ System; **the APE 1236, is powered by oil (a carbon fuel) whereas the Decinerator™ is run on electricity, which can be provided by zero-carbon, renewable power (hydro, solar, or wind).**

Demilitarization as a Profit Center

3 Technologies at TEAD

	Operation/Production Costs (\$/Ton)		Waste Disposal Cost (\$/Ton of Munitions)	Value of Recovered Materials (\$/Ton of Munitions)	Total Cost of Operation using 21.8 Tons as Basis (\$/Ton)*		Total Profit for 416 Tons **
	PAS	EAS			PAS	EAS	
Decinerator™	\$1,083	\$200	\$7	\$1,027	\$63	(\$820)	\$341,120
Ape 1236	\$8,002	N/A	\$162	\$334	\$7,830	N/A	(\$3,257,280)
Base Hydrolysis	\$12,254	N/A	\$8,626	\$1	\$20,879	N/A	(\$8,685,664)

NOTES:

PAS – Pollution Abatement System designed and used for treatment of APE 1236 emissions

EAS – Emissions Abatement System designed and used for Decineration™ technology exclusive of TEAD technology Comparison Study

* 21.8 tons of munitions were processed by Decineration™ technology for the comparison of this study. APE 1236 is based on one-time G21X tests. Base Hydrolysis costs represent historical data provided by TEAD.

** Profit Comparisons based upon a USD Decinerator™ with EAS and an APE1236 as currently configured 416 tons per year / 208 days of munitions processing (historical TEAD Production APE1236 rate)

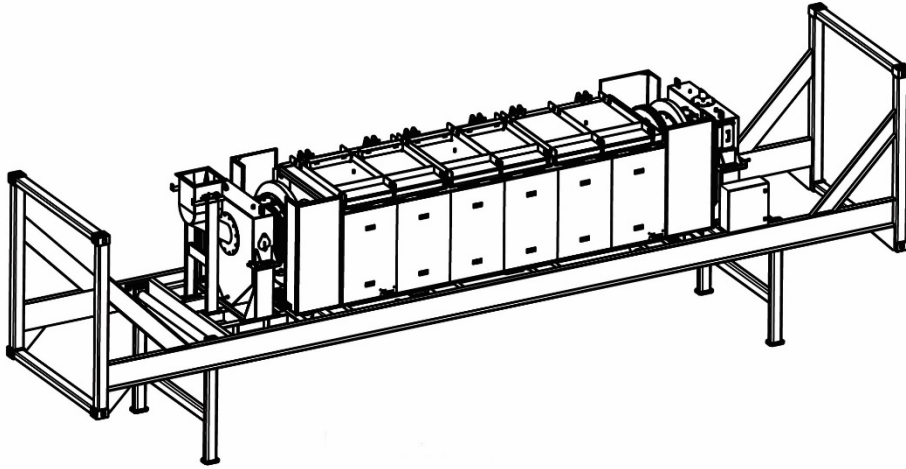

Standard ISO Configuration

Field Deployable

Airlift Capable

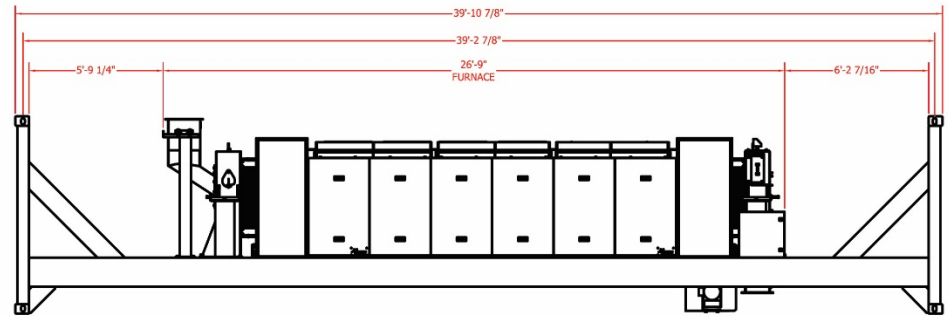

FURNACE PLAN VIEW

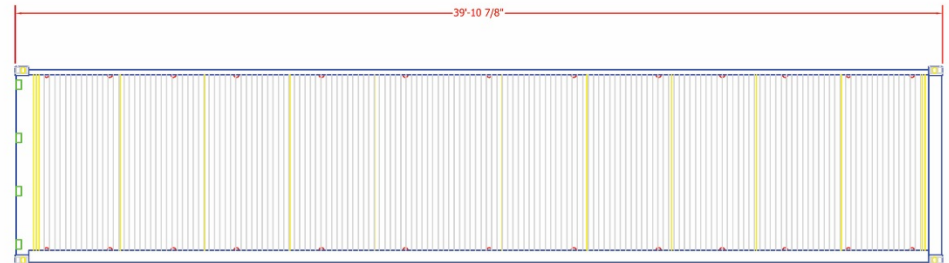

CONTAINER PLAN VIEW



David J. Kautz, PE
U.S. Demil, LLC.
140 Irwin Place
Amherst, NY 14228
U.S.A.
(voice) 716.817.6719
(cell) 716.983.3856
dkautz@usdemil.com