



Dynasafe R&D in Demilitarization

Dynasafe Demil Systems

Gene Wells

Global Demilitarization Symposium 2015-12-08

Mission Statement



Our Vision

Dynasafe protects mankind from threats caused by explosive devices and hazardous materials.

Our Mission

Dynasafe makes the world a safer and a cleaner place.

Dynasafe is committed to providing an integrated and all-encompassing DISPOSAL VALUE CHAIN; from surveying and search, to location, clearance, containment and transport, up to disposal and even to the recycling of explosive devices and hazardous materials.

Dynasafe R&D in demilitarization



- The need for customization
- Evolving applications for Calculations
- R&D tools for fast, reliable and safe product development.
- Conclusions

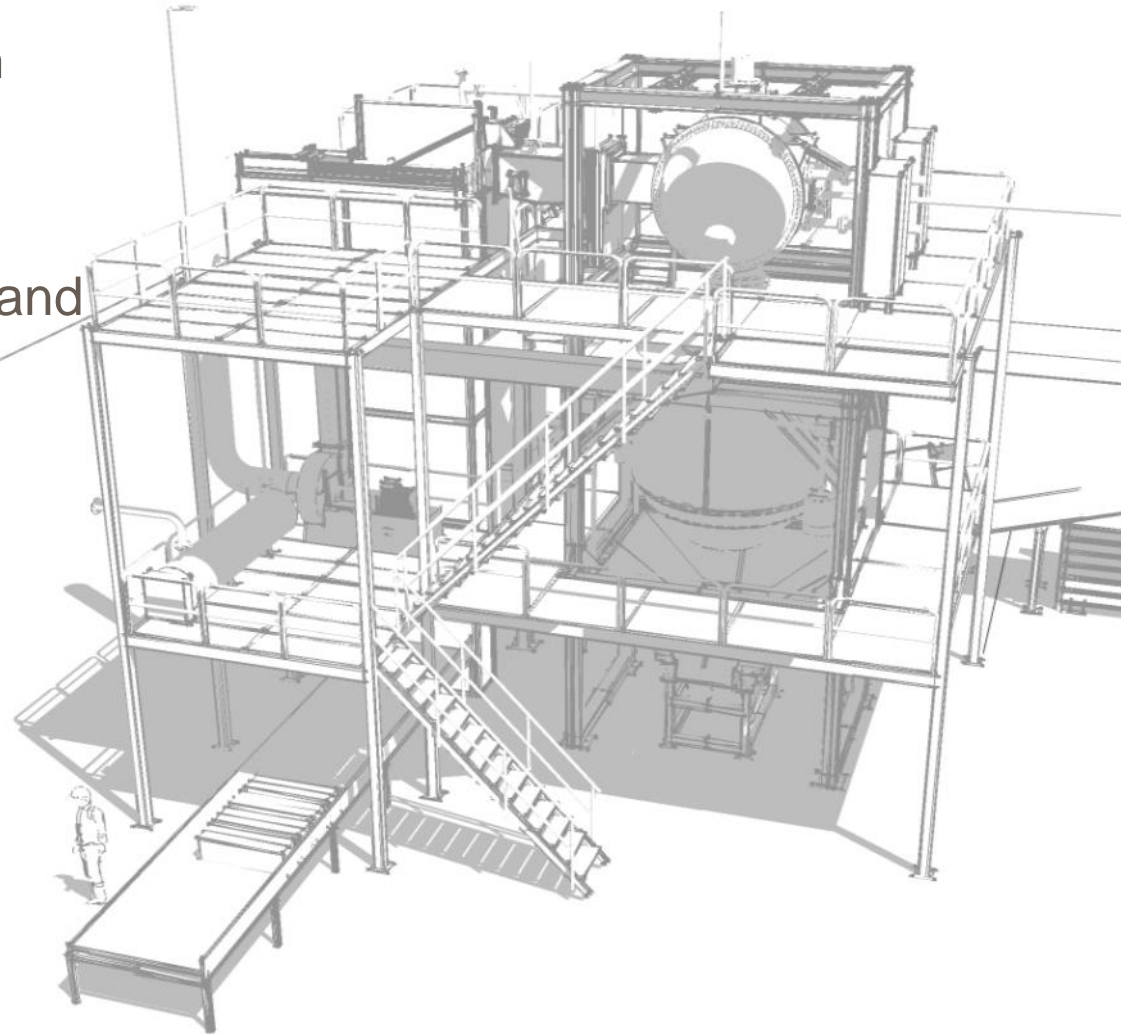

Customer need is the driver for efficient R&D tools



- Customer requirements often look very different in terms of destruction objects, capacity, budget etc.
- To accommodate this need versatile, flexible and modular solutions are necessary.
- It is sometimes advantageous to customize a solution for a better fit and optimize to specific requirements.
- The Dynasafe R&D toolbox:
 - quickly work out new solutions, concepts, layouts etc.
 - rapidly and accurately determine strength and durability of critical system components or assemblies (Loading Systems, Detonation Chambers, Building Structures etc.)
 - analyze waste stream process flows, mass balances, etc.

The Dynasafe Calculation Toolbox



- Reliable FEM calculations are important to understand strength and durability.
- Ultimately, this transfers to safety at destruction sites.
- Dynasafe has 25 years of experience in developing safe and productive solutions for both protection and demilitarization systems using process knowledge gained and an evolving calculation methodology.
- The process begins with the understanding of calculation fidelity with respect to protection systems. They are exposed to the most extreme loads in terms of shock and fragmentation wear.
- This fidelity can then be used to accurately determine strength and durability of demilitarization systems.

Using Protection systems as the basis: The DynaSEALR X12

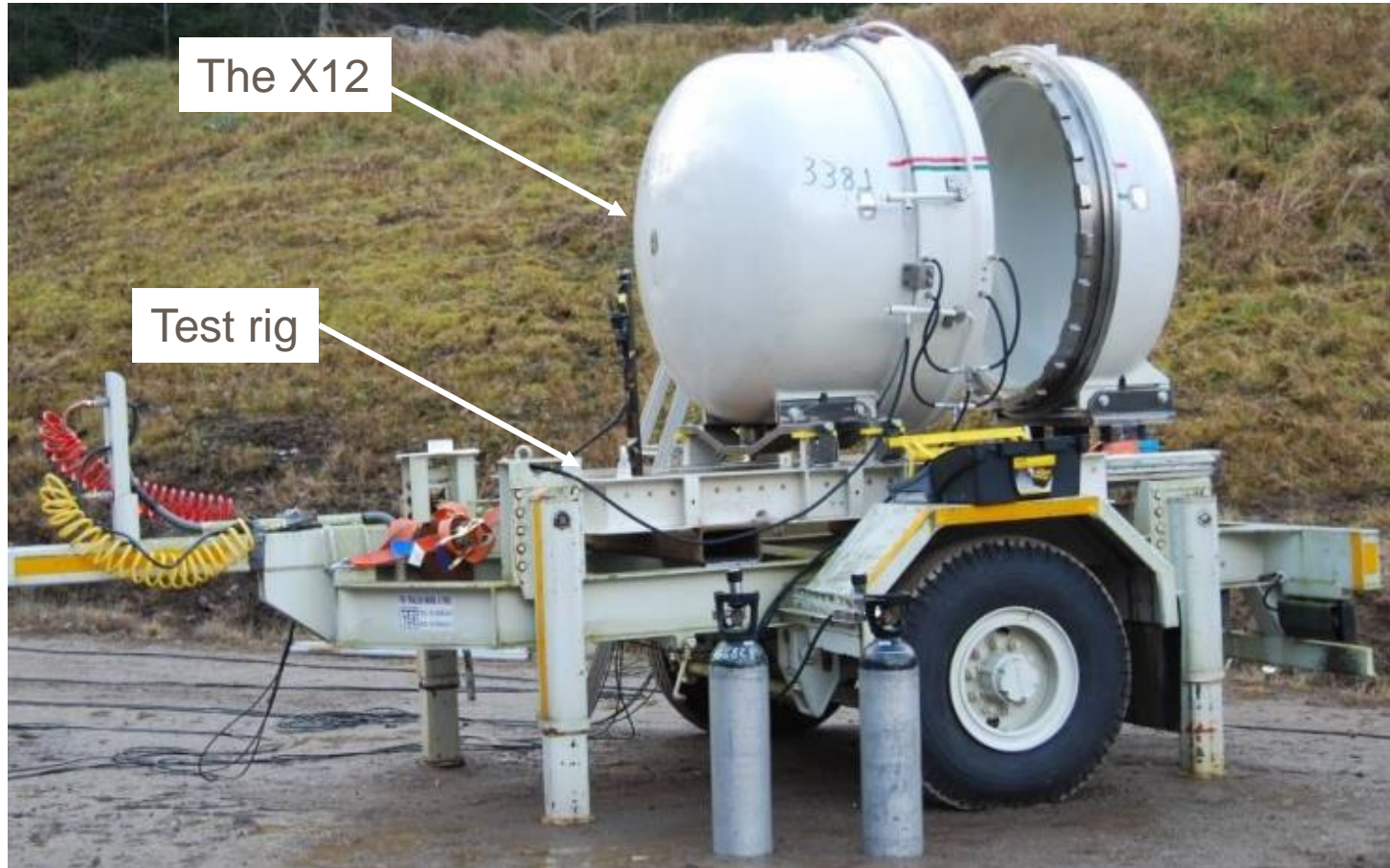

FE-model of the X12

The most relevant load carrying parts

L=1500 mm, D=1300 mm, T=30 mm, W=2800 kg

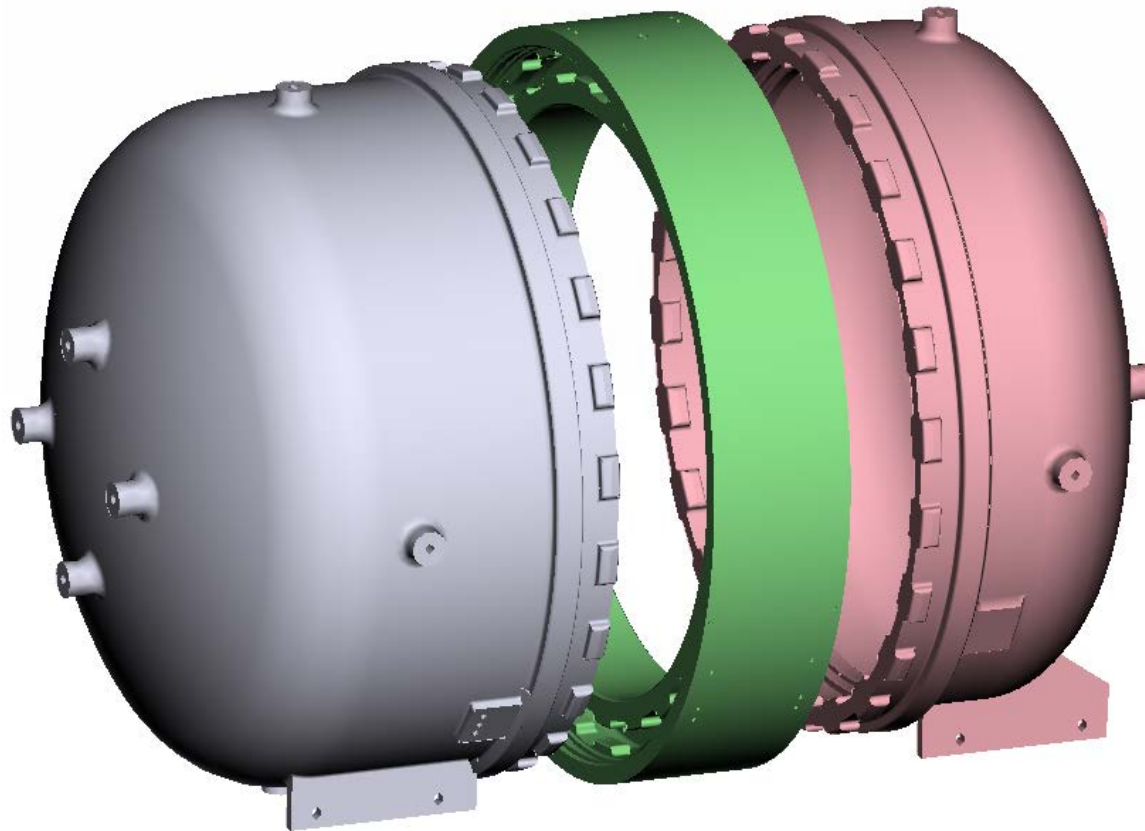

Vessel

Locking ring

Cover

FE-model cont'd.

Simplify and mesh MAP a 15° section of the Locking Ring Teeth

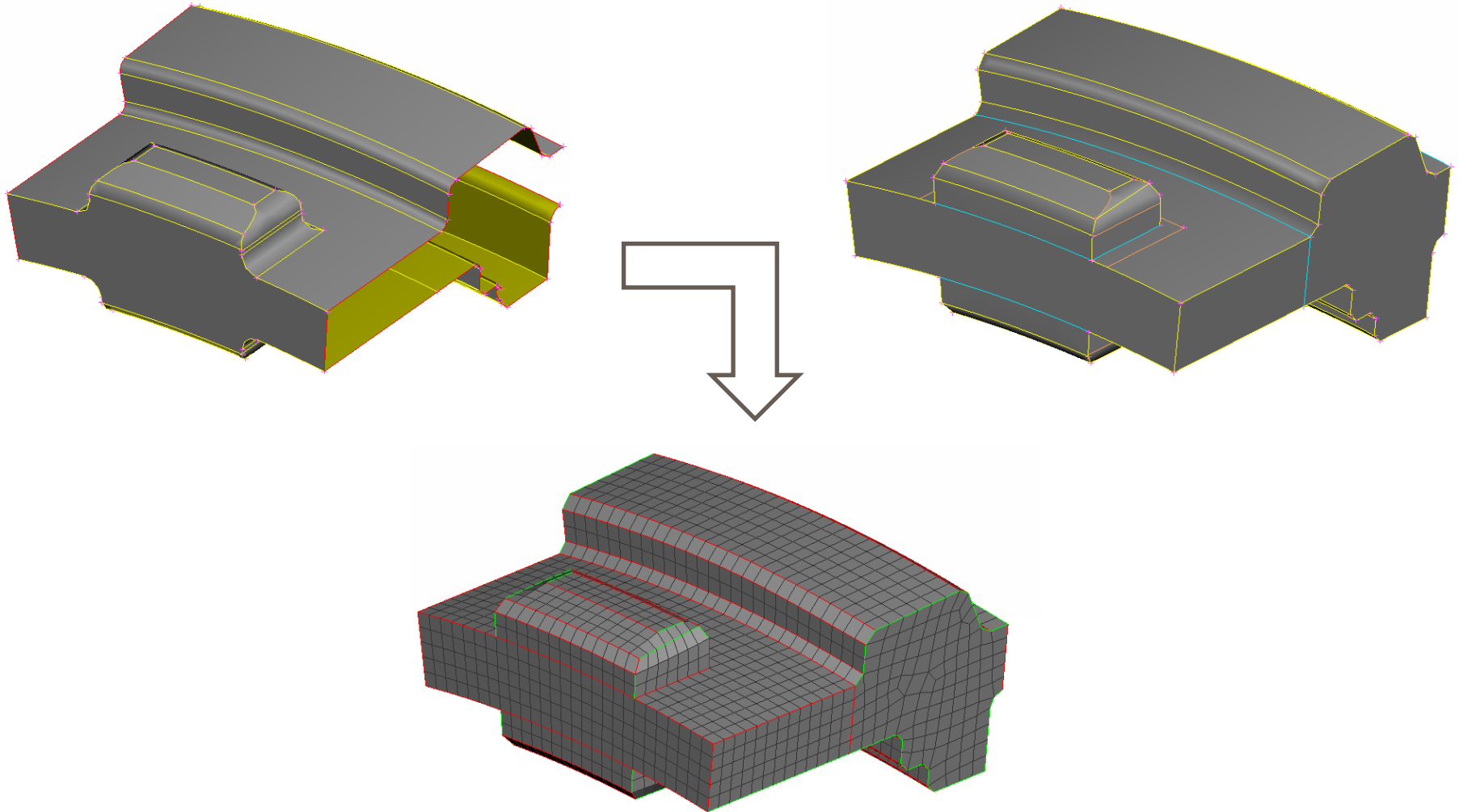

FE-model cont'd

Cut away view of the meshed locking mechanism

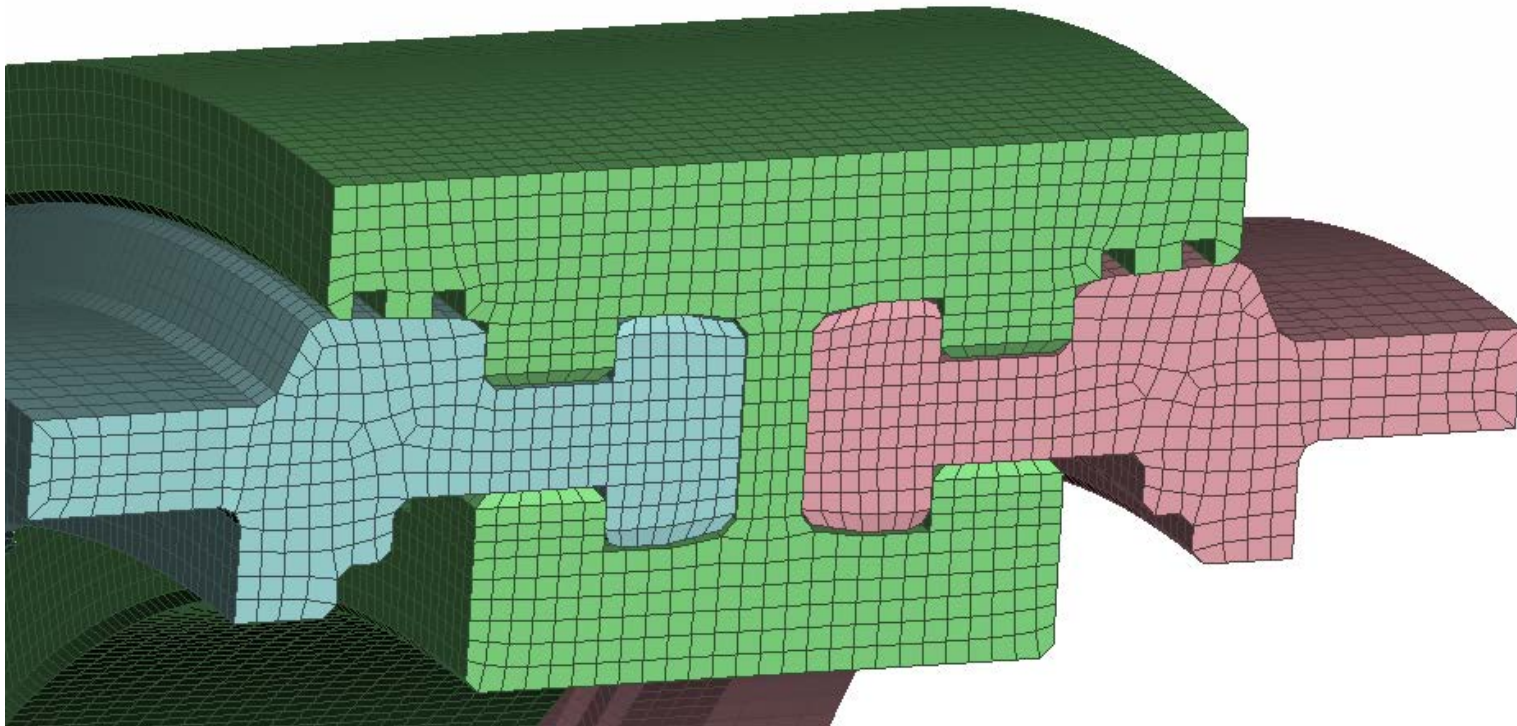

FE-model cont'd

The complete model with attachments. The model consists of 800,000 volume elements with 99.6 % hexas and 0.4 % pentas

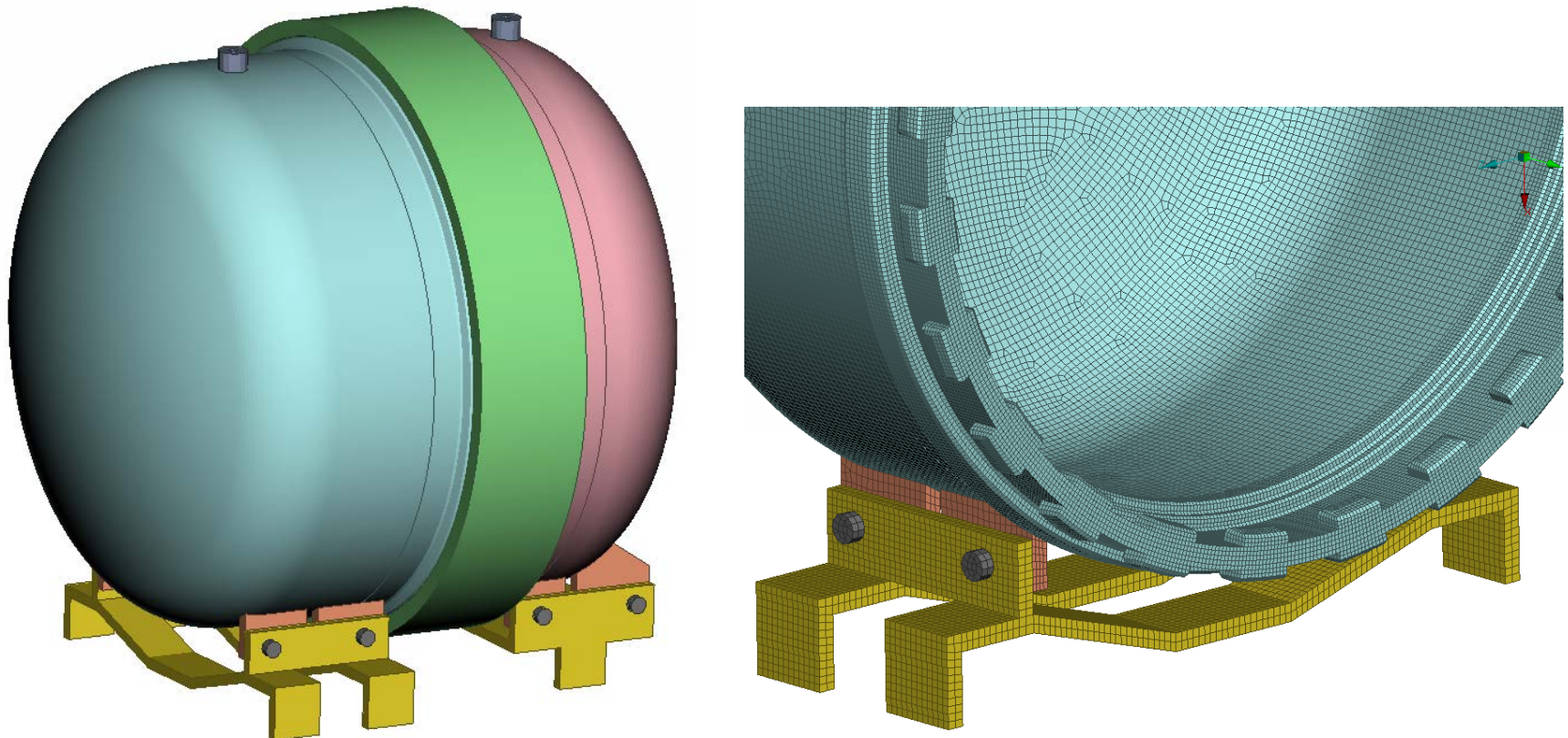

Simulation setup

Spherical charge of 8.0 kg TNT equivalent in the center

Fixed boundary conditions at the bottom feet

High strength steel with yield strength 900-1000 MPa

4 simulated strain gauges

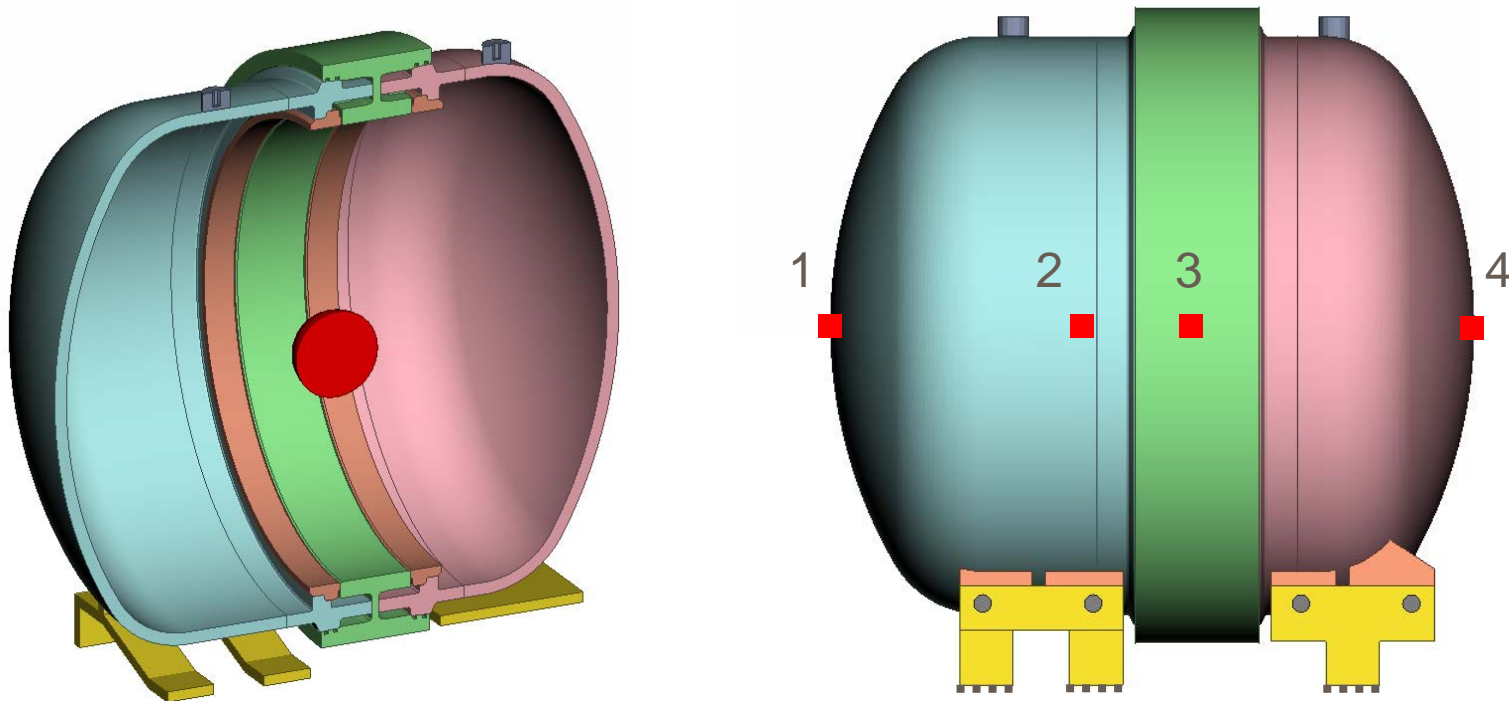

Blast load technique, method 1

Axisymmetric mapping to 3D

The explosive blast load is done in a separate axisymmetric fluid Multi Material Arbitrary Lagrangian Eulerian (MMALE) simulation.

The pressure is recorded on the fixed boundary (red line) and a script is used to map the blast load to a 3D structure simulation. This runs approximately 3 hours on 16 processors.

Suitable for axisymmetric chambers (which is very typical)

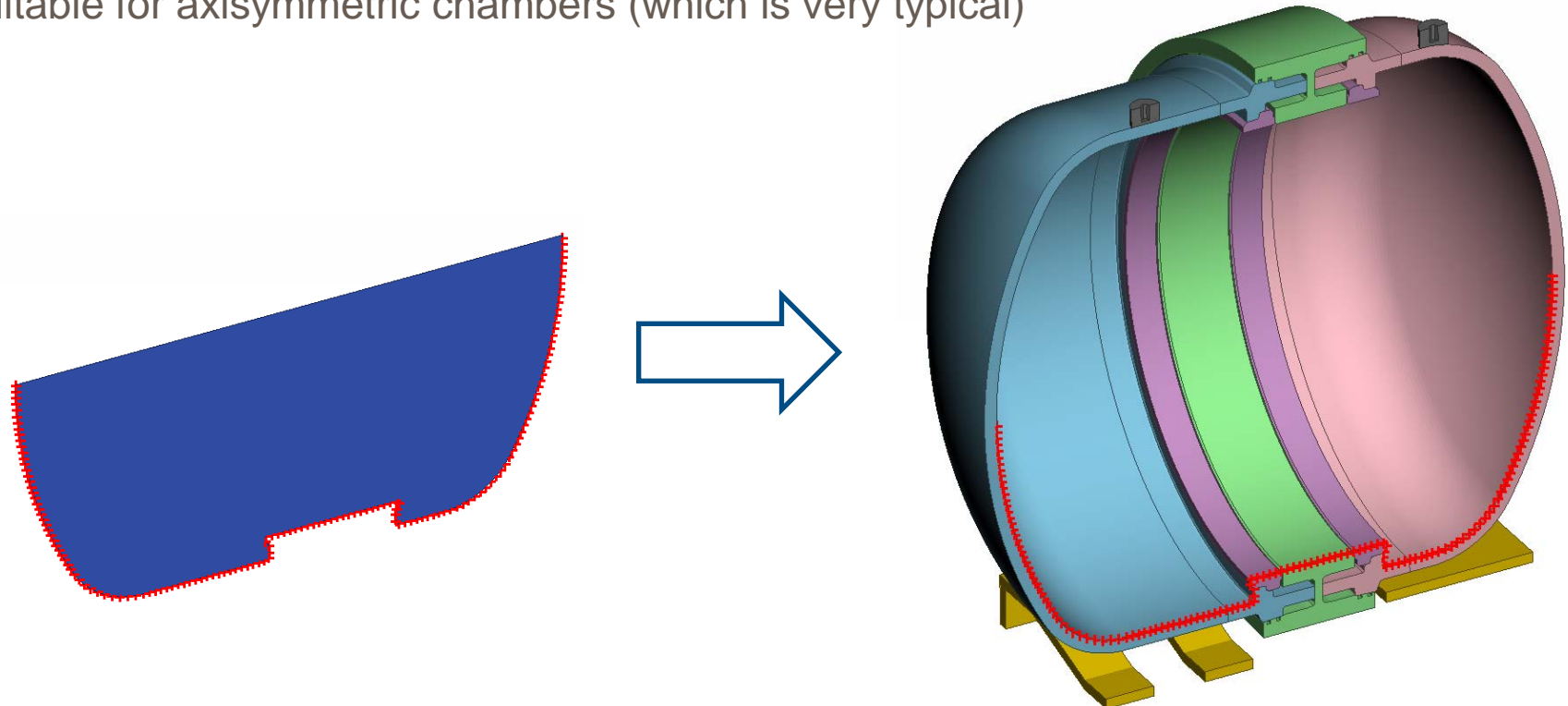

Blast load technique, alternative method

Fluid-structure coupling in 3D

The explosive blast load is done directly in the structure simulation using 3D MMALE with a fluid-structure coupling.

24 hours on 16 processors. The CPU time is significantly reduced by using a half model due to symmetry or remove the fluid after 5-10 ms.

This technique can be employed with any geometry.

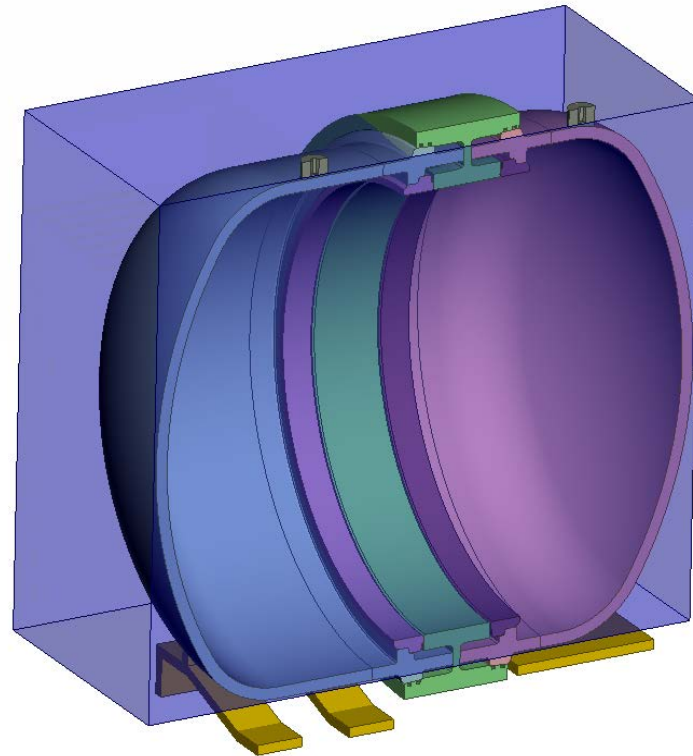

Results from a CFD view

Axisymmetric blast load simulation, 8kg TNT, first 2 ms

Pressure fringe scale 0-0.02 GPa (0-200 bar)

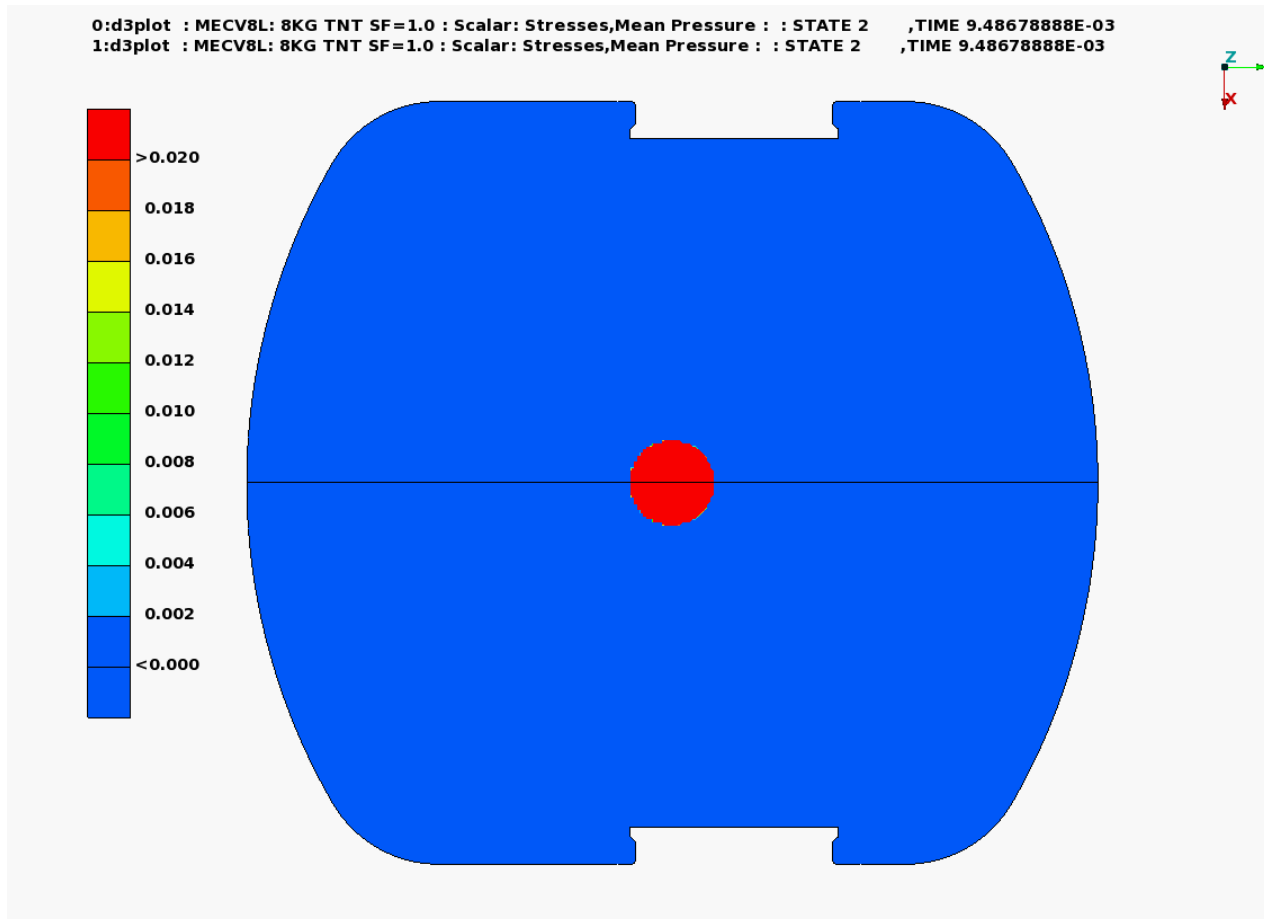

Results from structural dynamics view

Structure simulation, first 10 ms

The vessel and cover ends are moving 5-10 mm. Unscaled displacements in the video.

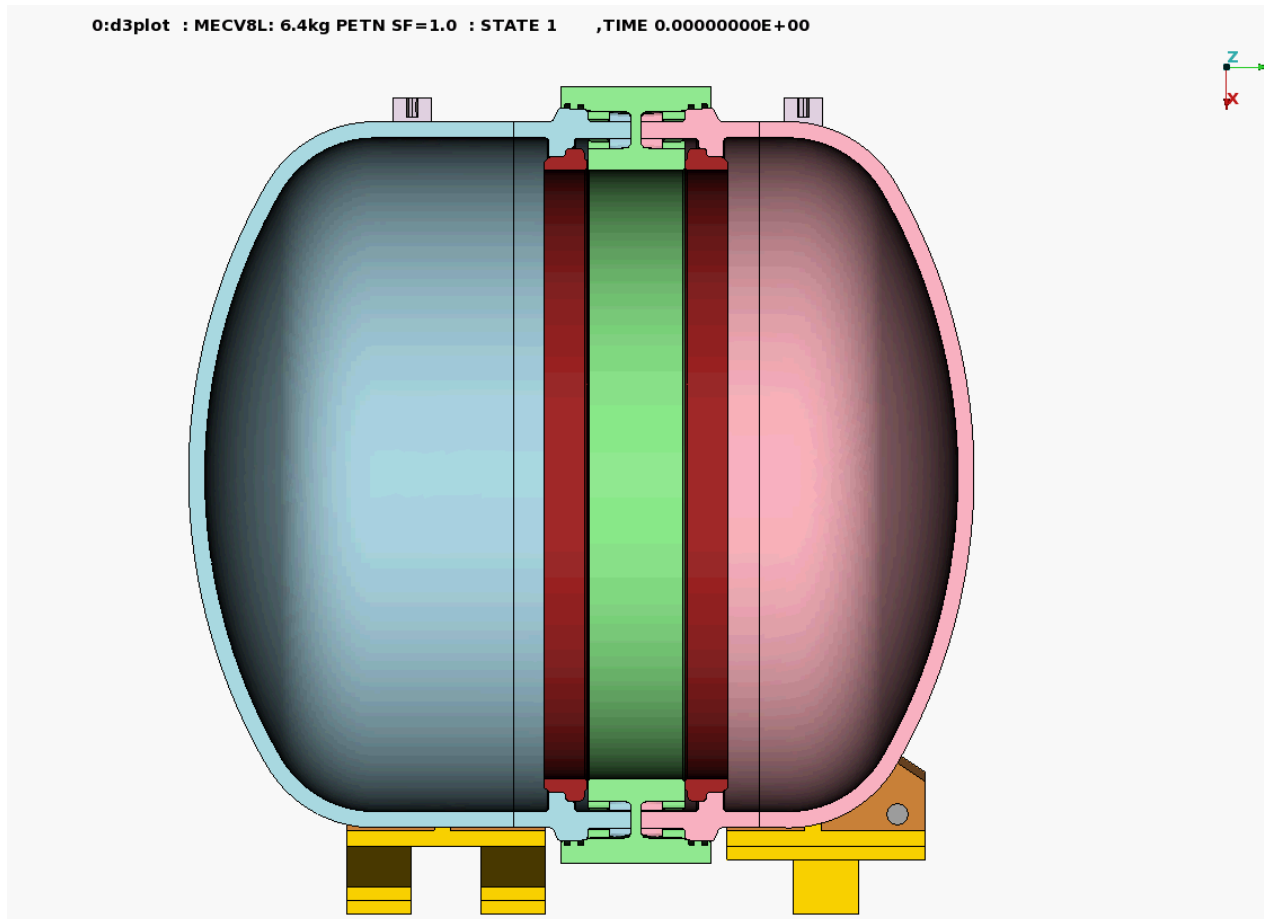

Results from structural dynamics, cont'd

Structure simulation, first 10 ms

The displacement is increased 10 times

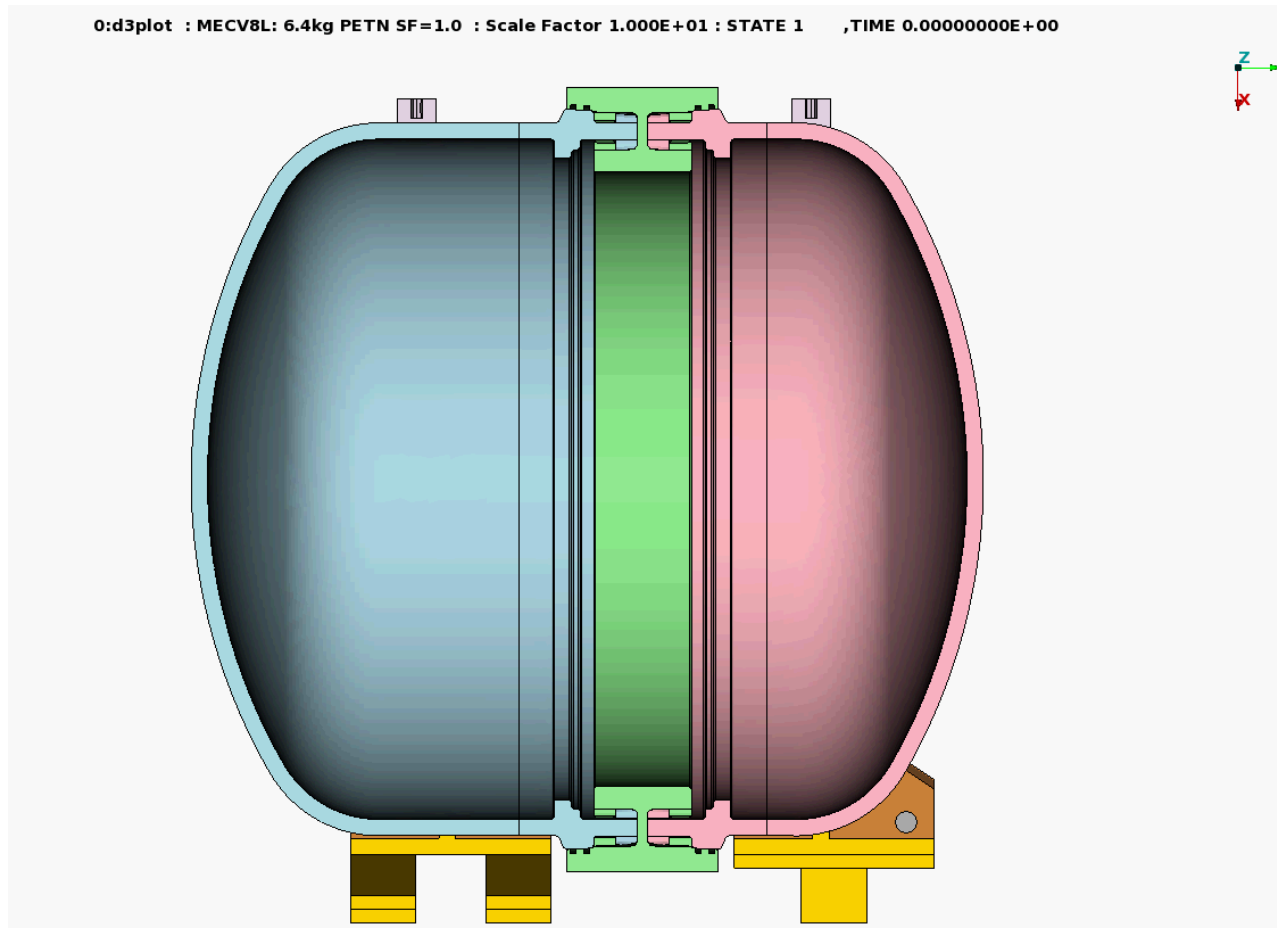

Results comparison, method 1 & 2

Strain curves at the vessel end (gauge 1)

Peak values $\approx 0.6\%$

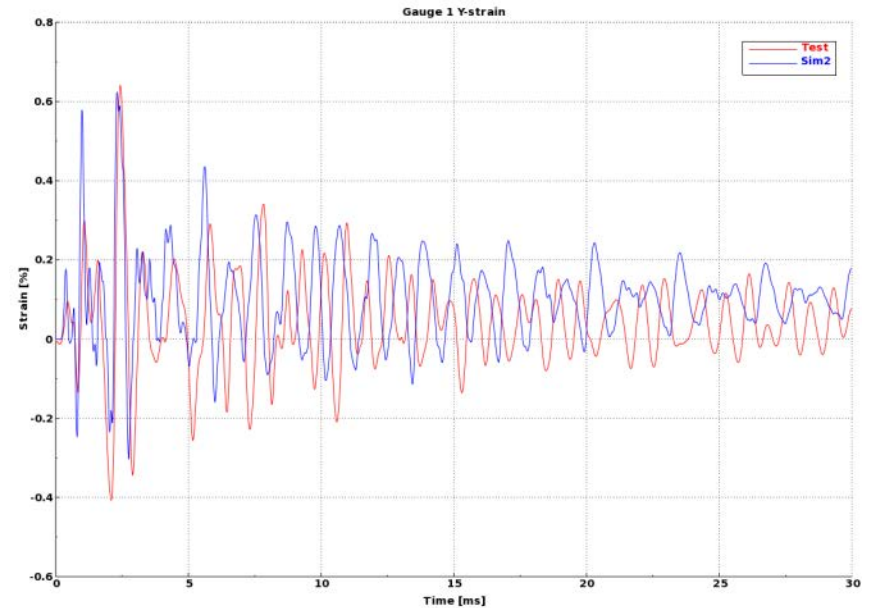
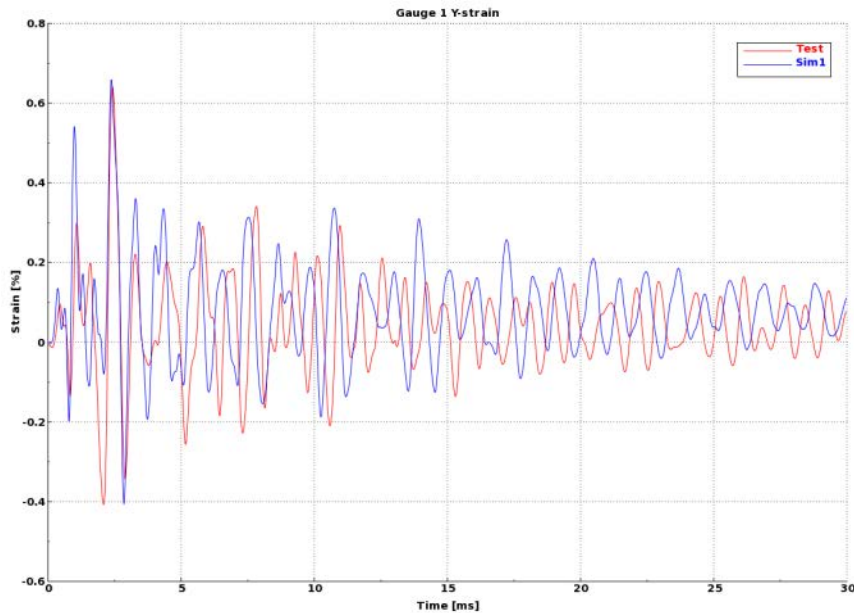

Axisymmetric mapped to 3D

Fluid-structure coupling in 3D

Test curves in red
Simulated curves in blue

RESULTS

Strain curves at the locking ring (3)

Peak values $\approx 0.1\%$

Test
Sim

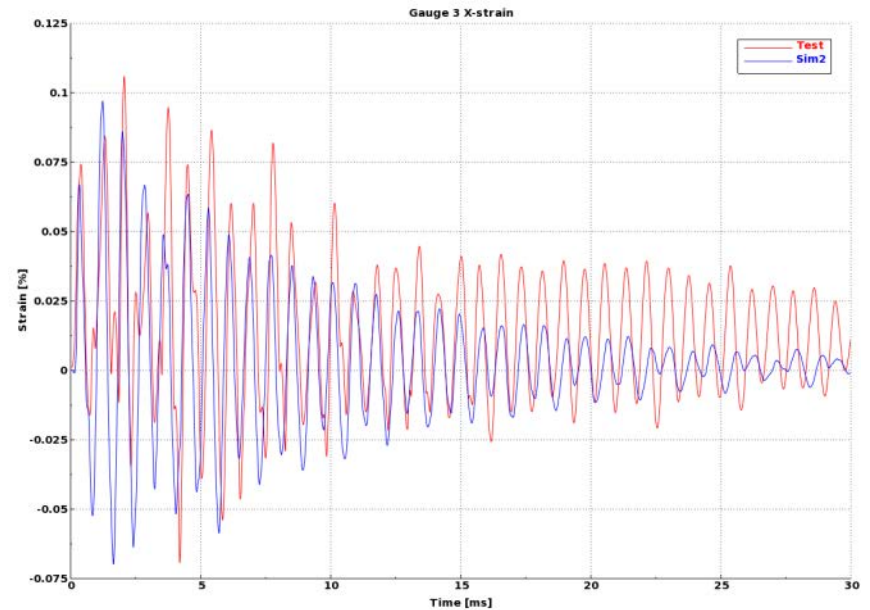
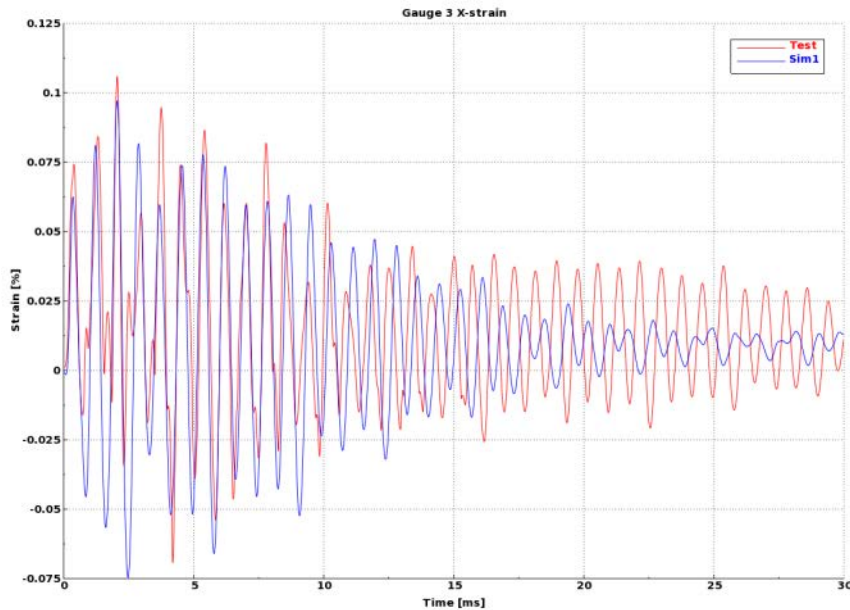

Axisymmetric mapped to 3D

Fluid-structure coupling in 3D

Conclusion from FE-simulations

The simulation and the measured effects are well inline with each other.



Fragment damage calculations

- Tool for determining fragment damage has been developed.
- Multiple layers can be defined and the prediction accuracy is very high.

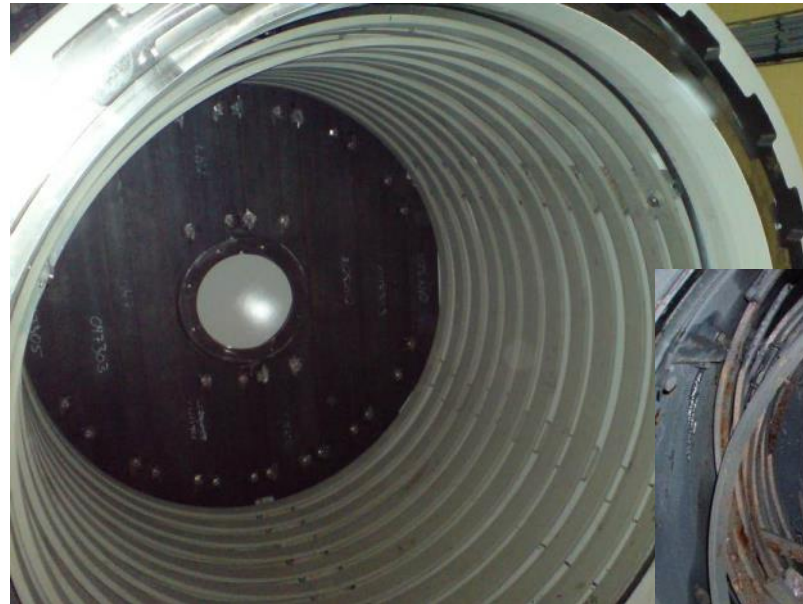
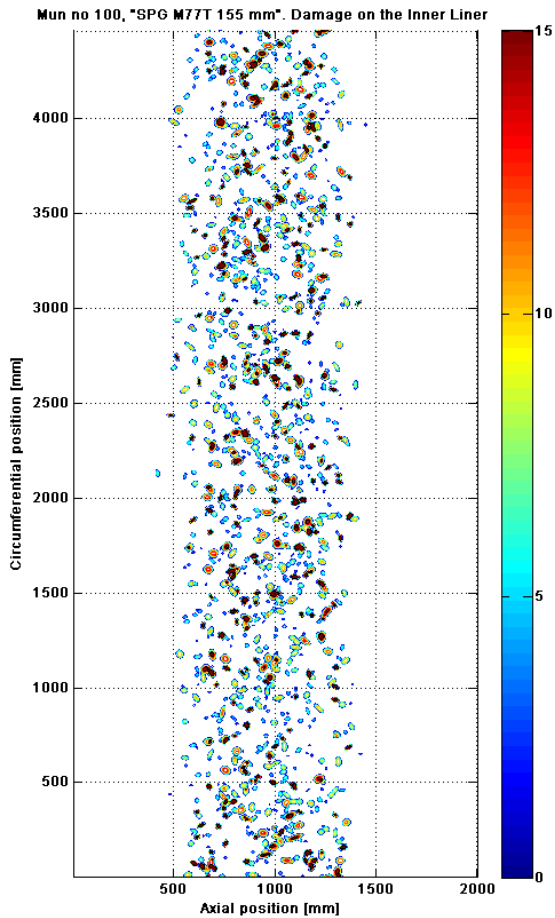

The tools developed for predicting the effects of a blast on a Protection System Chamber are then applied to the cold Detonation Chambers or adapted to the hot Detonation Chambers used in demilitarization

R&D tool: Fatigue

1. CFD simulation with blast data for specific explosives is used to create the load.
2. The dynamic response will show the stresses and strain experienced by the vessel. Highly stressed ROI are mesh-refined to capture the correct.
3. Fatigue are calculated for all ROI according to a selected standard.

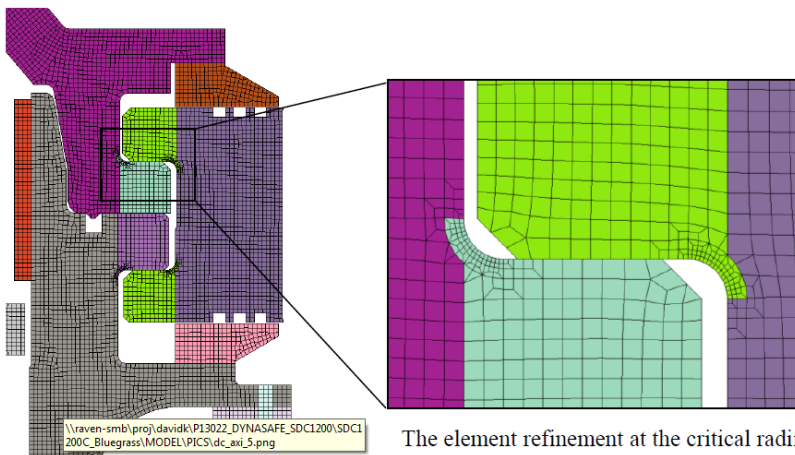

The element refinement at the critical radii

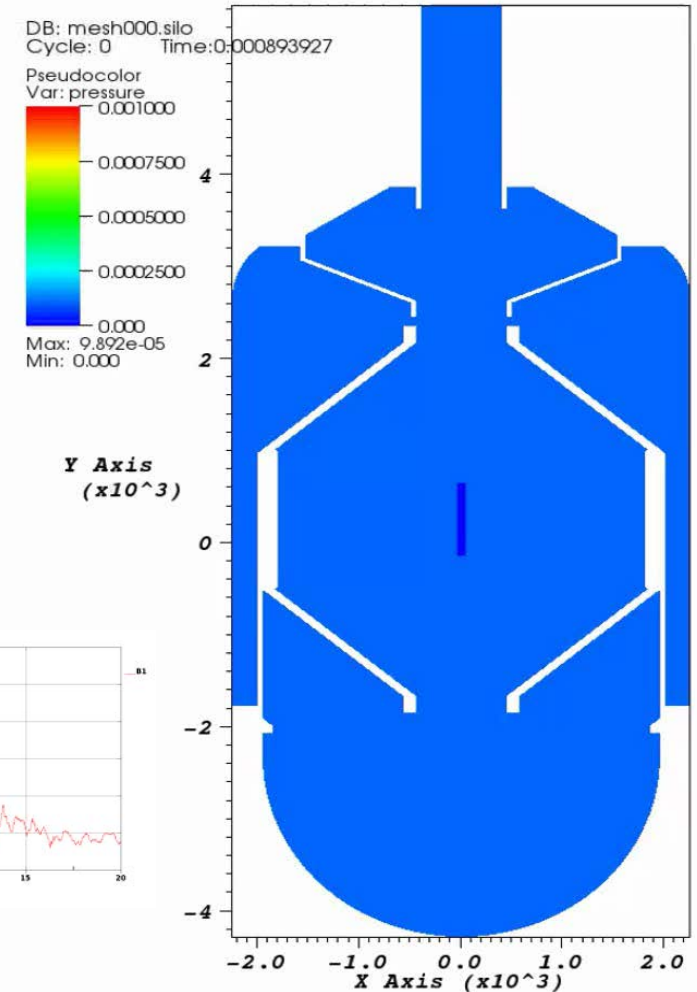
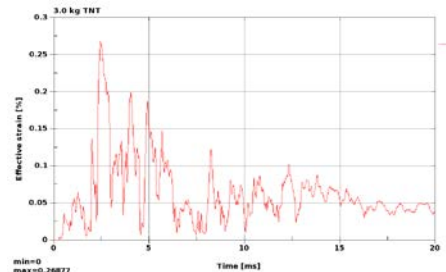

FEM-simulations for strength and durability

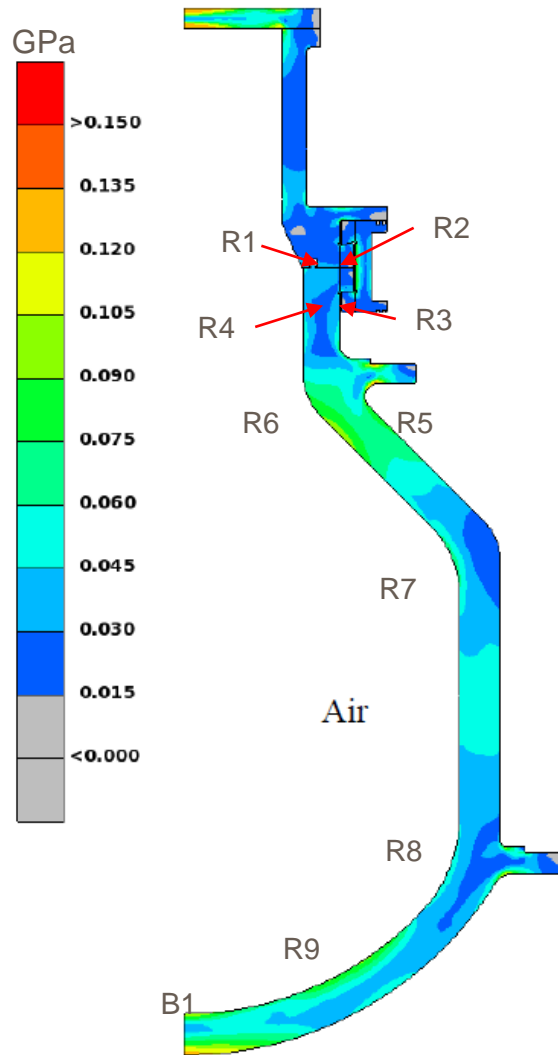

Evaluations of stress, strain and fatigue life. R1-R9, B1 are evaluation points.

Table of max effective stress [MPa] / strain [%]

Area	Air
R1	0.14
R2	0.18
R3	0.20
R4	0.18
R5	0.15
R6	104
R7	74
R8	54
R9	95
B1	128

Estimated fatigue life [detonations]

Area	Air
R1	154 350
R2	10 286
R3	5 508
R4	15 941
R5	15 093
R6	>10 ⁶
R7	>10 ⁸
R8	>10 ⁸
R9	>10 ⁶
B1	376 160

Comparison of predicted vs. actual wear in an operational SDC1200

Predictions

Wear contour

Contour plot on unfolded cylinder

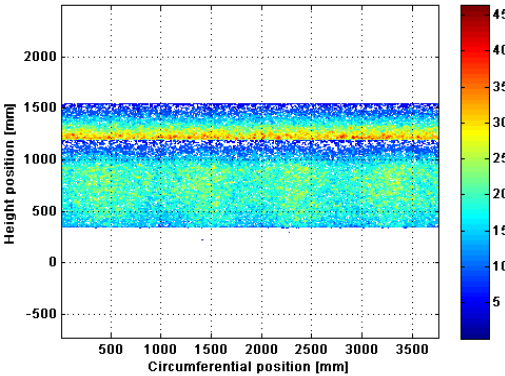

Wear profile along height

Average wear (x-axis) at different heights (y-axis)

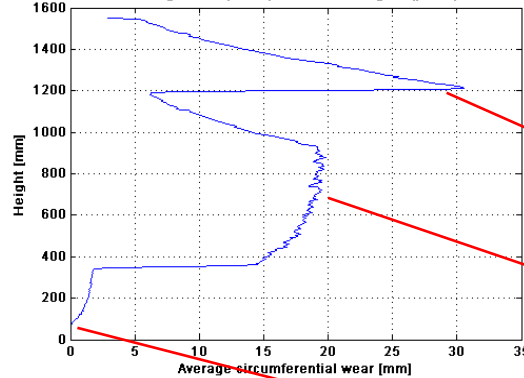

Actual wear

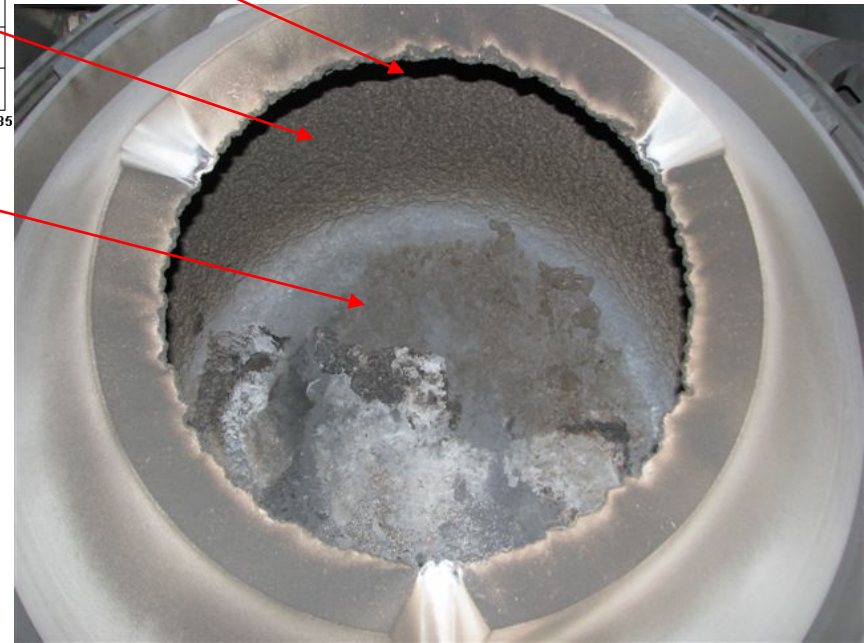

Wear distribution

Wear depth distribution

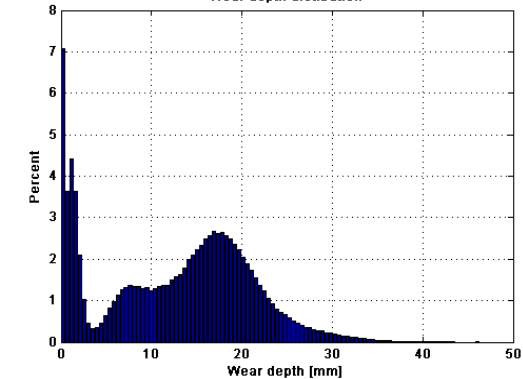

3D representation

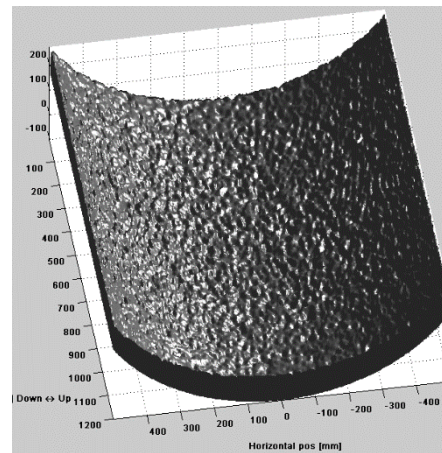

Laser scanning, for accurate wear measurements



Wear along length of DC

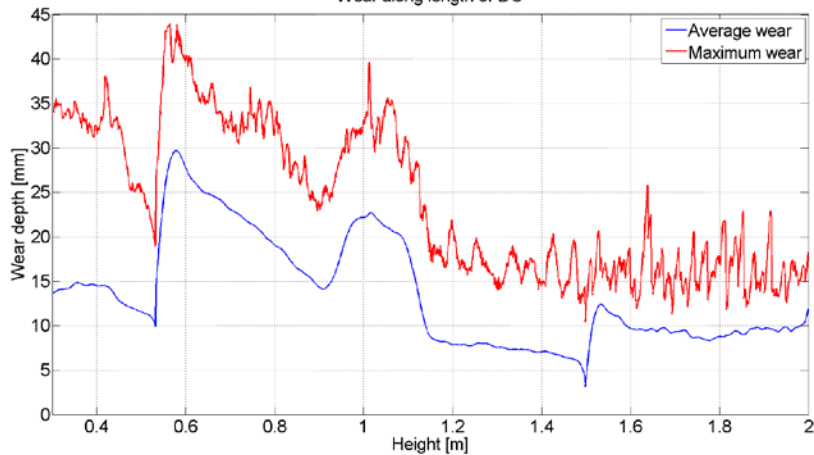

Normalized histogram of estimated wear depth

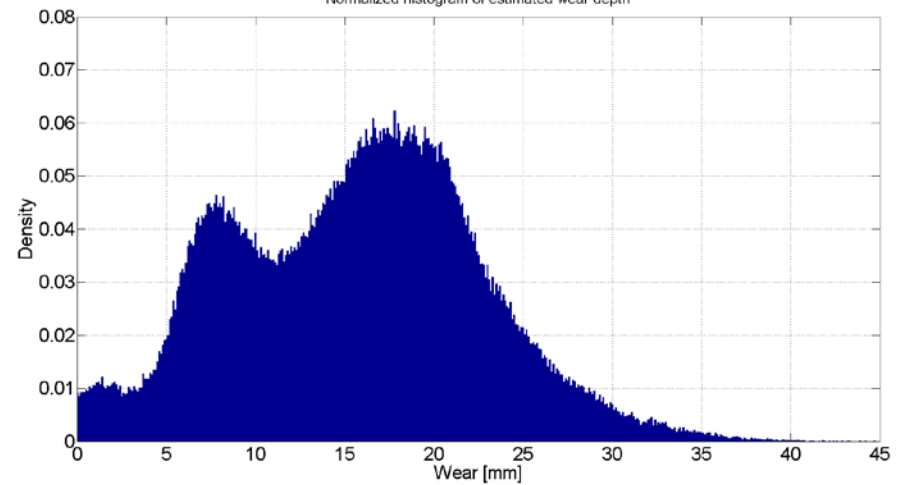

Another useful tool: Process analysis

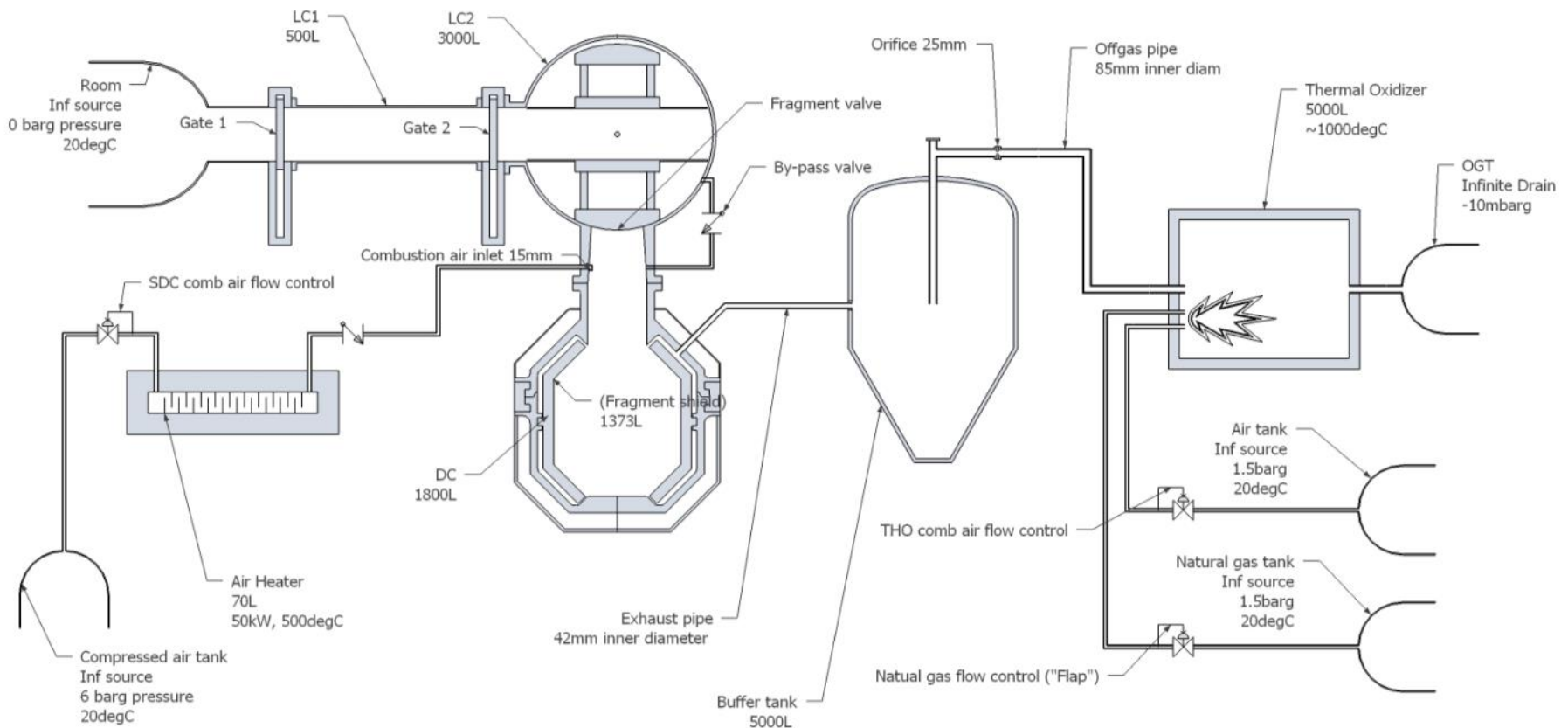

- In-house developed program during 10 years. A multiphysics simulation tool that combines:
 - gas composition, thermophysics, thermodynamics
 - chemical reactions, thermal decomposition, condensation/evaporation
 - gas/liquid/solid flows,
 - structural heating and cooling

Process analysis tool, cont'd

Temperature in DC and BT when feeding M67 rocket motor Overpressure in DC, BT and LC2 when feeding M67 rocket motor

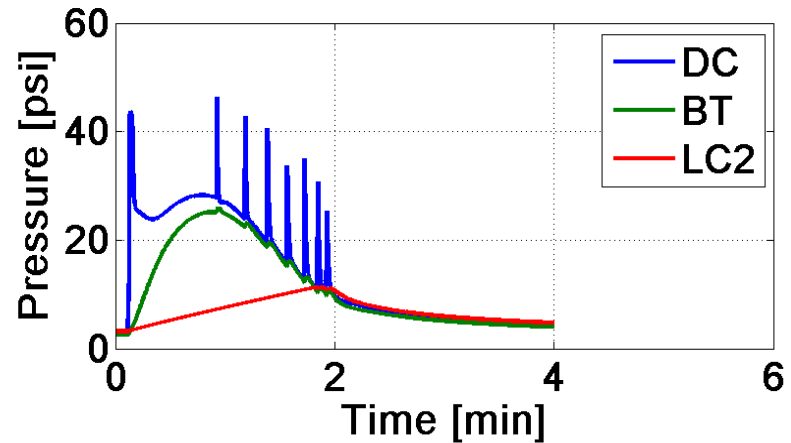
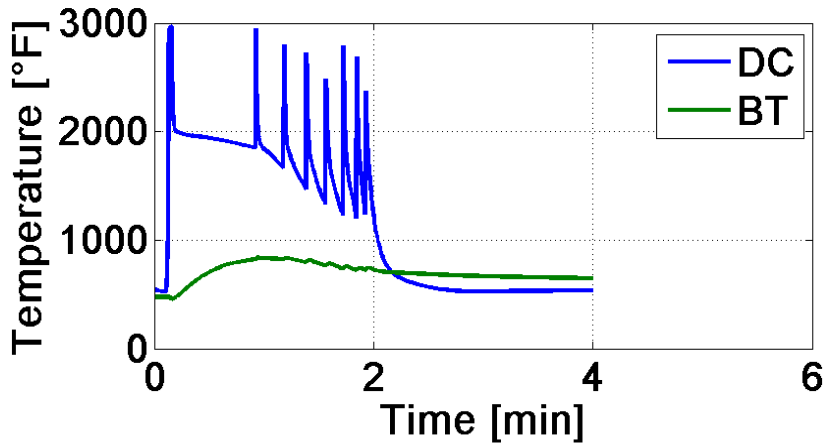

Gas concentrations in DC when feeding M67 rocket motor

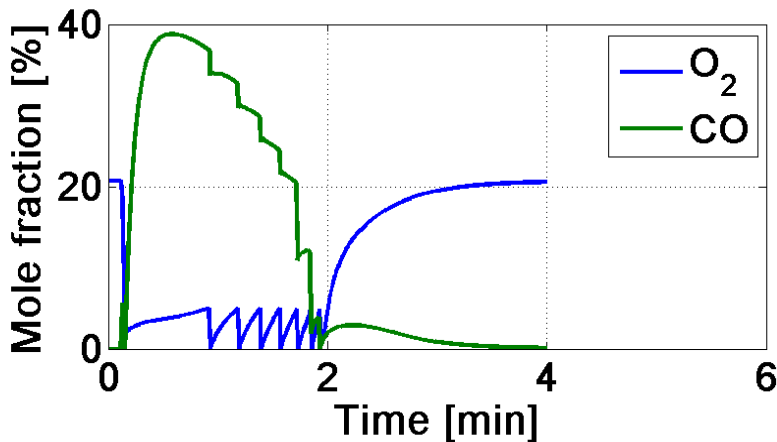

Gas concentrations in BT when feeding M67 rocket motor

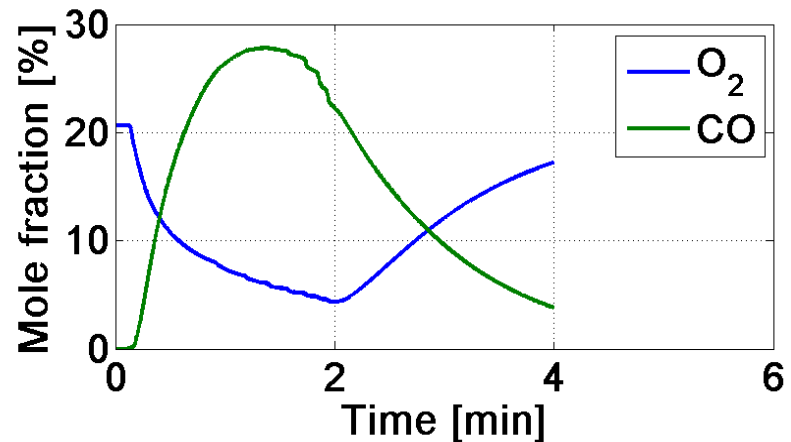

Process analysis tool, cont'd

Temperature in THO when feeding M67 rocket motor

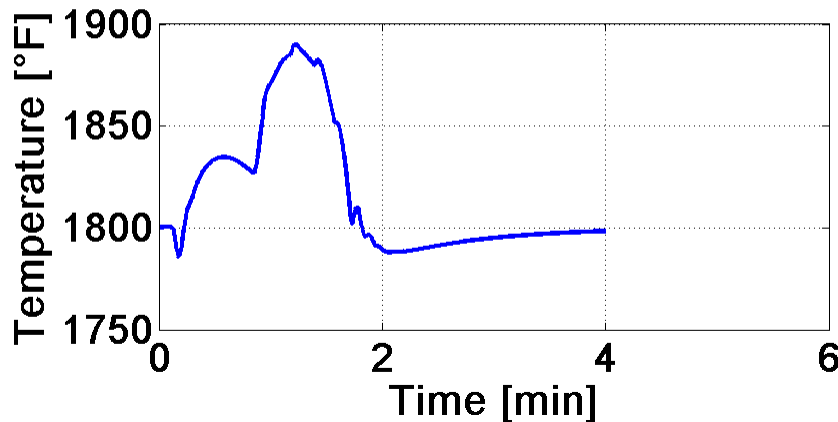

Pressure in THO when feeding M67 rocket motor

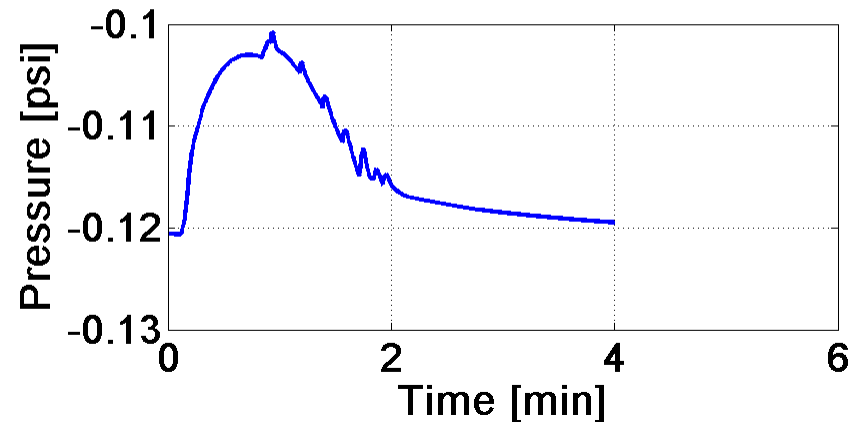

O₂ concentration in THO when feeding M67 rocket motor

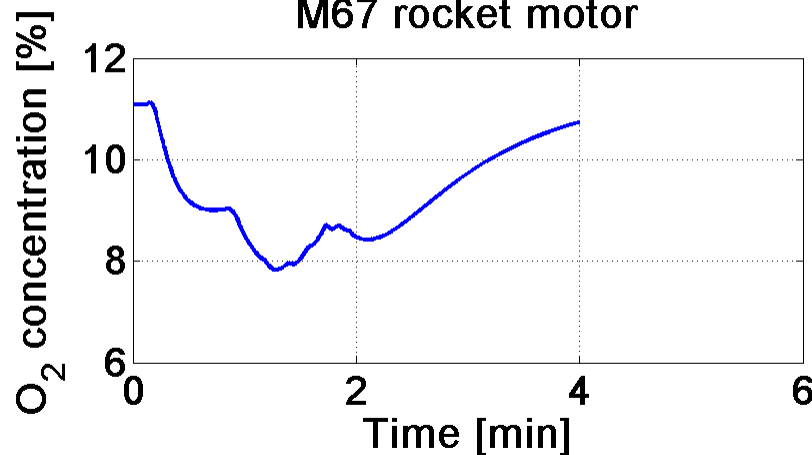

Retention time in THO when feeding M67 rocket motor

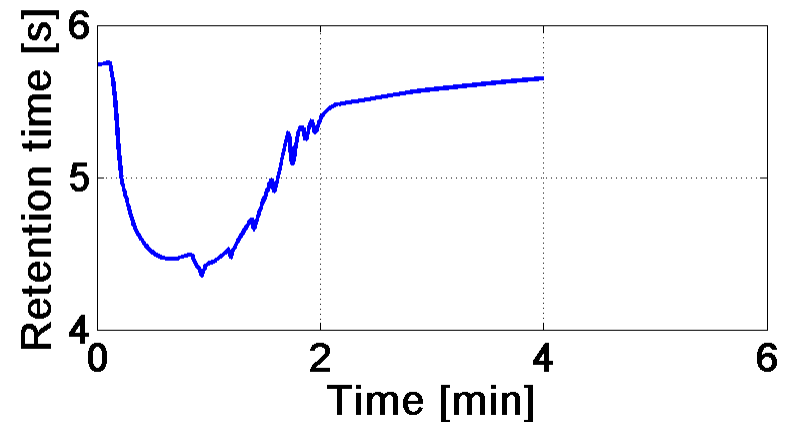

Mass and energy balance tool



Detonation Chamber is normally coupled with an Off Gas treatment (OGT) system that is suitable for the Customer's needs.

Dynasafe designs OGT Systems in-house

Dynasafe has developed a Microsoft Excel based Mass and Energy balance tool for designing the process.

Mass and energy balance tool, cont'd.

Inputs

Define Process
Feed composition
Process parameters

Background calculations

Reaction stoichiometry
Removal efficiencies
Mass balance
Energy balance

Outputs

Stream flows, composition
Pressure, Temperature
Utilities requirements

Typical OGT

General process flow, Chemical Weapons

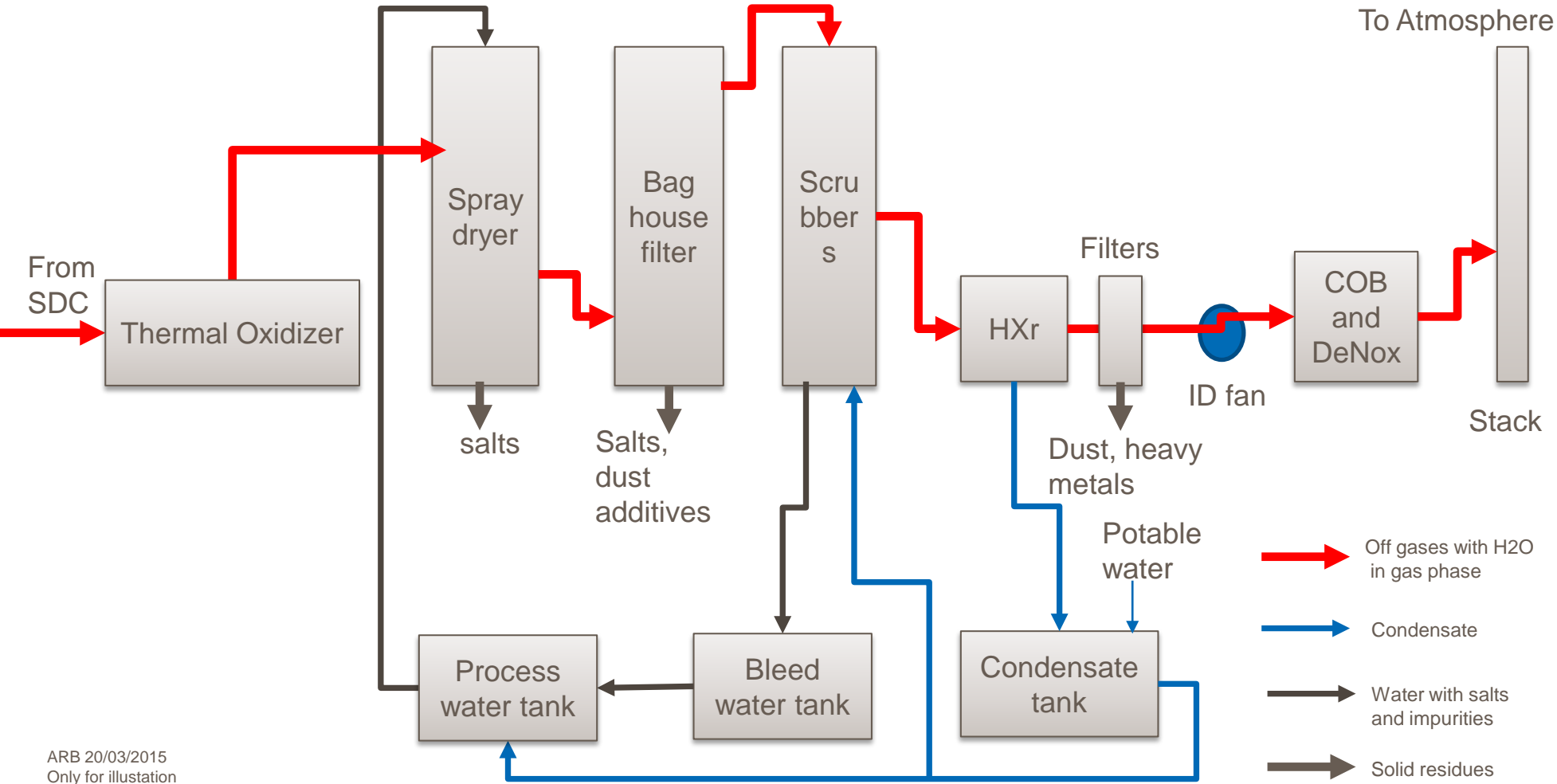

ARB 20/03/2015
Only for illustration

PFD -10

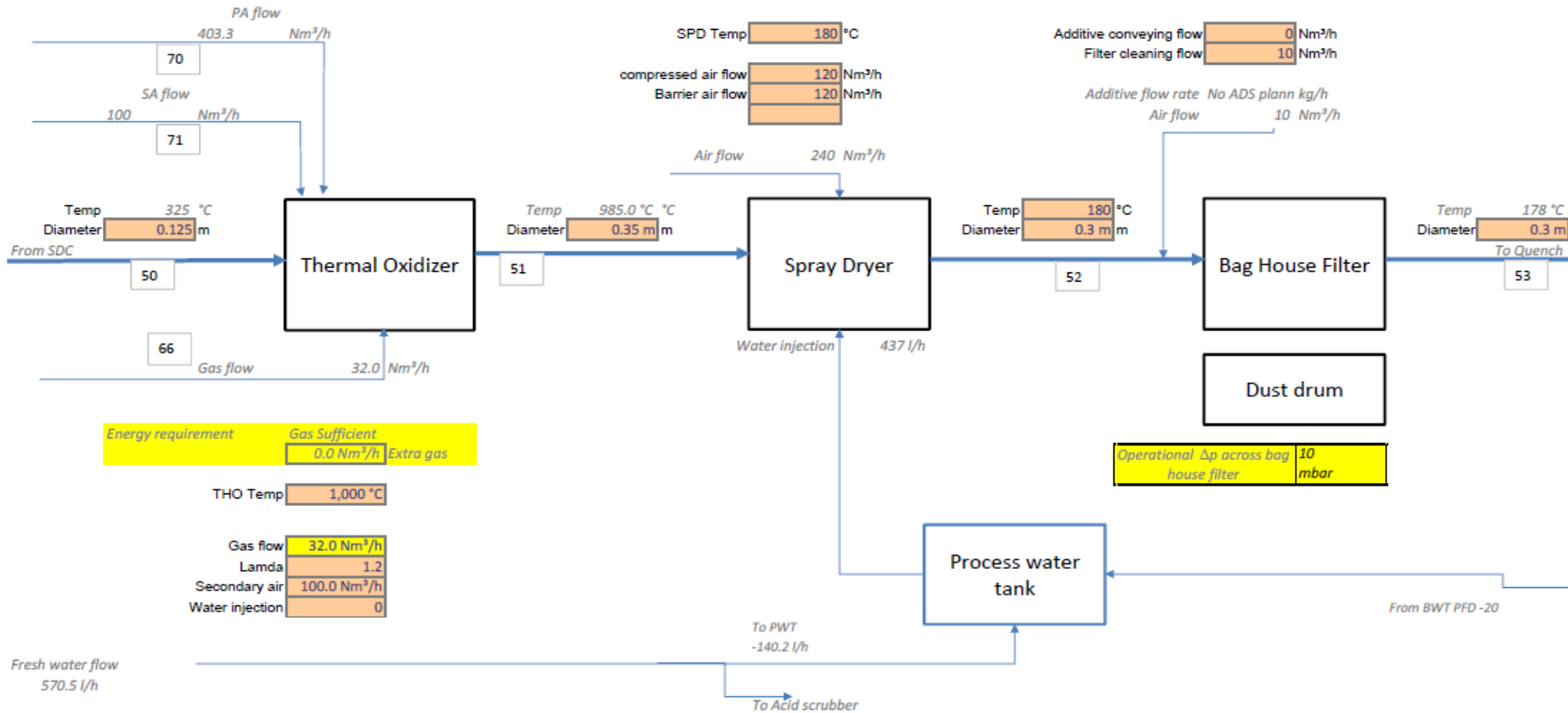

Stream No		50	51	52	53	66	70	71	72	76	77	78	80	87	91
Medium		Off gas	Off gas	Off gas	Off gas	Natural gas	Air	Air	Air	Comp Air	Comp Air	Comp Air			
Diameter	m	0.125	0.35	0.3	0.3	0.04	0.1	0.08	0.05	0.02	0.05	0.025			
Flow	Nm ³ /h	321.38	855.94	1639.54	1649.61	32.0	403.3	100.0	120	120	0	10			
Pressure	mbar	0	-10	-10.8	-20.8		20	20	100	3000	35	6000			
Temperature	°C	325	985	180	178	20	20	20	40	20	20	20			
Op Flow	m ³ /h	703.9	3983.5	2749.8	2779.7	34.3	424.4	105.2	125.2	32.5	0.0	1.6			
Velocity	m/s	15.9	11.5	10.8	10.9	7.6	15.0	5.8	17.7	28.8	0.0	0.9			
Pressure drop	mbar		0.8	0.48	1.02		3.8	0.64	14.78	81.9	#DIV/0!				
Chlorine	kg/h	17.3	17.3	17.3	17.3										
NOx															
Dust															
Heavy metal															

Conclusions



- Dynasafe has the expertise and tools to quickly develop purpose built solutions to meet specific Customer needs. These solutions are robust and predictable in terms of characteristics for strength, durability, process flow, etc.
- This translates into projects with low technical, financial and temporal risks.
- And most importantly, the conservative approach means safe systems in the field!



Thank you!

