

Tungsten Carbide Armor Piercing Technology

Small Arms Ammunition

2015

June 3

AP
Armor Piercing

SMALL ARMS AMMUNITION



Fredrik Erninge

Director Marketing and Programs
Nammo Small Caliber Division
Sweden

Nammo

Tungsten Carbide AP Technology

Agenda

- Nammo AP Product Portfolio
- AP Performance
- Tungsten Carbide Technology
- New Developments
- Summary

AP
Armor Piercing



Nammo

Nammo Tungsten Carbide AP Product Portfolio

World leaders in tungsten carbide armor piercing

- 15 active products in calibers;
 - 5.56 mm
 - 7.62 mm
 - 12.7 mm
 - .308 Winchester
 - .338 Lapua Magnum
- Pro-active engineering
 - Additional products under development
 - Pioneers on cobalt free tungsten carbide

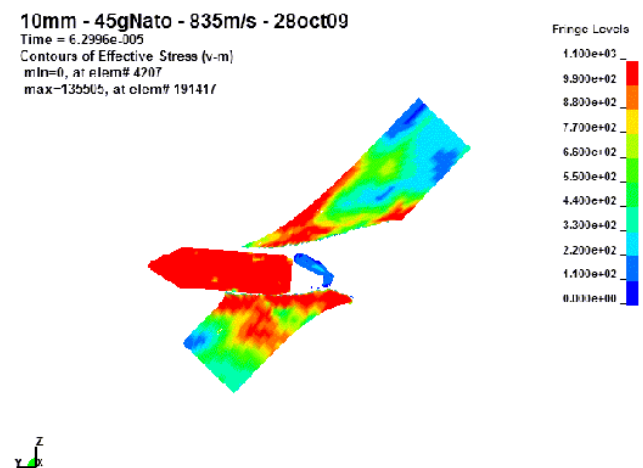

M993 & M995 Armor Piercing

- World leading Armor Piercing in caliber 5.56 and 7.62 mm
- Mature design, in production for 20 years



AP | 5.56
7.62
12.7
Armor Piercing
SMALL ARMS AMMUNITION

- Tungsten carbide penetrator
- Qualified as M993 and M995 by US Army 1996
- 160 million Armor Piercing cartridges delivered



M993 & M995



Live Fire Penetration Test – M993

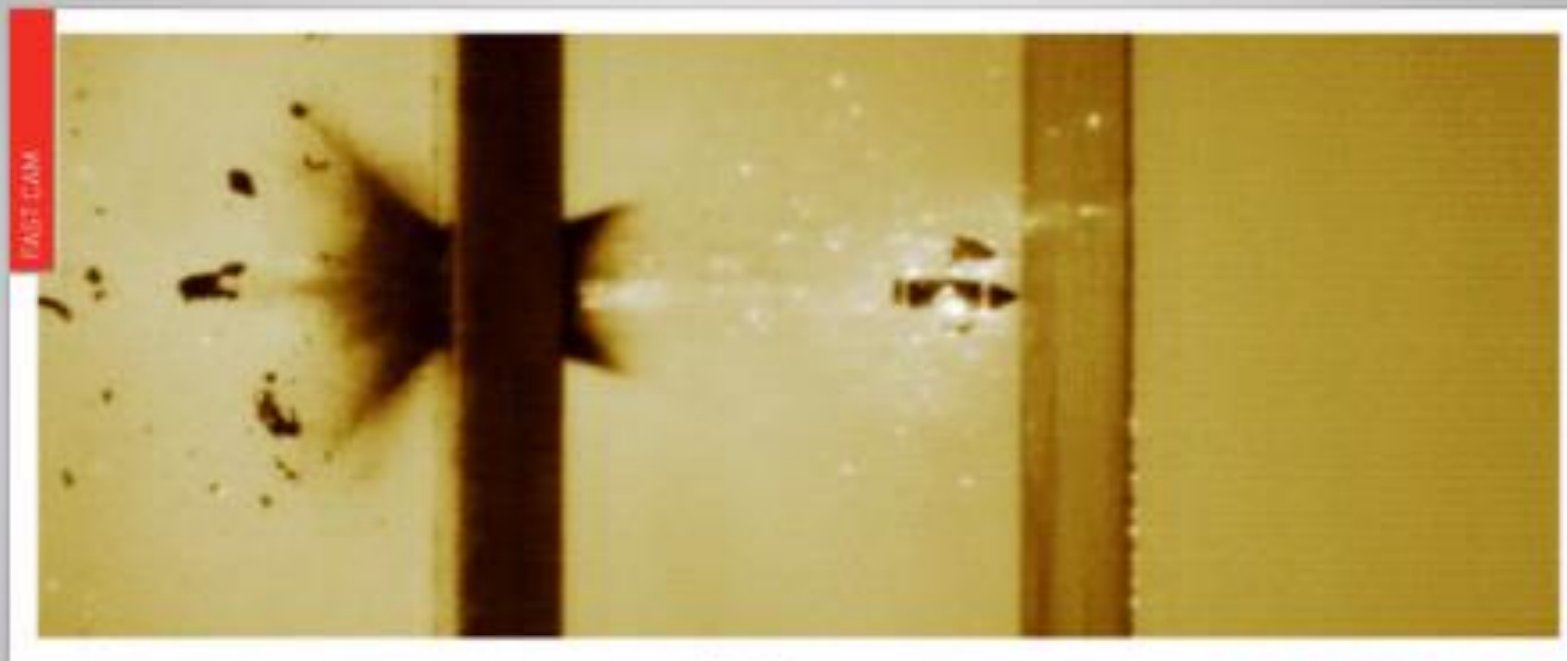

100 meter

CAM SPEED 25 000 fps



- 18 mm armor steel 300 HB
- Target distance 100 m
- Impact angle 0° Nato

5.56 & 7.62 mm Long Range AP

- Military specified STANAG 4172/2310
- 5 g (77 grain) / 10.9 g (168 grain) projectile
- Accuracy <1.5 MOA
- DMR or machine gun
- Long Range performance
 - Trajectory
 - Accuracy
 - Penetration



.50 Cal Armor Piercing

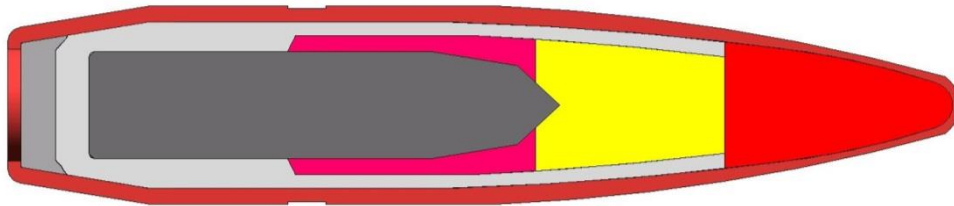

Multi Purpose Mk211
Trace & Dim Trace

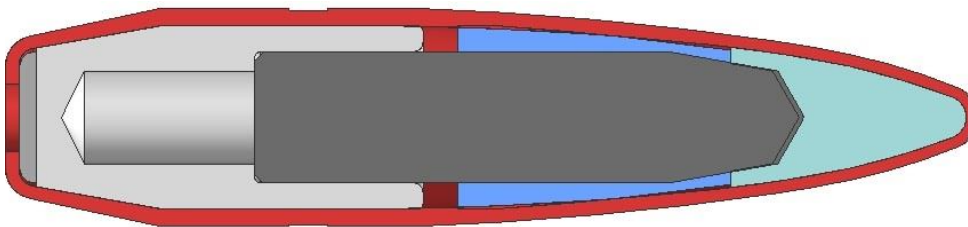

Armor Piercing Super
Incendiary

.50 Cal Armor Piercing Penetration

Penetration in a 15 mm armor plate

- **API-M8**
- **MP**
- **AP-S**

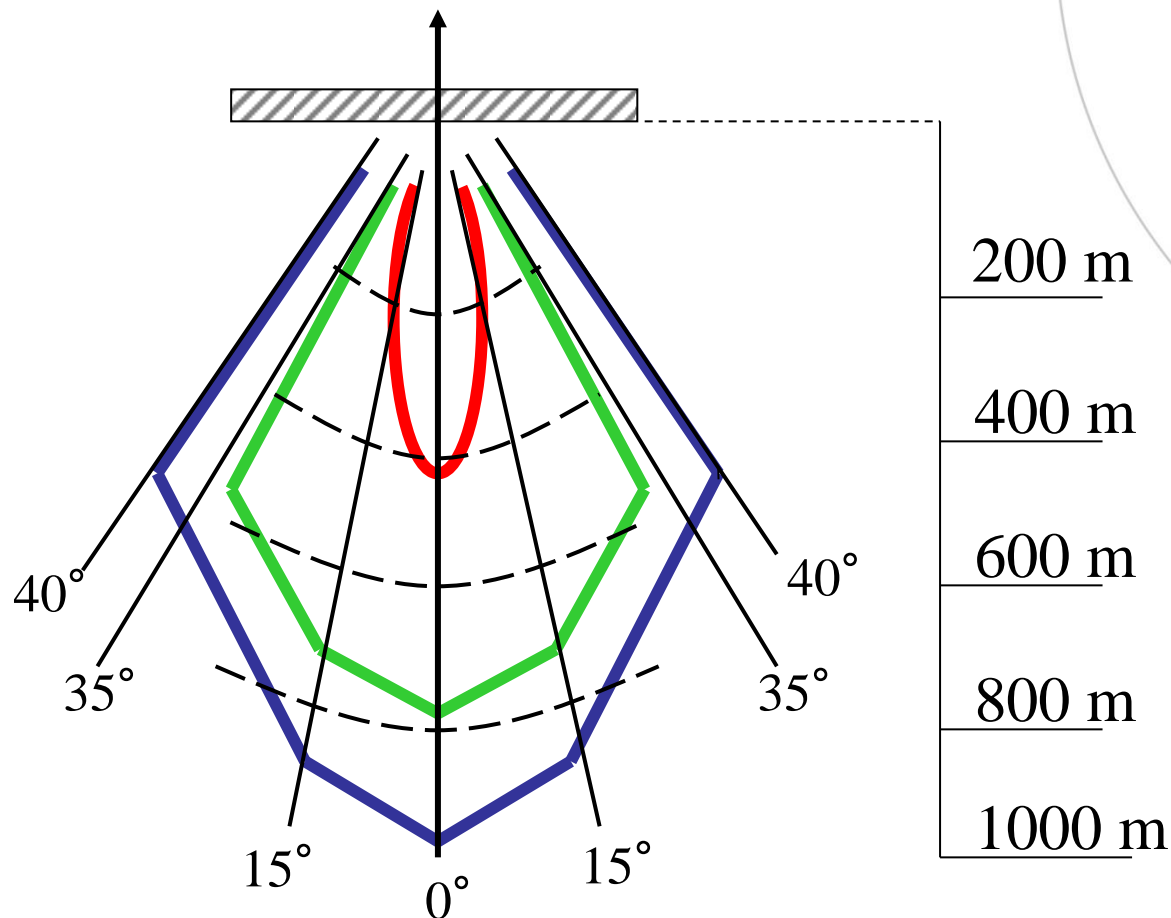

Anti-Material Sniper

- .308 Winchester AP – Matched to Scenar
- .338 Lapua Magnum AP and API – Matched to Scenar
- Match-grade bullet manufacturing technology
- World's most accurate AP's



Manufacturing Process Tungsten Carbide Core

From Raw materials ...



Grinding & Quality Control



Sintering



Pressing



Spray drying



Wet milling



... to Tungsten Carbide Core



Why Tungsten Carbide?

Steel

Density	8 g/cm ³
Hardness	600-800 HV

Tungsten Carbide

14.5 g/cm ³
1200-1500 HV

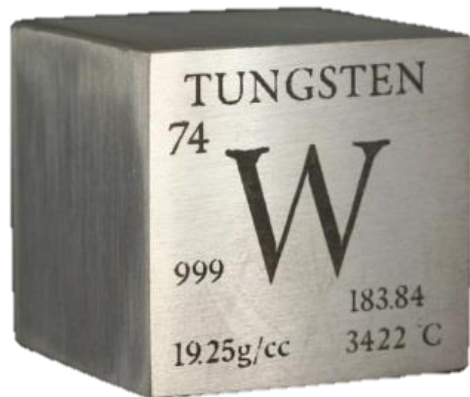

Utilizing Knowledge on Tungsten Carbide

- Worlds smallest tungsten carbide penetrator?
 - 1.1 g (17 grain) for 5.56 mm
 - 2.3 g (35 grain) for 7.62 mm

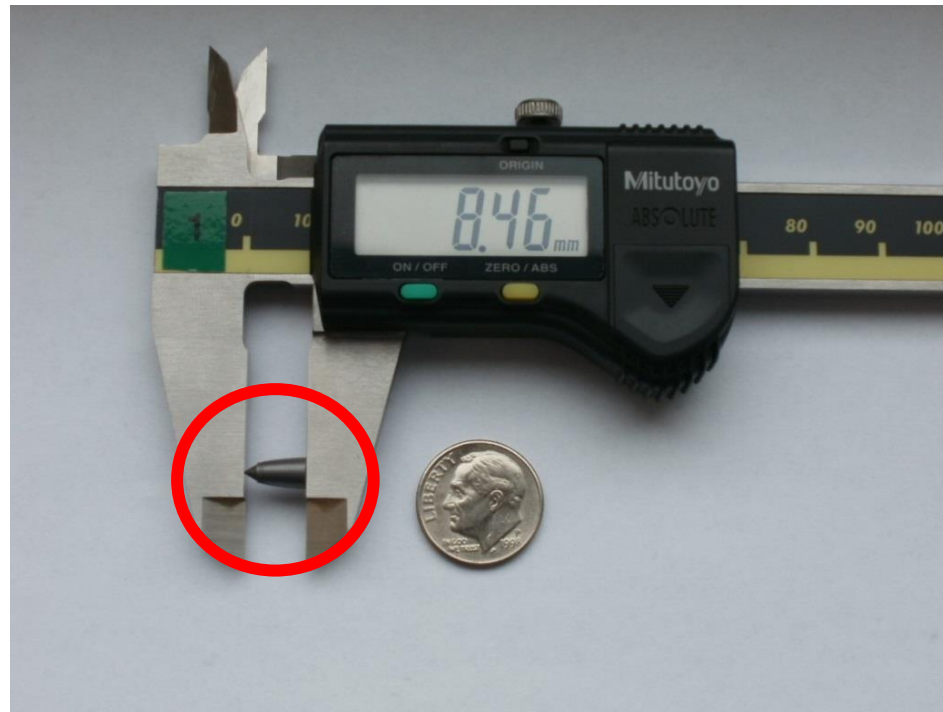

Power Ball – A New Product Family

- Ball with AP performance
- Based on Nammo lead free High Performance Ball
- Powered by Nammo AP penetrator technology
- Synergy effect
 - Armor Piercing
 - Long Range performance
 - Cost effective

5.56 mm: 4.5 g / 69 grain
7.62 mm: 9.9 g / 153 grain

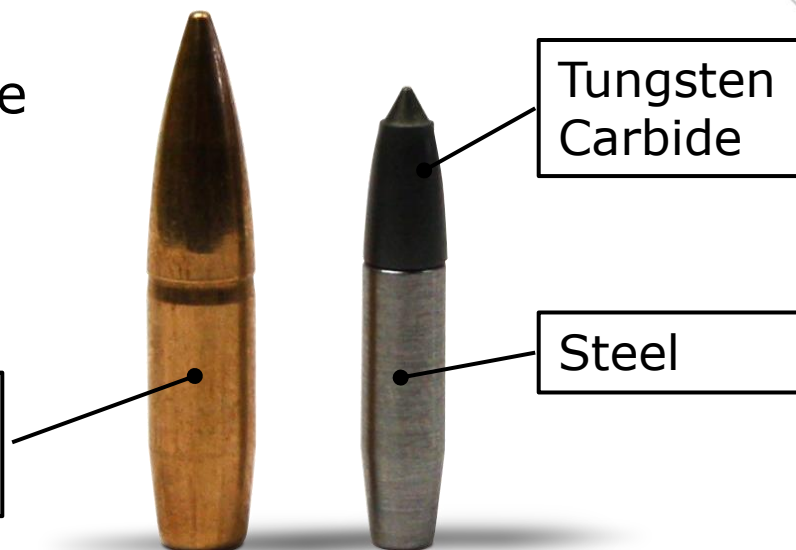

Power Ball – 5.56 mm Penetration

- 7 mm RHA 400HB at 0° impact angle at 200 m
- 7 mm RHA 400HB at 30° impact angle at 100 m
- 7 mm RHA 500HB at 0° impact angle at 100 m



Power Ball – 5.56 mm Penetration

3.5 mm NATO plate at 0° obliquity

M855 Ball

Penetration at 570 m

Nammo Power Ball

Penetration at 900 m



+ 58%

Power Ball – 5.56 mm Kinetic Energy

Increased combat distance compared to M855 Ball

- +13% kinetic energy at 100 m
- +36% kinetic energy at 500 m



Cobalt Free Tungsten Carbide Technology

- Cobalt is the most commonly used binder metal in the hardmetal industry
- Cobalt free means: Iron and/or Nickel

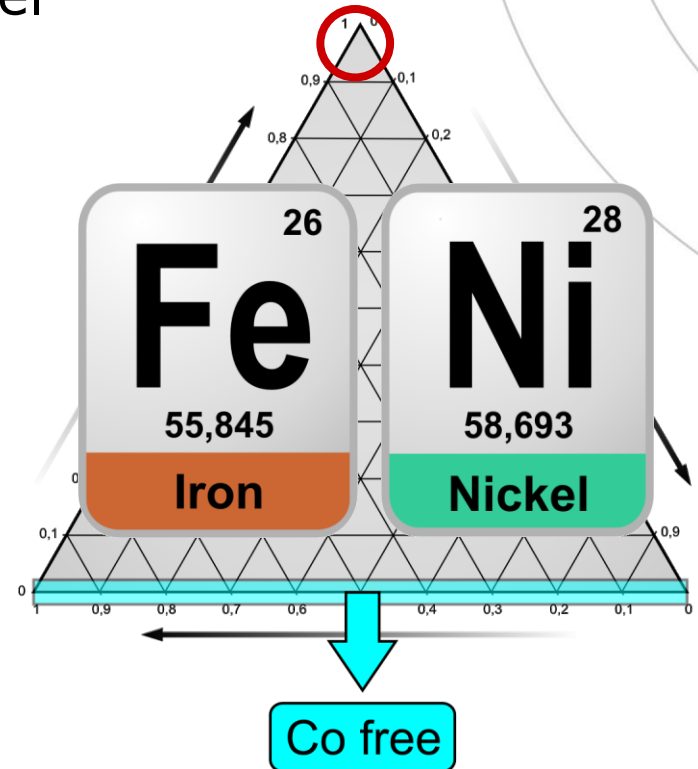
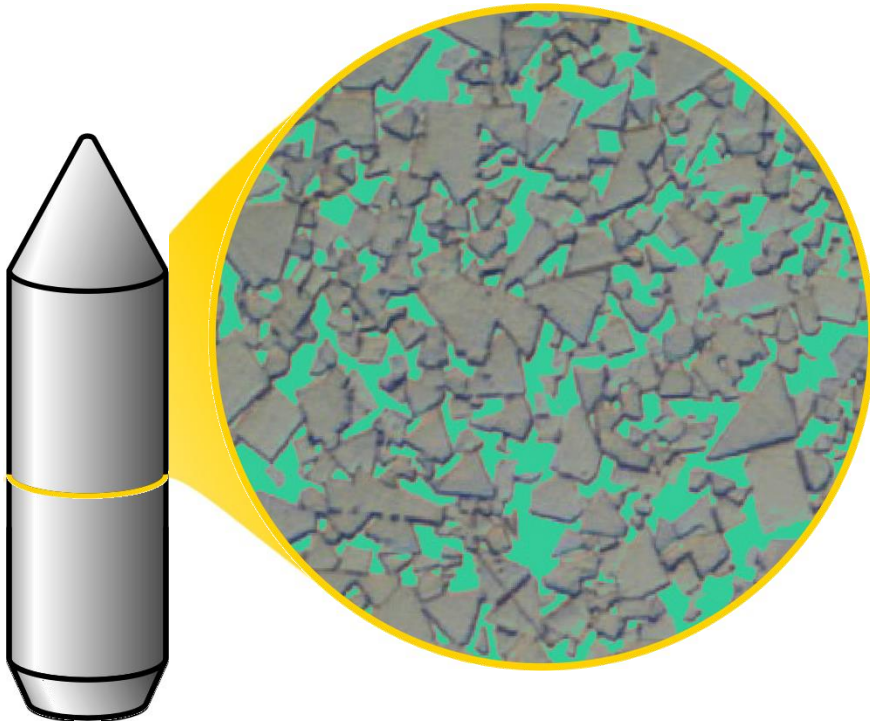

Nammo Can Provide an AP for Every Need

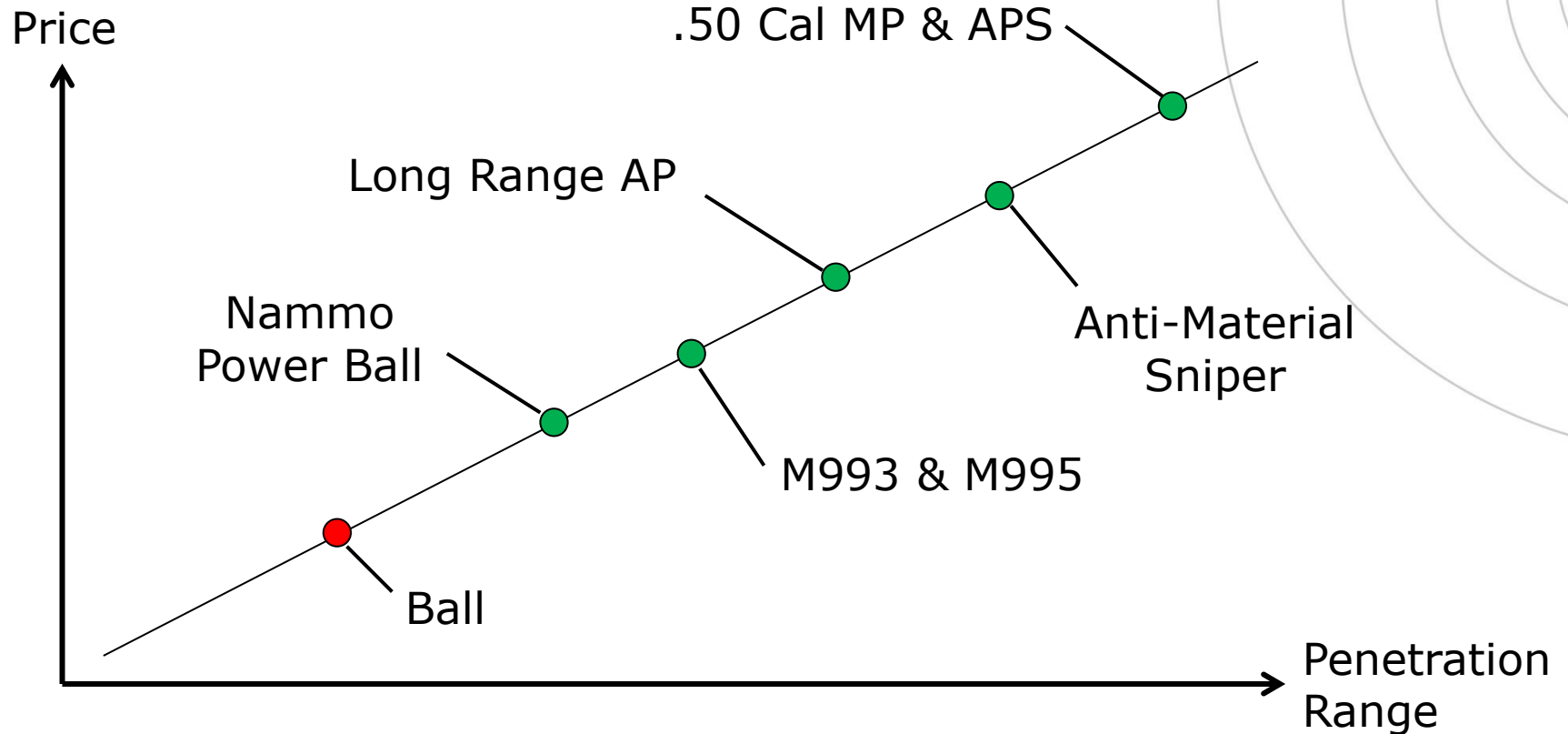

Tungsten Carbide AP Technology

Summary

- World leading tungsten carbide core AP
- 15 active products
- Tungsten Carbide – No Compromise
- New Developments
- An AP for every need



AP
Armor Piercing

nammo

Speaker information



Fredrik Erninge

Director Marketing and Programs

Nammo Small Caliber Division

+46 505 182 07

fredrik.erninge@nammo.com