

DEFENSE LOGISTICS AGENCY

AMERICA'S COMBAT LOGISTICS SUPPORT AGENCY

DLA Land and Maritime

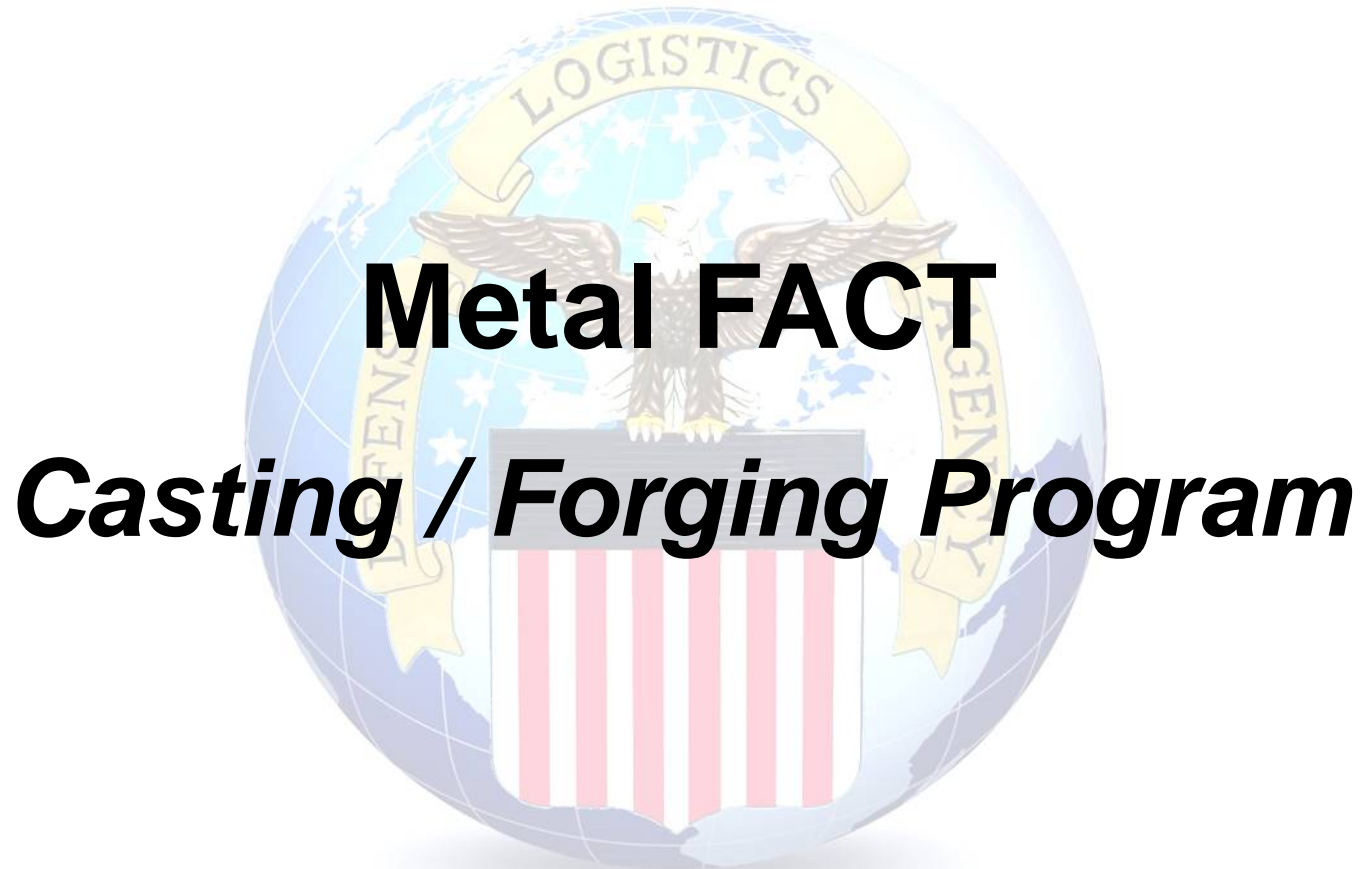



History



Casting Program

- Been around about 20 years
- ManTech R&D Program
- Support DLA and Foundry Industry

Forging Program

- Established 5 Years after the Cast Program
- ManTech R&D Program
- Support DLA and Forge Industry



Overview



- Provides Assistance to DLA Managed NSNs
- MetaLFACT Comprised of Government / Industry Representation
- MetaLFACT is a Resource Available to:
 - *DLA personnel*
 - *Engineering Support Activities*
 - *Contractors/Suppliers*
 - With active DLA L&M contracts
 - With Contracting Officer's approval
 - Bidding on open DSCC solicitations



Support Tools



- **DECAF – DLA Enterprise Cast and Forge Database**
- **ICON – intent to replace 3 existing databases**
 - *Cast tooling database*
 - *Supplier database*
 - *Toolkit database*
- **NFTD – National Forging Tooling Database**
- **FIA RFQ – Forging Industry Assoc. Request for Quote (posting)**



Accomplishments



- **DECAF NSN population confirmed cast and/or forged**
 - 20,325
- **Contracts in last 12 months**
 - 13,014 valued at \$9.6M
- **Active purchase requests**
 - 1,159
- **Current backorders**
 - 5,205 lines with a total quantity of 72,483



Program Engagement



- Mailbox – DSCC.cast.forge@dla.mil
- Standard Text Object (STO) inputted in Purchase Order Text (POT)
 - *A1202, ZD003, ZD004, and ZD054*
 - A1202 – may contain
 - ZD003 / ZD004 – does contain content
 - ZD054 – in internal comments for DLA personnel





DEFENSE LOGISTICS AGENCY

AMERICA'S COMBAT LOGISTICS SUPPORT AGENCY

DLA Land and Maritime

Replenishment Parts Purchase or Borrow Program (RPPOB)





Overview



- **Designed to allow vendors to visually inspect, borrow or purchase government owned material**
- **Provides DLA stock to vendors for reverse engineering**
- **May result in a Source Approval Request (SAR)**
- **Statutory requirement to perform RPPOB**
- **Typical timeline is 12 to 18 months for full approval**
- **Minimum \$10K annual buy value**
- **Joint certification program (JCP) may be required**
- **Item must be in stock**



Purpose



- **Statutory Requirement**
 - *Defense Procurement Reform Act of 1984*
 - *Public Law 98-525, Section 1216(a)*
 - *Codified at Title 10 U.S.C. 2320(B)*
- **Development of New Sources of Supply**
 - *DoD Instruction 4140.57*
- **Perform reverse engineering in the development of a technical data package**

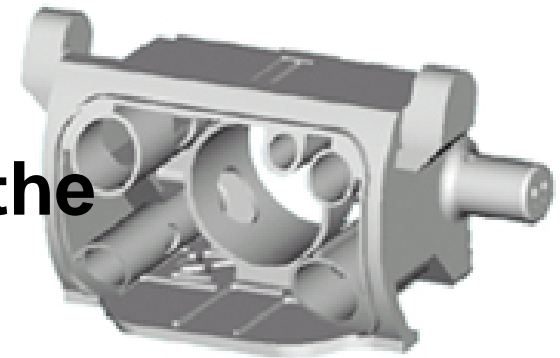



Methods



- **Direct Purchase**

- *Contractor purchases at Standard Unit Price (SUP)*
- *Item is not returned*

- **Bailment**

- *Item loaned at SUP*
- *SUP held in trust by DFAS*
- *SUP monies returned if item is returned in original condition*

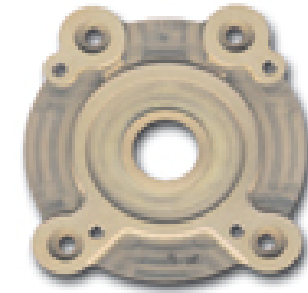

- **View Parts**

- *Contractors may inspect part in a designated area*
- *Pictures can be sent*



Guidelines

- **Not available on NSNs with Acquisition Method Suffix Codes (AMSC) of B, G, and T**
 - *Source controlled drawings*
 - *Full and open competition*
 - *Specification controlled drawings*
- **Not available on NSNs with less than \$10,000 annual buy value or with multiple years of stock on-hand.**
- **Not to compare with other approved sources' stock.**
- **Not to find out information on an NSN after being awarded a contract**



Submission Criteria



- **Personal Name**
- **Company Name**
- **Company Cage Code**
- **Company Phone Number**
- **Company Shipping Address**
- **National Stock Number (NSN)**



Benefits



- **Break sole source**
- **Provide additional sources on limited source items**
- **Potential for unlimited right technical data packages**
- **Increased competition means lower cost to taxpayers**





Metrics (2014 – Present)



- **742 bailment requests**
- **99 different cages**
- **190 signed bailment agreements**
- **55 SAR package submittals**
 - *4 rejected*
 - *11 pending*
 - *40 Approved*
- **23 NSNs awaiting next procurement**
- **17 NSNs procurement actions occurred**
- **Savings to date \$2,719,069.36**



Points of Contact

- **DLA Land and Maritime**
 - DSCC.Partrequest@dla.mil
- **Submitting complete Alternate Offer/SAR package:**
 - DSCC_AO-SAR@dla.mil
- **For Questions in submitting Alternate Offer**
 - DSCC.AltOffer.PM@dla.mil

Candidate Website

<http://www.dla.mil/LandandMaritime/Offers/Services/TechnicalSupport/ValueMgtDiv.aspx>





DEFENSE LOGISTICS AGENCY

AMERICA'S COMBAT LOGISTICS SUPPORT AGENCY

DLA Land and Maritime

Source Approval Request (SAR)





Definition



- **A Source Approval Request (SAR) package is an assembly of information required of a prospective new supplier for a specific item (NSN) that is currently procured as other than full-and-open**
 - *Source Controlled (AMSC B)*
 - *Source Restricted (AMSC C)*
 - *Code & Part Number (AMSC D)*
- **A SAR package contains all technical data needed to demonstrate that the prospective contractor can competently manufacture the NSN to the same level of quality or better than the approved source**
- **The SAR submitted for evaluation should be in accordance with the SAR guide checklist**



Evolution



- **Lean 6-Sigma Black Belt Project (SEP 11-JUN 12)**
 - *Centralized tracking of receipts and notifications*
 - *Streamlined DLA process*
 - *Improve DLA acceptance rate*
- **VE Process Improvements**
 - *Centralized process tracking*
 - *Expanded analysts roles*
 - *Developed candidate NSN list & sample SAR*
 - *Improve ESA acceptance*
 - *Review packages outside of savings*
 - *DLA/contractor partnership (missing data, status)*
 - *Procedure change*
 - **DAG 17.7501-6 : Retention of Newly Approved Alternate Sources**



Process



- **Identify potential items (NSNs) of interest**
 - *Search...DIBBS, Haystack, SERVA (PTACs can help)*
 - FSCs, item description, characteristics, OEM CAGE
 - *DLA candidate list's*
 - Obsolescence / limited competition
- **Assemble SAR package data (follow guide)**
 - *Company information (manufacturing and quality)*
 - *Current part data and your data*
 - SAR guide categories (OEM Data)
 - Reverse Engineering (OEM Part)
 - *Business case*
 - *Actual data and/or test plan*

VE Link (SAR Process, SAR Template, SAR Candidate List)
[\(http://www.landandmaritime.dla.mil/offices/valuemanagement/\)](http://www.landandmaritime.dla.mil/offices/valuemanagement/)



Process (cont.)



- **Submit SAR package**

- *As Alternate Offer (AO) (open solicitation)*

- To Contracting Officer
- To Competition Advocate Office (CAO)/AO Monitor

- *As Source Approval Request (no active solicitation)*

- To Competition Advocate Office (CAO)/AO Monitor

- **Government reviews**

- *CAO*

- Initial review, log case, notification

- *Value Engineering (VE)*

- Business case, technical review, tracking, contractor awareness

- *Engineering Support Activity (ESA)*

- Weapon system engineering evaluation)



Start to Finish Summarization



- **Contactor submits package**
- **Comp Ad receives package**
 - *Notification of receipt sent to contractor*
 - *Log package into SAR tracking system*
 - *Package forwarded to Value Engineering (VE) within 5 days*
- **VE receives package from Comp Ad**
 - *Analyst performs review (7 resources)*
 - Review performed within 15 days
 - *Package complete*
 - Forwards package to ESA
 - *Package incomplete but potential for rework*
 - Notifies contractor and requests missing data (30 day)
 - If data not received, rejects package to CAO with reasons
 - *Package incomplete*
 - Notifies CAO with reasons



Start to Finish Summarization



- **ESA receives package**
 - *ESA reviews package (90 day response time)*
 - *ESA accepts, rejects or requires more data*
 - *ESA completes review and closes out*
- **VE receives ESA response**
 - *Concur or not concur with ESA response (15 days)*
 - *Notify Comp Ad ESA response received*
 - *Gather additional contractor data (if applicable)(30 days)*
 - *Take cataloging action in adding source (if applicable)*
- **Comp Ad closes out packages (approved/rejected)**
 - *Sends official notification letter to contractor (5 days)*



Government Responses



- **Technical Data is Available for Viewing (Competitive)**
- **SAR Package Data Missing**
 - *Will be contacted for missing data*
- **Need to Complete Qualification Testing**
 - *Good on paper, but need to prove will work in application*
- **Rejected**
 - *Business case/not in the best interest of the government*
 - *SAR package is incomplete (contractor failed to supply)*
 - *Weapons criticality*
 - *Application upgrade and/or discontinued*
 - *Can't validate part (no government data to compare)*
- **Accepted**
 - *Company cage/part number added as approved source*

Final official notification sent via CAO letter



Procedure Change



- **DAG 17.7501-6 (Retention of Newly Approved Sources)**
 - *Implemented on 17 June 2014*
 - *Sole Source breakout*
 - *Utilization of multi-source award clause for a minimum of 1 year from approval date and/or 1st award*
 - *If not low, but fair and reasonable based on previous contract price 40% of the award will be given to the newly approved source*
 - *NSNs will be removed from auto-solicitation and Long Term Contracts (LTC) unless circumstances dictate otherwise*



Metrics



- **211 Packages Received**
- **55 Packages Approved**
 - *\$2.35M potential annual savings*
- **184 Packages Pending**
 - *\$28.5M potential annual savings*
- **90% in VE Package Acceptance Rate**
 - *29% increase from previous FY*
- **\$17.6M FY16 Expanded Competition Savings**



Resources

- AO/SAR submission – (email – 8MB) dscs_ao-sar@dla.mil
- Mail (printed and/or CD copies)

U.S. Postal Service Address	UPS or FEDEX Address
DLA L&M Alternate Offer Monitor – BPP Directorate of Business Process P.O. Box 3990 Columbus, OH 43218-3990	DLA L&M Alternate Offer Monitor – BPP Directorate of Business Process 3990 East Broad Street Columbus, OH 43213

- AO/SAR process questions – dscs_altoffer_pm@dla.mil
- Technical Issues (Engineering/Analysts) – ve_sar@dla.mil
- Checking if drawings available – dscs_cddwgs@dla.mil
- RPPOB - DSCS.PartRequest@dla.mil
- DLA Small Business support – dscs_bcc@dla.mil
phone 1-800-262-3272



