



# 2016 Insensitive Munitions (IM) & Energetic Materials (EM) Technology Symposium

**ABSTRACT # 18689**  
**USE OF PACKAGING METHODOLOGIES AND INNOVATIVE MATERIALS TO PREVENT INADVERTENT REACTION OF NAVAL ORDNANCE**

**15 September 2016**

**Bob Van Schaack**  
**Senior PHST Engineer**  
**NSWC Indian Head Explosive Ordnance Disposal (EOD) Technology Division**  
**Picatiny Det, Code G1E**  
**Naval PHST Center**  
[robert.vanschaack@navy.mil](mailto:robert.vanschaack@navy.mil)  
**(973) 724-9802**

*Final. Distribution Statement A: Approved for Public Release; Distribution is unlimited.*



# What is the Naval PHST Center?

---

- **Chain of Command:**
  - Systems Integration Department, Division G1
  - Detachment of NSWC Indian Head EOD Technology Division
- **Location:** Picatinny Arsenal , NJ
- **Description:** 65 engineering professionals dedicated to the Packaging, Handling, Storage & Transportation (PHST) of Naval ordnance programs for over 60 years.
- **Mission:** Provide Fleet, Program Managers and other customers with complete life cycle engineering and logistics support services for PHST of weapons and combat systems equipment.
- **Strengths:** In-house capability, knowledge and experience in requirements, design/development, test, acquisition, documentation and field support of Naval ordnance PHST.



# NAVAL ORDNANCE PACKAGING

---

- ***Naval Ordnance spends almost its entire life in its package***
- ***Naval Ordnance is expensive, often sensitive, and hazardous***
- ***Naval Ordnance is shipped many times during its life***
- ***Rigorous shipping environment***
  - Air, Road, Sea, Field
- ***Unique environments and handling***
  - VERTREP, CONREP

# CONREP/VERTREP



# NAVAL CONTAINER REQUIREMENTS

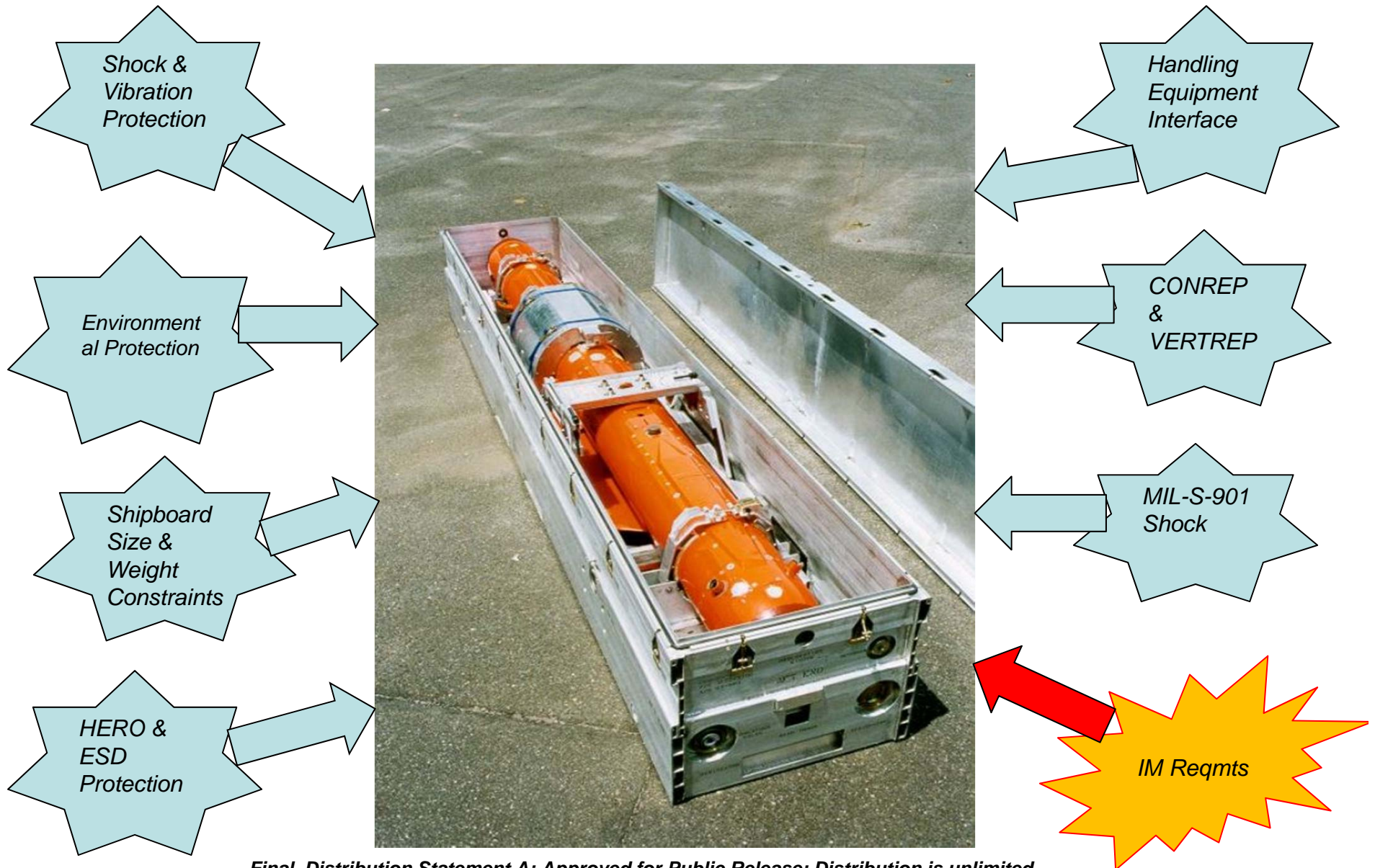



# IM REQUIREMENT - PACKAGING

---

- Prior to 2006, the main requirement imposed on weapon in logistical (packaged) configuration was Sympathetic Detonation
- In 2006 the Joint Requirements Oversight Council (JROC) memorandum recommended a standardized, single set of Insensitive Munitions (IM) tests and passing criteria for use by all Components for assessing IM compliance
  - All IM tests to be conducted in logistical (packaged) configuration in addition to operational configuration testing
  - Sympathetic Reaction, Bullet Impact and Frag Impact are tests most likely to benefit from container IM solutions



# IM REQUIREMENT - PACKAGING

---

- Ideal IM Solution is a systems approach with an operationally effective explosive fill that is insensitive enough to meet the IM requirements without, or with minimal, changes to operational logistics (e.g. adding shielding to the packaging)
- New weapons program challenges
  - R&D Costs for researching new explosive fills
  - Meeting all operational requirements with less sensitive fill
- Legacy weapons programs
  - Changing explosive fills expensive
  - Modifications to operational logistics (PHST) often seen as cheapest and easiest way to meet IM requirements



# IMPACTS

---

- Change to Insensitive Explosive Fill:
  - No Impact to Fleet Manpower
  - Minimal to no impact on PHST design & test requirements
- Change to Operational Logistics (PHST):
  - Impact to Fleet Manpower
    - Special Stowage Patterns
    - Addition of shielding to containers
      - Increases container size, cost and weight
      - Can Decrease Handling Efficiency and Increase manpower during packing/unpacking
  - PHST Impact - Modifications must still meet container design and test requirements





# IM PACKAGING CONSIDERATIONS

---

- **Cost**
- **Size**
- **Weight**
- **Material Compatibility**
- **Securement Methods**
- **Producibility**
- **Operability/Human Factors**



# PACKAGING STRATEGIES TO PREVENT INADVERTENT REACTION OF ORDNANCE

---

- Stowed Configuration of Ordnance
  - Can be Used for Sympathetic Reaction and Shaped Charge Jet Requirements
    - Weapons Packaged Head to Tail
    - Cant weapon in Container (i.e. packaged with nose of weapon angled downward)
    - Offset Warheads
    - Spacing of Ordnance in containers or in Magazines
- Incorporating Shielding into Container Designs
  - Can be used for Sympathetic Reaction, Bullet Impact & Frag Impact
  - Aluminum or Steel Plates
  - Pumice
  - Other Materials (composites, Spectra, Dyneema, etc.)
  - Combination of Materials

# AMRAAM MISSILE CNU-415B/E CONTAINER

**IM SOLUTION:** Sympathetic Detonation

**METHOD OF COMPLIANCE:** Missile Orientation

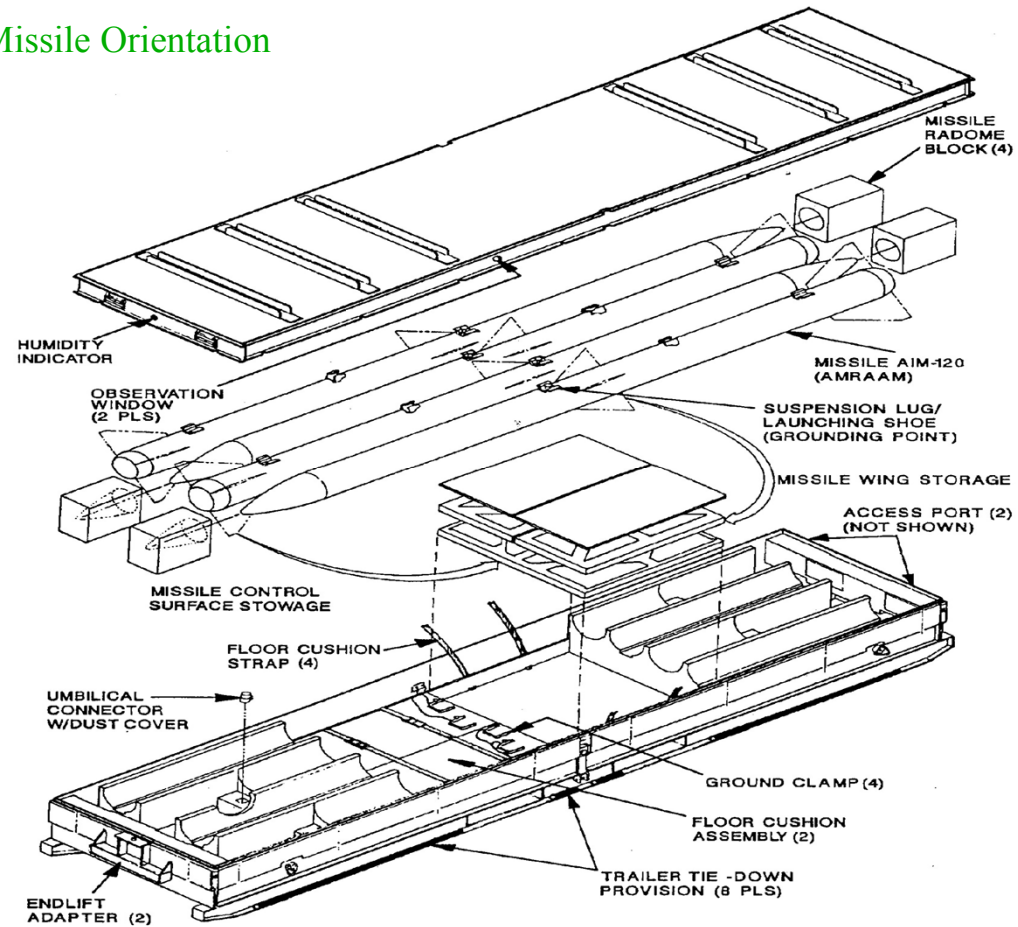

# SLAM MISSILE MK 724 MOD 1 CONTAINER

IM SOLUTION: Sympathetic Detonation

METHOD OF COMPLIANCE: Aluminum Plates

- 2" Thick Center Plate
- 1" Thick Side Plates
- .25" Thick Bottom Plate (Not Shown)

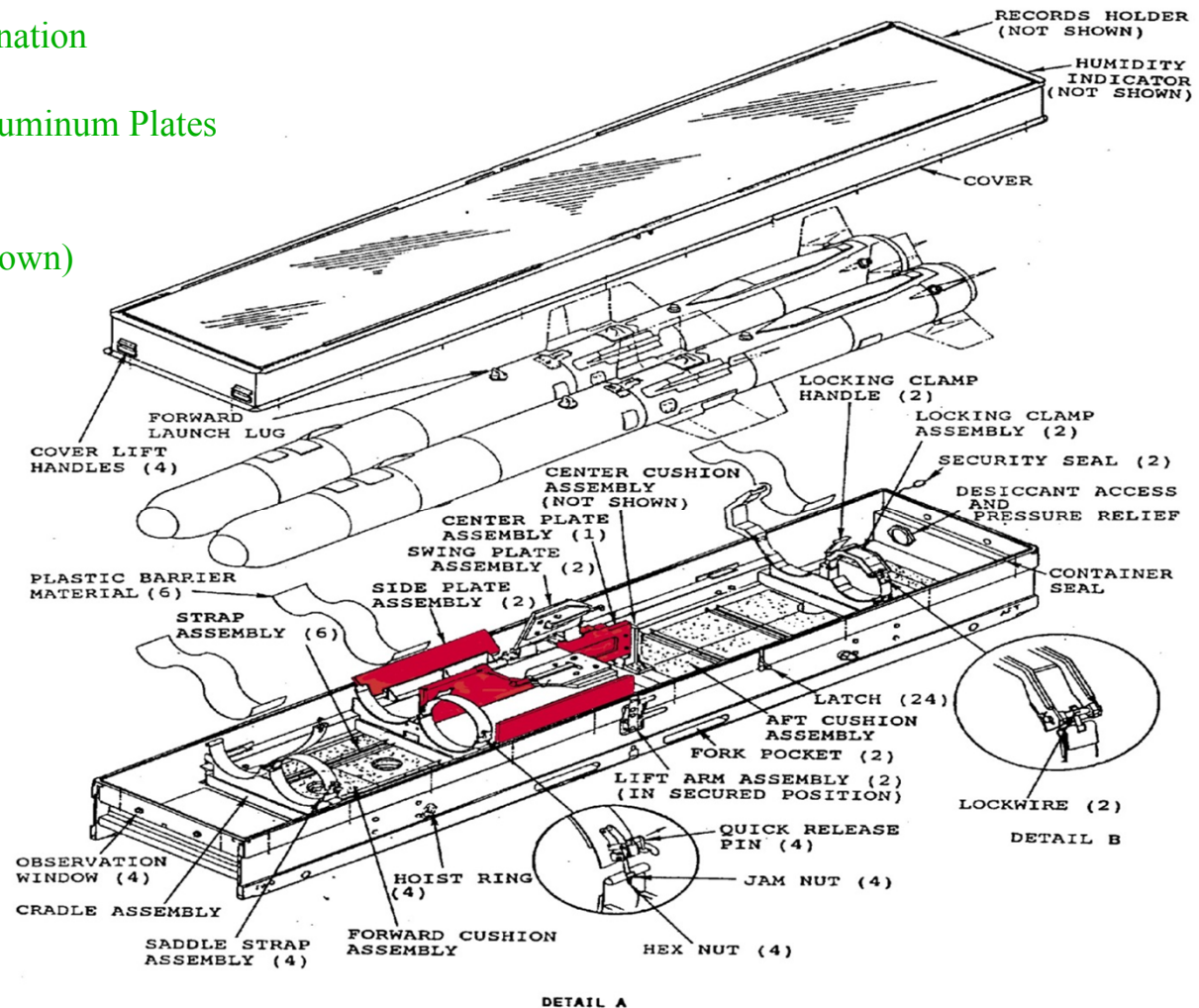



# SLAM-ER MISSILE CNU-595/E CONTAINER

**IM SOLUTION:** Sympathetic Detonation

**METHOD OF COMPLIANCE:** Pumice Shields and Aluminum Plates

17% Cost Increase  
15% Weight Increase

Upper IMSD Shield - Aluminum Shell Filled with 4" Pumice/Epoxy Mix

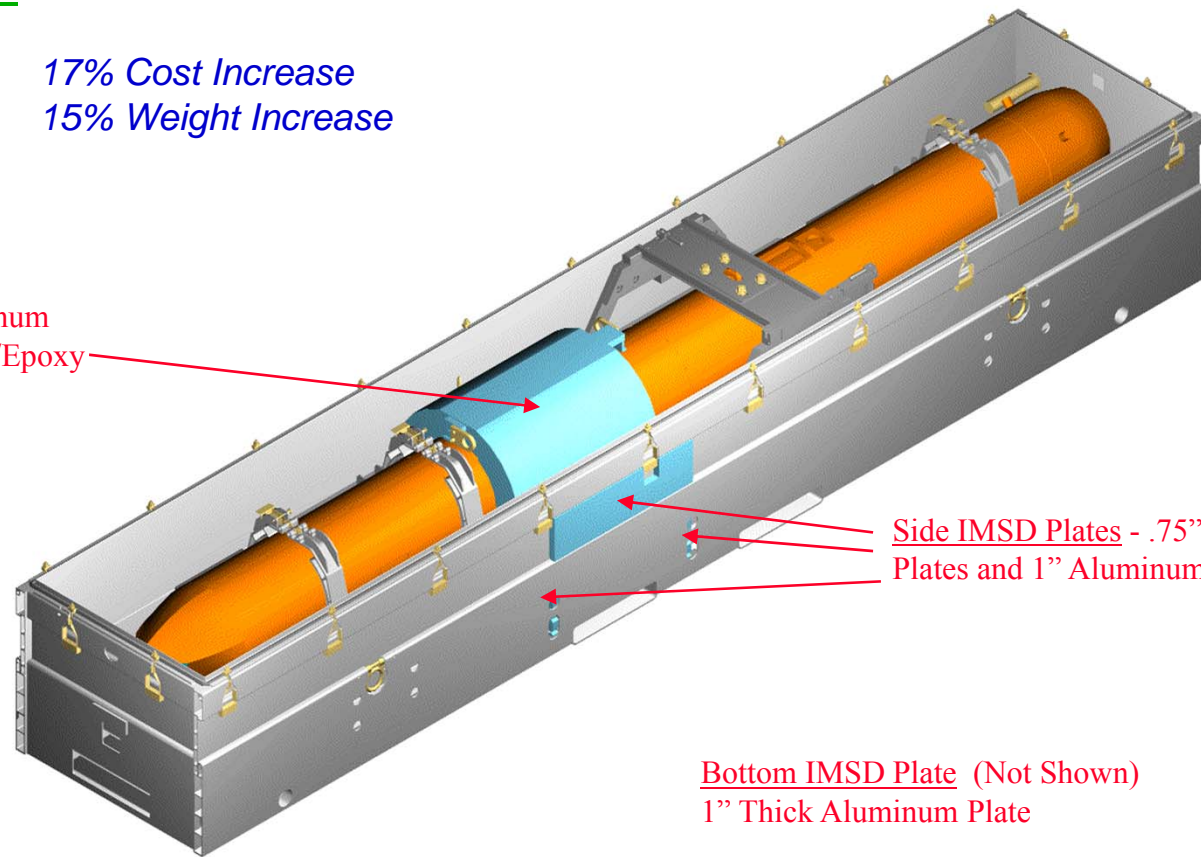

Side IMSD Plates - .75" Aluminum Plates and 1" Aluminum Bar stock

Lower IMSD Shield (Not Shown)  
Aluminum Shell Filled with 4"  
Pumice/Epoxy Mix

Bottom IMSD Plate (Not Shown)  
1" Thick Aluminum Plate

# JSOW CNU-575/E CONTAINER CRADLE REDESIGN

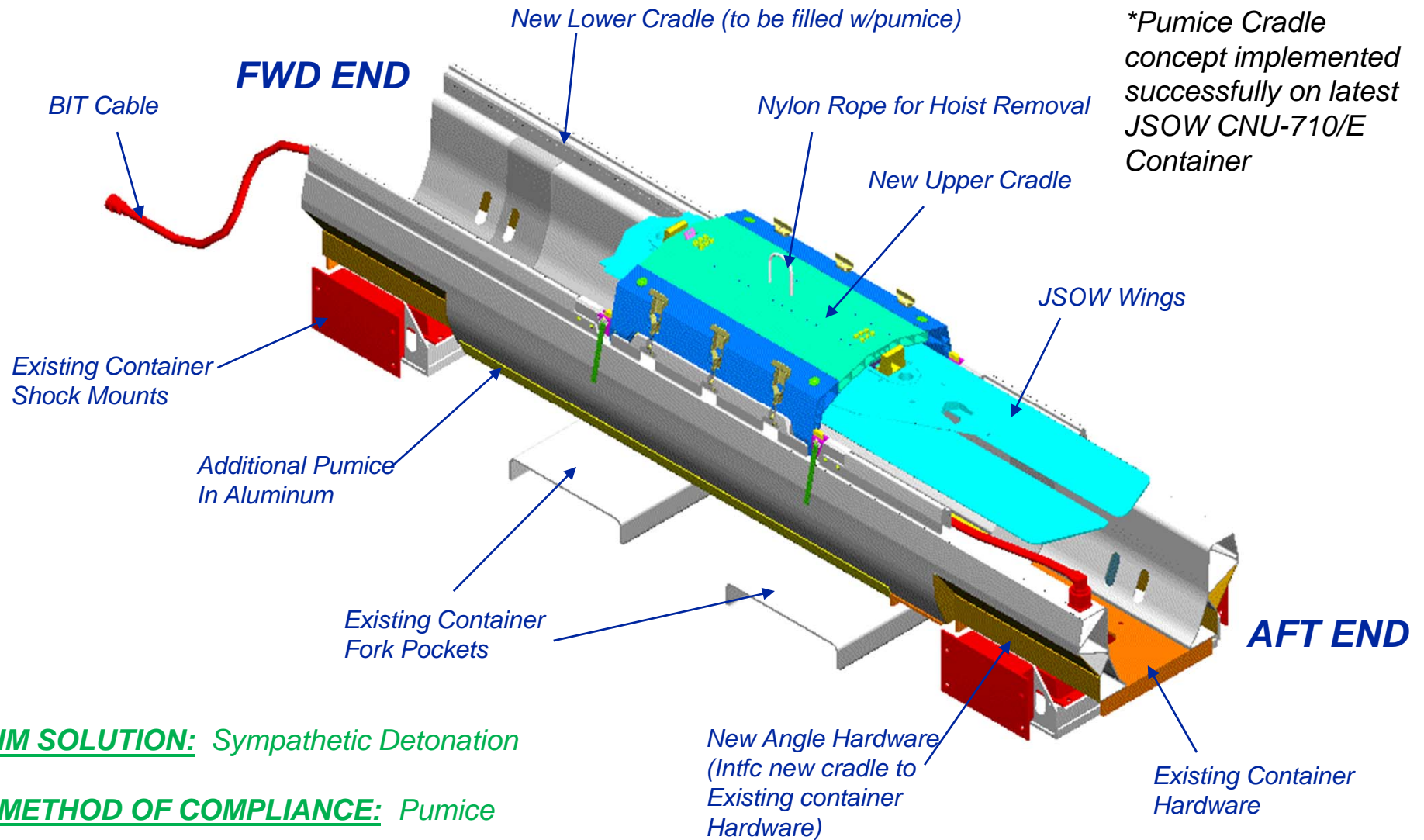

**IM SOLUTION:** Sympathetic Detonation

**METHOD OF COMPLIANCE:** Pumice

# MK 812 MOD 0 CONTAINER

**IM SOLUTION:** Sympathetic Reaction,  
Shaped Charge Jet, Fragment Impact

**METHOD OF COMPLIANCE:** Carbon Fiber,  
Aluminum and Spectra/Dyneema Shield;  
Nose Down Tilt of Weapon in Container

24% Weight Increase  
167% Cost Increase



MK 812 MOD 0 Container Shield

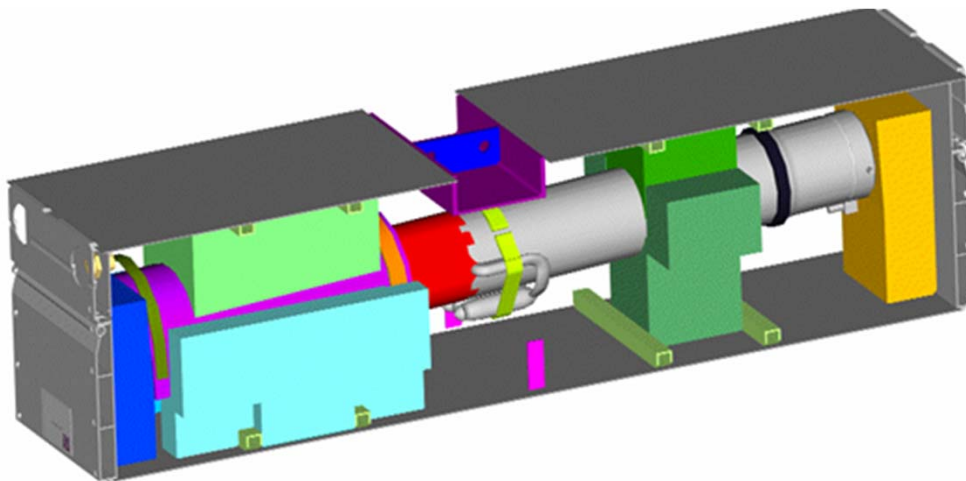

Nose Down Tilt

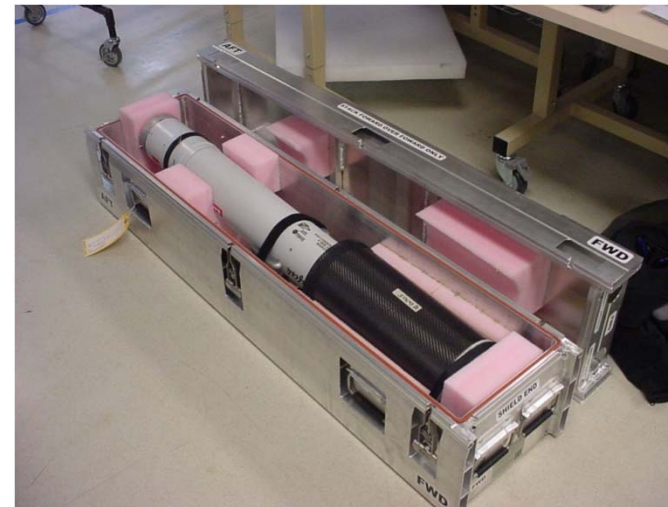

MK 812 MOD 0 Container

# HARPOON CNU-706/E CONTAINER

**IM SOLUTION:** *Sympathetic Reaction*

**METHOD OF COMPLIANCE:** *Weapon Orientation, 3/4" thick bottom AL plate*

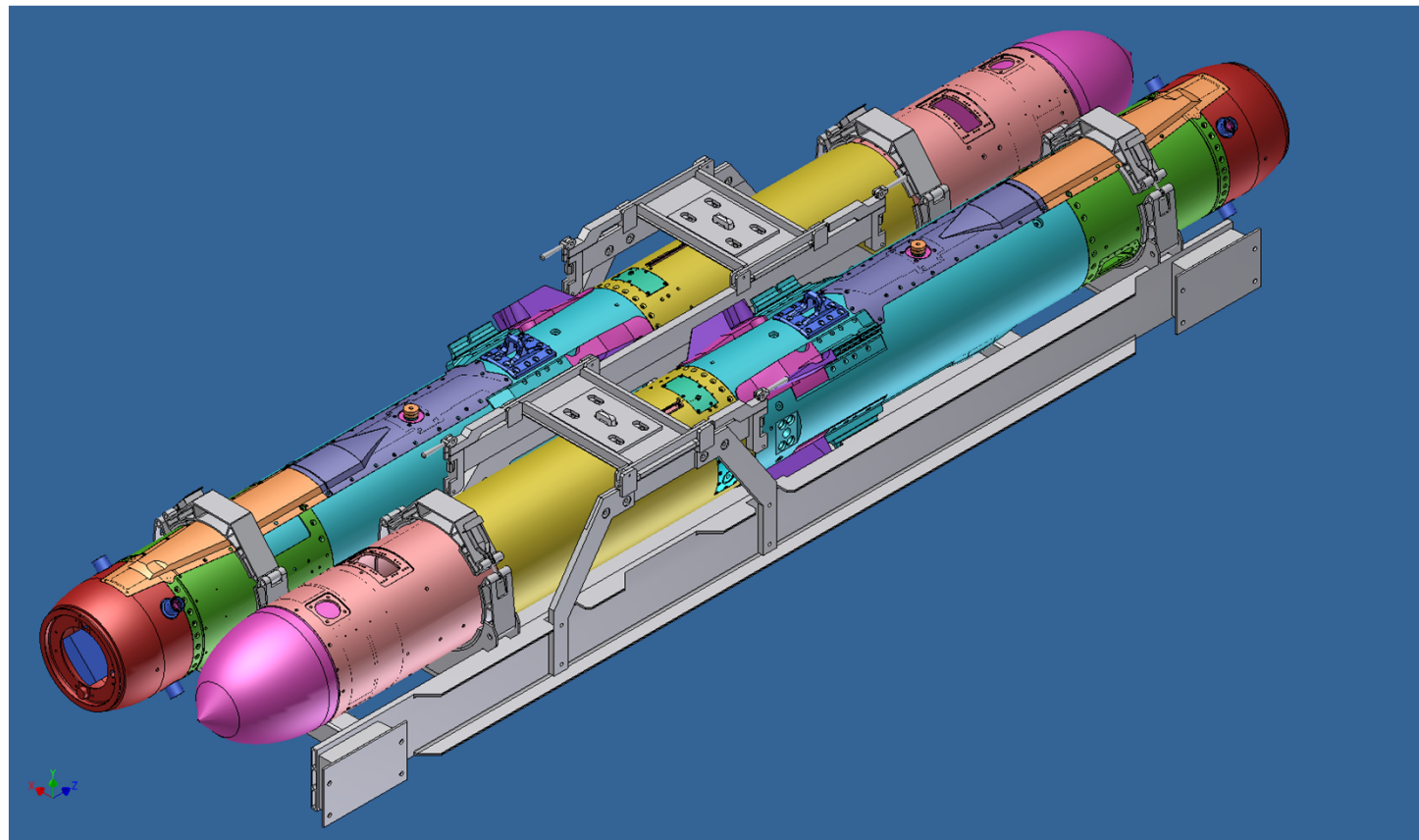





# IM CHALLENGES

---

- Size & Weight/ Stowage Density
  - Additional space needed for shielding
    - If extra space is not available inside of container, container size may need to grow
  - May restrict number of items per container
    - Multi-round containers at maximum width or weight may not have room for shielding or extra space between rounds
    - Can result in one or more rounds being removed from the container
    - Overall shipboard stowage density will decrease



# IM CHALLENGES

---

- Cost
  - Shielding material will drive up the cost of a container
  - Some materials, such as ceramics, are more costly than others, such as steel
  - Supporting the shielding may result in increased fabrication costs
- Operational Logistics
  - Need to ensure impact to Fleet manpower and workload is minimized



# TAKEAWAYS

---

- All IM requirements now apply to items in logistical configuration
- Container can play important role in meeting IM requirements
- Important to identify container IM requirements as early as possible to minimize container design & production costs
- Research required to identify new lightweight, reduced size and reduced cost materials to prevent/mitigate SR, BI and FI reactions, but need to know the PHST environment these materials will be subject to



# TAKEAWAYS

---

- Essential to have a knowledge of PHST requirements and shipboard CONOPS to optimize container IM solutions
  - Ensure IM solutions still meet all other container performance requirements
  - Minimize impact to Fleet (ordnance handling & stowage, workload/manpower)
- Naval PHST Center is ordnance PHST COE for Navy and is available for collaboration on IM Packaging solutions
  - Part of Joint PHST Center – Co-Located at Picatinny Arsenal with Army Packaging
  - Current and Future Collaboration with Army on IM Packaging Solutions