

# BAE Systems Platforms & Services

## Commander's Independent Weapon Station Demonstrator

April 22, 2015

Dirk Jungquist  
Roger Nase



# Introduction

- This presentation provides an overview of a Commander's Independent Weapon Station (CIWS) demonstrator developed to integrate a sensor payload with a weapon system on a high precision pointing gimbal
- DRS developed the CIWS sensor payload and BAE Systems the pointing gimbal
- CIWS provides the Commander a panoramic 360° stabilized sight capable of day / night engagements with the remotely operated M240 commanders weapon, or the vehicle main gun



# CIWS System Overview

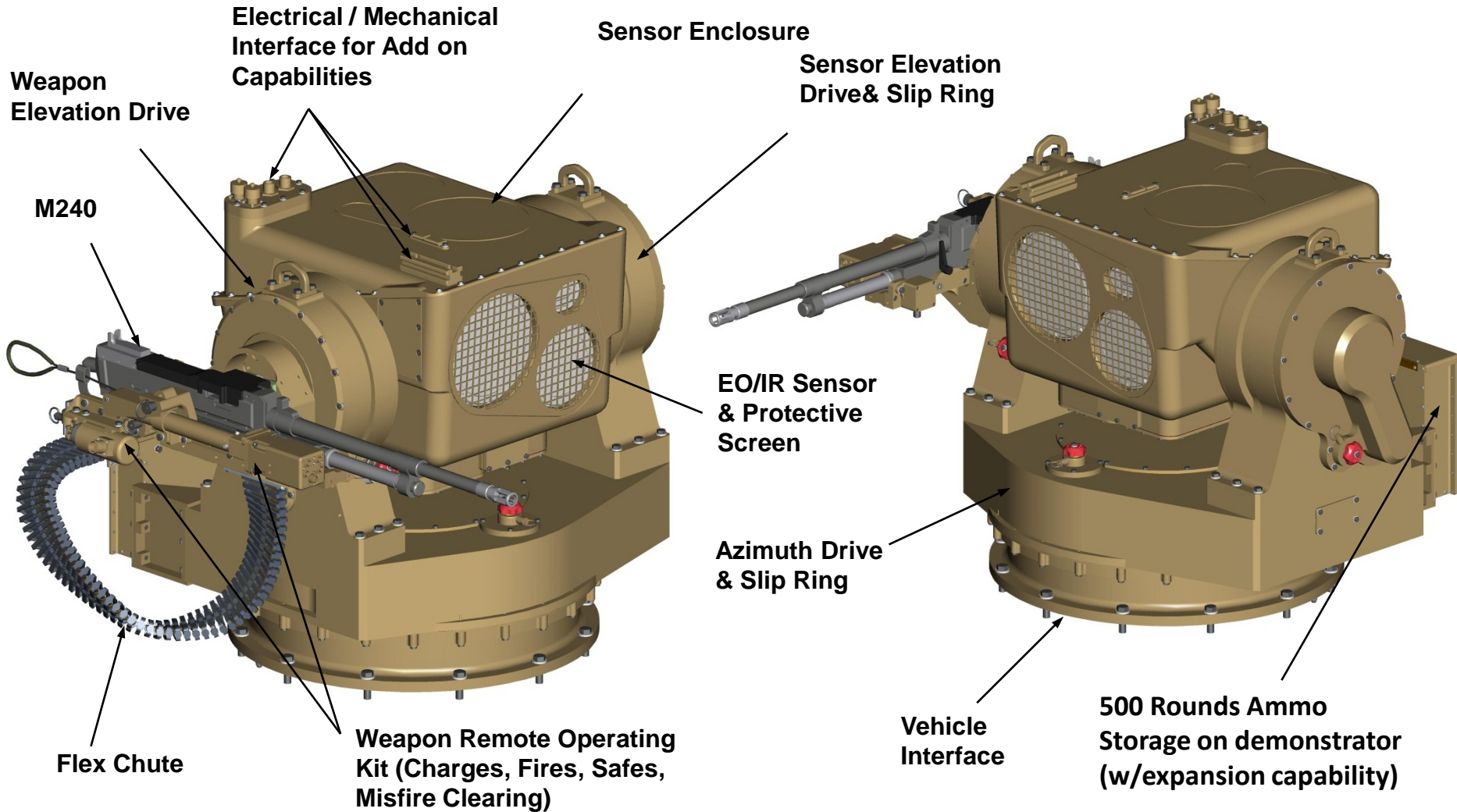

# CIWS Field of Regard

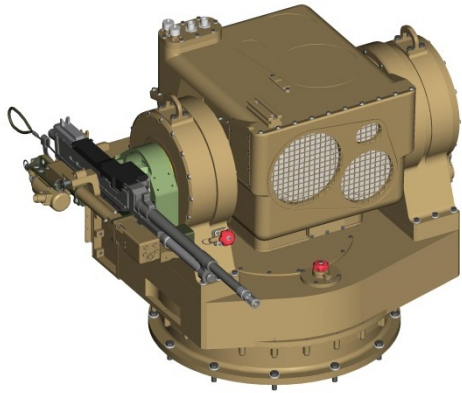

**Sight and weapon  
at 0° elevation**

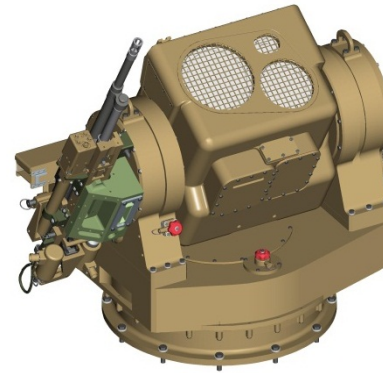

**Sight and weapon  
shown at 60° elevation**

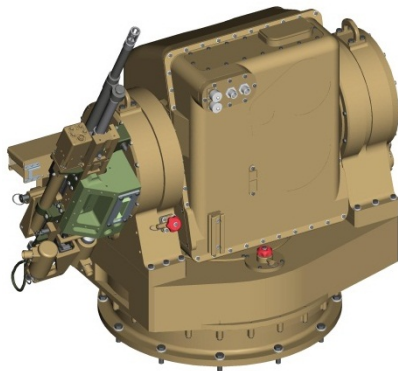

**Sight at stow to  
protect the optics**

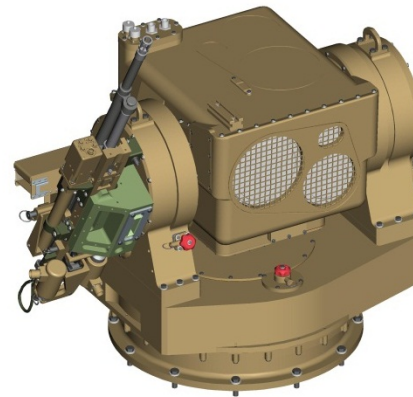

**Sight at 0° and  
Weapon at 60°  
Surveillance with  
non-threatening posture**

## CIWS Capabilities and Features

- Excellent Line of Sight (LOS) stabilization (Direct drives, rigid structure, appropriate feedback sensor suite, and control architecture)
- On-board M240 weapon platform capable of on the move precision engagements
- 2nd Generation Forward Looking Infrared (FLIR) & High Definition Color Day Camera Imagery
- Eye-safe Laser Rangefinder, Near Infrared (NIR) and Visible Laser Markers
- Non-Lethal Effects devices

## CIWS Capabilities and Features (continued)

- M240 Weapon super elevation provides ballistic range compensation without reticle shift
- M240 Lead angle compensation (Not implemented on demonstrator)
- Remote M240 weapon operation with 500-1000 ready rounds
- Redundancy to continue the fight - CIWS capable of engaging targets with main weapon
- 360° silent watch and sector scanning
- Armored sensor and structure

# Sight Only Variant

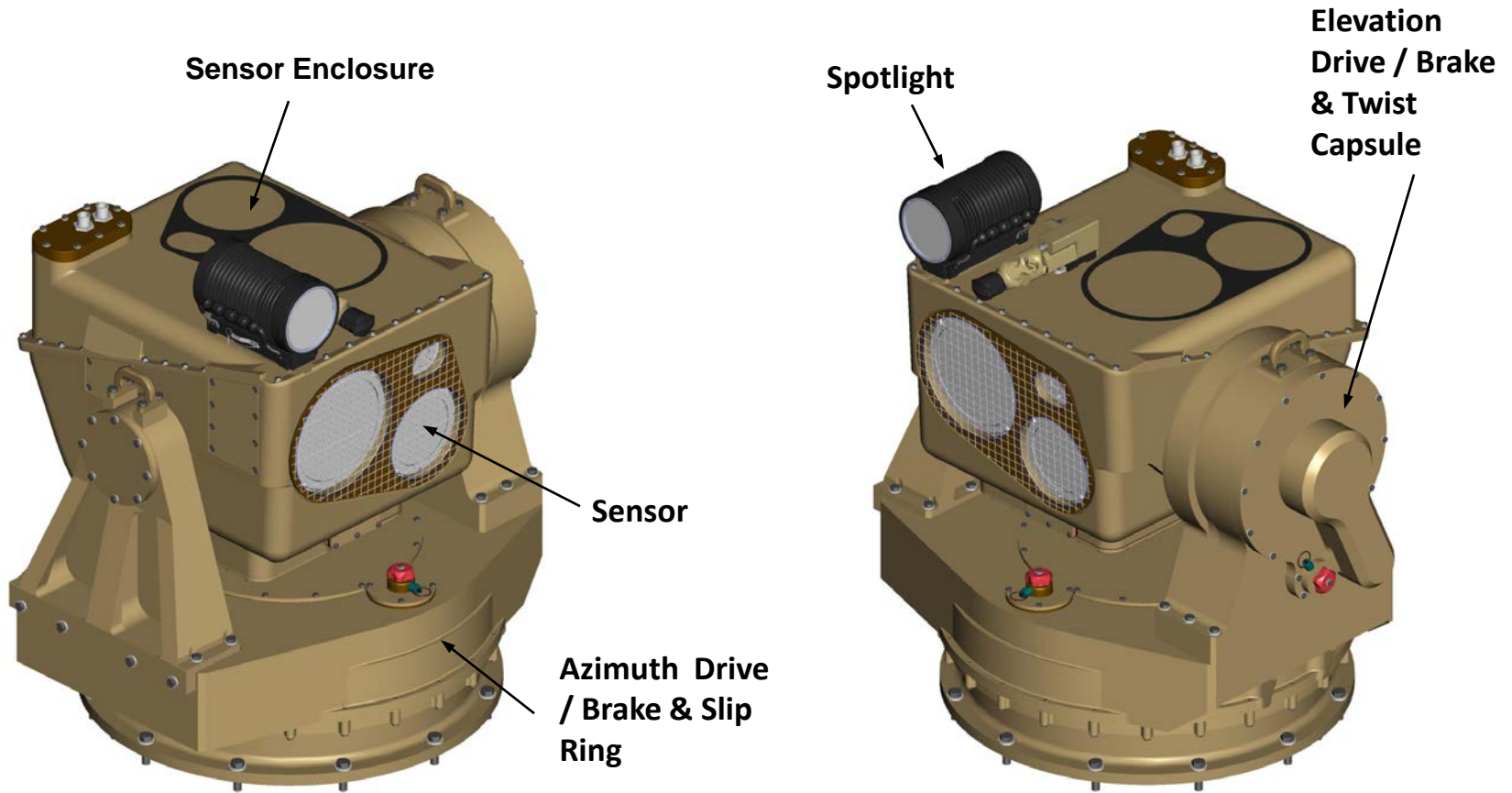

# Mobility Disturbance Pointing Validation

- Assessed gimbal stabilization performance on a 6DOF motion table programmed to provide an input disturbance profile
- Collected RMS LOS stabilization of gimbal from gyro feedback
- Collected FLIR and DVC imagery to calculate the LOS motion of a target board
- Verified operation through a representative bump-course motion profile
- Correlated simulation predictions against test results





# Camp Ripley CIWS Live Fire Testing

- All tests were completed and test goals were met
- Fired rounds in Single Shot, Burst and Continuous fire at 0°, 35°, & 60° elevation
- All ammunition system and weapon control functionality verified smooth, predictable, and reliable operation, no hang ups, misfires, or jamming
- Excellent pointing repeatability/accuracy

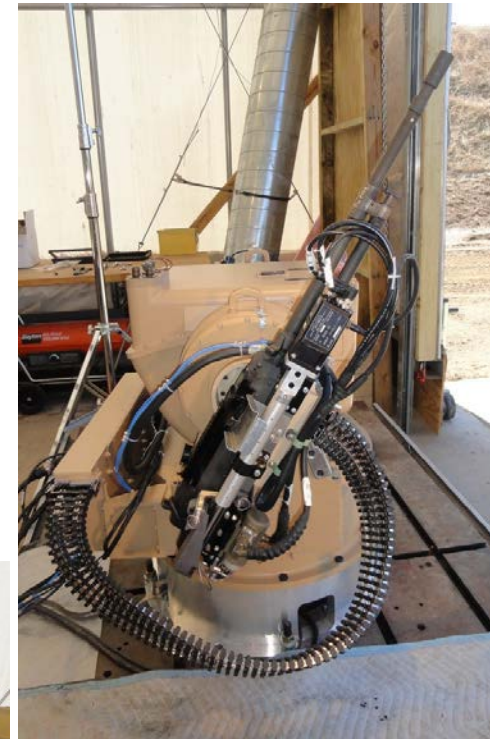

# Demonstrator Photos

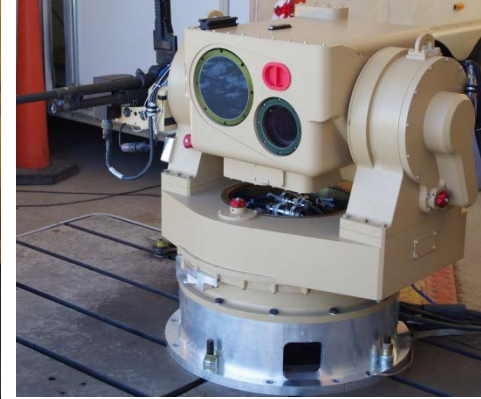
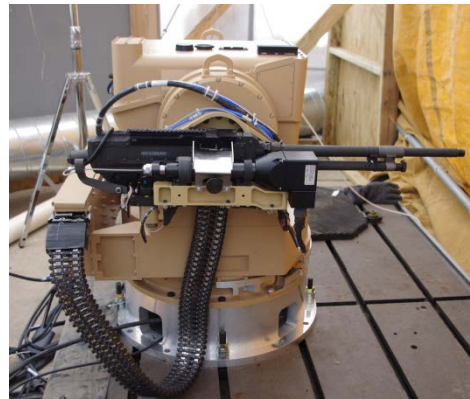
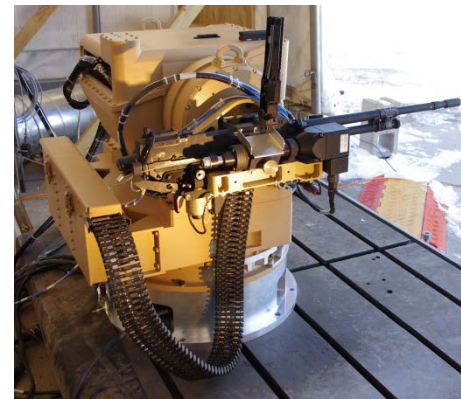
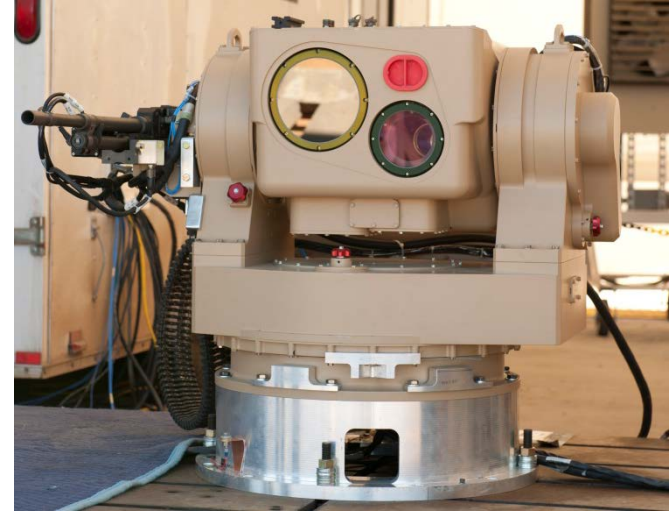
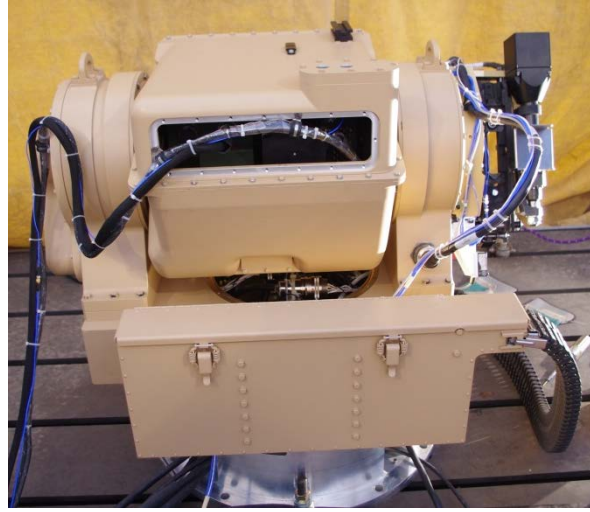
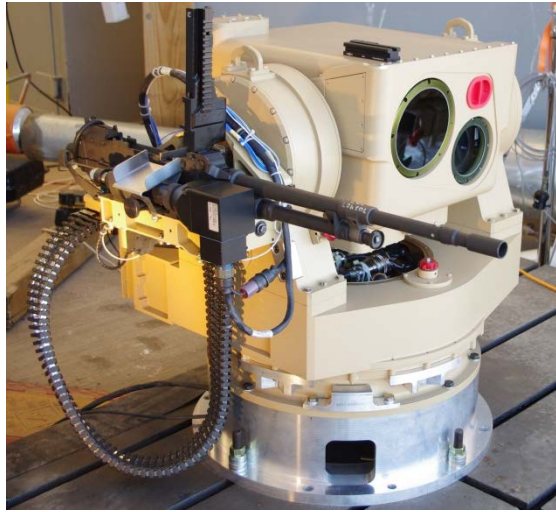

## Contact Information

---

Mr. Dirk Jungquist

Controls Technical Fellow

BAE Systems - Platforms & Services

T 763-572-5312 | F 763-572-4916 | [Dirk.Jungquist@baesystems.com](mailto:Dirk.Jungquist@baesystems.com)

4800 East River Road, Minneapolis, Minnesota USA 55421-1498

Mr. Roger Nase

Surveillance & Targeting Systems IPT Lead

BAE Systems - Platforms & Services

T 763-572-7321 | [Roger.Nase@baesystems.com](mailto:Roger.Nase@baesystems.com)

4800 East River Road, Minneapolis, Minnesota USA 55421-1498