

Development of an in-line EFI Ignition Safety Device (ISD) for Fuzing of Solid Fuel Motors

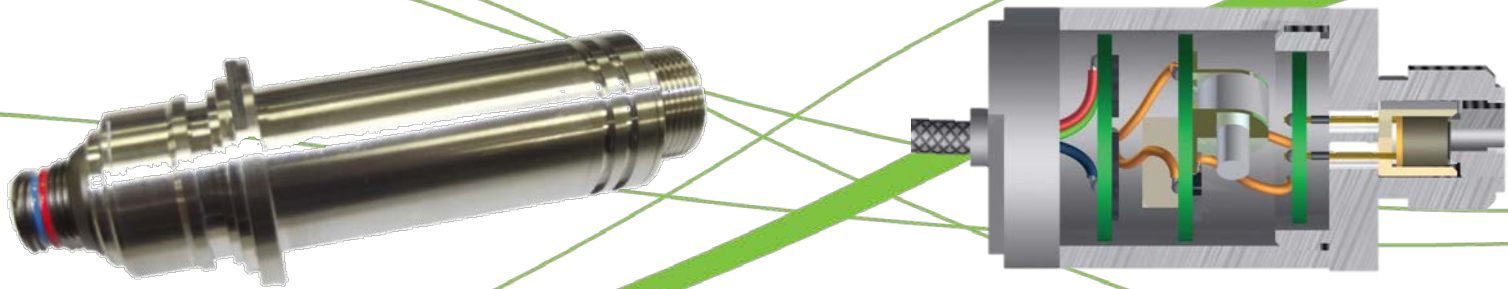

Contact Information



e2v technologies (UK) Ltd
168 Sadler Road
Lincoln LN6 3RS
United Kingdom

Tel +44 1522 500815

Dick Seddon dick.seddon@e2v.com
Brion Weller brion.weller@e2v.com
Simon Bower simon.bower@e2v.com
Graham Cook graham.cook@e2v.com

e2v Electronic Safety & Initiation

- e2v has been involved in Electronic Initiation since 1984, beginning with e2v funding of **Exploding Foil Initiator** technology development concentrating on
 - EFI research and characterisation
 - Explosive material characterisation
 - Firing circuit development for **Electronic Safety** and **Arming** applications
- e2v supply **Electronic Safety & Arming Units** and **electronic Ignition Safety Devices** to weapon systems for Air and Surface launched Missiles
- Also ESAUs for underwater applications including
 - Torpedoes
 - Underwater EOD systems



Introduction

- Many current solid fuel motor ignitors rely on Through Bulkhead Initiators (TBI) and a mechanical shutter or explosive/TBI combination to ensure safety
- Size and mass penalty with these systems
- Removal of the mechanical shutter would require robust Safety and Arming electronics architecture
- But would shorten Arming/Firing timeline and reduce size and mass
- Proven Safety and Arming electronics exists on modern explosive warhead detonators in systems which use an EFI
- Question; Can energetic material be reliably initiated by an EFI-type structure?
- If so, an EFI-based igniter for pyrotechnic materials becomes possible.

EFI based direct Ignition Safety Device



- EFI structure can be modified to produce reliable direct ignition of BKNO₃ pyrotechnic
- Enables development of a direct-ignition Electronic Ignition Safety Device
- Inherent insensitivity of the EFI bridge structure to electrical stimulus is maintained
- Physical separation of an electrically activated element from the energetic composition
- Elimination of explosive material from established through bulk-head initiator configuration (simplification of energetic chain)
- No moving parts
- No mechanical shock during ignition



EFI ISD Typical Design Overview

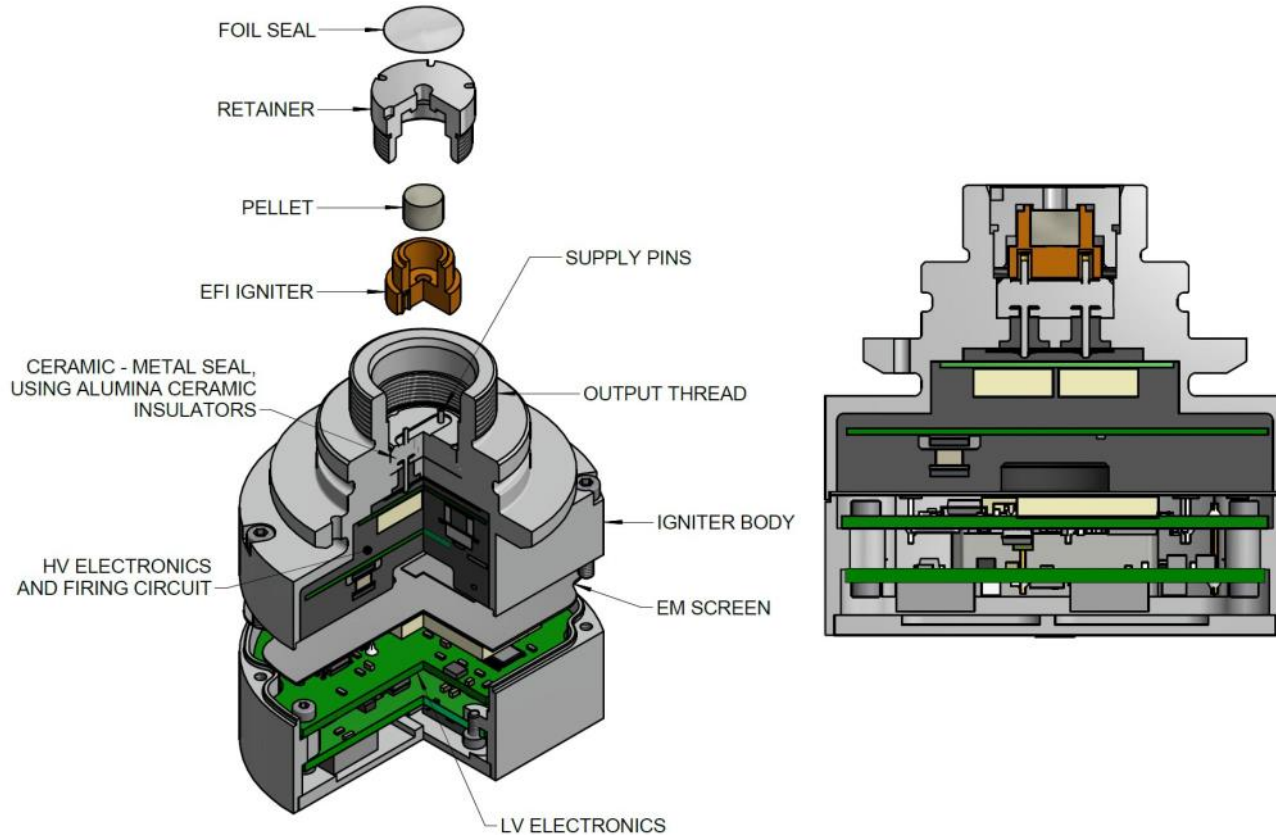

- Typical design shown
- EFI initiated
- Pyrotechnic output
- Integral Safety electronics
- Integral HV circuitry
- Automatic charging and firing after removal of SF2

Key Feature; EFI initiator



- Copper-insulator laminate structure
- Copper layer narrows to localised 'EFI bridge'
- Based on proven detonator EFI technology
- Flyer layer separates pyrotechnic from electronic system
- Fast-rising current explosively bursts bridge
- Pyrotechnic initiates producing flame and particulate output

Pyrotechnic pellet



Lateral view of EFI burst , 25ns exposure, 250ns between frames

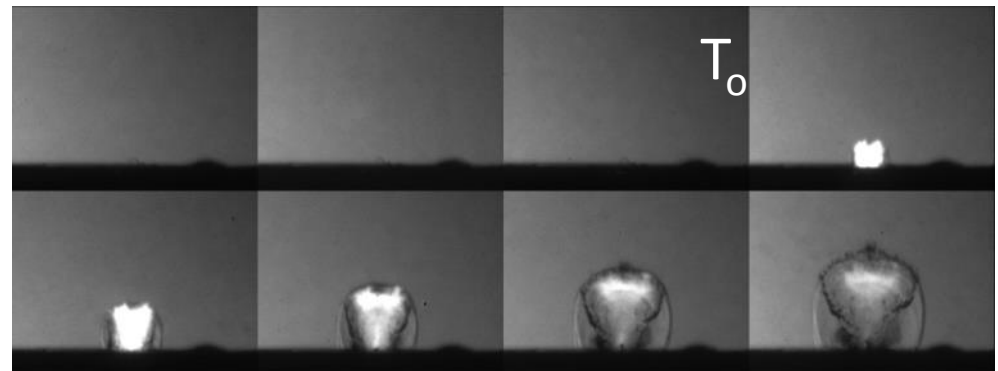

Key Feature; Pyrotechnic Pellet

- Pressed mixture of Boron and KNO_3
- Good mechanical integrity
- Life and ageing data suggests pellet is physically stable
- 250mg minimum, 5.2mm long, 6.35mm diameter
- Plain barrel shape
- Output pressure of 25-50 bar into 20cc volume

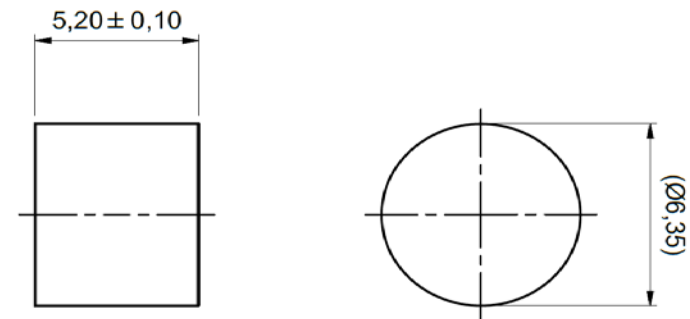

Key Feature; Safety and Arming Electronics

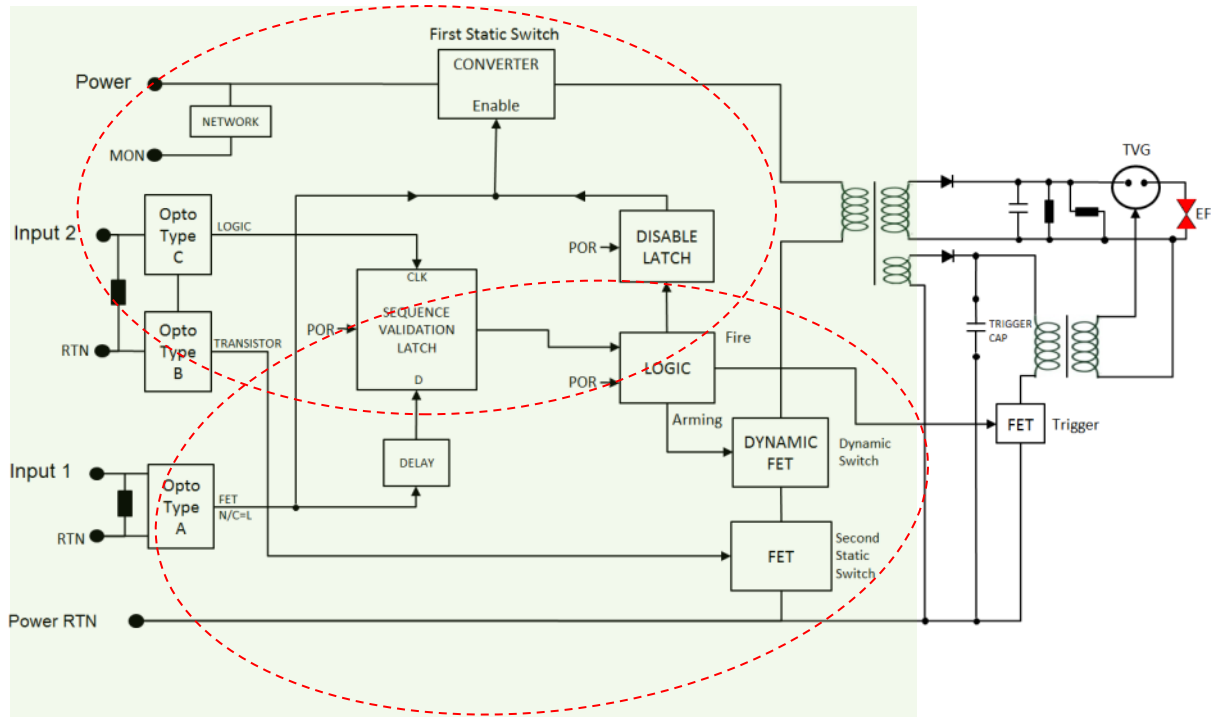

- Two safety features, three energy breaks
- One dynamic break, two static breaks
- S1, S2 and dynamic breaks are different components
- Independent control of breaks
- Galvanic isolation between power and inputs
- Three different technology opto-isolators
- Removal of supply, input 1 or input 2 will return unit to unarmed state

Key Feature; HV PSU and Firing Circuit

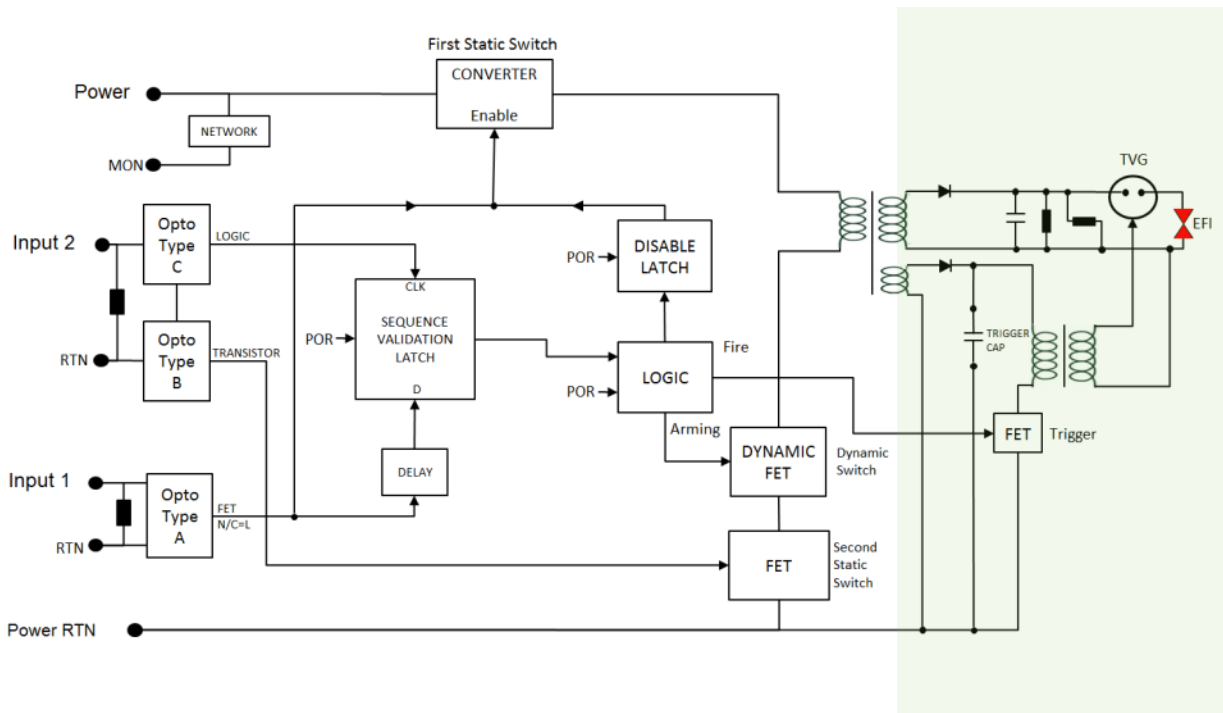

- Ferrite-cored transformer
- 'Flyback' HV PSU
- Ceramic firing capacitor
- TVG switch
- Firing pulse generated at pre-determined charging voltage (Automatic Firing)

EFI ISD Key Features - Summary

- Internal seal maintains motor pressure vessel to greater than 300bar backpressure
- Electrical isolation exists between firing circuitry and the pyrotechnic pellet (due to EFI cover-layer)
- Three energy breaks combine to provide two independent safety features
- Provides detonator type Safety & Arming capability compliant to STANAG 4368, & MIL-STD 1316
- No explosive content therefore no mechanical shock
- Prompt Arm and Fire operation, firing energy is not stored prior to operation
- Initiation occurs promptly after removal of second safety feature
- EFI-type structure initiates pellet to provide flame and particulate
- Standard BKNO₃ pyrotechnic material is used



Output pressure-time performance

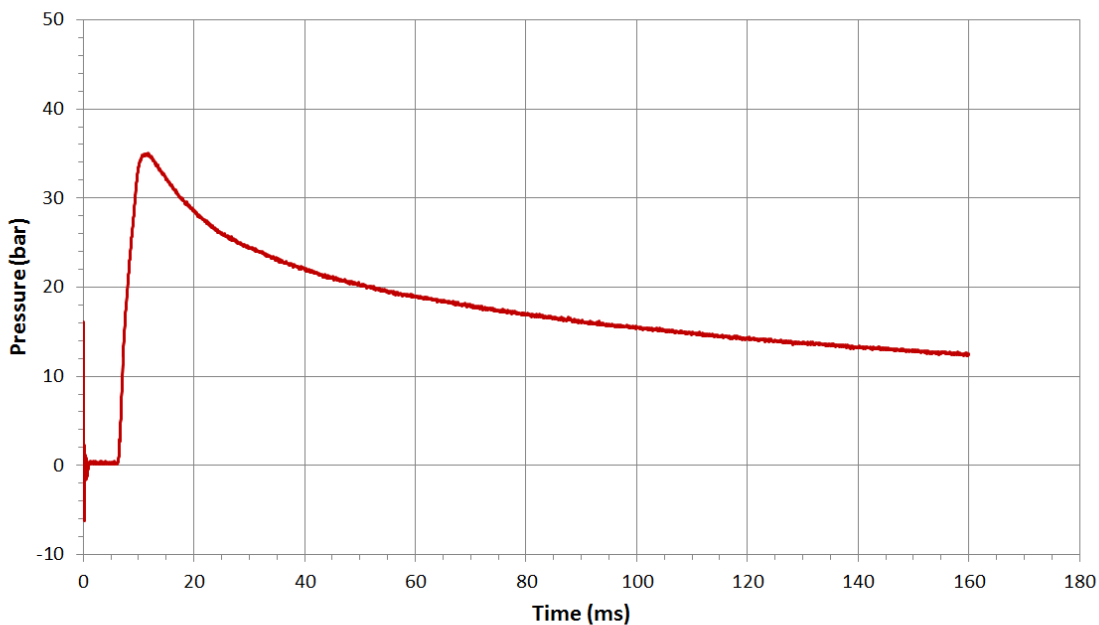

- Typical output pressure-time curve shown
- Output peak pressure of 35bar typical into 20cc volume
- -55°C/+85°C operating temperature range
- Risetime to peak pressure of 10ms typical
- Minimum energy output of 1200J

Output pressure-time performance

- Pressure / time profile Test at -55°C into 20cc volume.
- Typical spread 32-40bar peak, 9-15ms time to peak

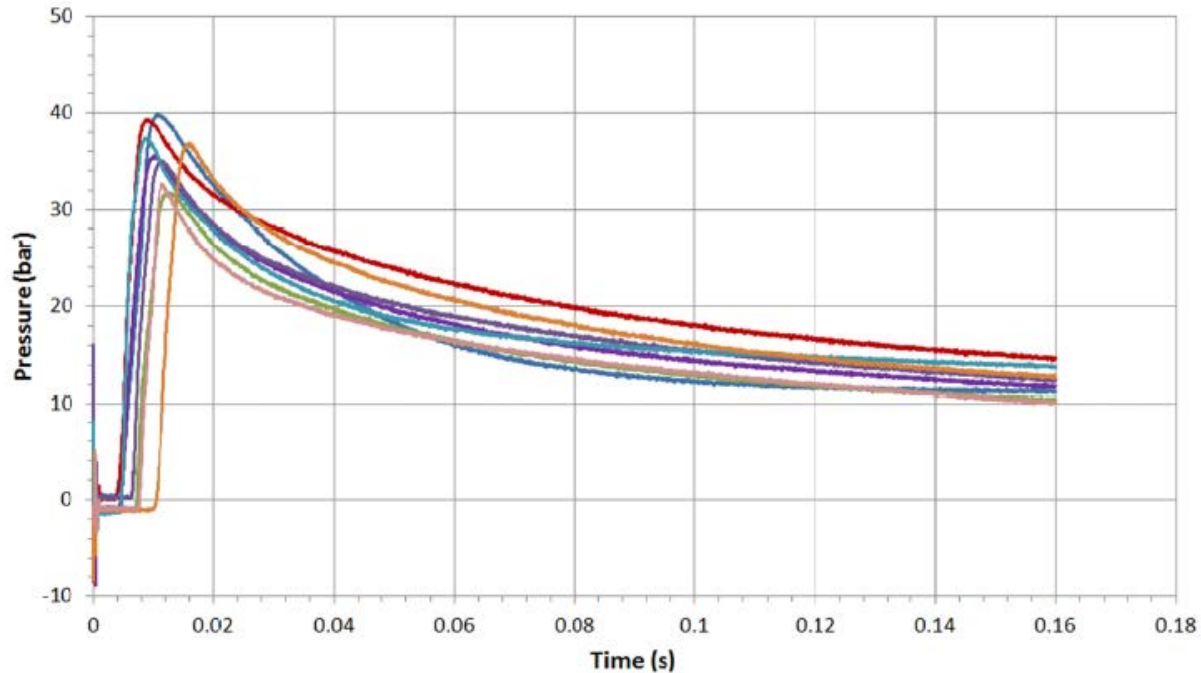

Typical timing diagram

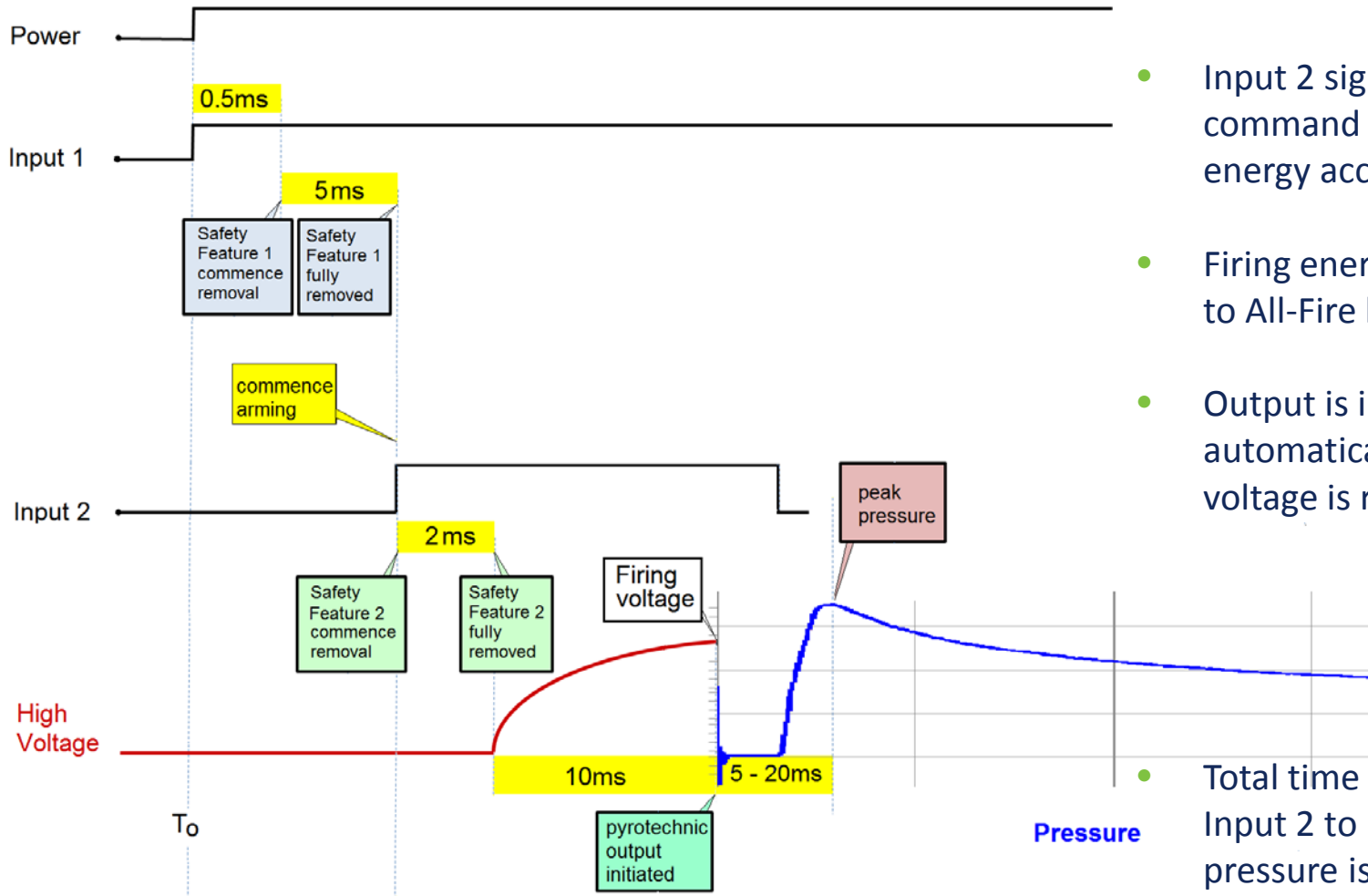

- Power and Input 1 applied simultaneously
- Input 2 signal is 'Fire' command and enables firing energy accumulation to begin
- Firing energy is accumulated to All-Fire level plus a margin
- Output is initiated automatically once the Firing voltage is reached

- Total time from application of Input 2 to peak output pressure is in range 17-32ms

EFI ISD Validation

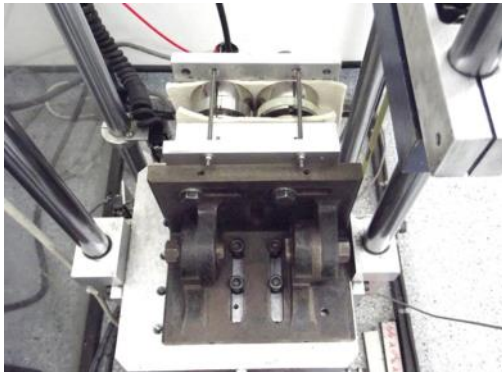
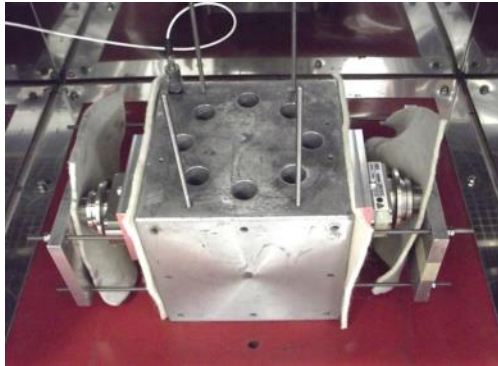

- Environmental capability
 - Vibration to Def Stan 00-35
 - Operational , transport profiles
 - 10s hours per profile, all axes
- Mechanical shock
 - 100g, 6ms, trapezoidal
- Thermal shock
 - -55°C/+100°C, 20°C/min, 200 cycles
- Thermal cycling
 - Def Stan 00-35 A1 profile
- Humidity
 - Def Stan 00-35, Chapter 3-13
- All test samples operational to test requirements at conclusion of environmental tests

Conclusions

- The design and performance of an EFI-based Ignition Safety Device (ISD) has been outlined
- The ISD uses an EFI structure to directly ignite BKNO_3 and has no moving parts
- The ISD does not use explosive and does not generate a prompt shock when operated
- An internal seal maintains the rocket motor pressure vessel envelope
- Electrical isolation between the firing circuitry and the BKNO_3 pellet is maintained by an internal insulating layer
- Three energy breaks combine to provide two independent safety features
- Provides detonator type Safety & Arming capability compliant to STANAG 4368, & MIL-STD 1316
- Environmental proving has been completed to typical military platform environments
- Prompt Arm and Fire operation after removal of second safety feature, firing energy is not stored prior to 'Fire' command
- Peak output pressure is typically 35 bar across military temperature ranges and is generated typically 20ms after the 'Fire' command is issued



Electronic Safety & Initiation (ES&I)

e2v designs, develops, qualifies and produces in-line electronic safety, arming and initiation solutions for high-explosive Effectors and solid propellant Motors on missile and torpedo sub-systems

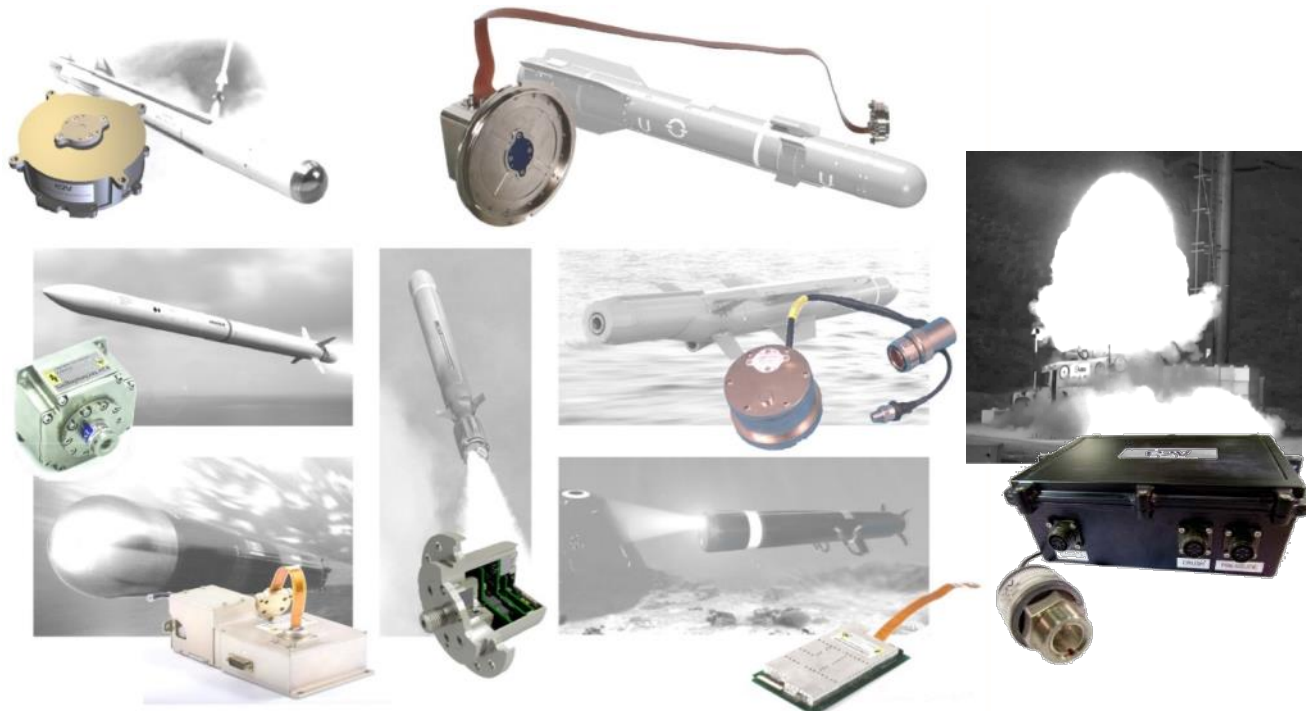

Safety, Arming
& Firing Unit

Ignition Safety
Device (ISD)

Active Protection
Sub-Systems