



# DoD MEMS Fuze Reliability Evaluation

59<sup>th</sup> Annual NDIA Fuze Conference, Charleston, SC  
Thursday, May 5<sup>th</sup> 2016, Open Session IVA, 10:20

Taylor T. Young  
NSWC IHEODTD  
301-744-1103  
Taylor.T.Young@navy.mil

Jeffrey Smyth  
U.S. Army ARDEC Picatinny Arsenal  
RDAR-MEF-F Fuze Division  
Jeffrey.R.Smyth.civ@army.mil

# MEMS Safe and Arm

- MEMS S&A offers the potential for small volume, low cost, and low energy.
- NSWC IHEODTD has nearly two decades of silicon/SOI MEMS design, fabrication, and packaging experience.
- Safety locks: integrated micromachined and command release architectures
- Arming: Environmentally derived and command architectures
- All non-explosive components fabricated on SOI wafers using established semiconductor processes.

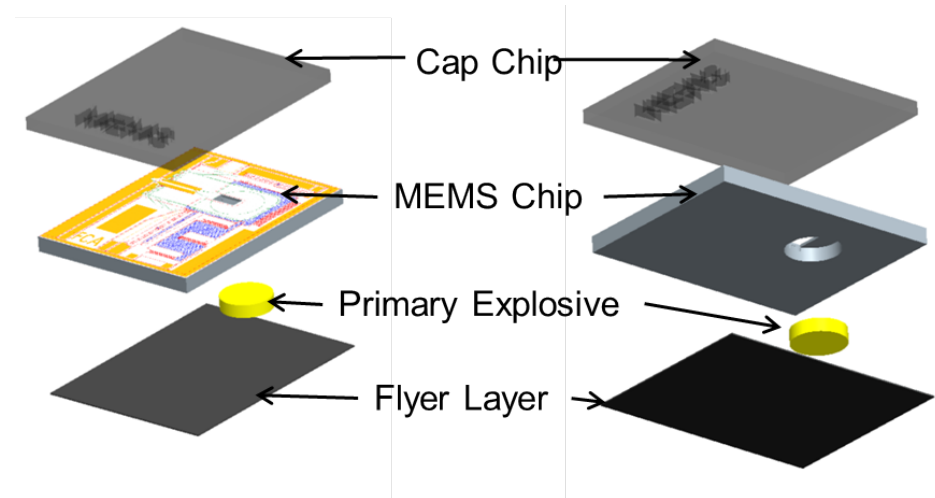
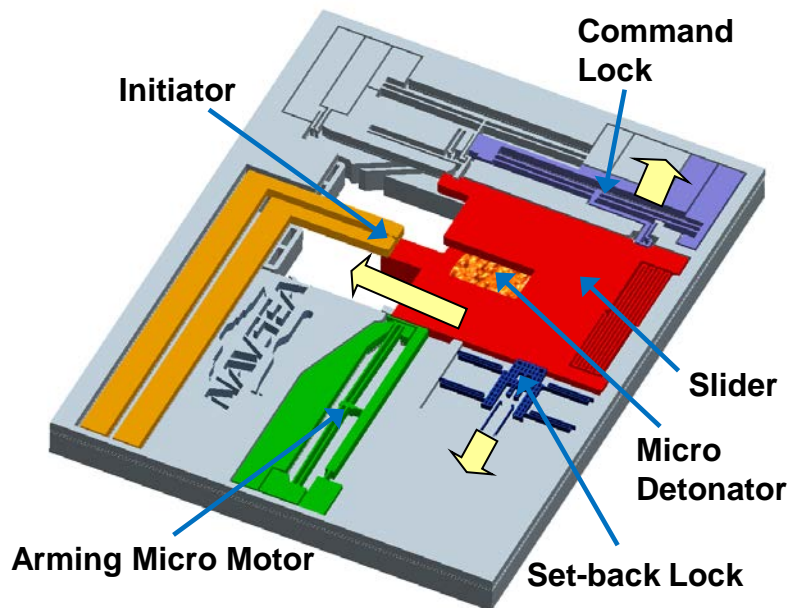

# MEMS Applications

40 mm Grenade



Hypervelocity Projectile

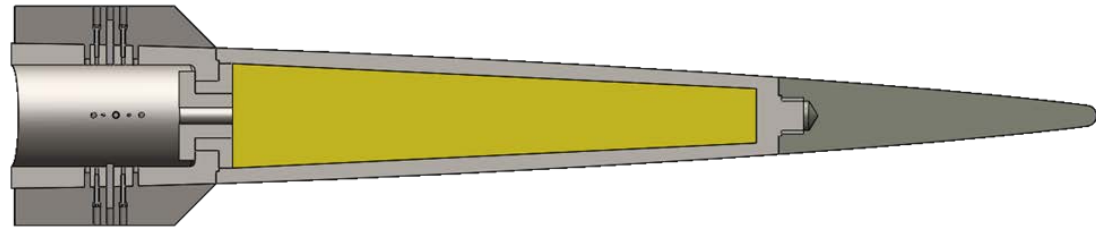

High Reliability DPICMS Replacement (HRDR)

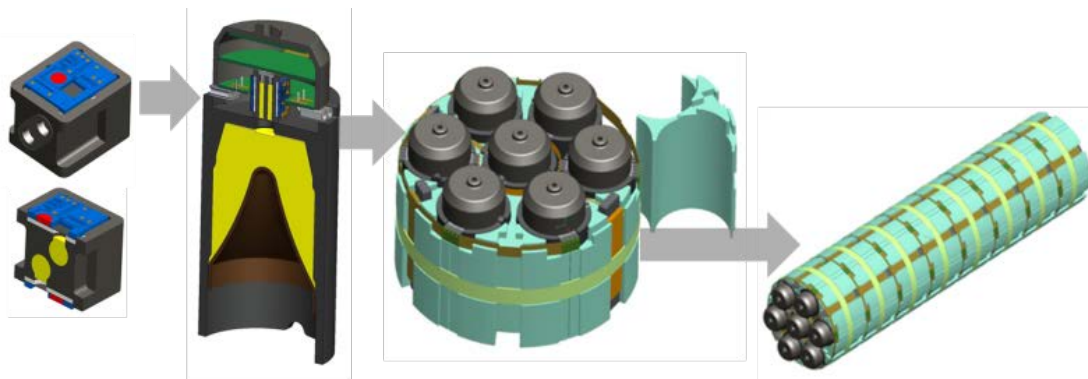

Flight Controlled Mortar



# Explosive Train Reliability

- MEMS intentionally pushes the lower limits of explosive component size. We want the smallest size detonators and leads that will work reliably.
- Target programs have strict reliability requirements. This is particularly true for HRDR which must comply with OSD's policy of  $<1\%$  UXO for cluster munitions.



# Explosive Train Overview

- Studying the explosive trains of both the Navy and Army MEMS Fuze
- Both designs have been demonstrated to TRL6
- Navy Design
  - Vaporizing metal foil bridge initiator fabricated onto the cap chip
  - Pressed silver azide pellet assembled with the MEMS S&A chip drives a flyer to initiate an explosive ink output lead
  - Lead make 90° turn and initiates a booster
- Army Design
  - Metal foil bridge
  - Deposited energetic ink drives small flyer into explosive ink transfer charge
  - Transfer charge makes 2 90 ° turns and initiates output lead

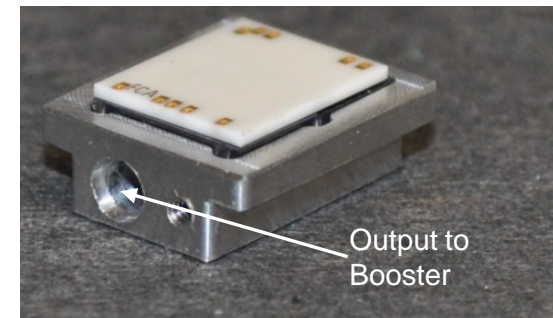
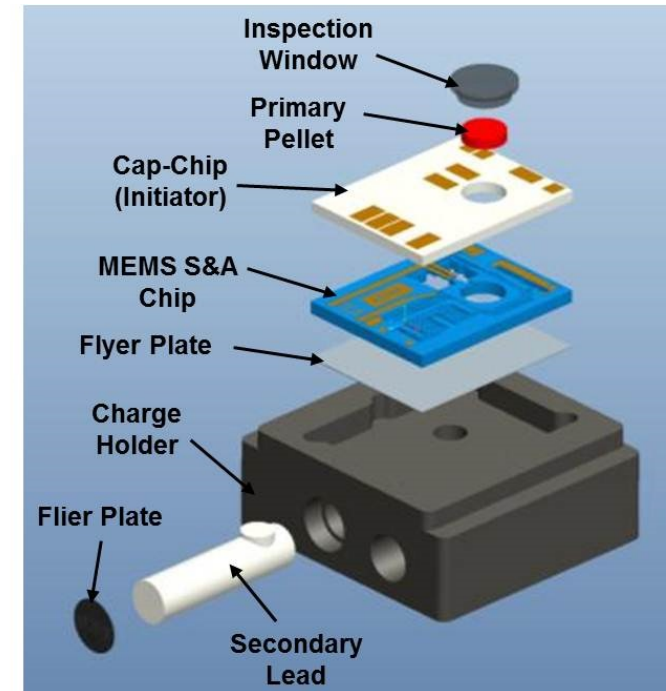

μDetonator Package

# Navy Explosive Train (Basics)

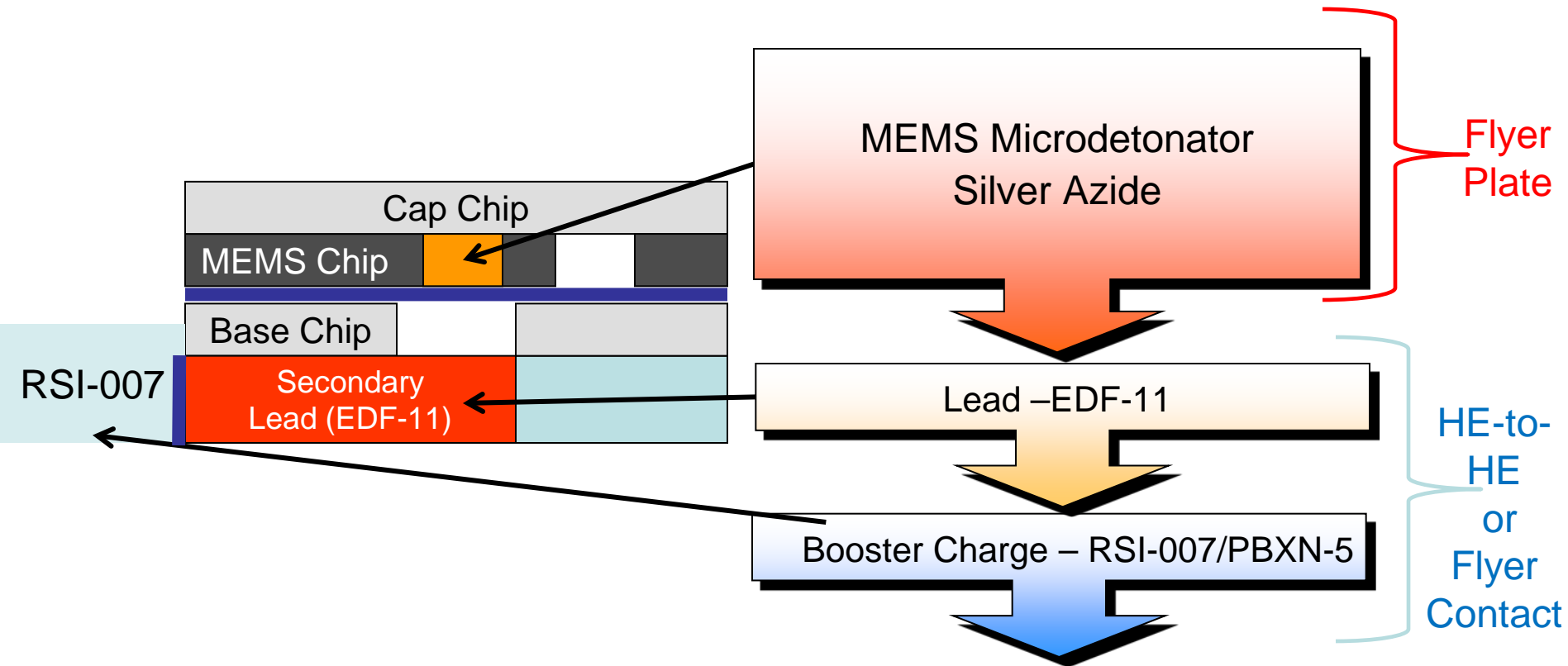

# Army Explosive Train (Basics)

US Army AREDEC also has a MEMS Fuze effort.

Uses LIGA metal MEMS processes.

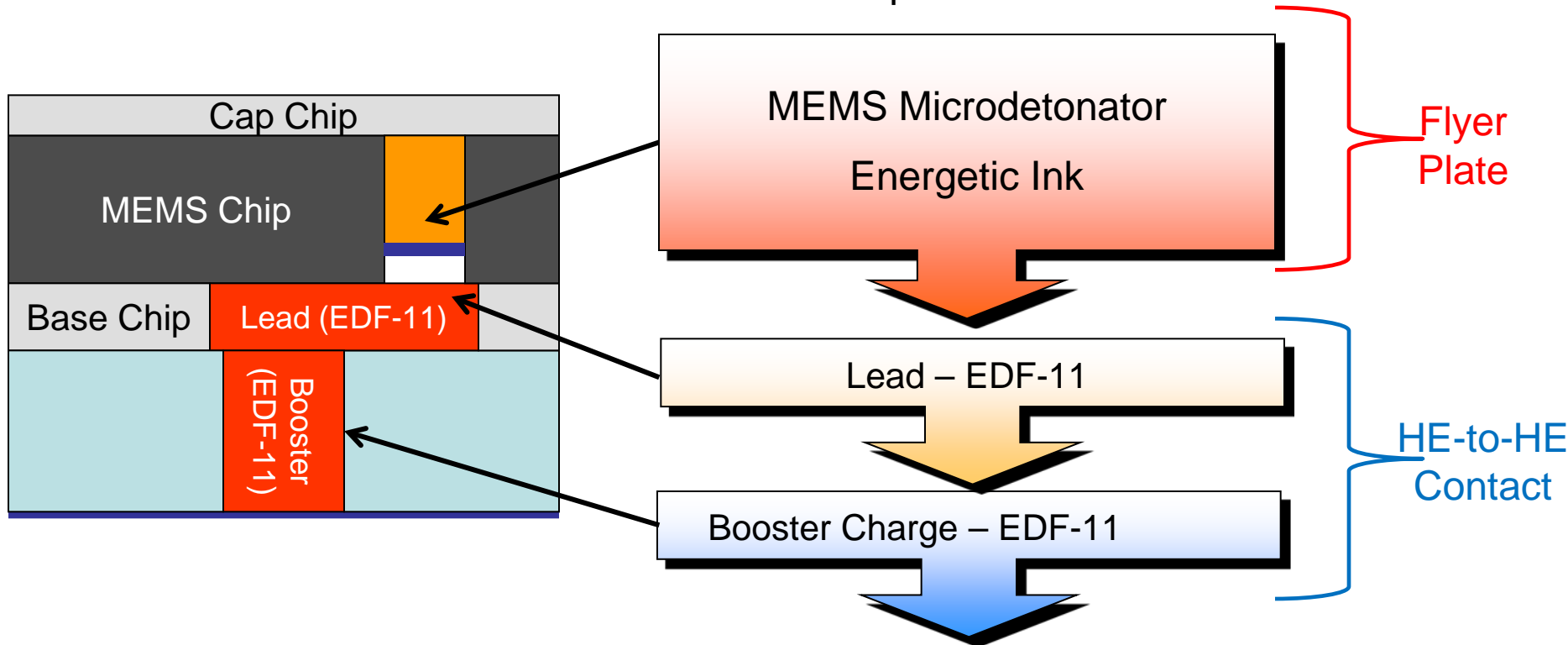

Both detonators use stainless steel flyer plates

# Brute force methods

Brute force demonstrations requires excessive number of shots to prove reliability.

99.9% Reliability @ 95% CL: 3000 Shots

Binomial Reliability at 95% Confidence Level (one sided)

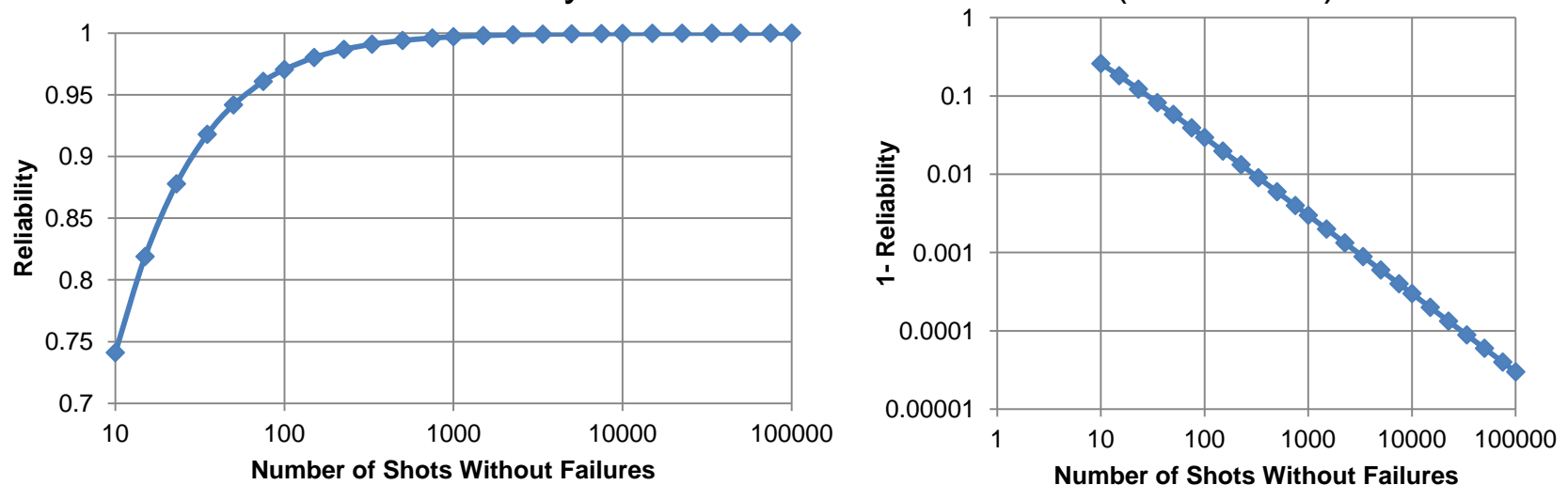

100 shot test series only demonstrates reliability to 97% (@ 95% CL)

Extremely expensive and becomes impractical for an evolving design



# Background – Probabilistic Hugh James Space

Hugh James formalism can be used to map out statistical response of acceptor explosive

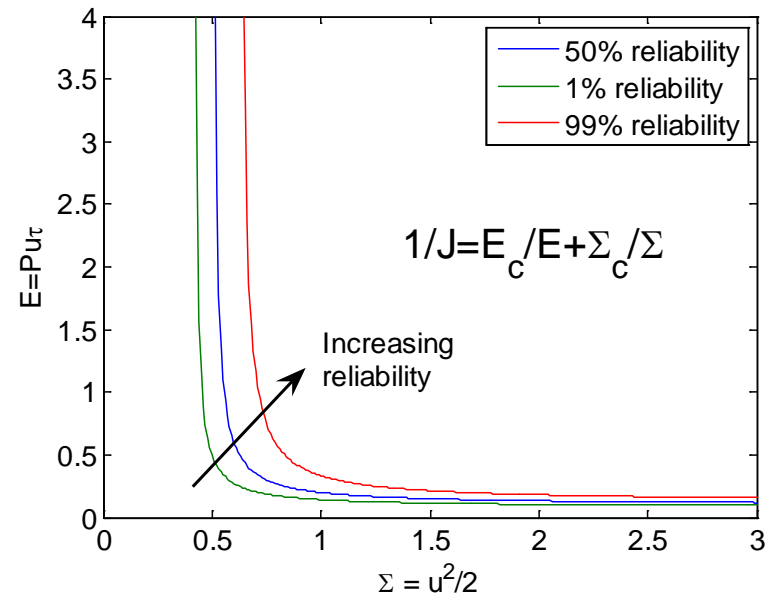
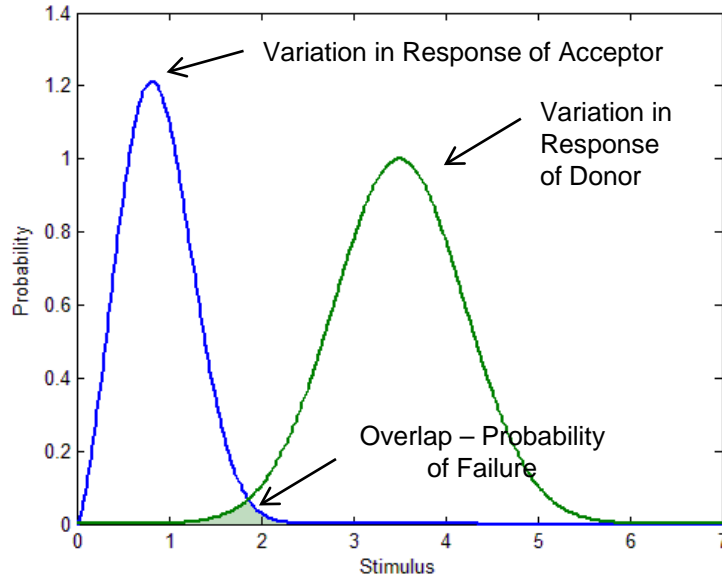

$E_c$  (critical minimum energy) &  $\Sigma_c$  (critical minimum 'power') are defined by the acceptor explosive material.  $E$  &  $\Sigma$  can be calculated from variable flyer and gap tests and inherent explosive properties.

Data can better be used to evaluate a family of similar designs, provide more insight into the system and can be used to optimize designs

These methods were developed at AWE and LLNL and implemented at AFRL.

# Detonator Characterization

MEMS flyer velocities can be measured with PDV

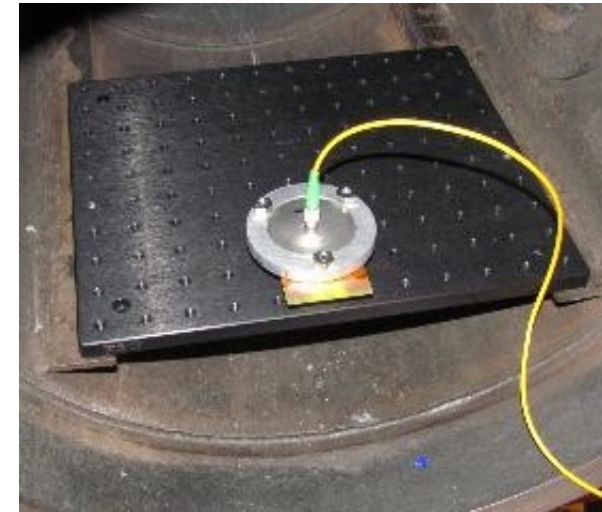
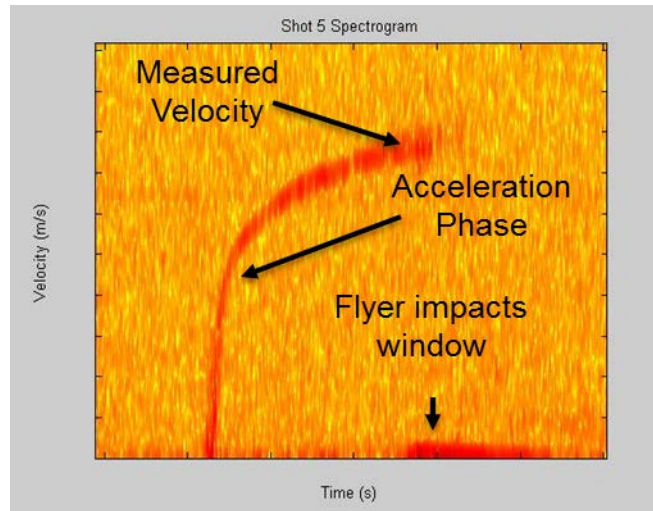
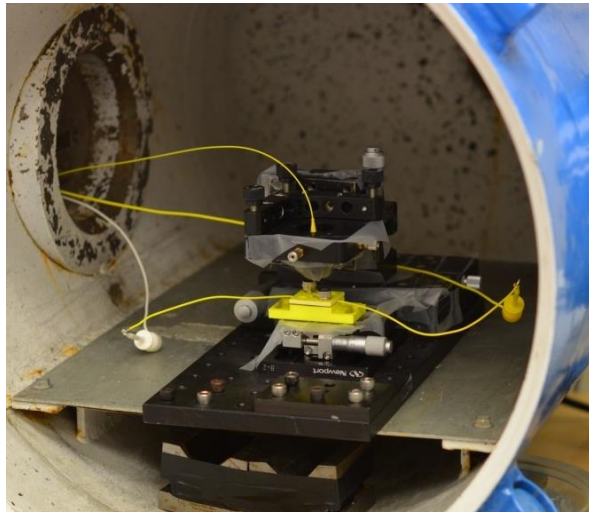

Variability will be present in any system → Need to shoot a sufficient number (100+) to fit to a statistical distribution.

Exact number of shots needed depends on how quickly tails of distribution die off.

PDV system can also be used to measure pressure time histories for contact detonation interfaces.

# PDV Results - Navy

48 shots analyzed to date. Additional shots ongoing.

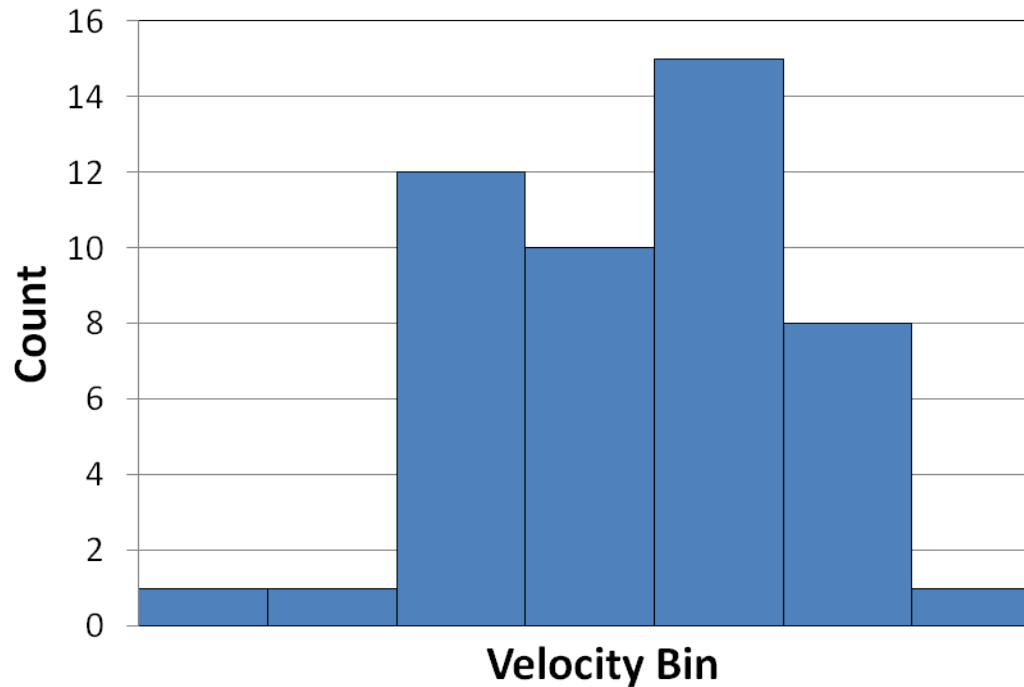

Standard deviation 3.7% of mean value.

# Flyer Measurements in HJ Space

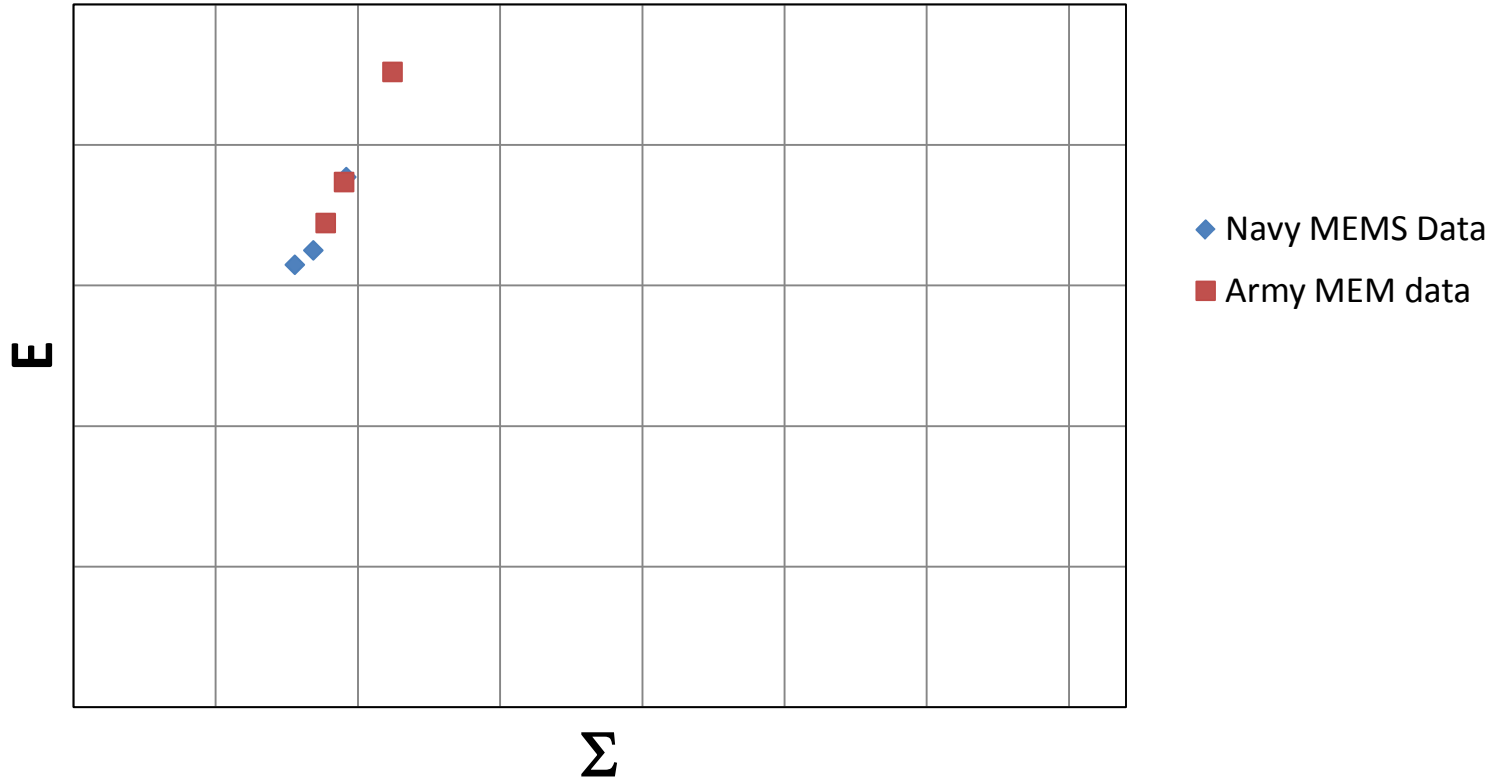

The Navy design uses a larger diameter flyer

# Previous EDF-11 Threshold Measurements

LLNL has made previous threshold measurements on EDF-11

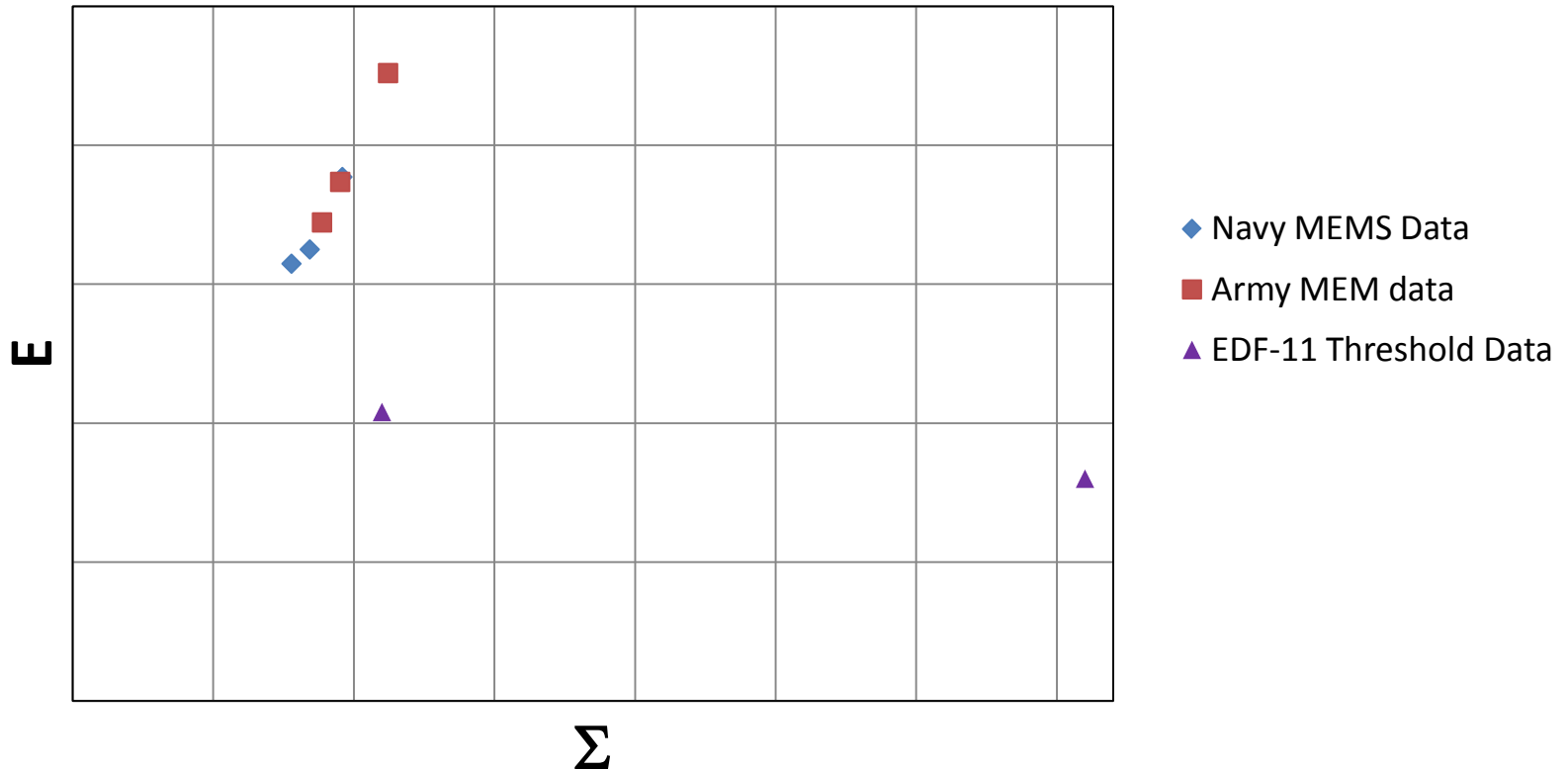

These measurements were made at EFI length scales, and would be lower at larger spot sizes.

# Fit ill-defined

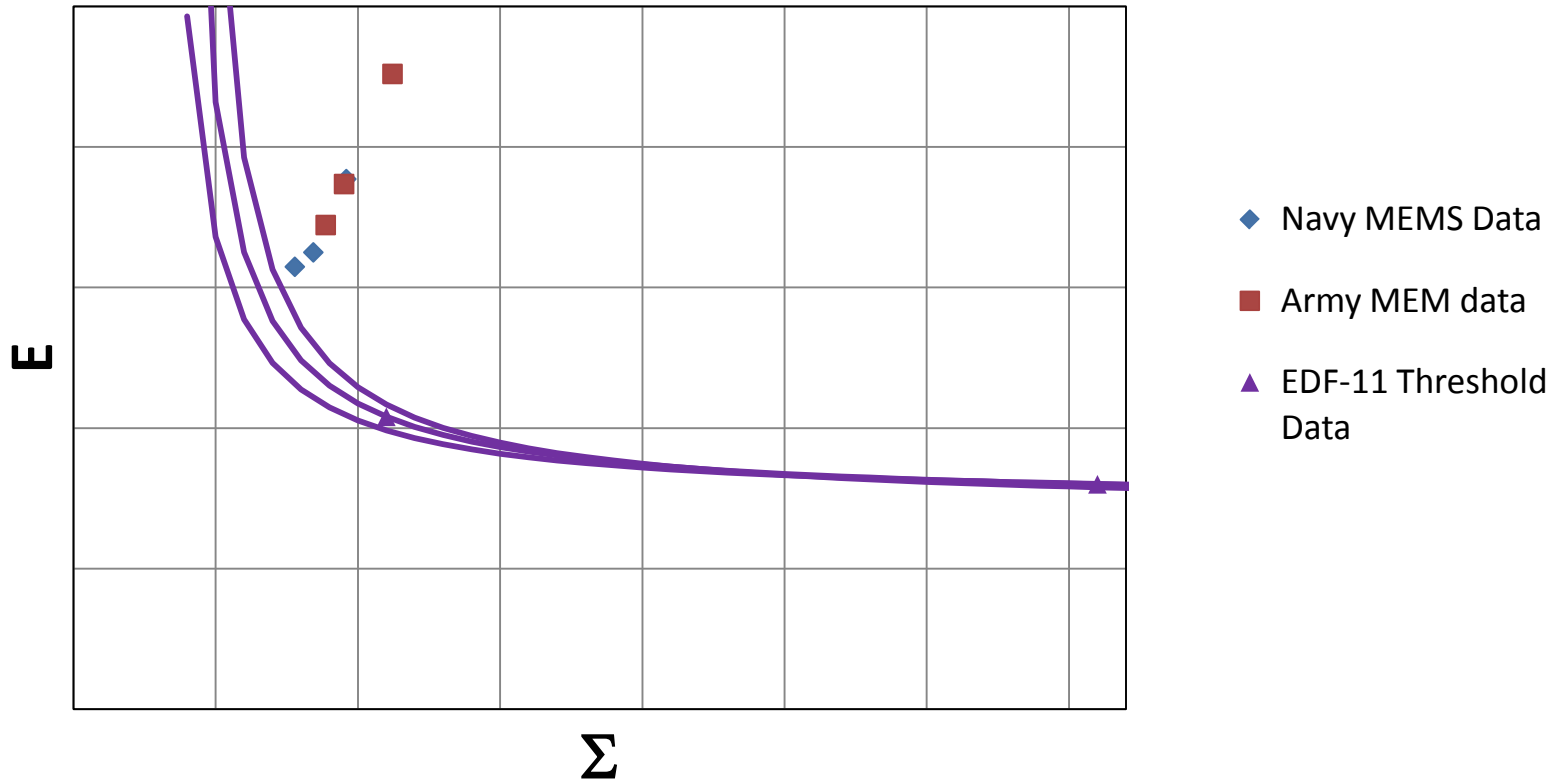

These two points do not well define a hyperbolic fit.

# Proposed Measurement Paths

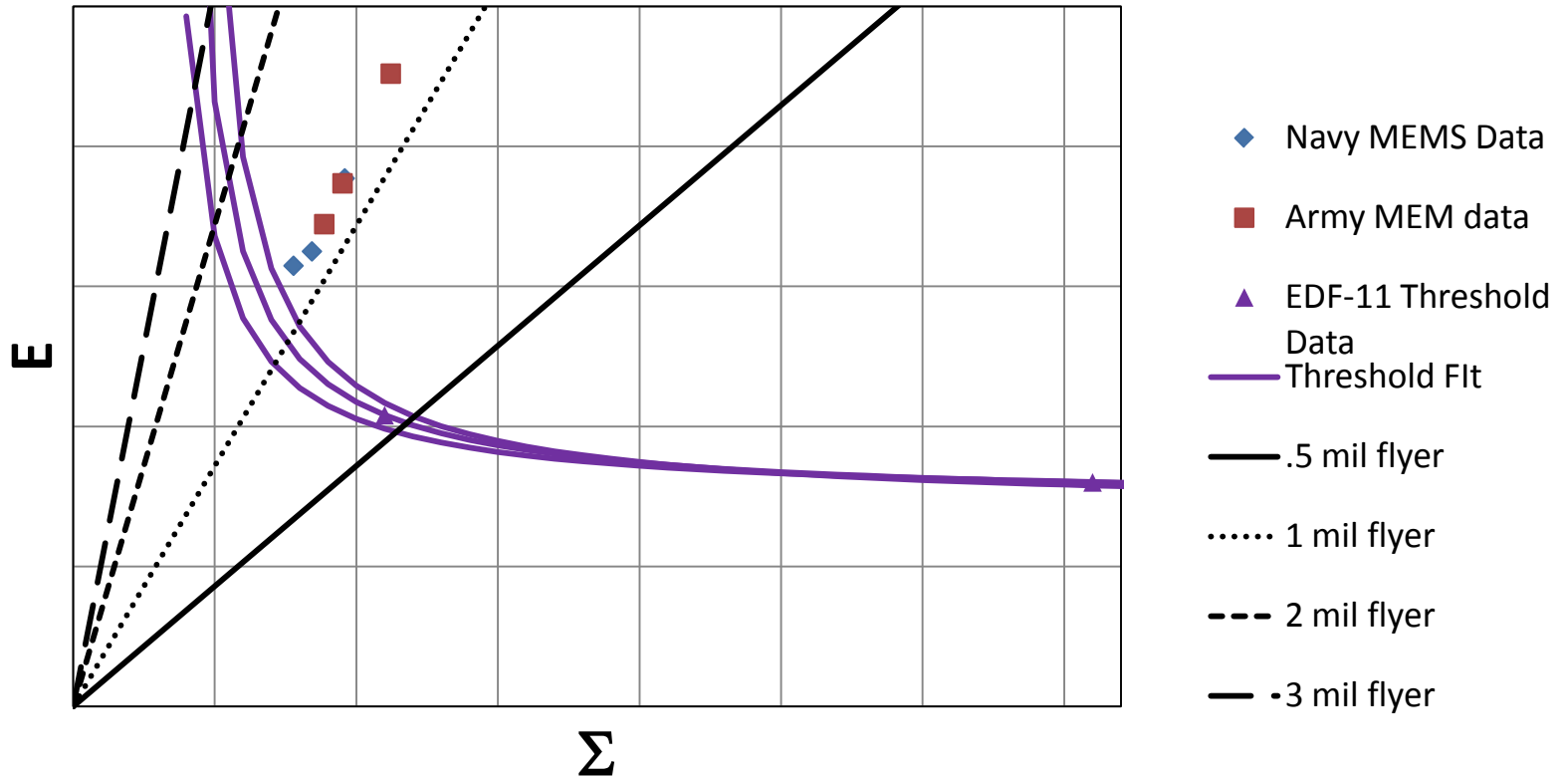

Each flyer thickness defines a path through HJ space.

# EDF-11 HJ Parameterization

- Electric gun will be used to make EDF-11 sensitivity measurements.
- Conduct threshold testing at several flyer thicknesses and a representative flyer dimension
- Limited number of previous measurements at EFI relevant length scales, but spot size dependent.

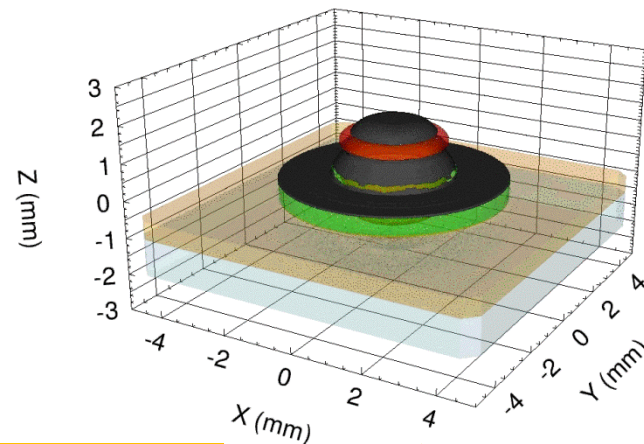

Need to have Hugh James Initiation data at MEMS scales





# Upcoming

- Finish detonator experiments and fit distribution function
- Multiple threshold test series of EDF-11 in a MEMS relevant Hugh James Space
  - 0.5, 1, 2, and 3 mil thick Kapton
- Transfer lead output test series
  - PDV measurements of lead output
- Compile Navy and Army data, map into generated James space and estimate system reliabilities

# Conclusions

- New explosive trains require new methods of analysis.
- These new methods can better aid intelligent design.
- We are utilizing a new method to quantify the reliability of small explosive trains with a reasonable number of asset firings.
- Both the Navy and Army are committed to ensuring that MEMS fuzing achieves the highest degrees of reliability possible.

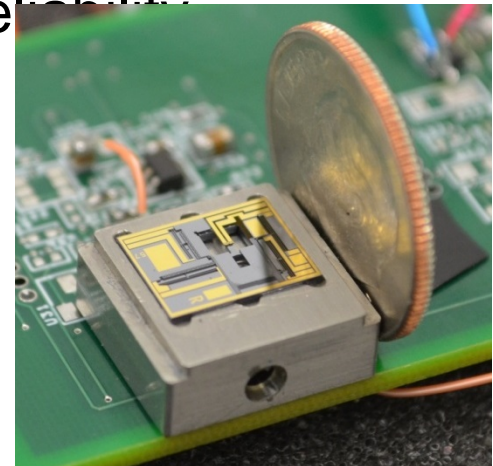



# Acknowledgments Section:

Thanks to the Joint Fuze Technology Program (JFTP) for funding this work.

Thanks to Chadd May and Lawrence Livermore National Labs (LLNL) for the loan of the electric gun.

Thanks to Eric Welle and the Air Force Research Laboratory for Hugh James implementation support.

Thanks to those who have helped work on the project:

NSWC IHEODTD  
Daniel Lanterman  
G. Shane Rolfe  
Jason Brindle  
Daniel Pines

ARDEC  
Roger Cornell  
Daniel Stec  
Charlie Robinson  
Brian Fuchs



# Questions?