

# ***Headquarters U.S. Air Force***

---

*Integrity - Service - Excellence*

## **NDIA Systems**

### **Engineering Conference**

**Line of Action (LOA) 2 Action Plan**

**25 Oct 17**



**Dr. Ken Barker, SL  
AFLCMC/EZ  
DSN: 785-7213**



# LOA 2

## Goal & Objectives

---

- **Goal: Efficiently and effectively incorporate Systems Security Engineering (SSE) into the Systems Engineering (SE) process in all phases of the Acquisition Lifecycle to increase cyber resilience in AF systems**
- **Team Members: AFLCMC, AFTC, SMC, NWC, AFMC, AFRL, SMEs**
- **Objectives**
  1. **Process Integration:** Integrate SSE into SE processes and deliverables
  2. **Process Assessment:** Develop metrics to measure SSE incorporation into SE processes and deliverables
  3. **Product V & V:** Develop system cyber test and evaluation methodology and capability across the lifecycle for all AF systems - aircraft, weapons, C4ISR, IT, Space, Nuclear



## Integrate SSE into SE Processes

### ■ Status:

- Identified OPRs & formalized membership
- Implementing Action Plan
- Several process guides drafted/in coordination
- SE Tech Review entry/exit criteria drafted
- Cyber scorecard drafted; pilot apps under way
- Cyber Test & Evaluation Study Completed

### ■ Near-term Way Ahead:

- Update existing guides based on feedback and evolving policy/regulations
- Produce deliverables and work with Cyber Resiliency - Technical Advisory Council (CR-TAC) to disseminate/ institutionalize
- Continue interfacing across LOAs, especially with the LOA 3 Cyber Resiliency Support Team (CRST)

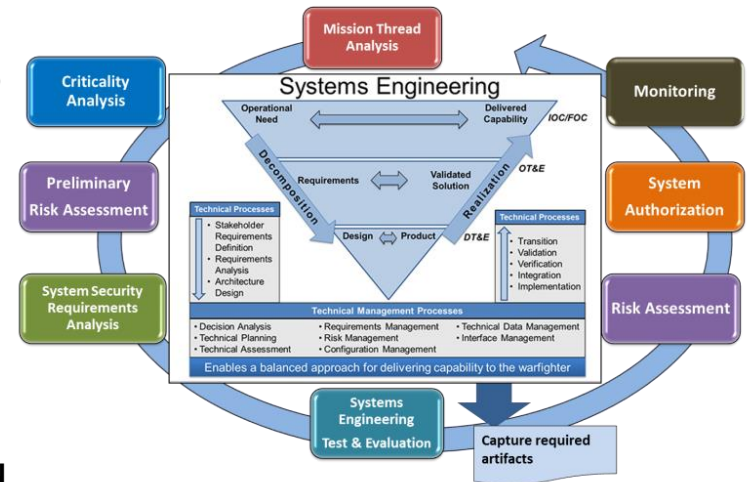



# LOA 2 Organization

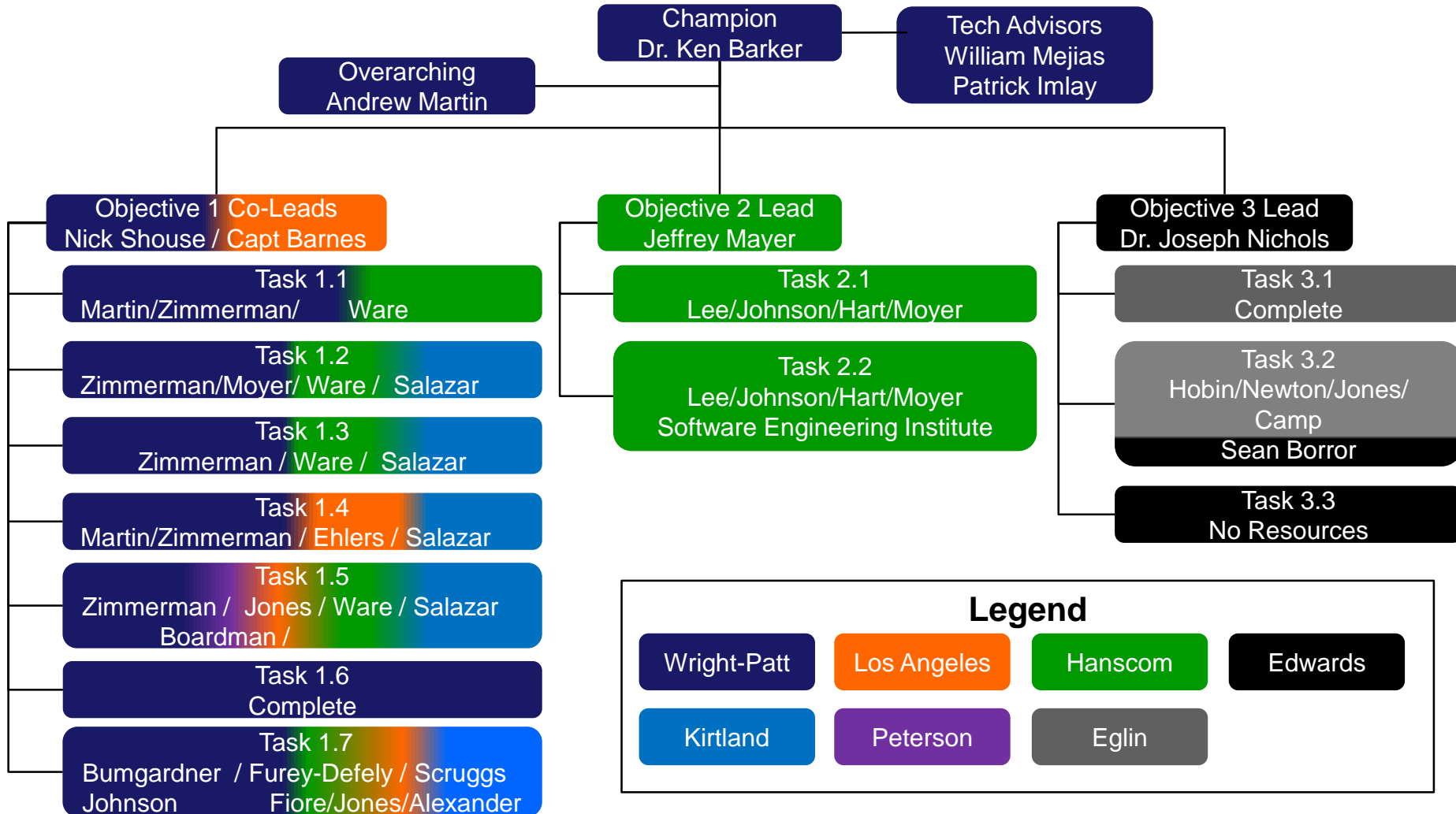

DISTRIBUTION A. Approved for public release: distribution unlimited.



# *Objective 1: Process Integration*

---

- **Objective Description:** Integrate SSE principles into SE processes and deliverables
- **OPRs:**
  - Leads: Mr. Nick Shouse, AFLCMC/EZS;  
Capt Cameron Barnes, SMC/ENX
  - Reps from AFLCMC, SMC, AFNWC, AFMC, FFRDCs, Contractor SMEs



# LOA 2 Input-Output

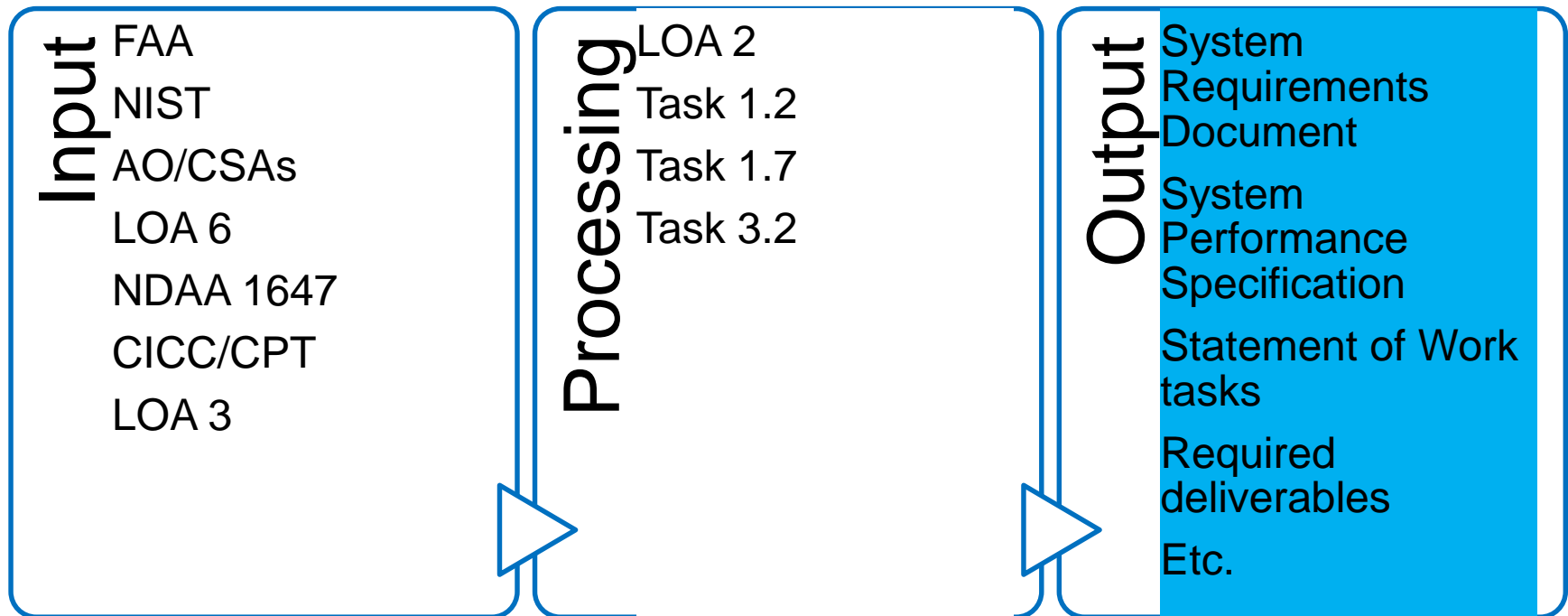



# LOA 2, Task 1.1

## Establish executable process for CPI & CC ID

### Task Description & Deliverables

#### Description

- Provide process guidance that enables programs to accurately identify and obtain independent review and validation of CPI/CC.

#### Deliverables

- CPI and CC Identification Process Guide

### Done Criteria

- Approval of CPI/CC Identification Process Guide by CR-TAC
- CPI/CC Identification Process Guide submitted for consideration to SAF/AQR for adoption as an Air Force Pamphlet (AFPAM) or referenced by AFPAM 63-113, Program Protection Planning for Life Cycle Management
- Guide posted to site accessible by all acquisition center program offices

DISTRIBUTION A. Approved for public release: distribution unlimited.

### Resource Loaded Schedule

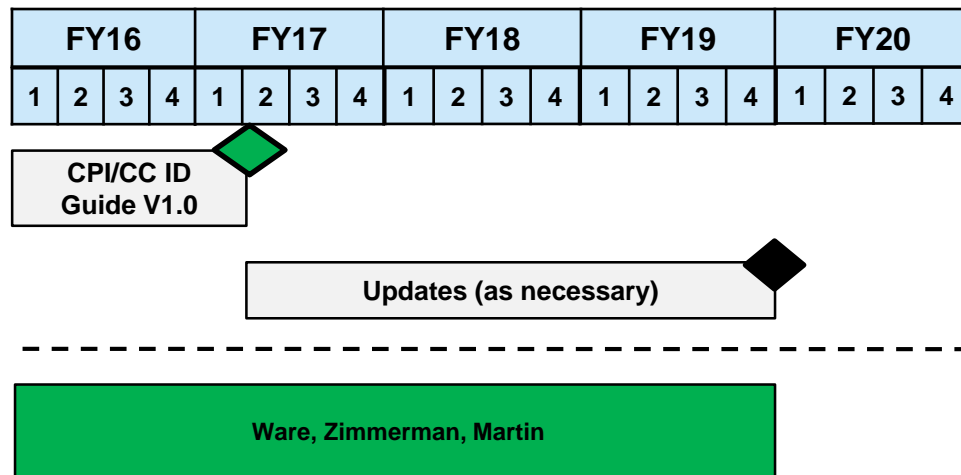

### Institutionalization

- Targeted Audience – Acquisition center program office, especially PMs, SEs, and SSEs
- Training – Analyze whether existing module of Program Protection course on CPI/CC ID is sufficient
- Accountability – Best practice to ensure correct implementation of DoDI 5200.39 and 5200.44
- Sustainment organization – Transition in FY19 or 20 to AFLCMC/EZSP and SMC/ENX for sustainment



# LOA 2, Task 1.2

## Define SSE & Integrate SSE into SE

### Task Description & Deliverables

#### Description

- To provide understanding of SSE terms and concepts within a *Guide for Accomplishing Comprehensive SSE*

#### Deliverables

- Guide for Accomplishing Comprehensive SSE, including Program Work Breakdown Structure (WBS), artifacts, and templates

### Done Criteria

- Approval of the Guide for Accomplishing Comprehensive SSE by CR-TAC
- Submitted to SAF/AQR for consideration as a replacement for the existing AFPAM 63-113 (*Program Protection Planning for Life Cycle Management*)
- Guide posted to site accessible by all acquisition center program offices

### Resource Loaded Schedule

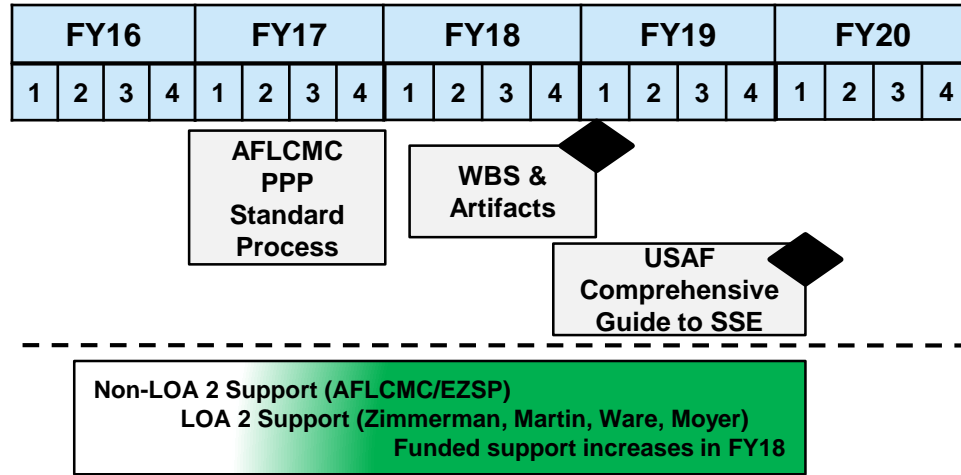

### Institutionalization

- Targeted Audience – Acquisition center program office, especially PMs, SEs, and SSEs
- Training – Potentially add module to Program Protection course
- Accountability – Recommended to PEOs as a best practice
- Sustainment organization – Transition in FY20 to AFLCMC/EZSP and SMC/ENX for sustainment

DISTRIBUTION A. Approved for public release: distribution unlimited.





# LOA 2, Task 1.3

## Establish executable process for System Security Risk Management

### Task Description & Deliverables

#### Description

- Provide one integrated system security risk management process that programs execute as part of their overarching risk management process, including the steps for risk planning, identifying, analyzing, handling, and monitoring.

#### Deliverables

- Risk Management Supplement to AFPAM 63-128, Integrated Life Cycle Management - Supplemental guide to integrate system security risk management

#### Done Criteria

- Approval of the Risk Management Supplement by the CR-TAC
- Submitted for consideration to SAF/AQR for update of the AFPAM 63-128, Integrated Life Cycle Management, to include system security risk management
- Supplement posted to site accessible by all acquisition center program offices

### Resource Loaded Schedule

FY16				FY17				FY18				FY19				FY20			
1	2	3	4	1	2	3	4	1	2	3	4	1	2	3	4	1	2	3	4

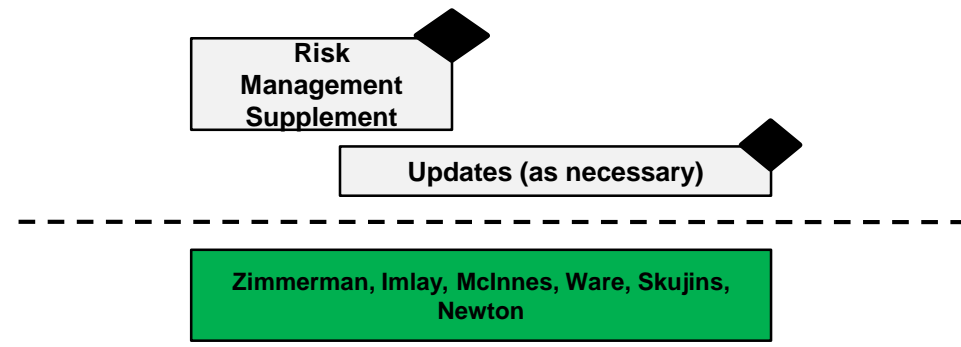

#### Institutionalization

- Targeted Audience – Acquisition center program office, especially PMs
- Training – TBD
- Accountability – Recommended to PEOs as a best practice
- Sustainment organization – Transition in FY19 or 20 to AFLCMC/EZAS and SMC/ENX for sustainment



# LOA 2, Task 1.4

## Develop and execute acquisition language guidance

### Task Description & Deliverables

#### Description

- Provide SSE-focused guidance to program offices for use in various acquisition docs
  - Offers programs a common starting point

#### Deliverables

- USAF SSE Acquisition Guidebook – Iterative development with periodic publication of updated versions

### Resource Loaded Schedule

FY16				FY17				FY18				FY19				FY20			
1	2	3	4	1	2	3	4	1	2	3	4	1	2	3	4	1	2	3	4



Ehlers, Ware, Martin, Zimmerman

### Done Criteria

- Interim deliveries/updates made as new information becomes available from other Cyber Campaign Plan activities
- Approval of the Final USAF SSE Acquisition Guidebook by CR-TAC
- Guide posted to site accessible by all acquisition center program offices

### Institutionalization

- Targeted Audience – Acquisition center program office, especially PMs, SEs, SSEs, and Contracts
- Training – TBD
- Accountability – Recommended to PEOs as a best practice
- Sustainment organization – Transition in FY20 to AFLCMC/EZSI and SMC/ENX for sustainment

DISTRIBUTION A. Approved for public release: distribution unlimited.



# LOA 2, Task 1.5

## Establish SETR SSE Entry & Exit Criteria

### Task Description & Deliverables

#### Description

- Establish SETR SSE entry/exit criteria that program offices across AFLCMC, SMC, and AFNWC can use to evaluate the design maturity of programs during various SETR activities.

#### Deliverables

- Updated SETR SSE Entry/Exit Criteria/Tasks outlined within the USAF SSE Acq Guidebook
- Updated SETR Toolset with SSE Entry/Exit Criteria

### Done Criteria

- Final SETR Entry/Exit Criteria reviewed/approved by the CR-TAC
- Update of AFLCMC SETR Toolset with approval by AFLCMC/EZSI

### Resource Loaded Schedule

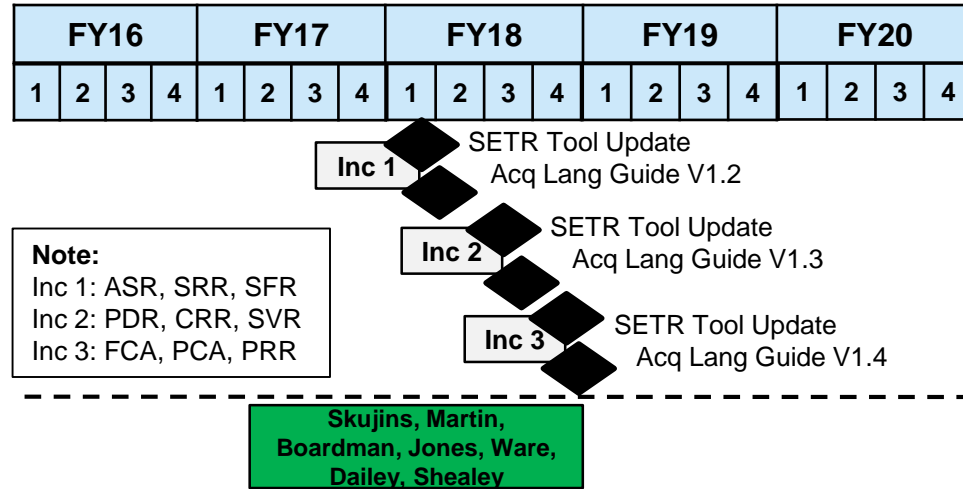

#### Note:

Inc 1: ASR, SRR, SFR  
 Inc 2: PDR, CRR, SVR  
 Inc 3: FCA, PCA, PRR

### Institutionalization

- Targeted Audience – Acquisition center program office, especially PMs, SEs, and SSEs
- Training – TBD
- Accountability – Recommended to PEOs as a best practice
- Sustainment organization – Transition of SSE Acq Guidebook in FY20 to AFLCMC/EZSI and SMC/ENX for sustainment. SETR Toolset will be continue to be maintained by AFLCMC/EZSI.



# LOA 2, Task 1.6 (COMPLETE)

*Provide recommended system security language for ICDs, CDDs, and CPDs*

## Task Description & Deliverables

### Description

- Create guidance that enables program offices to interact with users and inform the development of weapon system requirements that account for SSE activities throughout the acquisition life cycle.

### Deliverables

- Updated SSE Acquisition Guidebook identifying process owners; summaries of applicable requirements development processes; and sample ICD, CDD, and CPD requirements language

### Done Criteria

- Approval of USAF SSE Acquisition Guidebook v1.1 by the CR-TAC

## Resource Loaded Schedule

FY16				FY17				FY18				FY19				FY20			
1	2	3	4	1	2	3	4	1	2	3	4	1	2	3	4	1	2	3	4

SSE Acq  
Lang V1.1



**Any updates part of Task 1.4**

Imlay, Martin,  
Zimmerman, Moyer

### Institutionalization

- Targeted Audience – Acquisition center program office, especially PMs, SEs, and SSEs
- Training – See Task 1.4
- Accountability – See Task 1.4
- Sustainment organization – See Task 1.4



# LOA 2, Task 1.7

## Develop system and acquisition security requirements for programs

### Task Description & Deliverables

#### Description

- Develop a requirements construct modeled after the format used in (MIL-HDBK) 516C, that focuses on criterion, standards, methods of compliance (i.e., verification), and references.

#### Deliverables

- Traceable to NIST controls for reciprocity and audit purposes.
- Aligned with various domain frameworks
- An USAF-wide solution that includes areas of domain-agnostic requirements

### Done Criteria

- Approval of the Final SSE Requirements Construct by CR-TAC
- Construct posted to site accessible by all acquisition center program offices

### Resource Loaded Schedule

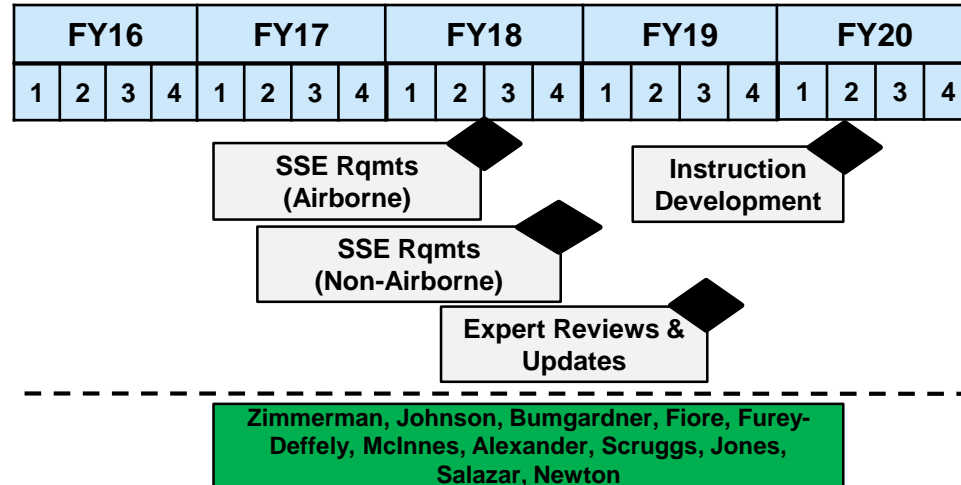

### Institutionalization

- Targeted Audience – Acquisition center program office, especially PMs, SEs, and SSEs
- Training – Guidance/instruction on use of Construct
- Accountability – Potentially update Air Force Instruction 17-101 or other instruction
- Sustainment organization – Transition in FY20 to AFLCMC/EZSI and SMC/ENX for sustainment



# *Objective 2: Process Assessment*

---

- **Objective Description:** Develop metrics to measure SSE incorporation into SE processes and deliverables
- **OPR:**
  - Lead: Mr. Jeff Mayer, AFLCMC/EZC
  - Representatives from AFLCMC, SMC, NWC, DOEs



# LOA 2, Task 2.1

## Develop a Cyber Health Scorecard to measure SSE process health within program offices

### Task Description & Deliverables

#### Description

- Develop scorecard for program office use
  - Enable programs to evaluate quality of applied programmatic practices

#### Deliverables

- Final Enhanced Guidance
- Updated Overview and Training briefings
- Health Scorecard Configuration Management Plan
- Cyber Health Scorecard

### Done Criteria

- Final Cyber/SSE Health Assessment reviewed/approved by the CR-TAC
- Guidance recommending use of tool sent by CROWS or SAF/AQR to PEOs
- PEO Enterprise Roll-up Capability integrated into tool
- Assessment posted to site accessible by all acquisition center program offices

### Resource Loaded Schedule

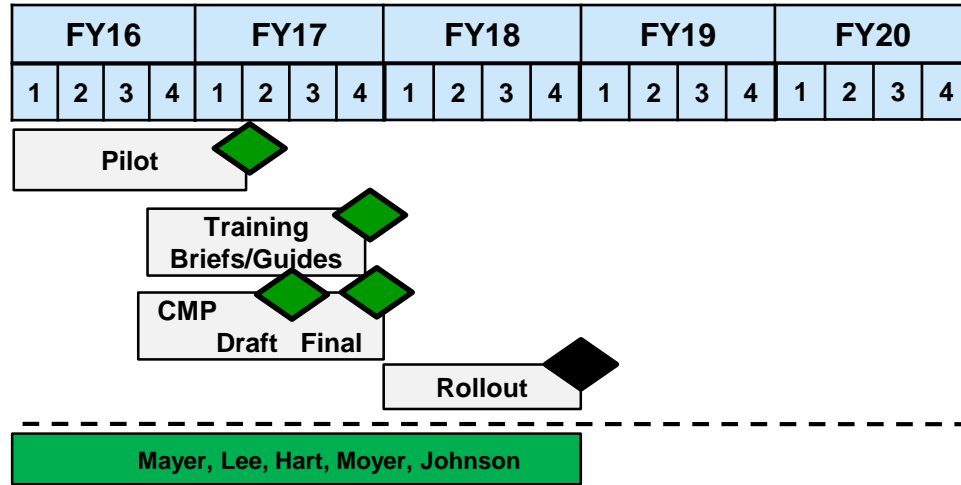

### Institutionalization

- Targeted Audience – Acquisition center program office, including PMs, System Program Directors, & PEOs
- Training – Narrated training briefs and enhanced guidance
- Accountability – Memorandum from SAF/AQR to PEOs encouraging use of assessment
- Sustainment organization – Potential transition in FY19 to AF SE Assessment Model (SEAM) and managed by AFMC/ENS and SMC/ENE

DISTRIBUTION A. Approved for public release: distribution unlimited.



# Develop methodologies & metrics to measure our systems' security and resiliency

## LOA 2, Task 2.2

### Task Description & Deliverables

#### Description

- Form an AF-level Cybersecurity Metrics Framework
  - Allows capturing and summing metrics to provide system and/or platform level insight
  - Conduct pathfinders, refine metrics, and instantiate a collection tool & analysis method

#### Deliverables

- AF Cyber Metrics Framework

### Done Criteria

- Final AF Cyber Metrics Framework reviewed/ approved by the CR-TAC
- Framework posted to site accessible by all acquisition center program offices

### Resource Loaded Schedule

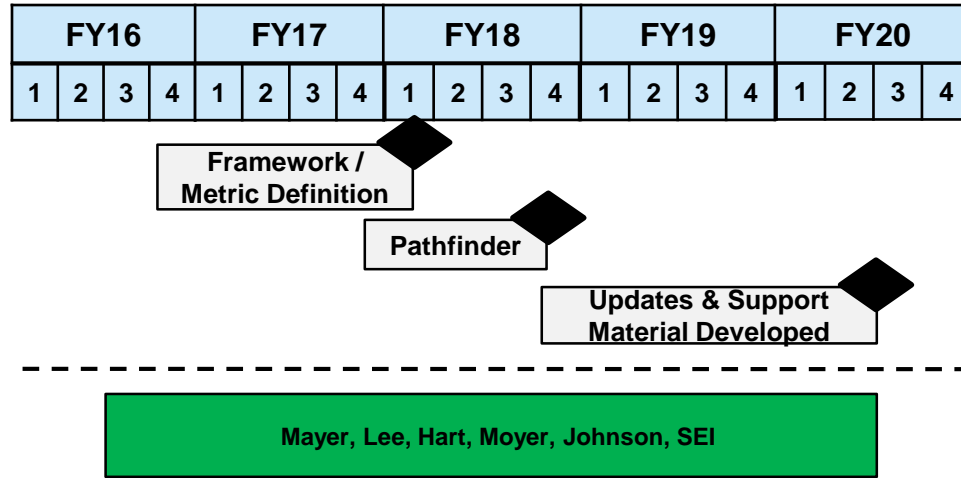

### Institutionalization

- Targeted Audience – Acquisition center program office, including PMs, System Program Directors, & PEOs
- Training – TBD
- Accountability – TBD
- Sustainment organization – TBD





# *Objective 3: Product V&V*

---

- **Objective Description:** Develop system cyber test and evaluation methodology and capability across the lifecycle for all AF systems - aircraft, weapons, C4ISR, IT, space, nuclear
- **OPR:**
  - Dr. Joe Nichols, AFTC/CZ
  - Reps from AF/TE, AFOTEC, AFMC, AFLCMC, SMC, NWC, AFRL, NASIC, DOEs



# LOA 2, Task 3.1 (COMPLETE)

## Monitor & provide Cyber T&E Study

### Task Description & Deliverables

#### Description

- Complete Cybersecurity Test and Evaluation (CTE) Study under guidance of 46<sup>th</sup> Test Squadron
  - Identify environment, infrastructure, tools, methodology, manpower, & resources required

#### Deliverables

- Cyber T&E Study
  - Capability and infrastructure gaps
  - Process recommendations & investment map
  - Manpower study on required expertise and workforce requirement

### Resource Loaded Schedule

FY16				FY17				FY18				FY19				FY20			
1	2	3	4	1	2	3	4	1	2	3	4	1	2	3	4	1	2	3	4

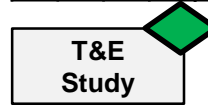

-----

**Greene**

### Done Criteria

- Completion of the Cyber T&E Study to inform investment planning and task 3.2

### Institutionalization

- The Cyber T&E Study is complete and maintained by the 46 TS. Analysis will be used to inform investment planning and task 3.2



# LOA 2, Task 3.2

## Cyber Test Technique Development

### Task Description & Deliverables

#### Description

- Develop cybersecurity test strategies, document best practices and lessons learned, and produce a cybersecurity test techniques handbook

#### Deliverables

- Cyber System Risk Assessment Guidebook
- Cyber T&E Guidebook

### Done Criteria

- All guidebooks and methodology approved for use by Headquarters AF/T&E
  - 46 TS coordination and comment resolution completed
  - Internal LOA 2 coordination and comment resolution completed
  - Cross-LOA coordination and comment resolution completed

### Resource Loaded Schedule

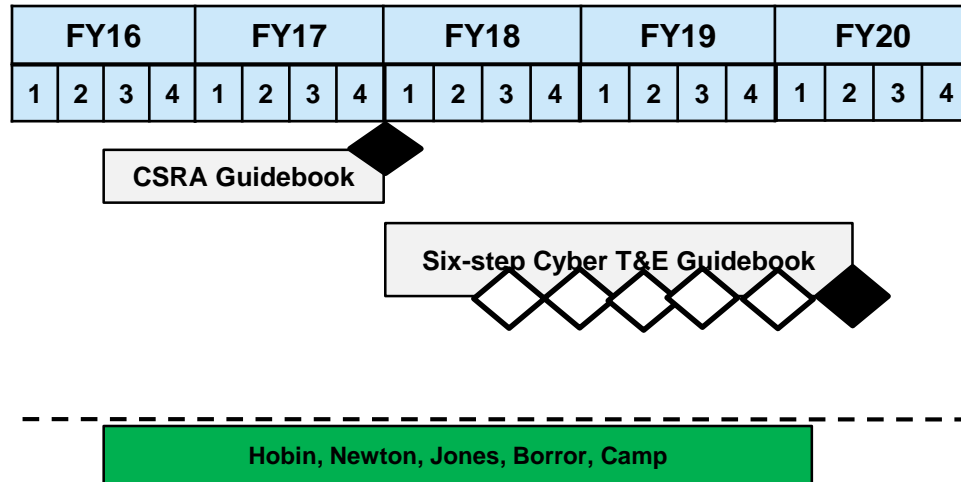

### Institutionalization

- Targeted Audience – Acquisition center program office and Air Force Test Center, especially 46 TS
- Training – TBD
- Accountability – TBD
- Sustainment organization – Transition upon completion to the 46 TS for sustainment

DISTRIBUTION A. Approved for public release: distribution unlimited.



# Schedule

