



*A Low Voltage
Command-Arm System
for Distributed Fuzing*



DISTRIBUTION STATEMENT A. Approved for Public Release. Distribution is Unlimited

TECHNOLOGY DRIVEN. WARFIGHTER FOCUSED.

**NDIA Fuze Conference
May 15-17, 2018
San Diego, CA**

Presented by:
Mark Etheridge
**U.S. Army Aviation and Missile Research,
Development, and Engineering Center**

- This project is sponsored by the **Joint Fuze Technology Panel (JFTP)**
 - FATG II (Tailorable Effects)
- **Alan Durkey, Naval Air Warfare Center**
- **Adedayo Oyelowo, Naval Surface Warfare Center**

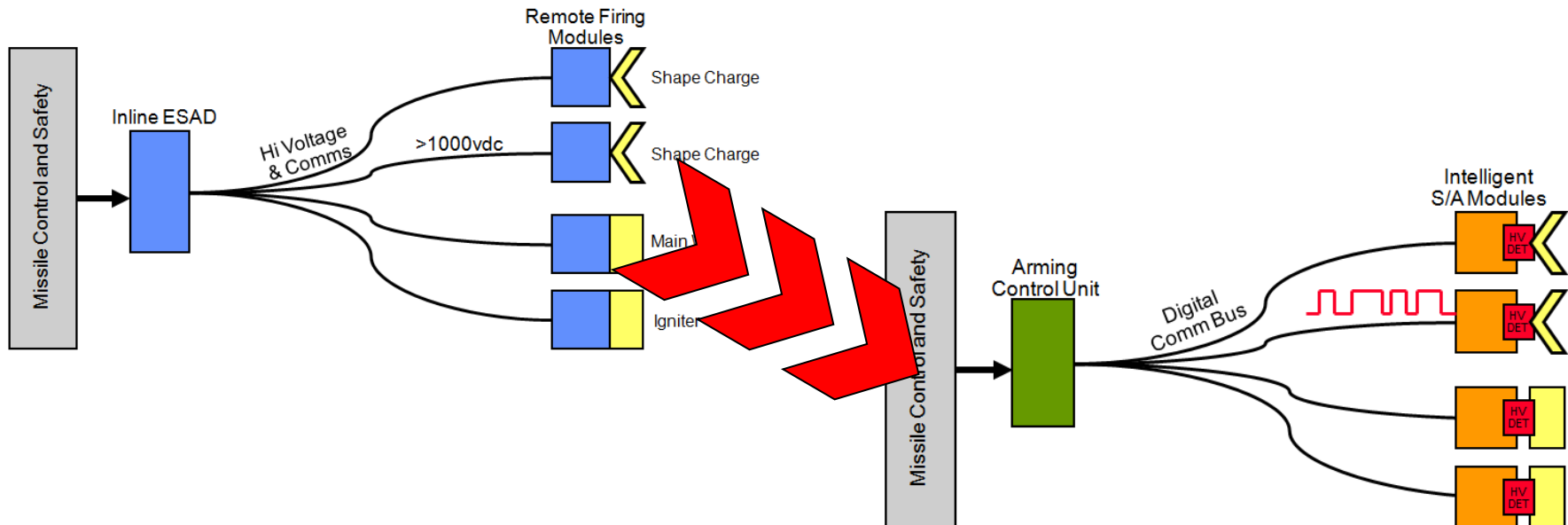

Project History



- This project began in 2010 with a 6.2 effort to develop some generic architectures so as to define some minimal hardware & signal guidelines.
 - Participants: Army-AMRDEC, NAWC, Sandia
 - Architectures: Multiple-Try, Frequency Shift, eUQS
 - Successful in gaining acceptance.
 - FESWG 'approval' in February, 2014
 - FESWG ad-hoc stood up; JOTP document was started.

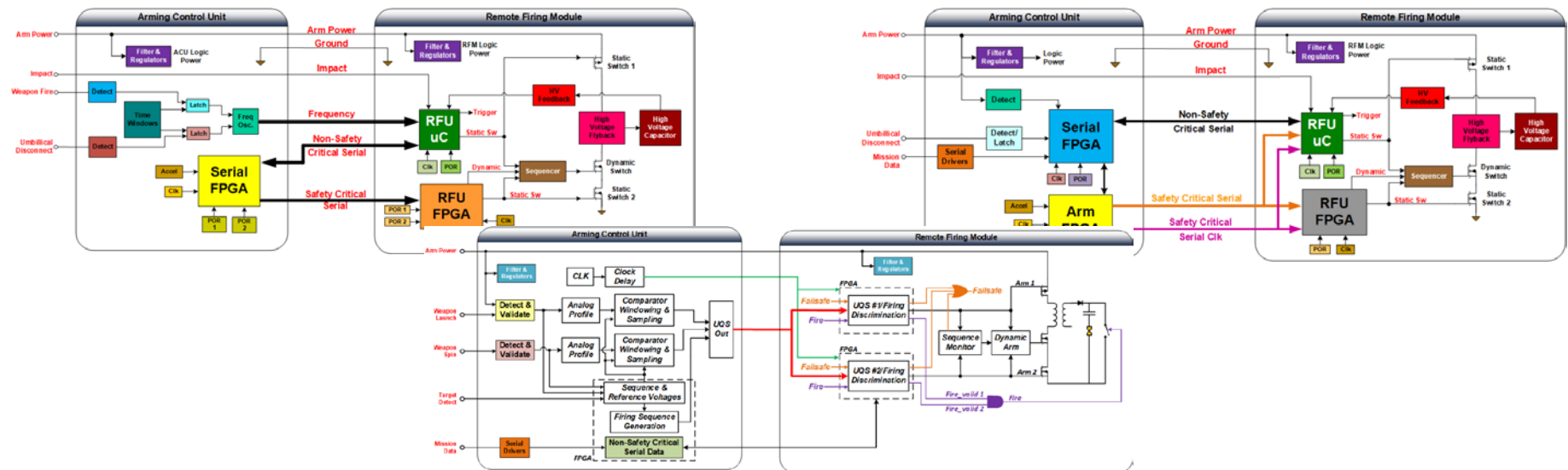

Project History



- A 6.3 program then began in 2015 to pursue form, fit, and function designs with the goal of further defining the ‘solution space’
 - Participants: Army-AMRDEC, NAWC, NSWC-IH.
 - Frequency Shift architecture was chosen for implementation
 - Program ending in FY18/19.
 - Goals met!!
 - Guidelines were refined and new architectures added.
 - JOTP document completed and under final review.

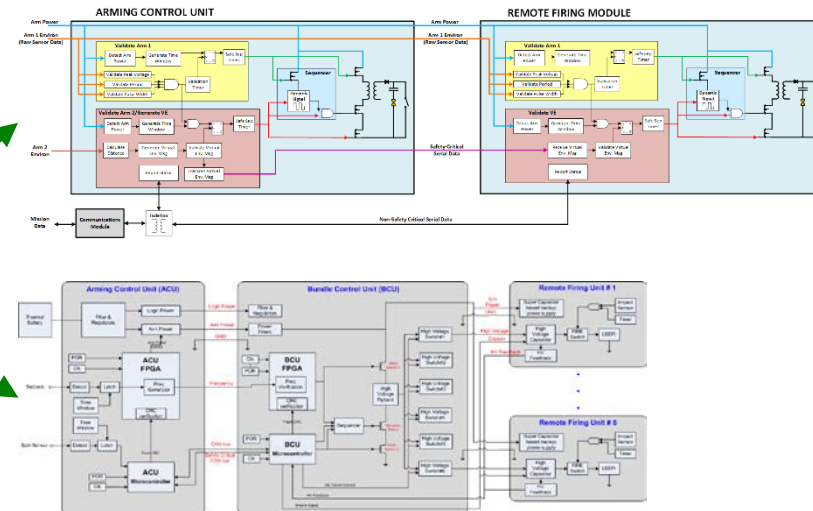
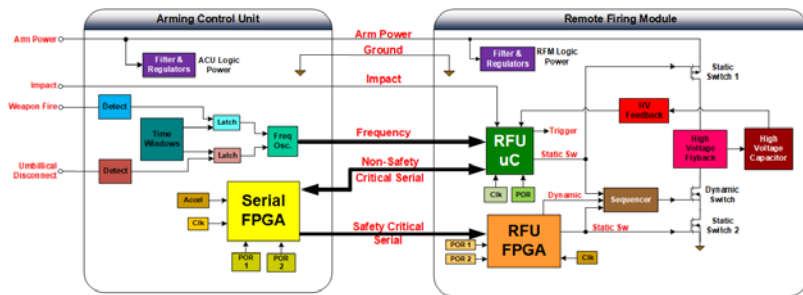

TECHNOLOGY DRIVEN. WARFIGHTER FOCUSED.
UNCLASSIFIED

Guidelines for the design of Low Voltage Command- Arm Distributed Fuzing Systems

PLEASE NOTE!!

1. The following slides are guidelines...not requirements. *Consult with the appropriate Service Safety Authority for acceptability if this guidance cannot be adhered to.*
2. Some of the guidelines are not presented.
3. The document is in final review so there may be some changes from what is presented here.

Definitions



Distributed Fuze System

- A configuration and/or architecture such that one or more fuze safety critical functions are allocated throughout the munition and/or system such that the environment sensing may occur at some distance and in a physically different module from the explosive or pyrotechnic element.

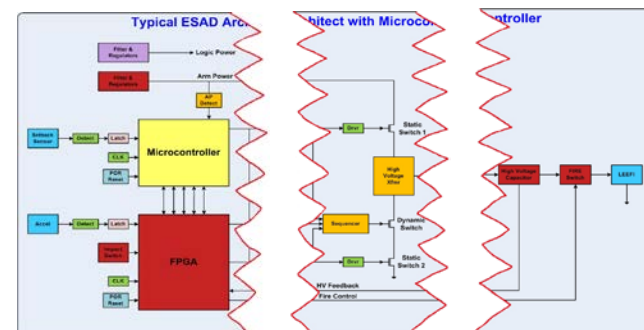
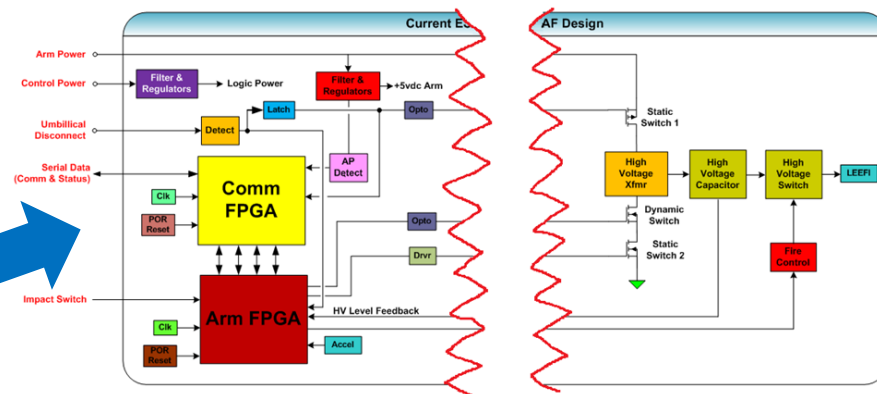
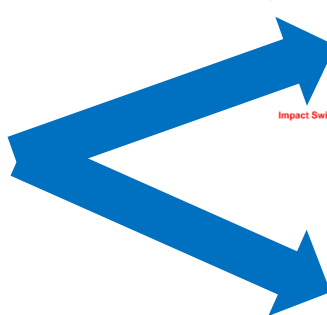
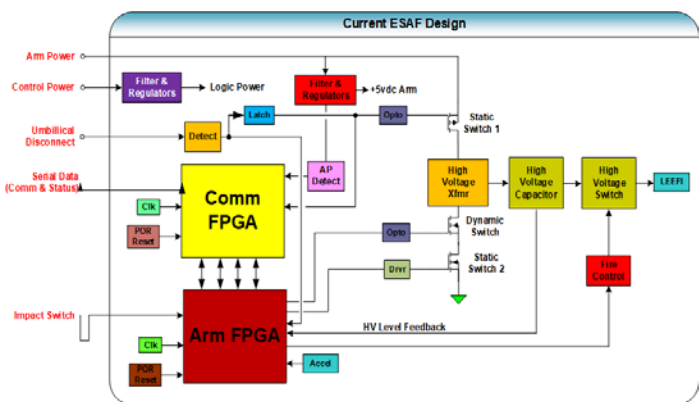

- **Arming Signal:** the electrical representation of a unique arming environment that is transmitted, processed, and validated for safety feature activation.
 - Encompasses both raw sensor data and a virtual environment
- **Virtual Environment (VE):** a unique robust electrical signal that is derived or translated from a physical arming environment sensor output. It is a subset of arming signals.
 - Encompasses both analog and digital signals
 - VEs are a signal that is designed/engineered to be unique and robust .
- **Both definitions do not limit what an arming signal or VE can be.**

Arming Control Unit (i.e. the Master S&A)

- The Arming Control Unit (ACU) directly senses, processes, and validates the physical arming environments. The ACU should translate the physical arming environments into Virtual Environments (VE), if necessary, and transmit all arming signals to the Remote Firing Modules (RFMs).

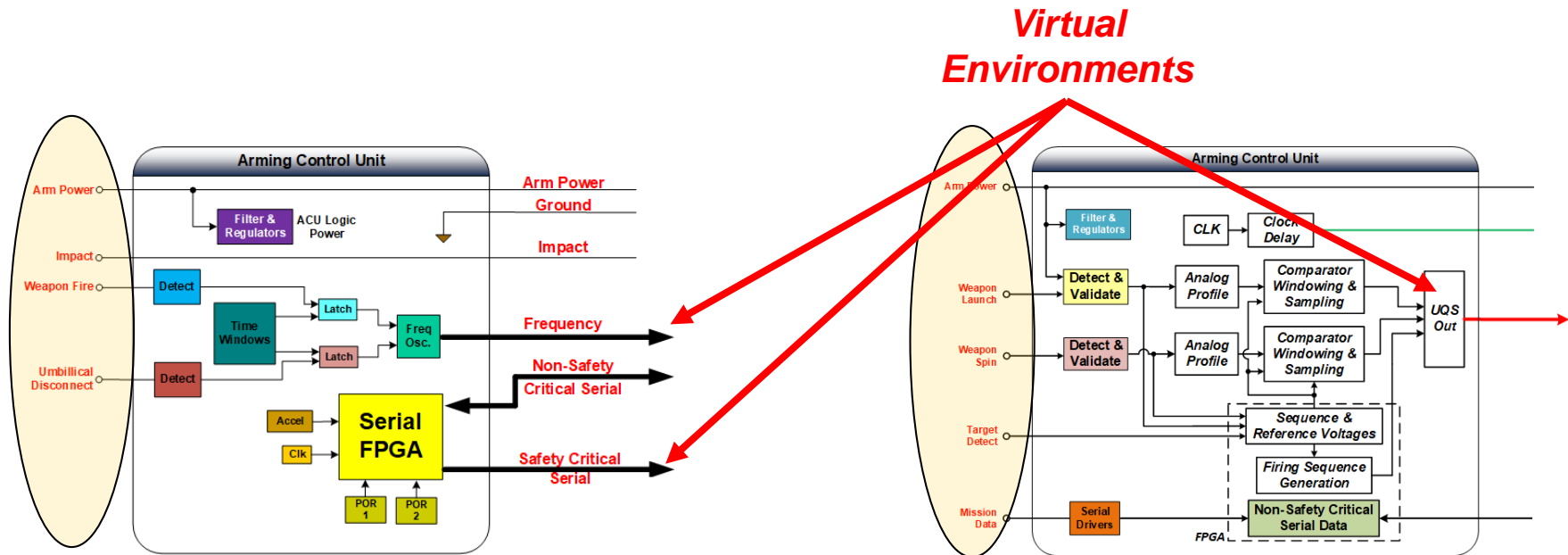

Guidelines



- Based on system requirements, the ACU may maintain an active link with all RFMs that are in use after the fuze system is properly armed.

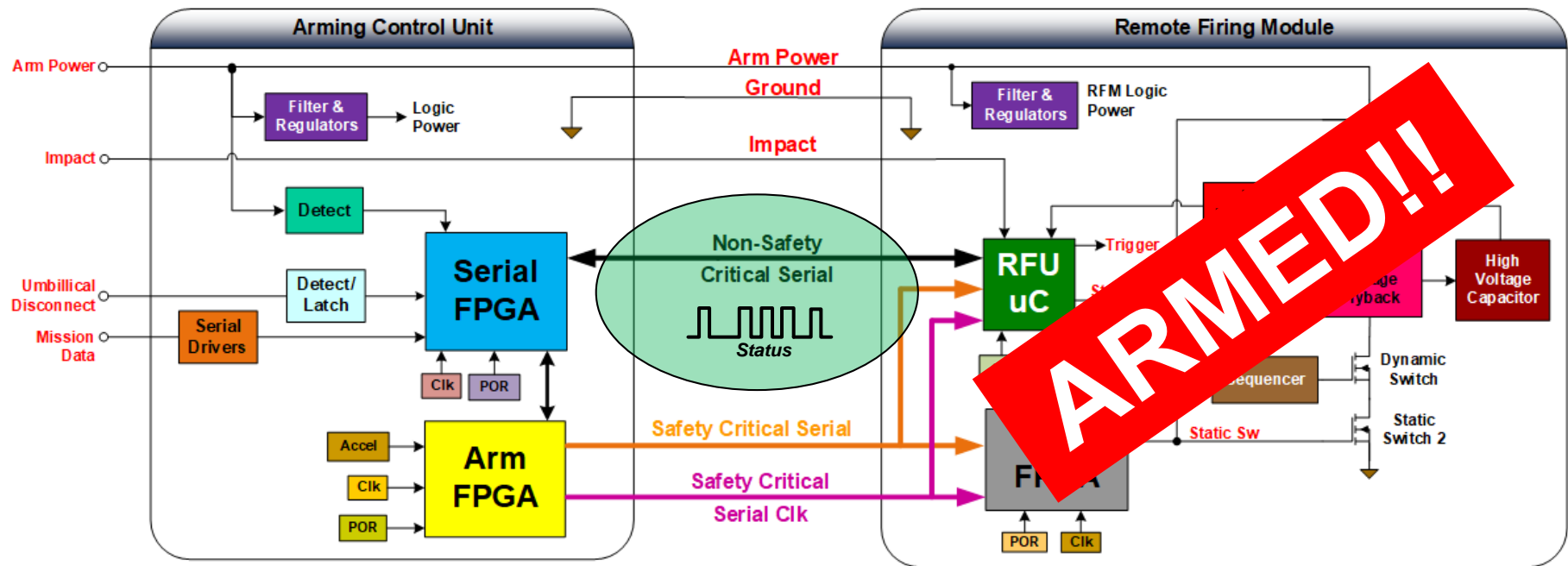

Guidelines



Remote Firing Module

- The RFM should contain all required arming switches.

Compliant

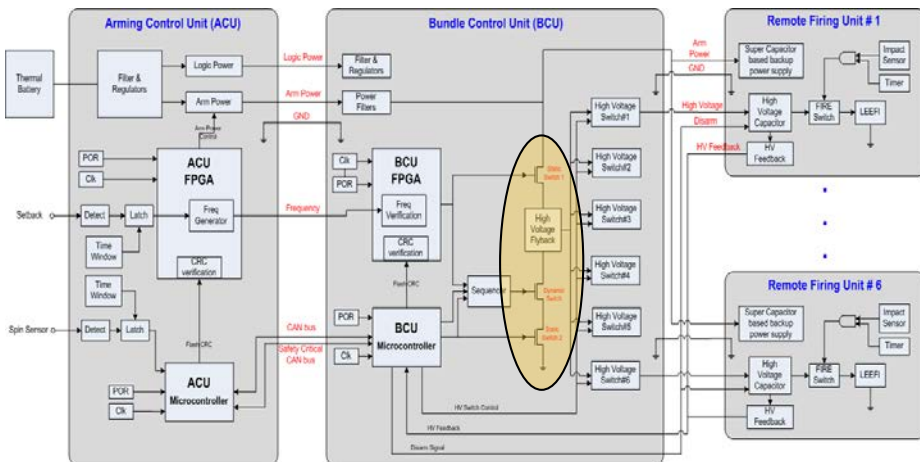
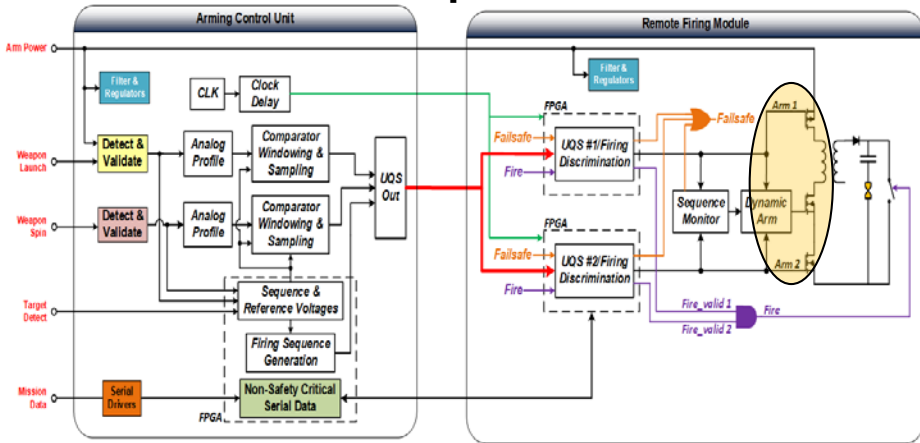

Consult!!!

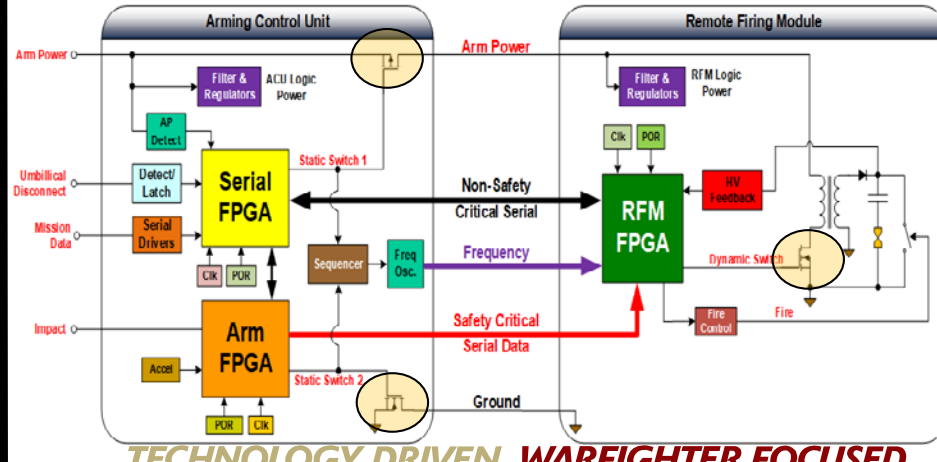
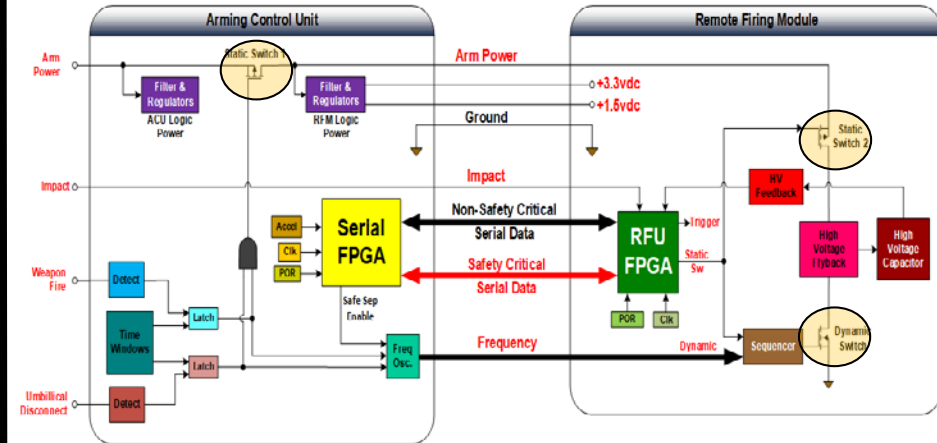

TECHNOLOGY DRIVEN. WARFIGHTER FOCUSED.
UNCLASSIFIED

- **Power to the safety critical features in the RFM should be applied as late in the launch sequence or operational deployment as practical.**
- **It is preferred that the dynamic signal for driving the high voltage transformer be generated within the RFM.**
- **Timing/Sequencing of the VE signals should be validated within the RFM.**
- **All Arm Delay Timers should reside within the RFM.**

Arming Signals

- There should be a minimum of two unique arming signals transmitted to the RFM for proper arming of the fuze system. A robust physical environmental signal (i.e. raw sensor data) may be used in lieu of a VE arming signal.
 - “Hybrid” Architecture...1 Physical & 1 Virtual Arming Signal

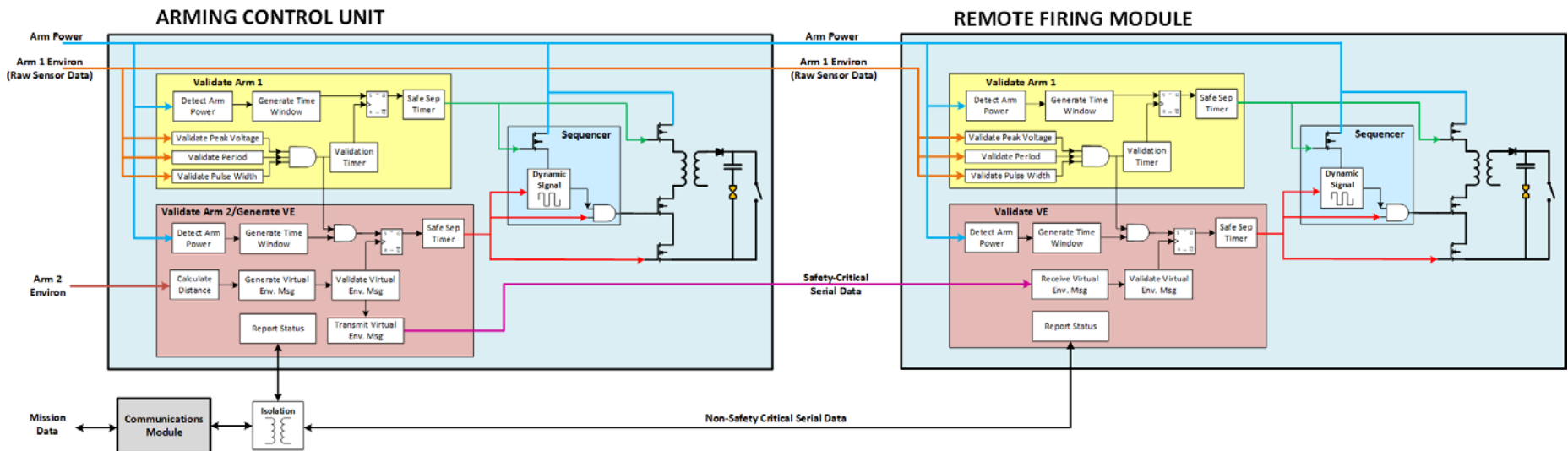

Guidelines



- The generation of the VE signals should be implemented with independent and dissimilar logic that is physically and functionally partitioned. The degree of dissimilarity should be sufficient to ensure that any credible common cause susceptibility will not result in an inadvertent arming signal transmission in other logic devices. Where practical at least one VE signal should be implemented with discrete components.
- This guidance also applies to the processing of the received arming signal at the RFM and subsequent activation of any safety features contained within.

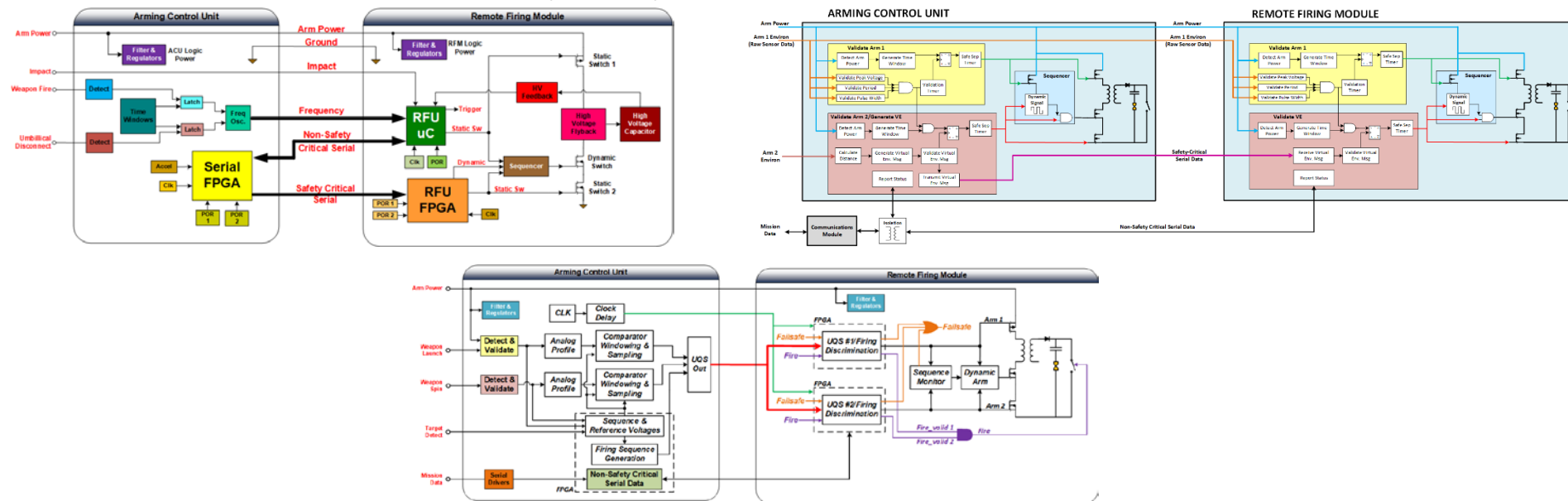

Guidelines



Virtual Environment Messaging

- Each safety-critical message should be implemented as a dedicated, one-way communication. All non-safety critical messages (polling, mission data, message ack.) may be transmitted/received on a separate communication line.

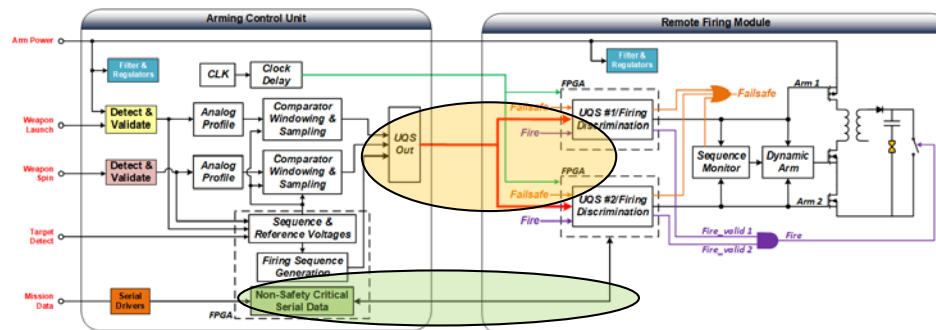
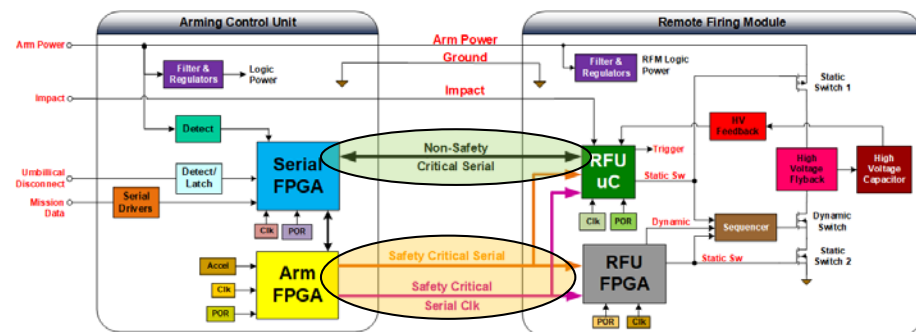
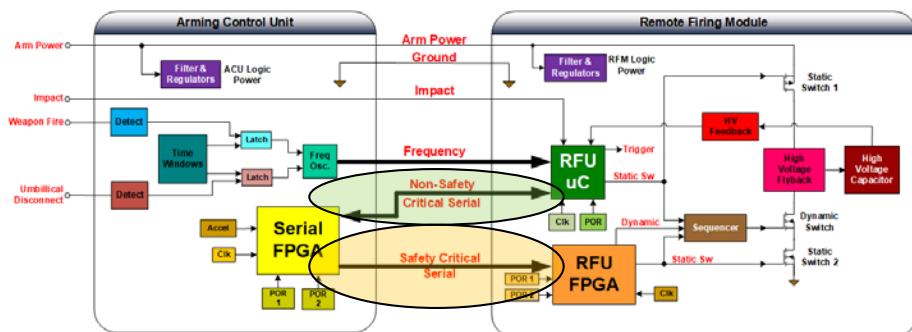

Guidelines



- The preferred method is to dynamically generate the VE message based on events that occur throughout an arming environment.
- Where generation of the VE message is not practical, pre-stored VE serial messages may be utilized. The message must be further distinguished by a minimum of two additional validation methods or features in order to mitigate subversion of safety features.
 - Time Windowing, Sequencing, Serial Clock Frequency, etc.

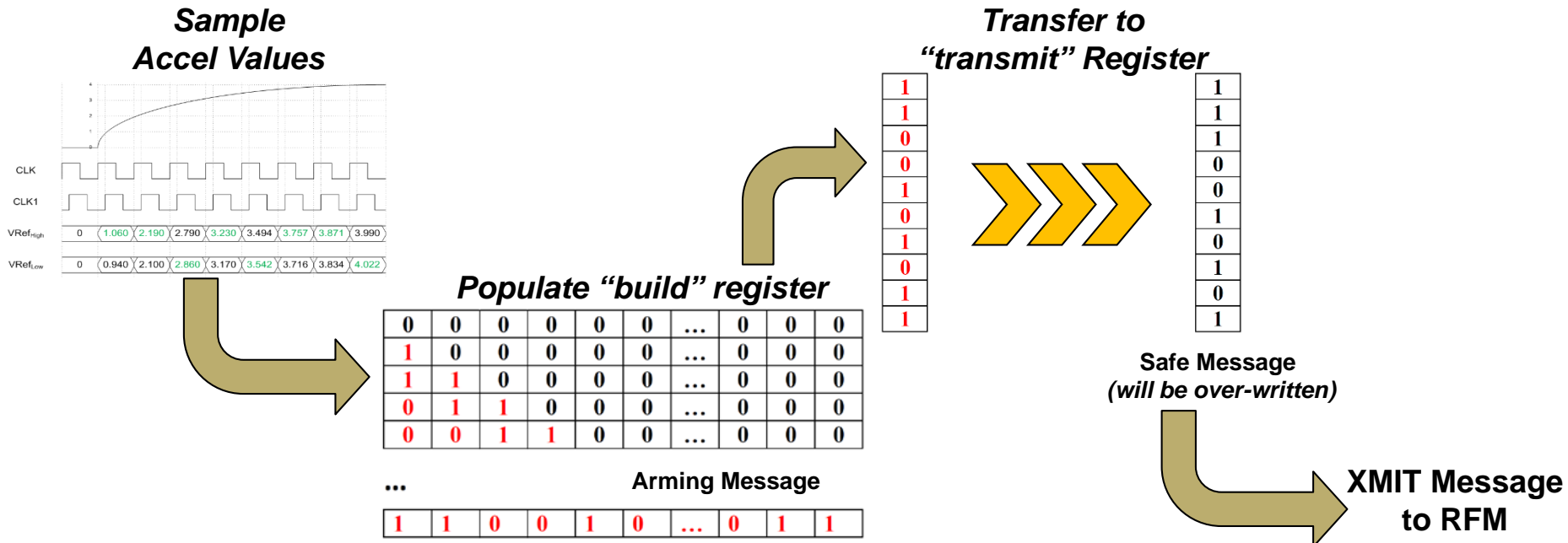

Guidelines



- Each VE message should be unique and unambiguous, from any and all other VE messages using strong data typing.
- Tolerance to corrupt/invalid data should be characterized through analyses and test. Analysis and test methodologies will be provided to the appropriate Service Safety Authority for approval.

Recommended Data Failure Modes

Failure Mode	Definition
Repetition	The same message is sent all the time (Ex. Babbling idiot)
Deletion	All or part of the messages or message content is missing
Insertion	A message is received unintentionally and is perceived as the correct address (Ex. Data from the wrong source)
Incorrect Sequence	Messages are not received in the correct order
Corruption	One or more data bits are changed in the message
Early Arrival	The message is received correctly before it is expected
Late Arrival	The message is received correctly later than expected
Masquerade	A non-safety-related message could be interpreted as a safety-related message
Inconsistency	Two or more receivers have a different view of the transmitted data or the receivers may be in different states



• Frequency Shift Architecture

- An initial frequency is sent to the RFM at the beginning of the arming environment and is “shifted” to another frequency at completion of the arming environment. The RFM must detect this change in frequency within a specific time window for it to be valid.
- **Arming Signals:** Analog Square Wave, 32-bit *generated* serial message

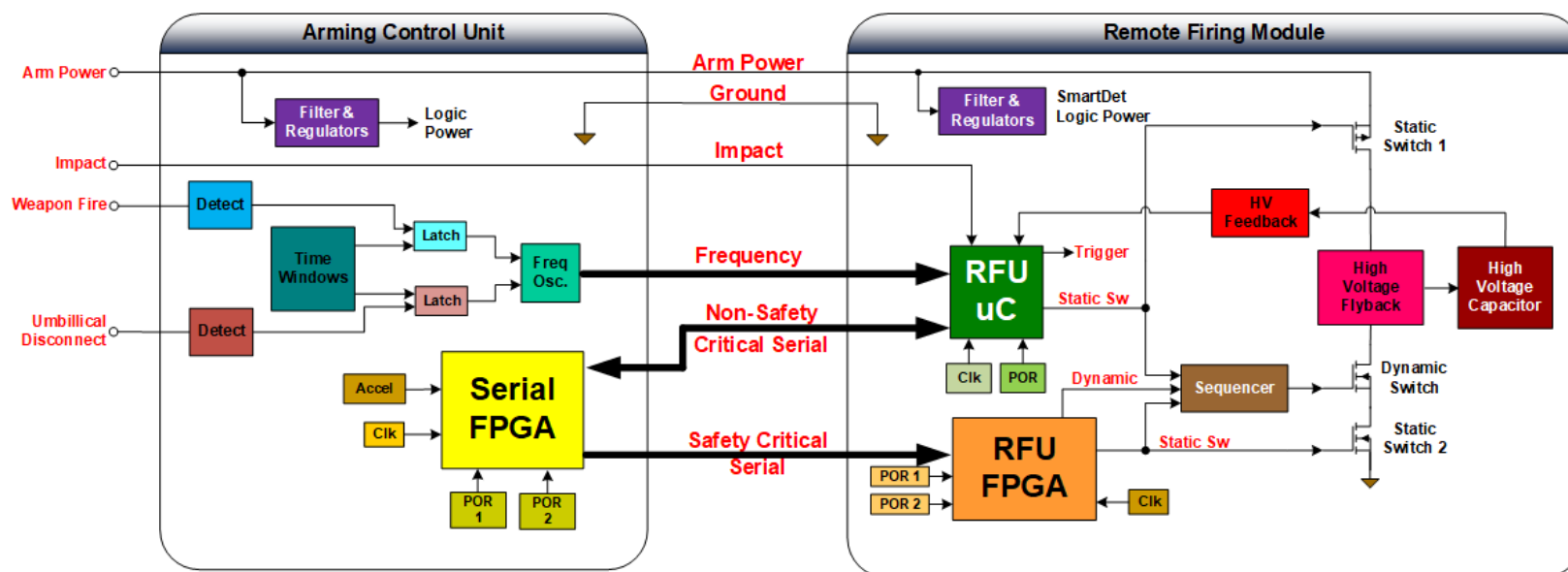



• Hybrid Architecture

- This architecture utilizes a robust signal from a physical arming environment and a serial message as a VE. Note that the safety features are located in both the ACU and RFM.
- **Arming Signals:** Raw Sensor Data, 32-bit *generated* serial message

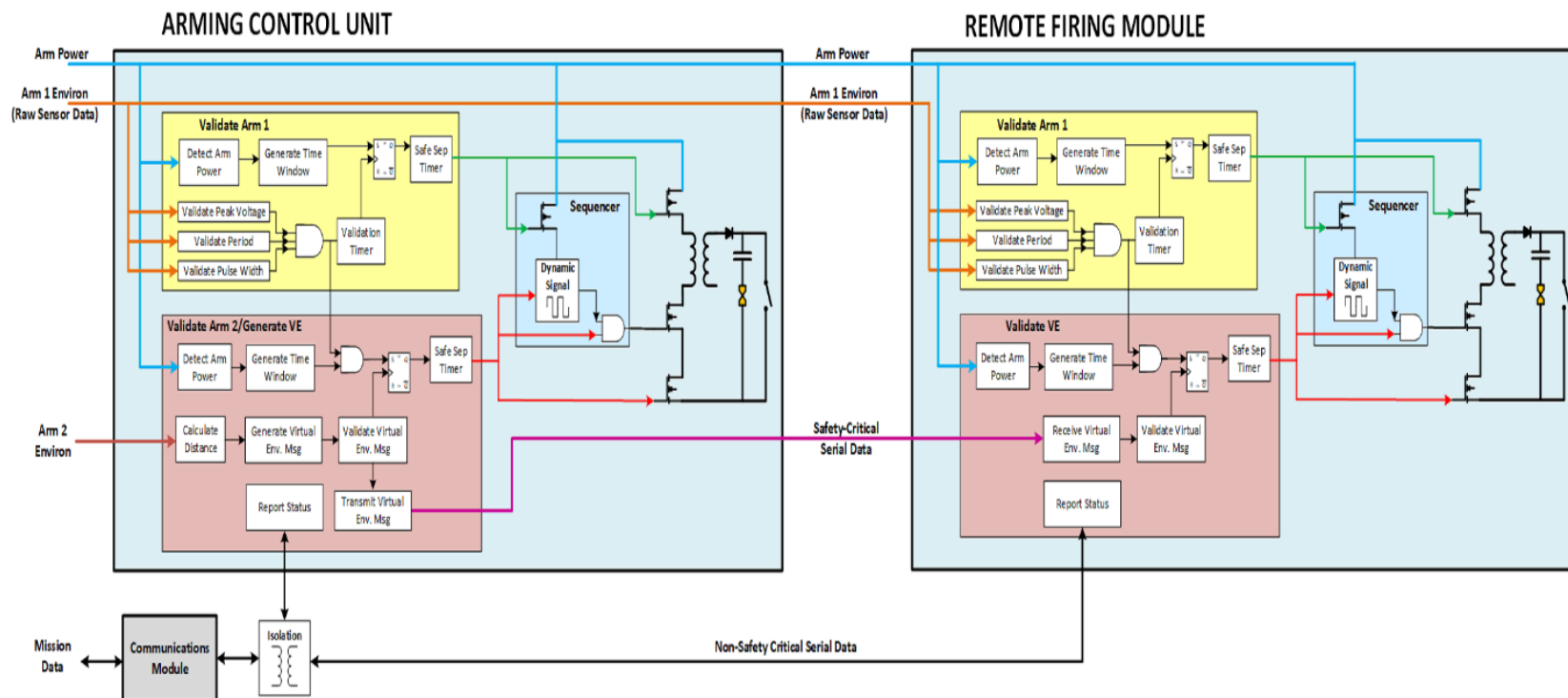



• Bundle Control Unit

- This architecture utilizes a centralized safety module and distributes the firing voltage to the remote locations. The VEs are communicated between the ACU and Bundle Control Unit (BCU).
- **Arming Signals:** Analog Square Wave (Frequency Shift), 7-byte *generated* Controller Area Network (CAN) *broadcast* message

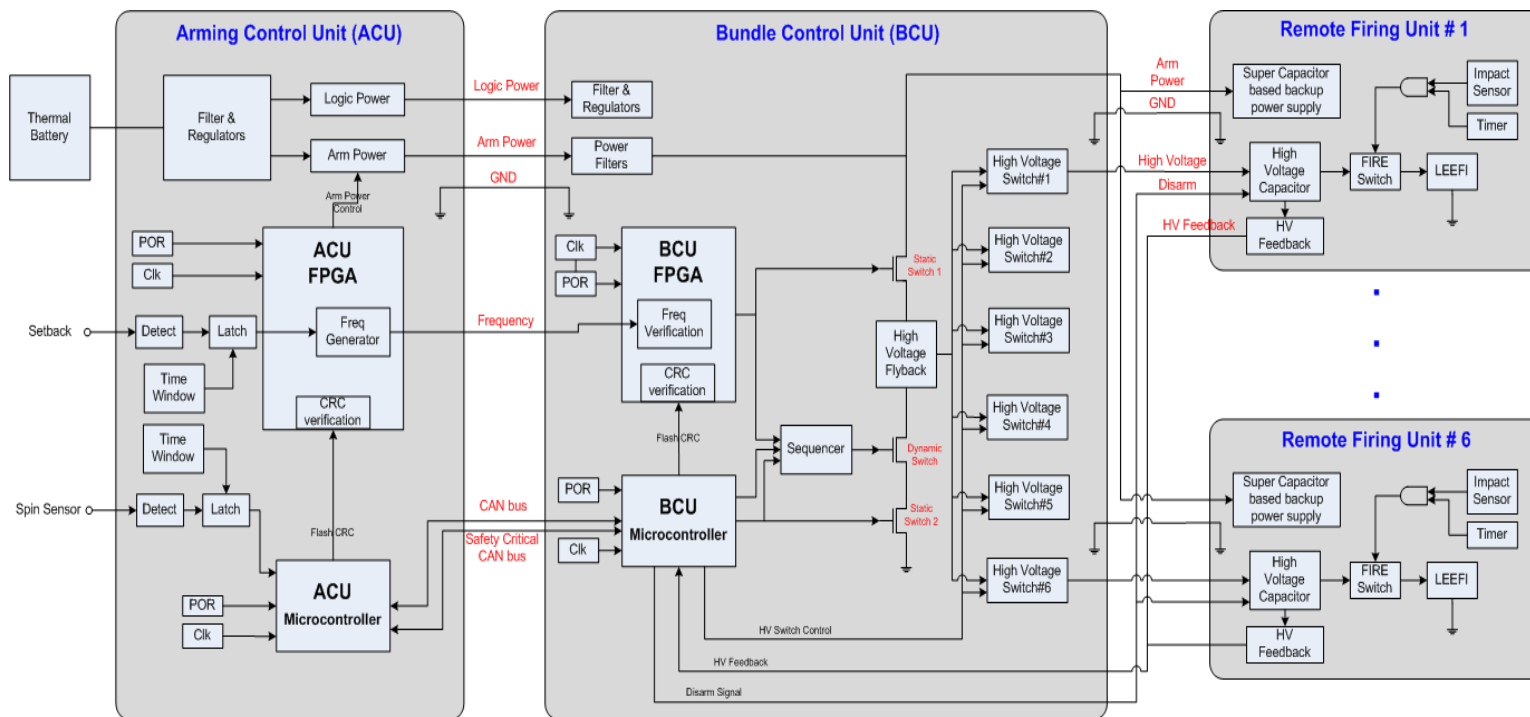

U.S. ARMY
RDECOM

Current Solution Space



• Multiple-Try Architecture

– Multiple attempts at arming.

- When given the correct arming sequence, the RFM will arm with four serial commands.
- Should any errors occur, the RFM will be locked in a “safe” state and reset for a minimum amount of time defined as the “reset time.”
- Once the RFM exits reset, the arming process can be attempted again. The ACU must now send a valid reset command *in addition to* and before the previous commands.

– **Arming Signals:** 24-bit stored serial messages

Command #	Command Name	Purpose
1	Key	“Unlocks” the remote fireset. Fireset must receive key word before it will accept other commands.
2	Static Switch 1	Enables Static Switch 1 on the remote fireset.
3	Static Switch 2	Enables the Static Switch 2 on the remote fireset.
4	Arm	Enables Dynamic Signal generation.
5	Reset	Unlocks the remote fireset from a safe state if an error has occurred.

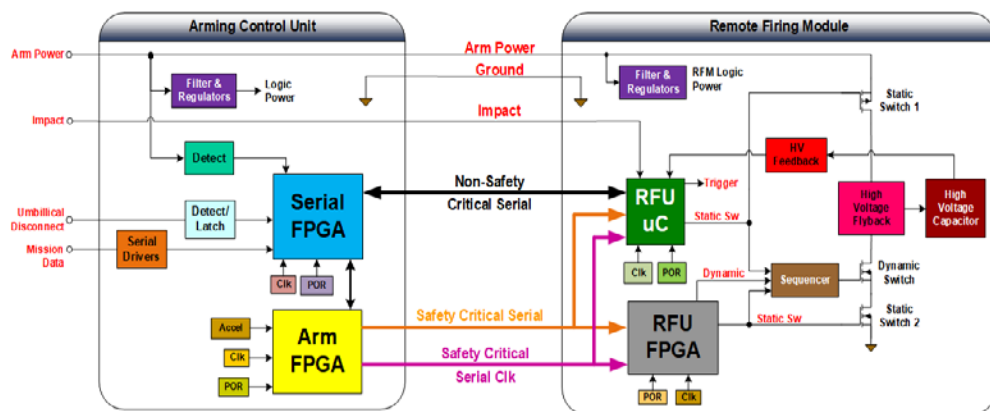

U.S. ARMY
RDECOM

Current Solution Space



• Electronic Unique Signal (eUQS) Architecture

- A sequence of independent events in a specified pattern that is extremely unlikely to happen in normal and abnormal environments
 - 24 events for Single-Try; “Many more” (application specific) for Multiple-Try
- Each event is communicated and evaluated one at a time
- **Arming Signals:** Two 24-bit *generated* data streams (one per arming environment)
 - Data streams are **not** serial communications.

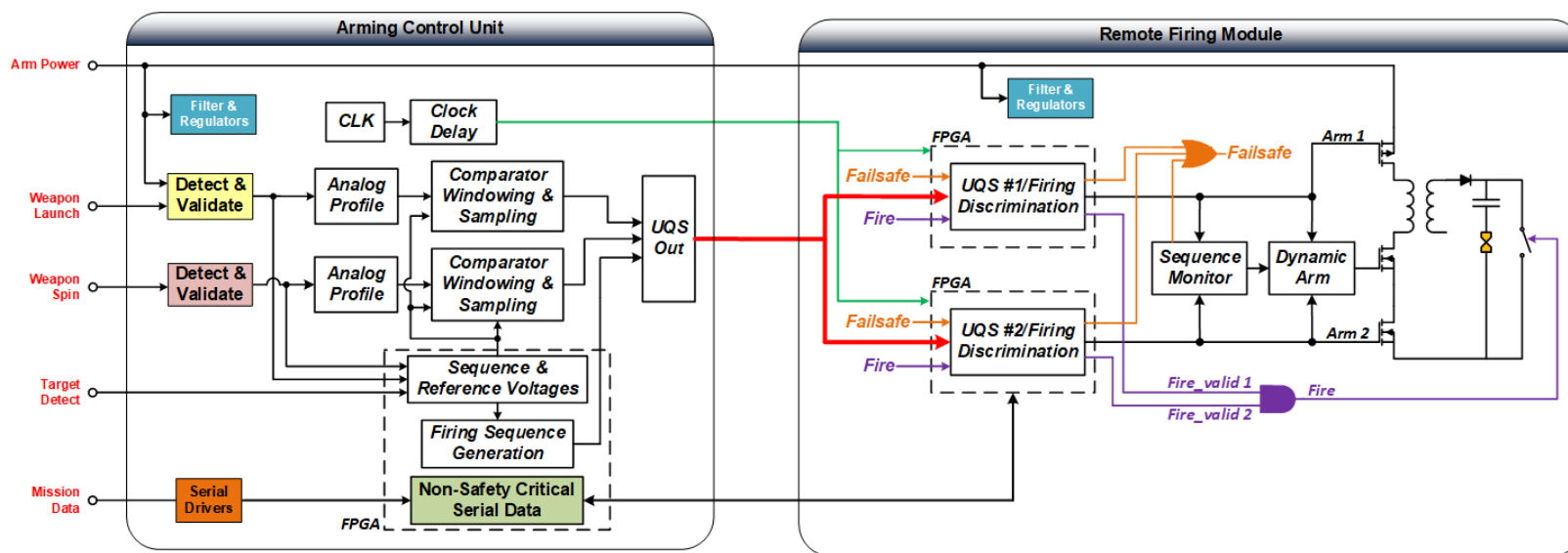

Last but Not Least!!

Let's take a moment to admire this pile of bacon



HTER FOCUSED.



QUESTIONS?

Mark Etheridge
AMRDEC Fuze Office
256-842-7953
mark.e.etheridge2.civ@mail.mil

