

Blast Injuries to People in Buildings

International Explosives Safety Symposium and Exhibition,
San Diego, 6-9 August 2018

Knut B. Holm

Introduction

- A study of blast injuries to people in buildings has been made at FFI.
- A blast wave that hits a building can propagate inside and cause blast injuries.
- The blast wave goes through openings in the building created by the blast.
- Inside the blast wave gets a complex shape, which is important for the extent of blast injuries.
- Building damage can also cause injuries.

- We have estimated the lethality from blast injuries for different blast loads against structures.
- Internal pressures are found by numerical simulations of the blast propagation
- Resulting injury is calculated by a method based on the Axelsson model.
- The results are compared with the lethality from building damage.

Blast injury model

Axelsson's model

- A SDOF model that describes the response of the human chest to a pressure load
- Injury is given by the maximum chest wall velocity, v_c

Stuhmiller's model

- Describes the response of the human chest with a somewhat different model
- Probability of injury = $\frac{1}{1 + e^{-(b_0 + b_1 \ln W)}}$, W = normalised irreversible work

Modified Axelsson's model

- v_c calculated by Axelssons model
- From test data: $W = 2.748 \cdot 10^{-3} (v_c / (\text{m/s}))^{2.089}$
- Lethality calculated according to Stuhmiller

Building model in the simulations

Windows: Rigid, no interaction with the structure

Front wall: Rigid elements, contact forces with adjoining parts of the structure

Other parts: Rigid and immovable

- The blast force on the windows and the front wall elements is resisted only by their mass (65 kg/m^2).
- A similar model of a concrete structure is also used in simulations (500 kg/m^2).



Lykkebo

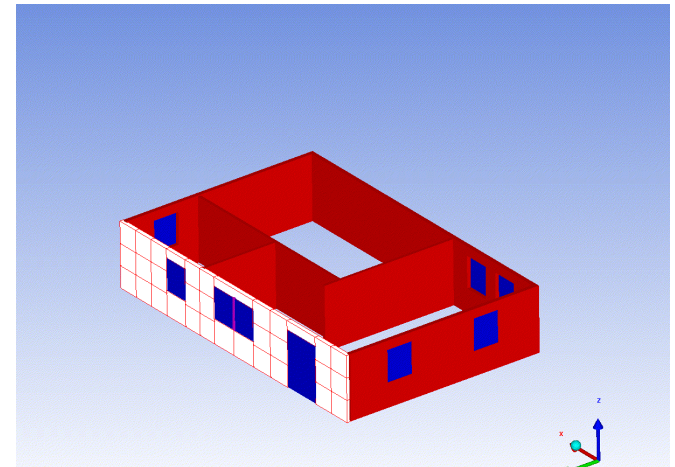

Verification of simulation model

Test with Lykkebo in scale 1:5

Charge: 350 kg Texit (400 kg TNT) at
35 m

Building: Downscaled building parts

Windows: Single pane 2.15 mm

Simulation model:

Downscaled and with adjusted window
thickness



Verification of simulation model

Test with Lykkebo in scale 1:5

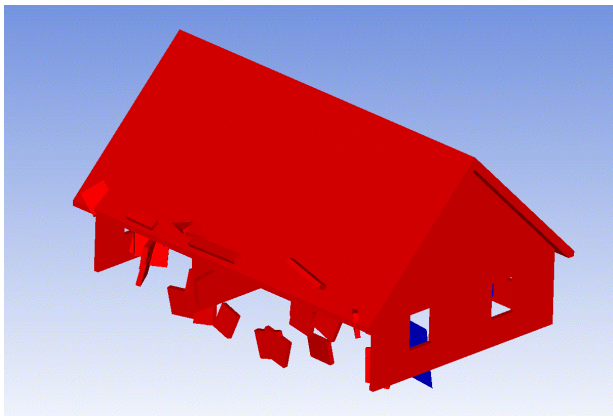

Verification of simulation model

Test with Lykkebo in scale 1:5

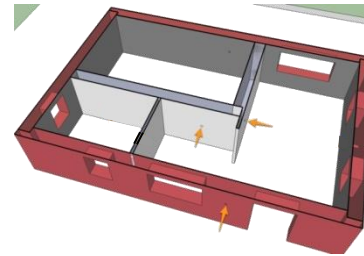
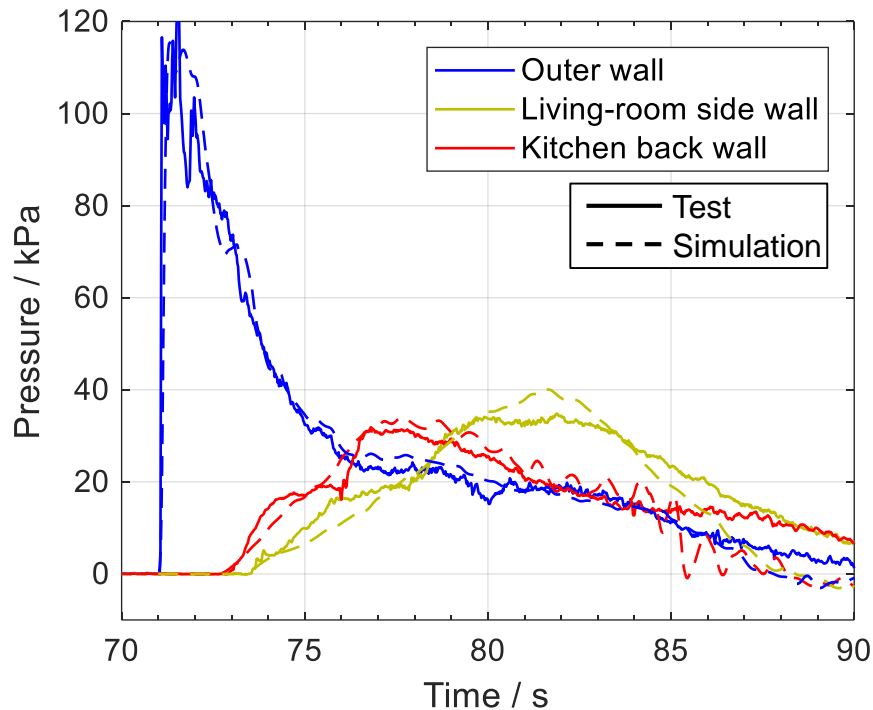

- Very good agreement between simulation and test
- Building model gives a reasonable response to the blast load – structural resistance of the front wall can be neglected
- Simulation with a fixed front wall gives small reductions in the pressures – most of the pressure goes through the window openings

Verification of the window model

Simulation of test with a steel chamber with a window*



*S. O. Christensen, "Blast ingress through failing facades - Experiments with laminated windows," Forsvarsbygg Futura Report: 665/2014, 2014.

- 400 kg TNT at 25 m
- Test: Rigid building and real window
- Simulation: Rigid building and unconstrained rigid window plates
- Good correspondence between simulation and test
- Real windows can be modelled as rigid and freely moving plates

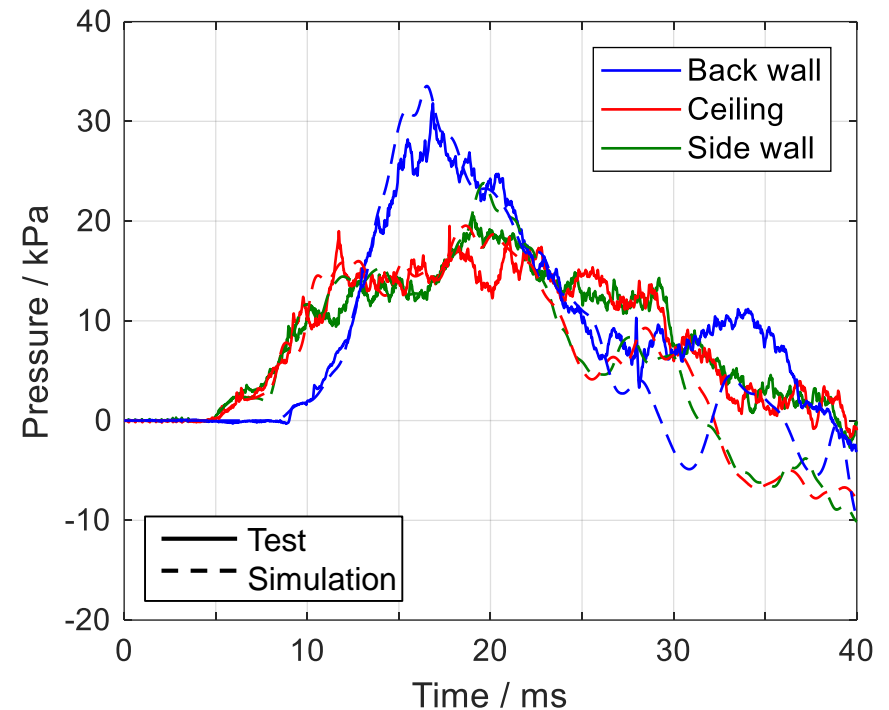

Verification of calculations of pressure propagation

Simulation of tests with Lykkebo in scale 1:25

- Different charges and distances, with and without plates in the window openings
- Test building: Rigid with window plates of plastic or cardboard
- Simulation: Rigid house and unconstrained rigid plates
- Good agreement between simulations and tests
- Pressure propagation is well simulated



Lykkebo in scale 1:25

General calculations

- Pressure-time history is found at positions across the bedroom, kitchen and living-room of the full-scale Lykkebo house by numerical simulations
- The lethality is found from the pressure by the modified Axelsson model
- Average values are found from a series of different pressure loads
- Results are compared with lethality caused by building debris[†]

[†] J.D Chrostowski, P.D Wilde, and W. Gan. "Blast Damage, Serious Injury and Fatality Models for Structures and Windows." ACTA, 2001.

Lethality from blast injuries in wood structures

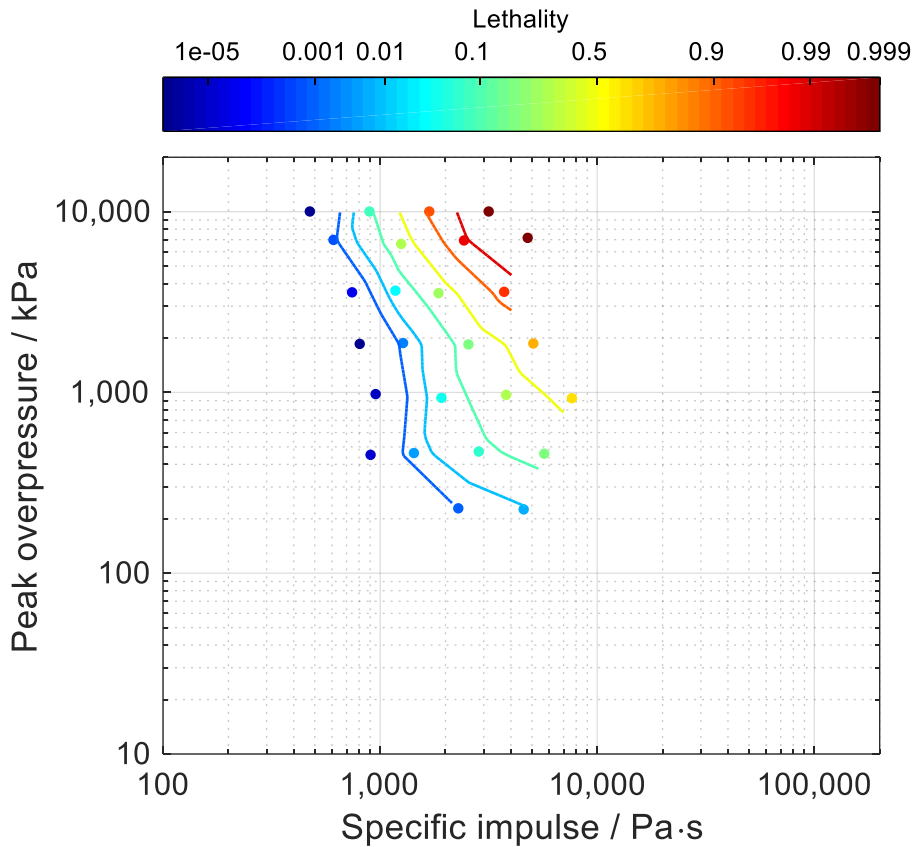

- Contours are fitted to the calculated average lethality values
- Large pressure loads required to give notable lethality values

Lethality from blast injuries in concrete structures

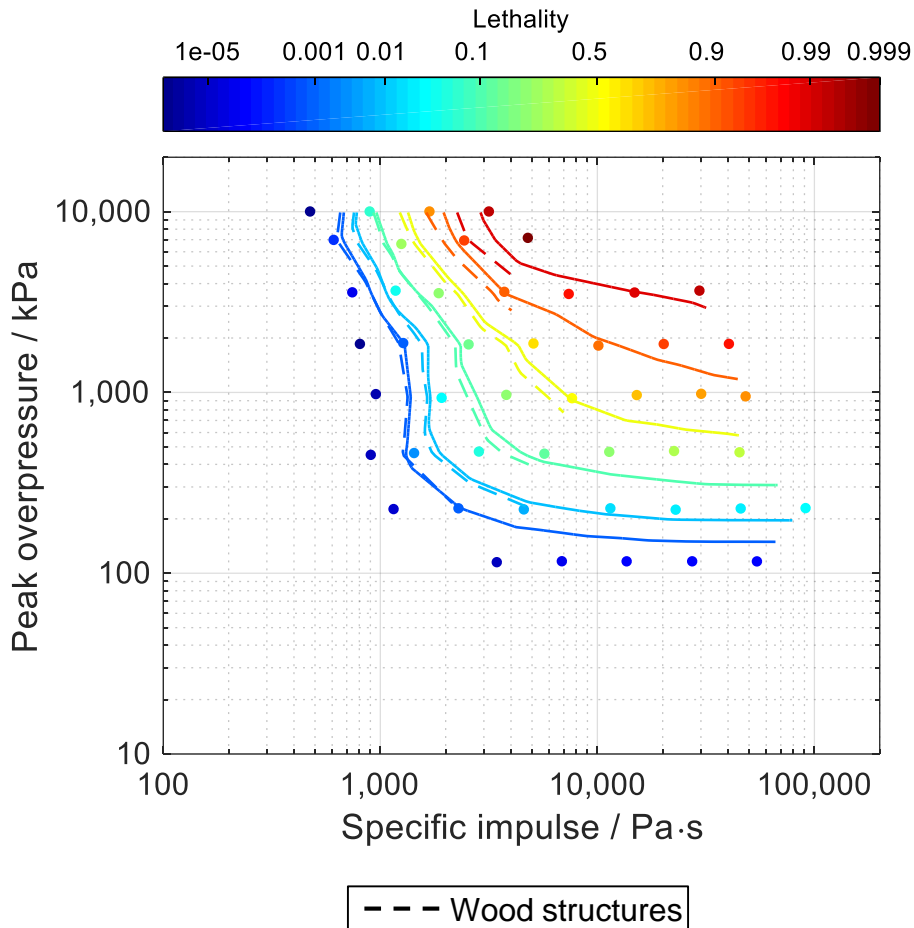

- Small differences between concrete and wood structures – due to differences in wall mass
- Most of the pressure goes through the window openings

Lethality from blast and building damage in wood structures

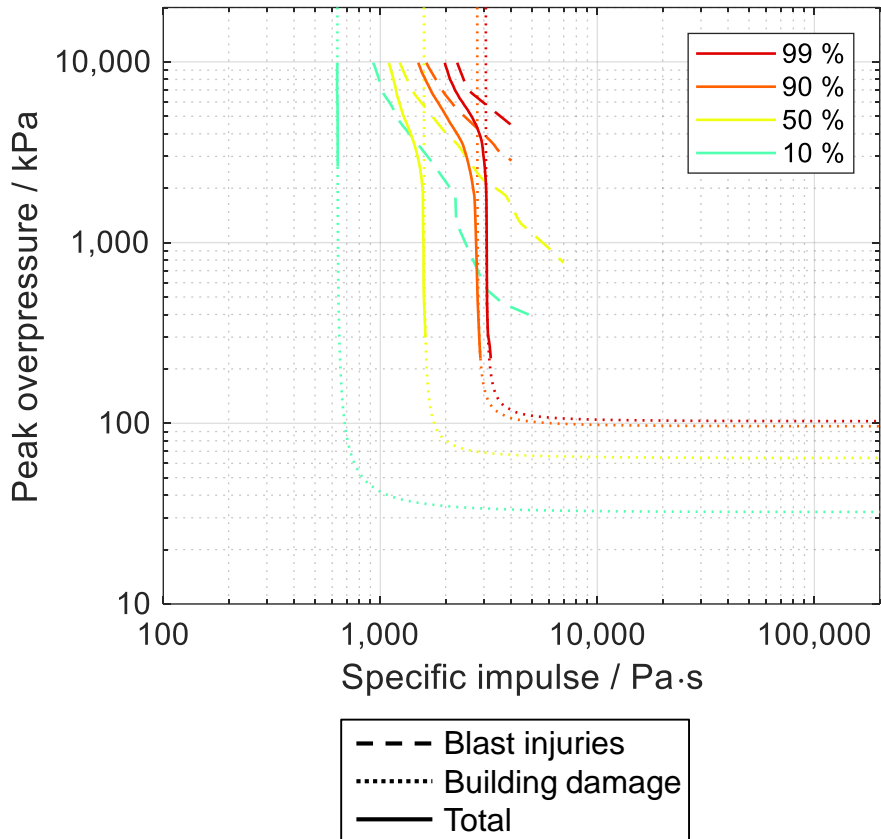

- Blast injuries give a small increase in the total lethality at impulses larger than 1,000 Pa·s and pressures larger than 2-3,000 kPa

Lethality from blast and building damage in concrete structures

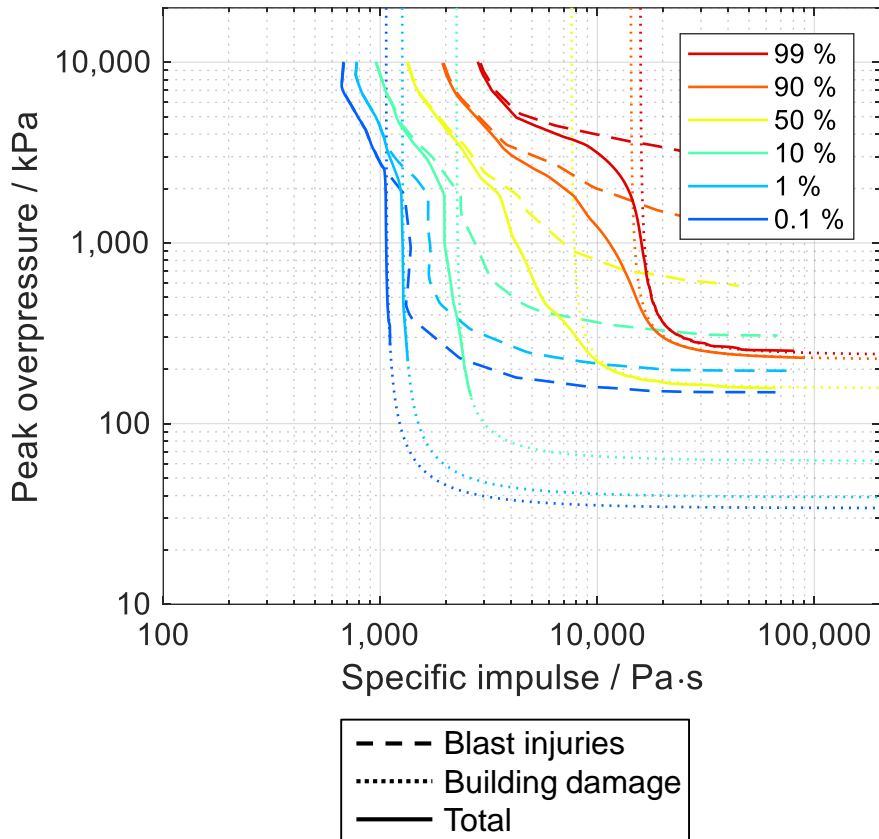

- Blast injuries should be taken into account for higher pressures than 500 kPa

Lethality contours in concrete structures and pressure and impulse values from three charges

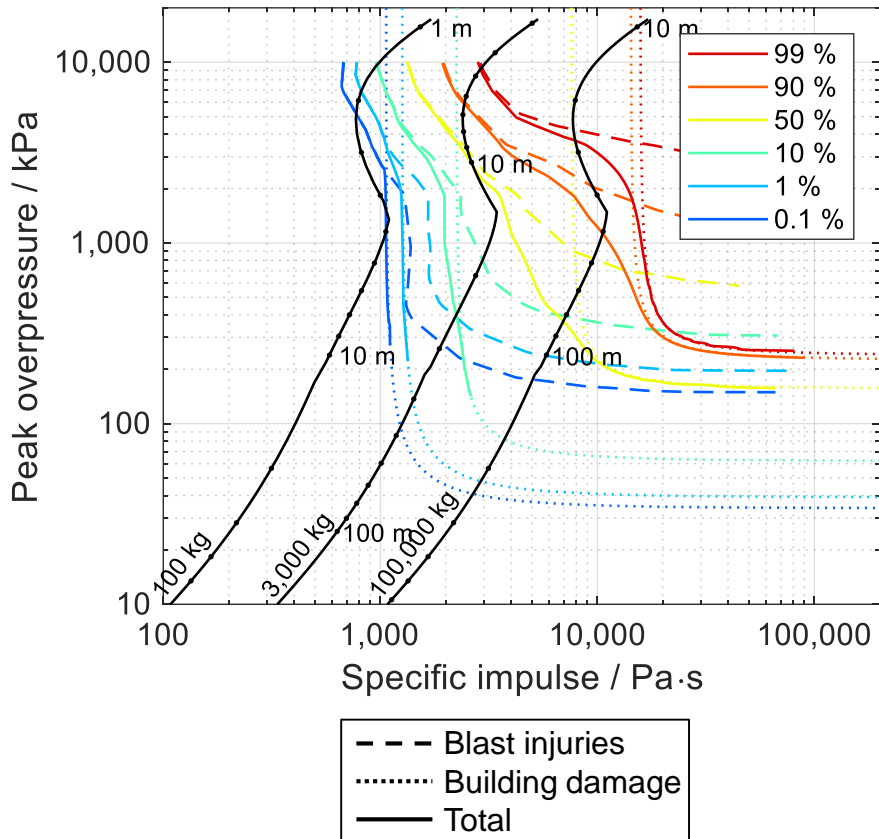

Lethality in concrete structures at different distances from three charges

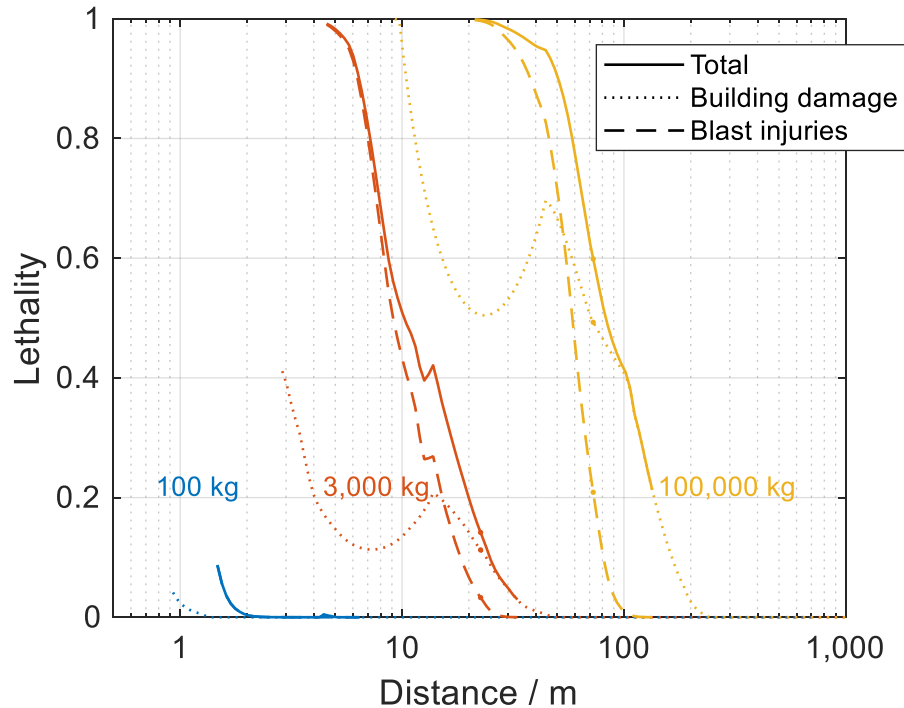

- The lethality is determined by blast injuries at short distances

PI-curves fitted to lethality contours for blast injuries in concrete structures

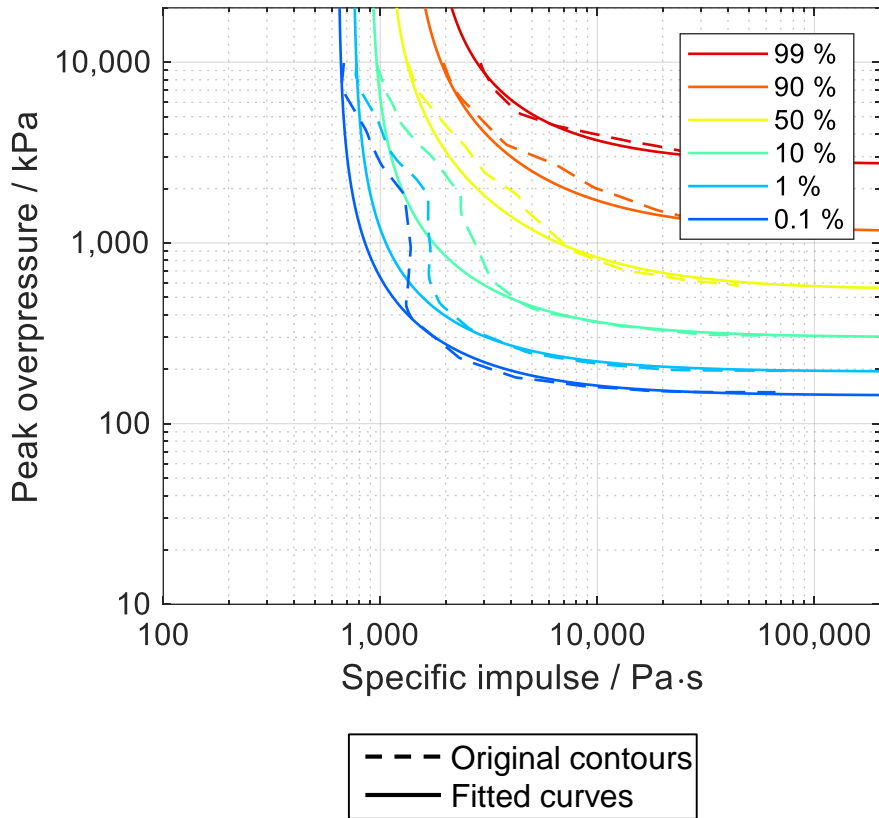

Curve definition:
 $(p - A)(i - B) = C$

	A / kPa	B / Pa·s	C / kPa ² ·s
0.1 %	143	640	180
1 %	194	750	250
10 %	300	900	600
50 %	551	1,060	2,500
90 %	1,150	1,350	4,900
99 %	2,720	1,660	8,145

Lethality in different rooms in concrete structures

- Clear, but quite small differences between the different rooms

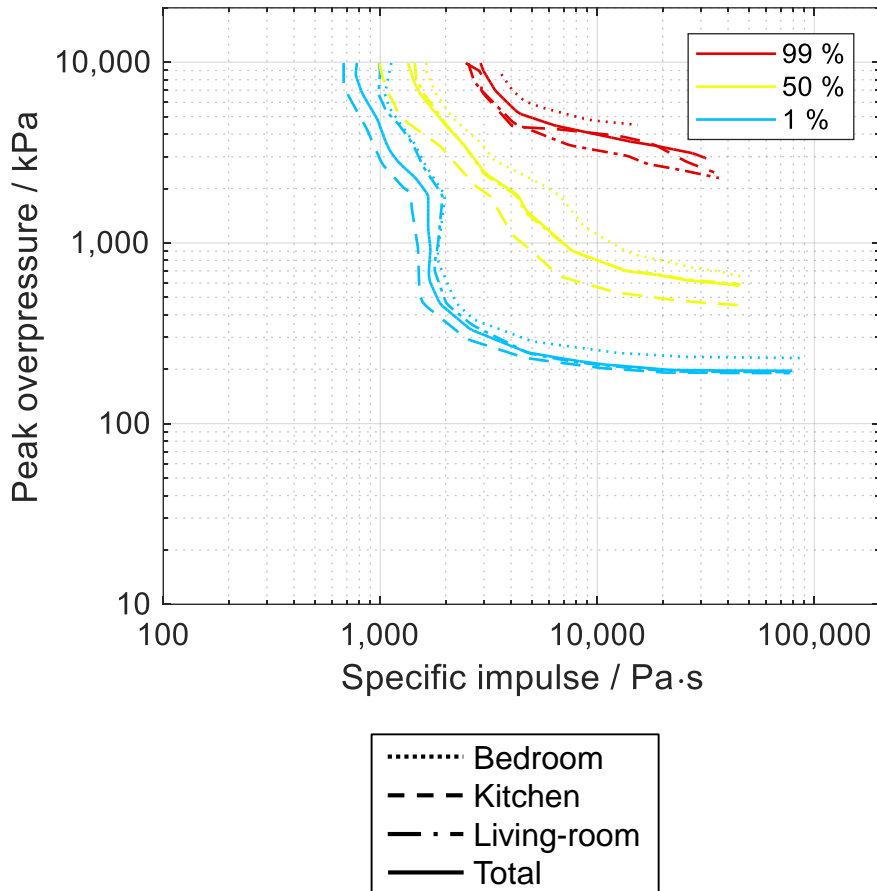

Conclusions

- Simulating pressure propagation into buildings give pressure values in good accordance with experiments.
- In strong structures like reinforced concrete structures, blast injuries are not significant for the lethality to people at incident pressures below 500 kPa. For higher pressures the lethality can be estimated by constructed iso-contours in a *PI*-diagram.
- In light buildings like wood structures the pressure injury can be neglected at incident pressures below 3 MPa.
- The results can give good indications of the extent of blast injuries in buildings of somewhat different designs.