

# PROTECTIVE CONSTRUCTION FOR PERSONNEL IN OPERATIONS BUILDINGS WITH VARYING EXPLOSIVES HAZARDS

2018 International Explosives Safety Symposium & Exposition

John Nevels, PE

U.S. Army Engineering and Support Center, Huntsville

8 August 2018

*"The views, opinions and findings contained in this report are those of the author(s) and should not be construed as an official Department of the Army position, policy or decision, unless so designated by other official documentation."*



US Army Corps  
of Engineers.



# INTRODUCTION

## Criteria Conundrum

- Explosives safety criteria is often confusing or vague
- Full approval can be a lengthy process
- Protective construction, if required, can be expensive

Risk acceptance or waivers are often the most convenient and expedient option, but can have unforeseen and operationally detrimental consequences

DEVIATION APPROVAL AND RISK ACCEPTANCE DOCUMENT (DARAD)					
<small>For use of this form, see DA PAM 385-30; the proponent agency is DAS.</small>					
SITE INFORMATION					
1a. Country: United States	1b. State: <input type="text"/>	2. Service: A - Army	3a. Installation Type: <input type="text"/>		
3b. Installation Name: <input type="text"/>			3c. Type of Site: <input type="text"/>		
DEVIATION INFORMATION					
4. Deviation #: <input type="text"/>	5a. Effective Date: <input type="text"/> <small>(Will auto populate from block 15.)</small>	5b. Expiration Date: 31 DEC 21	6. Deviation From: Ammunition/Explosive (AE) Safety Standards		
7. Type of Deviation: W - Waiver		8a. Number/Title and Paragraph of Requirement: <input type="text"/>			



US Army Corps  
of Engineers.



# EXAMPLE OPERATIONS BUILDING

Operations building with service magazine built to streamline processes by bringing several operations into one building

- Will involve HD 1.1 and HD 1.3 materials
- Some hands-on operations and some hazardous remote operations
- Some operations performed concurrently

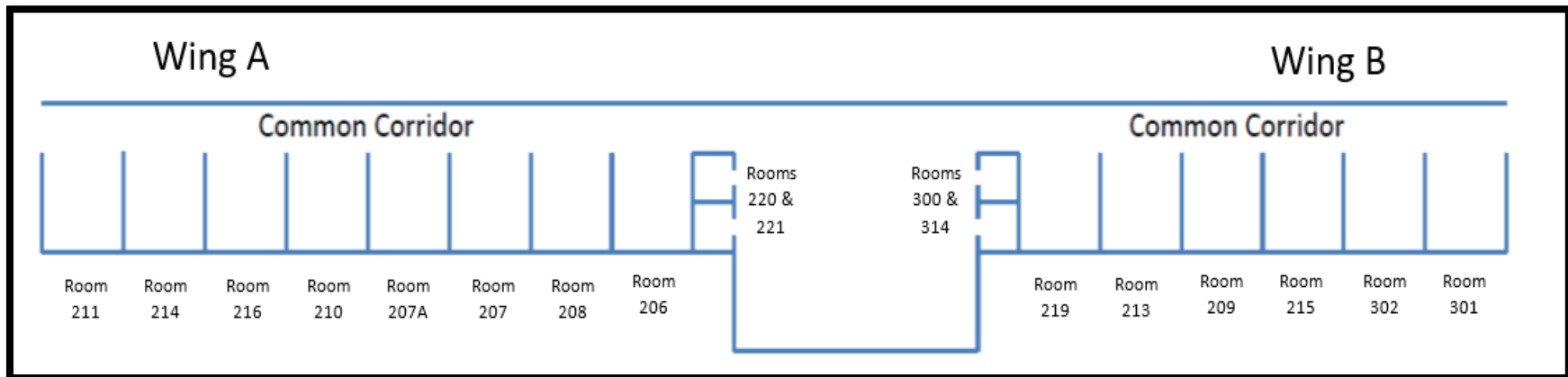

US Army Corps  
of Engineers.



# ORIGINALLY PROPOSED OPERATIONAL INTENT

DoD 6055.09-M V1.E9.3.1.3 requires K24 for remote operator protection

Many combinations of PES and operator locations possible

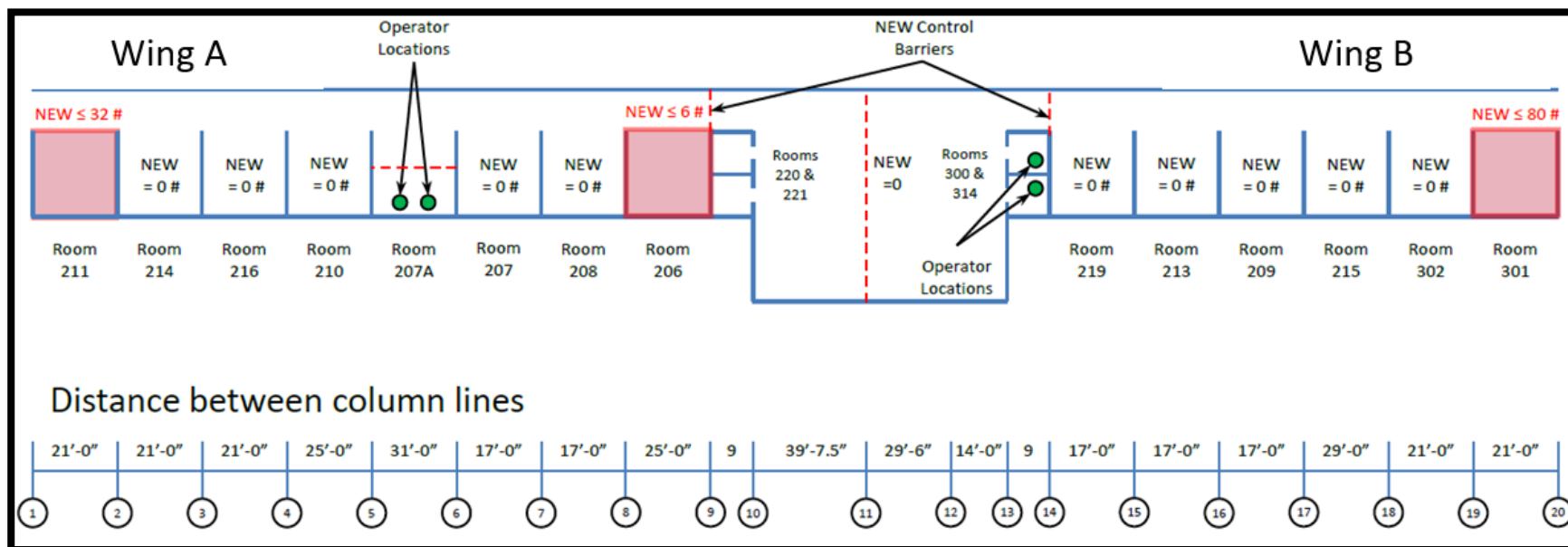

US Army Corps  
of Engineers.



# PROBLEMS WITH ORIGINAL INTENT

QD Tables in DoD 6055.09-M developed for open-air distance between buildings, not internal detonations

- Overpressure tunneling effects possible
- Risk of progressive collapse of common roof structure
- Thermal effects not taken into account

Bringing operations once separated by appropriate distances together inherently increases risk of asset loss associated with single event

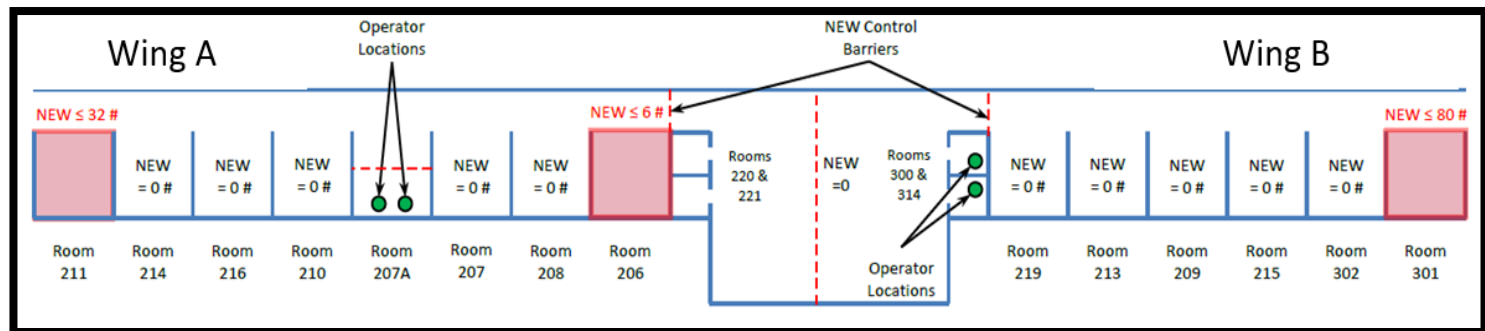

US Army Corps  
of Engineers.



## A DIFFERENT APPROACH

Construction is complete, so major structural and architectural renovations are not an option; the building must be effectively utilized as-is while remaining compliant with current explosives safety standards

Potential scenarios in which accidental explosions could occur must be reduced and managed such that hazards can be comprehensively analyzed and appropriately addressed. Rather than allowing for many combinations of personnel and explosives operations locations, building operations will be generally divided into three scenarios



US Army Corps  
of Engineers.



# OPERATIONAL SCENARIO 1

Hazardous remote operations Bays 301 and 302 involving up to a combined total of 80 pounds of HD 1.1 material

All personnel restricted to Control Rooms 220 and 221

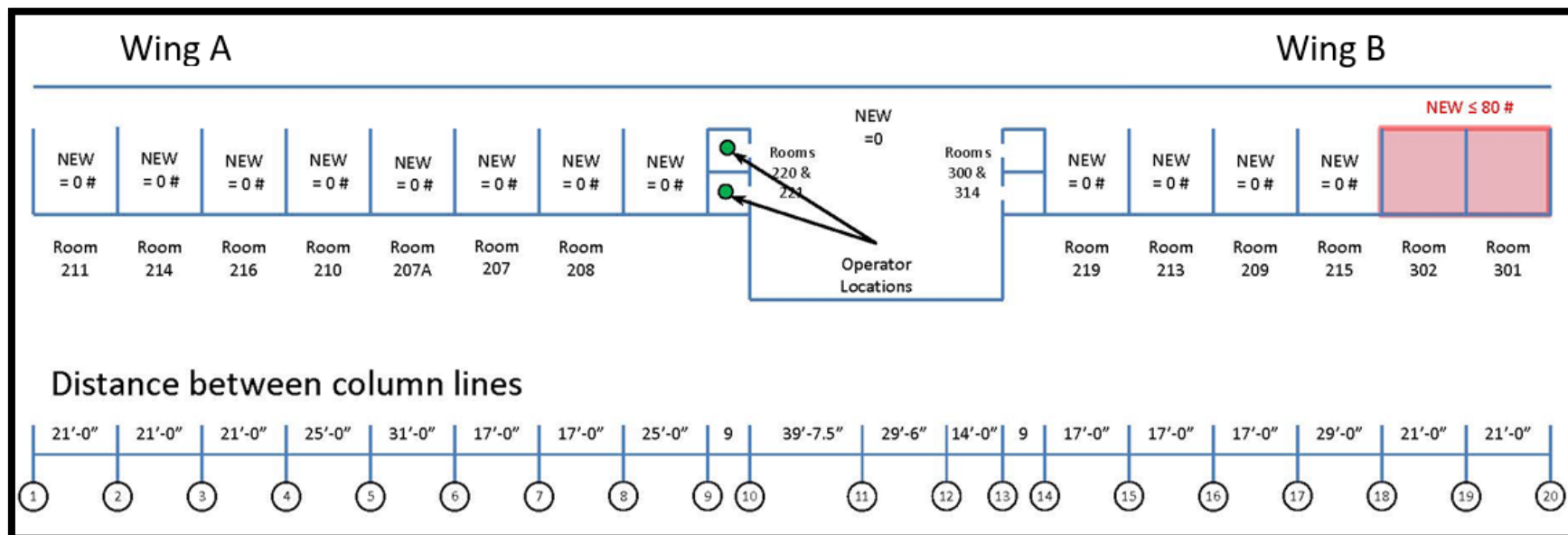

# OPERATIONAL SCENARIO 1 ANALYSIS

BlastX General Room model generated for building

Flexure and shear checked per UFC 3-340-02 for roof and worst-case component (wall between doors; no as-builts)

Penetrations into control room checked for pressure leakage

Control rooms required to be retrofitted with blast doors



US Army Corps  
of Engineers.





## OPERATIONAL SCENARIO 2

Hazardous remote operations Bays 211 and 214 involving up to a combined total of 14 pounds of HD 1.3 material

All personnel restricted to Control Rooms 300 and 314

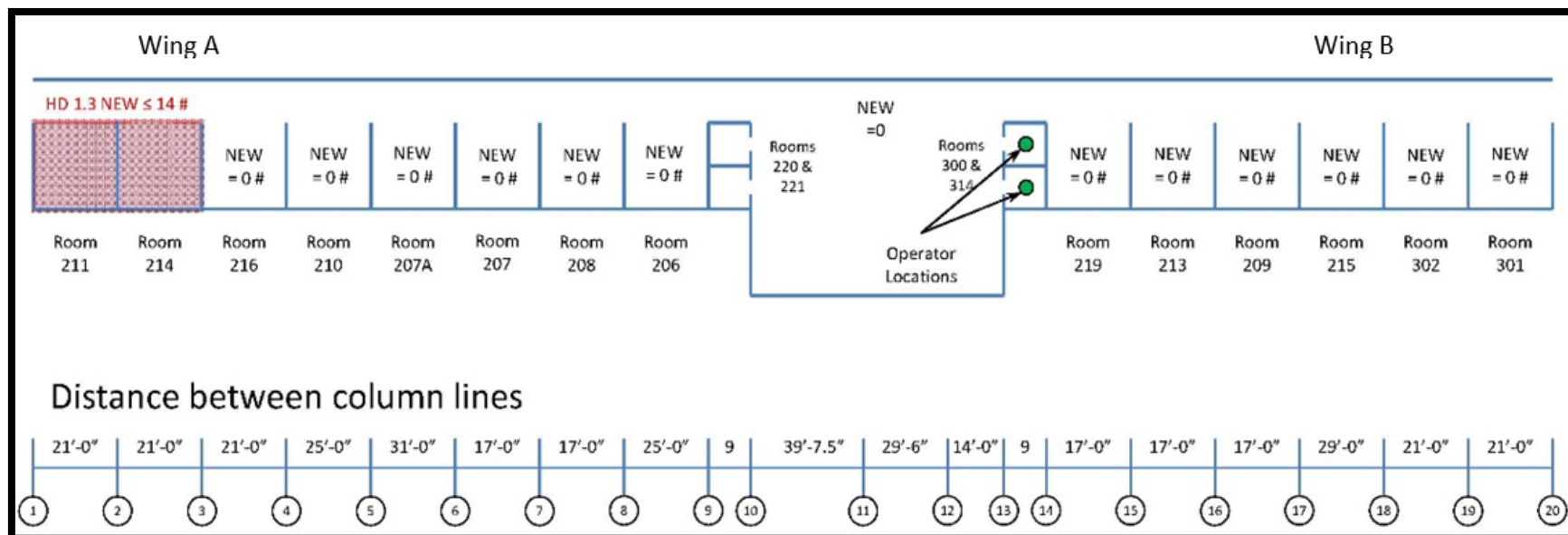

US Army Corps  
of Engineers.



# OPERATIONAL SCENARIO 2 ANALYSIS

DoD 6055.09-M V1E9.3.1.2 criteria of  $t = 200q^{-1.46}$  not adequately predictable, so methodology of HNDED-CS-93-7 (Rev1), *Hazard Division 1.3 Passive Structural Systems Design Guide* used with "Partial Confinement Factor,"  $F_1$ , conservatively assumed to be maximum value of 5

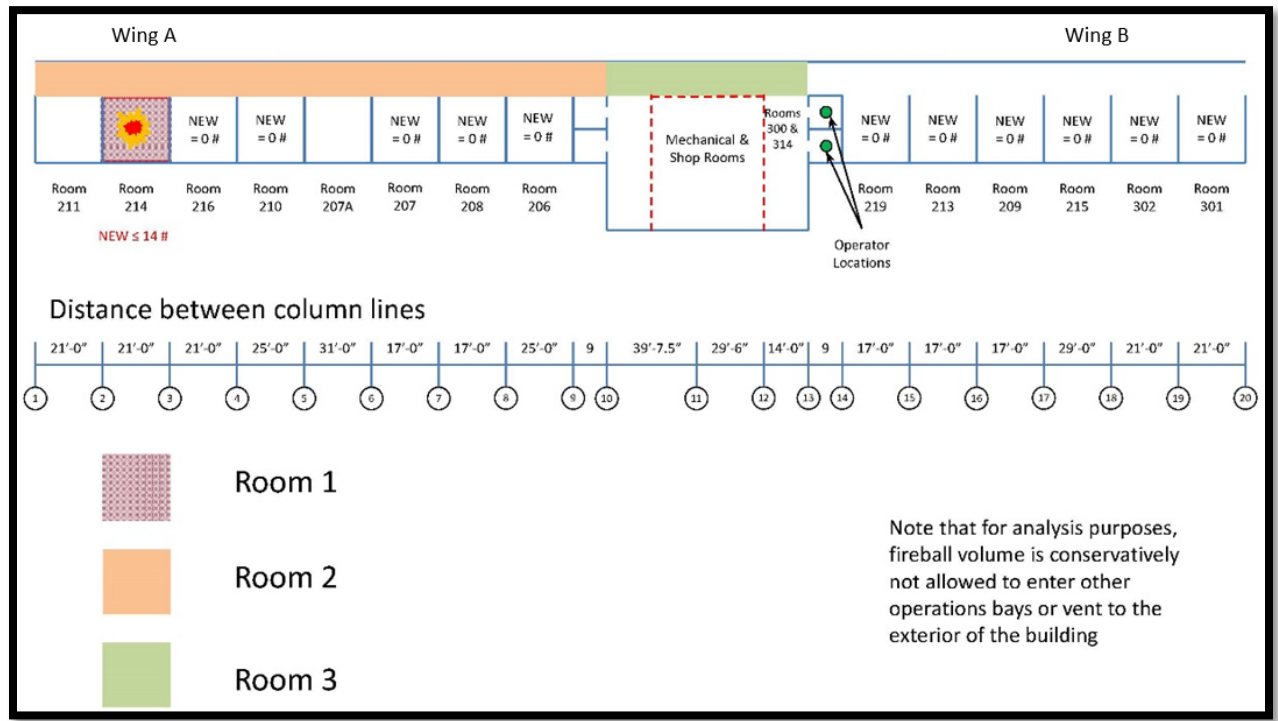

# OPERATIONAL SCENARIO 3

Hands-on operations in both wings with up to 80 pounds of HD 1.1 material permitted in both wings concurrently

Personnel permitted throughout the building

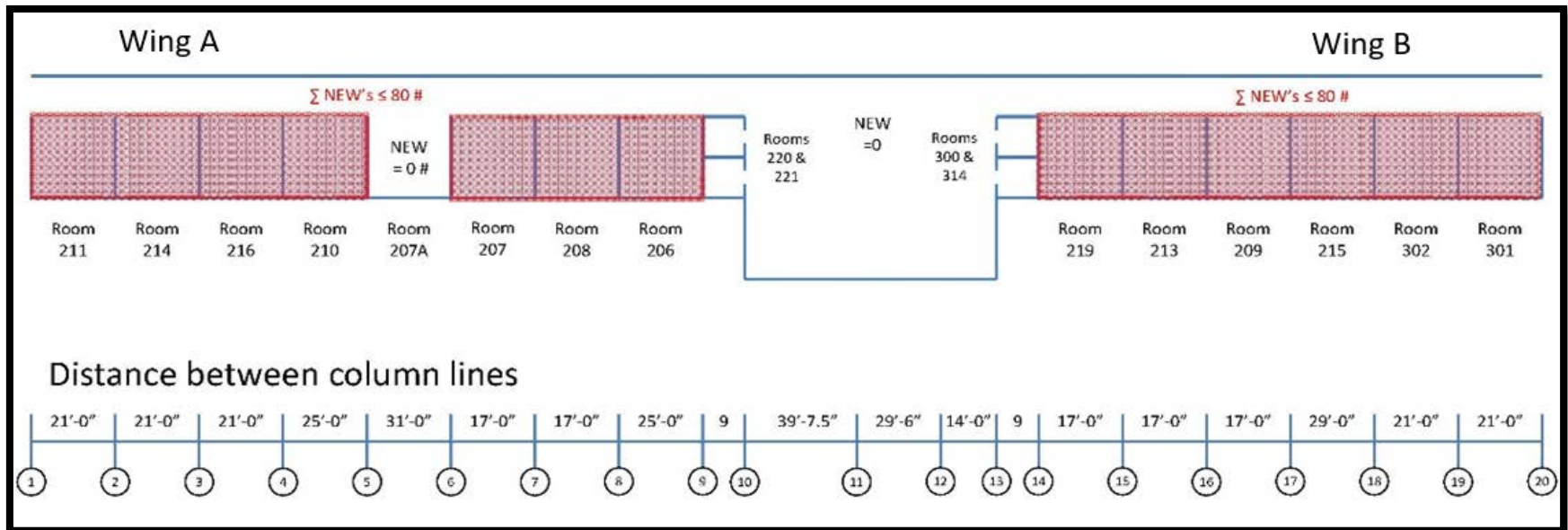

## OPERATIONAL SCENARIO 3 ANALYSIS

No personnel protection required, but to remain within external QD requirements, wings must be sited separately, so prompt propagation must be prevented

Time separation demonstrated using times of arrival generated in BlastX and BEC compared to requirements of DoD 6055.09-M V1.E7.3.2.1



US Army Corps  
of Engineers.



## SUPPORTING SERVICE MAGAZINE

Originally intended to utilize Substantial Dividing Wall (SDW) criteria to allow each bay to be sited individually

Constructed prior to review determining various caveats of SDW memo not met, so building required to be sited as a whole, reducing capacity by 75% based on available external QD



US Army Corps  
of Engineers.



## RISK OF INCREASED ASSET LOSS

Bringing together people and equipment from multiple pre-existing explosives operations inherently increases risk of asset loss beyond the risk formerly acknowledged and accepted by installation leadership.

Signed memorandum required from SES level organizational director acknowledging new risks associated with the building and requiring newly developed SOPs to be followed

MEMORANDUM FOR Department of Defense Explosive Safety Board,  
2461 Eisenhower Avenue, Alexandria, VA 22331-0600

SUBJECT: Acknowledgement of Inherent Risks Associated with the Explosive



US Army Corps  
of Engineers.



# LESSONS LEARNED

## Control rooms in same buildings as hazardous operations present complexities

- Cannot use default distances provided in QD tables for remote operator protection
- Thermal effects cannot be assumed to dissipate in open air between buildings and must be checked
- Additional analysis will be required
  - May be quite extensive or time-consuming
  - May seem overly conservative
  - May indicate the need for costly protective construction

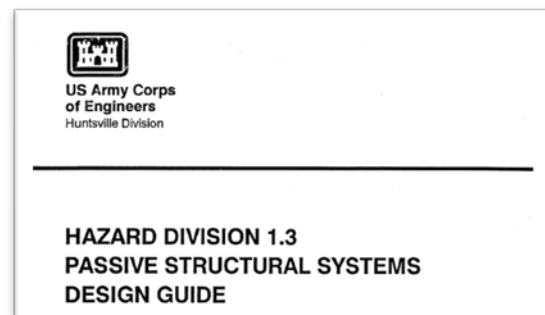

US Army Corps  
of Engineers.



# LESSONS LEARNED

## Proceed with construction without formal approval at your own risk...

- Guidance and buy-in from all levels of the approval chain could have enhanced functionality by allowing higher NEW limits and more permitted concurrent operations
- Time taken to obtain approval up front would likely avoid unnecessary delays associated with subsequently required analyses, negotiations, and retrofit efforts
- ***Frustration can be avoided***

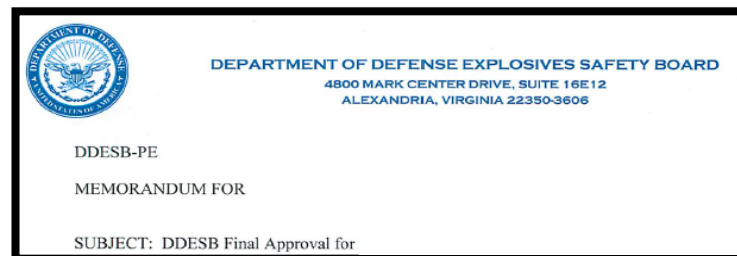

US Army Corps  
of Engineers.





# *Thank You*



*John Nevels*

*U.S. Army Engineering and Support Center, Huntsville*

*(256) 895-1532*

*[John.R.Nevels@usace.army.mil](mailto:John.R.Nevels@usace.army.mil)*



US Army Corps  
of Engineers.

