

Protective Construction for Personnel in Operations Buildings with Varying Explosives Hazards

John Nevels, PE; US Army Corps of Engineers; Huntsville, AL, USA

Keywords: protective construction, concurrent operations, operational scenarios, existing construction, internal detonations, control room

Abstract: Due to limited land available for operations involving explosives and the need for relative ease of access for operators, personnel protection must often be provided through protective construction in accordance with UFC 3-340-02. Some facilities, particularly in the research and development field, present complexities in protective design due to operations involving varying hazard levels, explosive weights, and hazard divisions. Architectural features such as common corridors and user requirements such as operational flexibility serve to further complicate explosives safety compliance.

This paper and presentation discuss a method of demonstrating that a facility meets the personnel protection requirements of DoD 6055.09-M through a combination of administrative controls, blast effects modeling, and structural analysis. Different levels of operational hazards, varying explosive weight requirements, and flexibility to conduct hazardous operations with both Hazard Division (HD) 1.1 and HD 1.3 material are addressed through operational scenarios which individually restrict explosives operations, but which, when applied as needed, allow for both flexibility desired by the user and the ability to discretely analyze each hazard using the methods of UFC 3-340-02 to ensure the appropriate level of protection for personnel within the building during such operations.

Introduction

Over the years, misunderstanding and frustration with existing explosives safety criteria and requirements have resulted in many installations within the Department of Defense (DoD) seeking command acceptance of risks associated with explosives operations rather than obtaining formal approval from their respective Service explosives safety agencies and the Department of Defense Explosives Safety Board (DDESB). Such risk acceptance is generally considered temporary, requiring periodic command review to either ensure that steps are being taken to bring such a non-compliant facility into compliance with DoD and service-level criteria or renew and update appropriate command levels of the risks being accepted. At times, service, agency, or command approaches and philosophies can change, resulting in leadership being less willing to perpetually accept a level of explosives safety risk beyond that of DoD 6055.09-M¹, and subsequently requiring a facility which has been operating under a risk acceptance to be brought into compliance with the criteria either through retrofit efforts or through operational controls and modifications.

This paper provides an example of such a building and its associated service magazine that were constructed without formal DDESB approval and which were expected to operate under command risk acceptance. After construction completion, leadership decided not to accept excessive risk, and the buildings were required to comply with DoD and service-level explosives safety criteria. The example operations building is a research and development (R&D) facility that houses operations with varying hazard levels, operations involving materials from different hazard divisions, and operations originally performed in separate facilities being brought together under one roof. Methods are provided for demonstrating the analytical methods and operational controls that are required to bring the facility into compliance while retaining functional and efficient operational capability.

Analysis Approach

DoD 6055.09-M states that “Protective construction, such as hardening an ES or constructing a PES to suppress explosion effects to provide an appropriate degree of protection, may allow a reduction of the separation distances required by quantity-distance (QD) tables.” Two general methods are available for demonstrating the amount of protection afforded through hardened construction: analysis and testing. Since the analytical approach is used in this instance, the methods of Unified Facilities Criteria (UFC) 3-340-02² and HNDED-CS-93-7 (Rev 1)³ are utilized. Structural and architectural drawings are available, along with descriptions of three operational scenarios that enable these analysis methods to be appropriately applied. Since this information is available, analysis can be used to demonstrate the protective capabilities of the building for the operational scenarios provided, as well as for the above ground storage magazine servicing the building. As per DDESB guidance and the requirements of DoD 6055.09-M,

when an explosives operation within a single building does not satisfy the applicable default separation distances provided in QD tables, protective construction may be used to provide equivalent protection. In such cases, blast analyses must be performed to verify the adequacy of the existing construction. In accordance with UFC 3-340-02, the Net Explosive Weight (NEW) used in analyses incorporate a 20% safety factor. To account for thermal hazards, the methodology provided in HNDED-CS-93-7 (Rev 1) is utilized, and the prompt propagation time thresholds established in DoD 6055.09-M are utilized.

Facility Description

The main building consists of two wings of operations bays, Wing A and Wing B, with an area between housing non-explosives operations (mechanical room and shop room) and four control rooms. The operations bays are separated by reinforced concrete dividing walls extending through the roof, and the common corridor is made of metal stud walls. The operations bays have metal stud walls closing them off from the corridor as well. To account for fragmentation hazards external to the building, it can be assumed that there is a fragment retention wall outside the building behind all of the explosives operations bays. A schematic of the building can be seen in Figure 1 below.

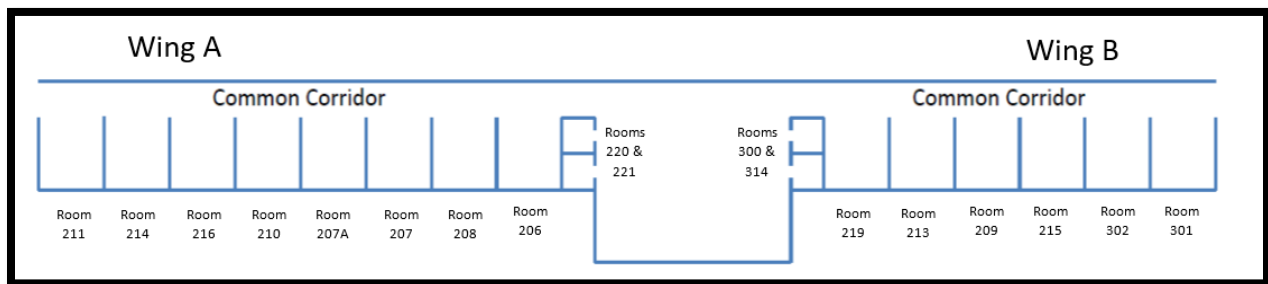

Figure 1: Operations Building Schematic

Original Operational Intent and Associated Concerns

The original intent of the building was to perform various hazardous remote operations with both Hazard Division (HD) 1.1 and HD 1.3 material concurrently with operators controlling them at different locations throughout the building so long as K24 overpressure distance was provided for operators, which would be administratively controlled.

For example, if 32 pounds of HD 1.1 material was located in Room 211, 6 pounds of HD 1.1 material was located in Room 206, and 80 pounds of HD 1.1 material was located in Room 301:

$$K24_{32lbs} = 24 \times 32lbs^{1/3} = 77feet$$

$$K24_{6lbs} = 24 \times 6lbs^{1/3} = 44feet$$

$$K24_{80lbs} = 24 \times 80lbs^{1/3} = 104feet$$

SOPs in place would require both explosives and personnel be more than 5 feet inside of their respective bays (i.e., greater than 5 feet from the wall separating the bay from the common corridor), and NEW control barriers would be in place to prevent personnel from entering the K24 arc for any given operation. By restricting the personnel controlling operations in Rooms 211 and 206 to Room 207A and restricting those controlling the operation in Room 301 to Rooms 300 and 314, while maintaining the SOPs described above, the QD requirements for personnel protection for hazardous remote operations have been met per V1.E9.3.1.3 of DoD 6055.09-M, and the presence of multiple reinforced concrete walls between any PES and personnel can be assumed to defeat any fragmentation or debris hazards. Such an operational scenario is illustrated in Figure 2 below.

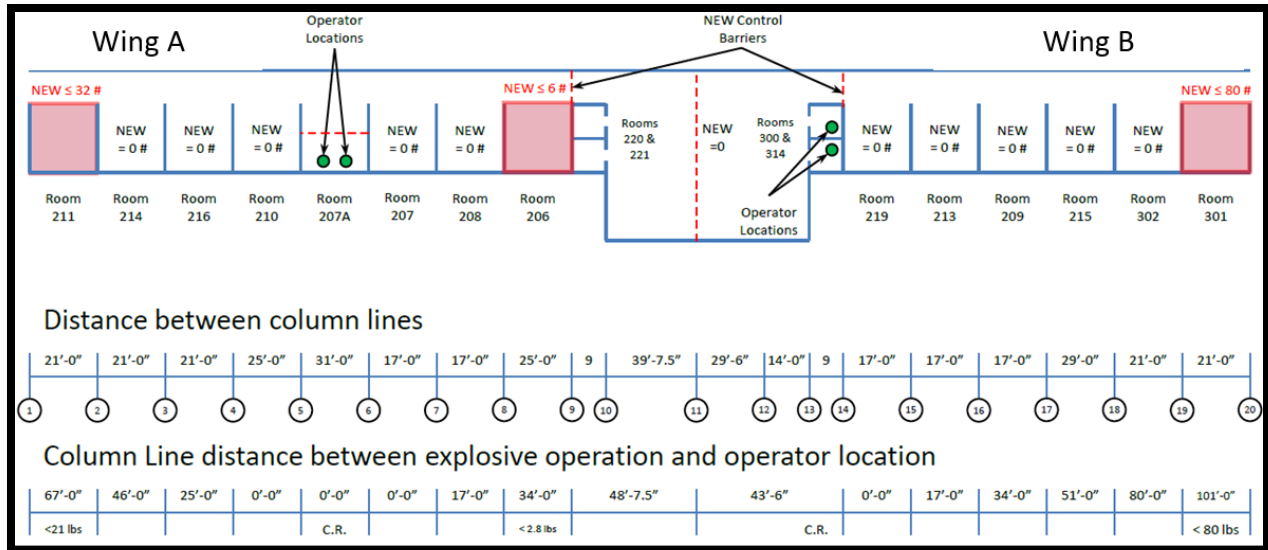

Figure 2: Potential Concurrent Operations Using External QD Requirements

Using the same logic presented above, many operational scenarios could be devised in which operators were kept at distances beyond K24 for multiple hazardous remote operations being performed concurrently. However, the QD tables presented in DoD 6055.09-M are representative of open-air distances at which incident overpressures are reduced to permissible levels; K24 represents the distance at which incident overpressure is reduced to 2.3 psi. For an internal detonation, confinement, multiple reflecting surfaces, and unknown or unpredictable levels of venting result in “tunneling” effects, which can cause overpressures to remain significantly above the permissible exposure for personnel at distance greater than those listed in QD tables such as K24. If such tunneling effects were to occur, operators at the locations shown in Figure 2 above could be exposed to hazardous overpressures, and when analysis is performed using BlastX software, it is seen that personnel in Room 207A would, in fact, be exposed to incident pressures above 2.3 psi. Additionally, thermal effects have not been taken into account, so any HD 1.3 material being used (or any HD 1.1 material that was accidentally initiated but did not go high-order) could present significant hazards to personnel as well. With such hazards yet to be addressed, the scenario listed in Figure 2 does not meet the personnel protection criteria, and the same could potentially be true with many other scenarios utilizing K-factor distances within a single building.

Further complicating the acceptability and approvability of such a building is the newly established close proximity of operations that were once housed at separate facilities. Formerly, Wing A operations and Wing B operations were performed in different building spaced at acceptable distances from one another; consequently, if an accidental explosion were to occur, only assets related to one operation would be damaged or lost. In bringing multiple operations together under one roof, the potential for asset loss due to a single accident is increased.

As construction is complete, major structural and architectural modifications are not an option. Clearly, a different approach must be taken to most effectively utilize the building while remaining compliant with explosives safety standards.

Revised Approach

To ensure that all personnel are adequately protected against all explosive hazards, the potential scenarios in which accidental explosions could occur must be reduced and managed such that hazards can be comprehensively analyzed and appropriately addressed. Rather than allowing for many combinations of personnel and explosives operations locations, building operations can generally be divided into three scenarios. The first operational scenario is the only one in which hazardous remote operations are being conducted on HD 1.1 material. In this scenario, operations involving up to a combined total of 80 pounds of NEW in Rooms 301 and 302 of Wing B will be performed.

During this operation, no other rooms of either wing will have any explosives in them, and the only personnel remaining anywhere in either wing of the building will be the operators, who will be controlling the operation from Rooms 220 and 221; these personnel are to be protected from accidental detonations. All explosives in this scenario will be HD 1.1 material. A schematic of this operational scenario can be seen in Figure 3 below.

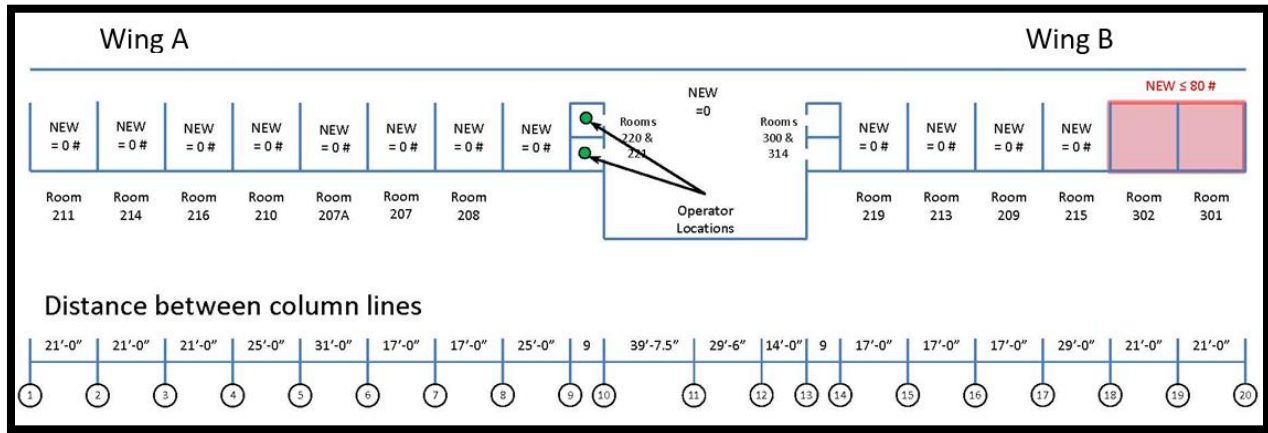

Figure 3: Operational Scenario 1; HD 1.1 Hazardous Remote Operations

The second operational scenario is the only one in which operations involving Hazard Division 1.3 material are being conducted. In this scenario, up to a combined total of 14 pounds of NEW will be in Rooms 211 and 214 of Wing A. During this operation, no other rooms of either wing will have any explosives in them, and the only personnel remaining in either wing of the building will be the operators, who will be controlling the operation from Rooms 300 and 314. A schematic of this operational scenario can be seen in Figure 4 below.

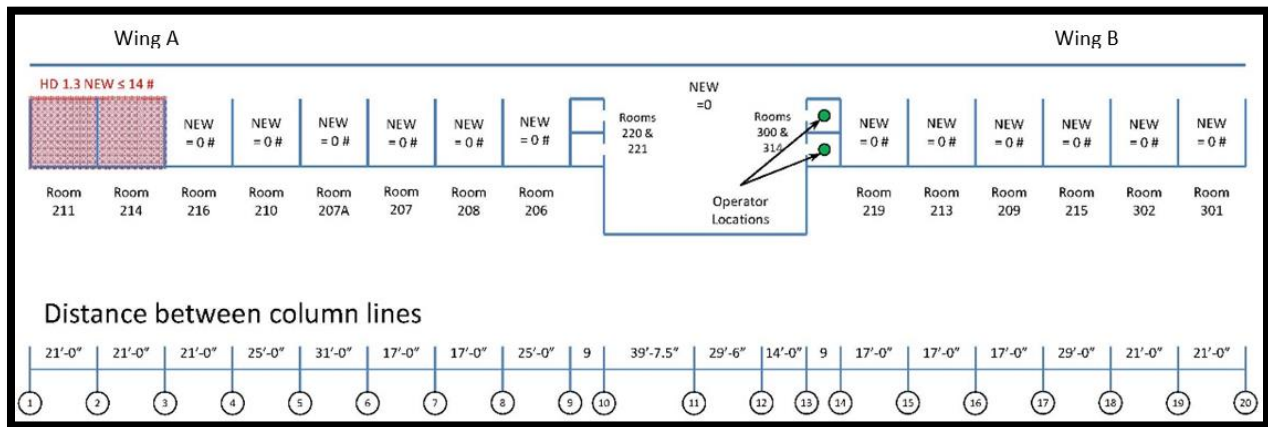

Figure 4: Operational Scenario 2; HD 1.3 Hazardous Remote Operations

The third operational scenario covers the remainder of explosives operations permitted in the building. All operations in the third scenario are hands-on, and operators will be in rooms throughout the building. In this scenario, up to 80 pounds of NEW will be permitted in both Wing A and Wing B; no explosives will be between column lines 9 and 14. As will be discussed below, the wings are to be sited separately in order to maximize explosive capacity of each wing while maintaining appropriate QD separation from other areas and facilities, so prompt propagation will be shown not occur between the two wings in the event of an accidental detonation. A schematic of this operational scenario can be seen in Figure 5 below.

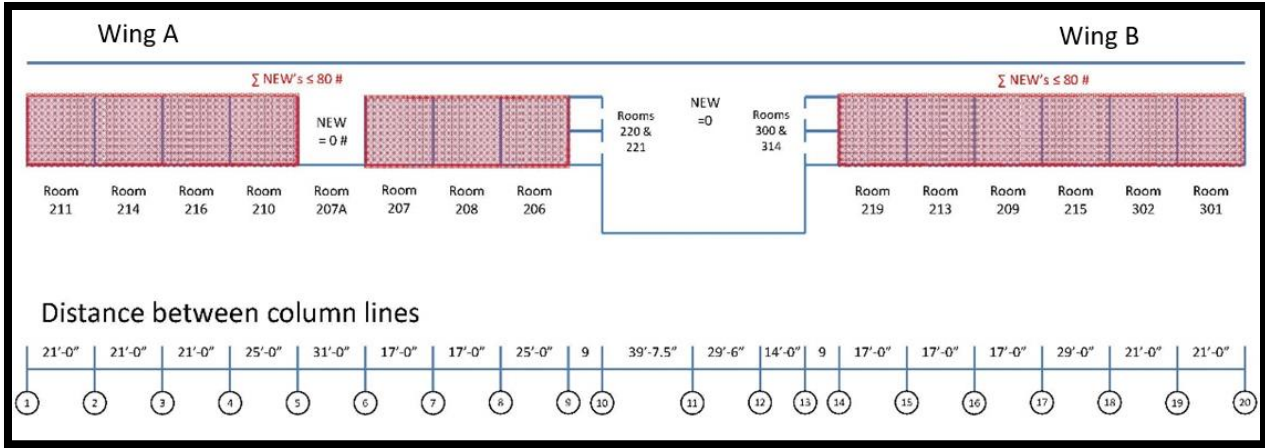

Figure 5: Operational Scenario 3; Hands-On Operations

Supporting Service Magazine Issues and Resolution

The service magazine was constructed to support operations in the main building with the intent of utilizing Substantial Dividing Walls (SDWs) to prevent prompt propagation and thereby allow for each bay to be sited individually. It consists of four bays, with a reinforced concrete roof and dividing walls and a common corridor connects the bays. Due to an insufficient vent area ratio as well as all walls being heavier than 10psf, the construction of the service magazine does not meet the requirements of the most recent DDESB memorandum providing updated guidance for SDWs, and the building must therefore be sited as a whole rather than per-bay. As with the operations building, the service magazine was constructed prior to approval, so extensive structural and architectural retrofits are not an option, and the siting is based on the existing structure. The result is a 75% decrease in capacity of the magazine based in available external QD. A floor plan of the service magazine can be seen in Figure 6 below.

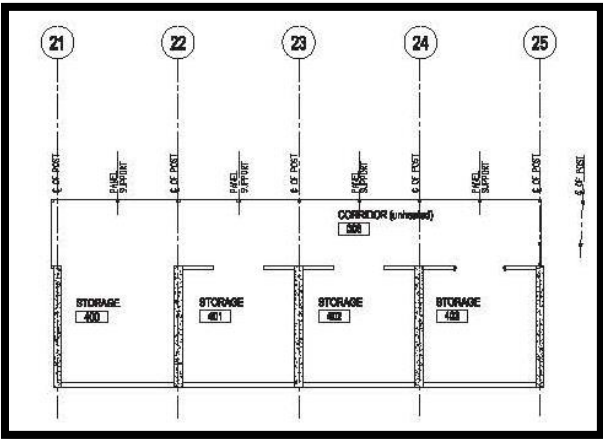

Figure 6: Service Magazine

Operational Scenario 1 Analysis

To verify the safety of the first operational scenario presented, the main building has been analyzed to ensure that remote operators are afforded protection from the accidental detonation of 80 pounds NEW in either Room 301 or 302. Protection Category 1 is required of the components of Rooms 220 and 221, which is where personnel will be during operations.

To model the blast environment, the building was modeled in BlastX using the “general room” option. The charge was conservatively assumed to be in Room 302, three feet from the wall closer to the control rooms and 3 feet from the edge of the room adjoining the corridor. An array of targets was placed on the wall in which the control room doors are located, and a second model placed an array of targets on the roof of the control room. Various dividing walls and roof section, as well as sections of the corridor wall were defined as having the potential to fail and vent using the FACEDAP wall failure model in BlastX for their respective wall types, dimensions, and thicknesses. An illustration of the BlastX model is shown in Figure 7 below.

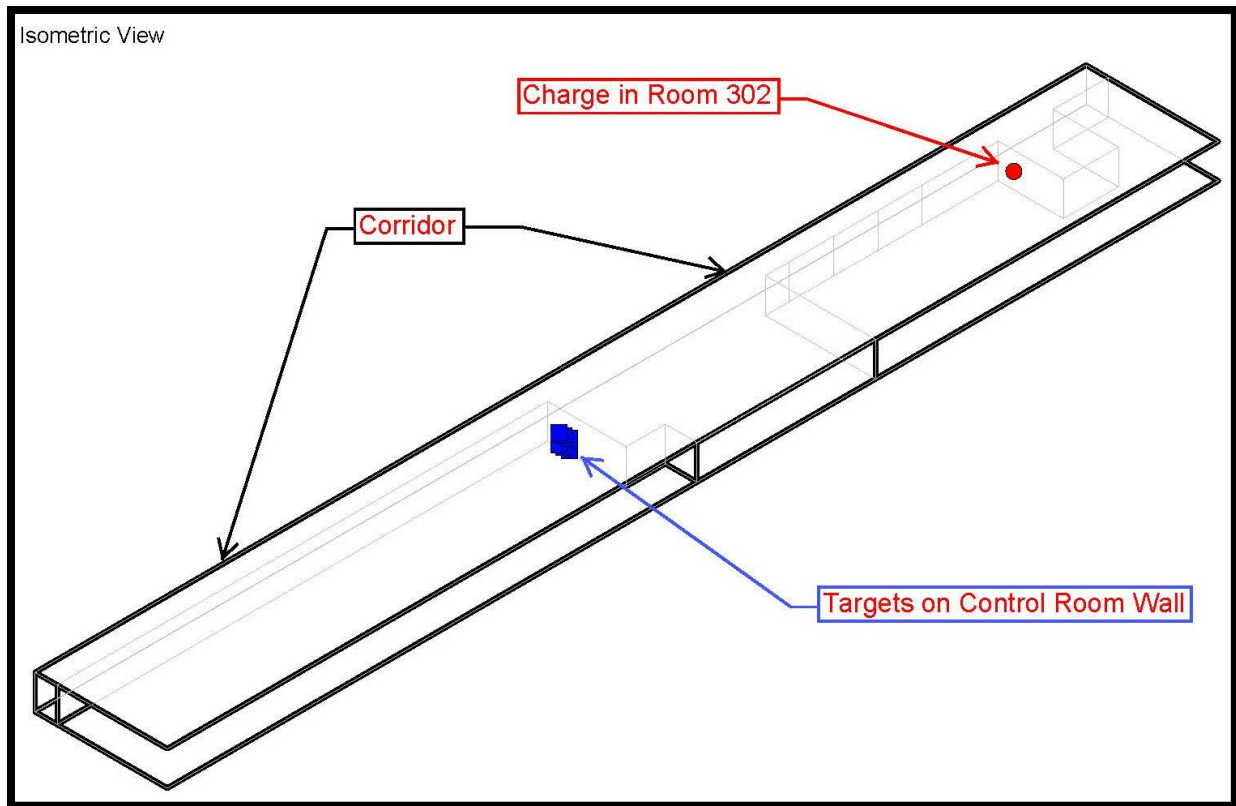

Figure 7: BlastX Model of Operations Building

To ensure that the worst case loading scenario was considered, the model was also run with walls defined to represent the walls of the mechanical and shop rooms potentially planned to be placed in the common area between the two wings. This additional model showed that pressures and impulses were higher when these walls were neglected, so the analysis proceeded without them.

Using results from the BlastX model, the worst case pressure and worst case impulse from the array of targets were conservatively used in lieu of an average pressure and impulse over the array to load the control room wall for analysis.

As can be seen in facility drawings, the doors between Rooms 220 and 221 are close together, so the section of wall between the two doors is loaded by its tributary area from both doors and is analytically only capable of acting in one direction (vertical). This was assumed to be the worst case loading of any wall components and was selected for analysis. As-built and design drawings detailing the reinforcement in the control room walls are not available; however, for analysis purposes, reinforcement has been conservatively assumed to be #4 rebar spaced at 12” on-center, which is the least robust reinforcement of any concrete wall for which details are available.

The analysis shows that the flexural response is well within the limitations of Protection Category 1, and both the diagonal tension and direct shear capacities exceed the shear demands. To ensure conservatism in the shear

analysis, the ultimate resistance was calculated for the most robustly reinforced walls for which details are available, which included #5 rebar spaced at 8" on-center. Analysis shows that the concrete diagonal tension and direct shear capacities exceed the demands with this assumption as well. As it is highly unlikely that the control room walls are more lightly reinforced than #4 @ 8" or more heavily reinforced than #5 @ 8", the walls have been shown to be sufficiently designed.

It should be noted that the walls under consideration are existing walls, and since the analysis shows that shear and flexural capacities far exceed demands even assuming lighter reinforcement, the risk of a sudden failure is negated, so the components' reinforcement ratio being less than the prescribed minimum is not a concern. It should further be noted that the analysis assumes that the doors to the control room are capable of withstanding the blast effects; recommendations for blast door requirements are provided in the conclusion of this paper.

The roof of the control rooms was analyzed in similar fashion to the walls, with the worst case pressure and impulse from the target array being used to load the roof. As was the case in the wall analysis, the flexural response is well under the limitations of Protection Category 1, and both the diagonal tension and direct shear capacities exceed the demands.

The installation is planning on placing penetrations in the side of the control room walls to allow for HVAC ductwork to enter. The worst-case location of the planned penetrations will connect the control room with the corridor along column line 9. To model this, a target was placed in the BlastX model at this location to determine the pressure history on the exterior of this wall. A simplified triangular load history was conservatively assumed for analysis purposes, and the iterative methods of Section 2-15.5 of UFC 3-340-02 were then used to determine the pressure buildup through this penetration. Analysis showed that the maximum pressure buildup inside the control room, P_i , is 0.062 psi, which is well below the levels permitted for control personnel inside; blast valves will therefore not be required.

Since the components under the worst case loadings have been shown to adequately withstand the overpressure effects, and multiple 12-inch thick reinforced concrete walls between any potential explosion and the control rooms intuitively mitigate any fragmentation risk, then any operators in Control Rooms 220 and 221 can be considered to be adequately protected from an accidental detonation during operational scenario 1.

Operational Scenario 2 Analysis

The second operational scenario involves up to 14 pounds NEW of HD 1.3 material. To ensure that personnel are not subjected to thermal effects from an accidental deflagration, in the absence of approved methods that are more up to date, the methodology found in HNDED-CS-93-7 (Rev 1), *Hazard Division 1.3 Passive Structural Systems Design Guide* were followed.

The procedures in HNDED-CS-93-7 (Rev 1) entail determining the fireball volume relative to the rooms in which the fireball occurs, then determining proportions of the fireball entering any vents in the room, then repeating the procedure in each room and through each vent until enough room volume is present to fully contain the fireball. To ensure conservatism, the fireball analysis of the example building only allowed the fireball to expand into the room volumes represented by Room 214 (the room in which the event was assumed to occur), the common corridor, and the portion of the room between column lines 10 and 15 not occupied by mechanical and shop rooms. The fireball volume was not allowed to expand into any additional bays or vent outside of the building. Further conservatism was provided by assuming the maximum value of the "Partial Confinement Factor," F_1 , of 5. An illustration of the room progression assumed for analysis is shown in Figure 8 below.

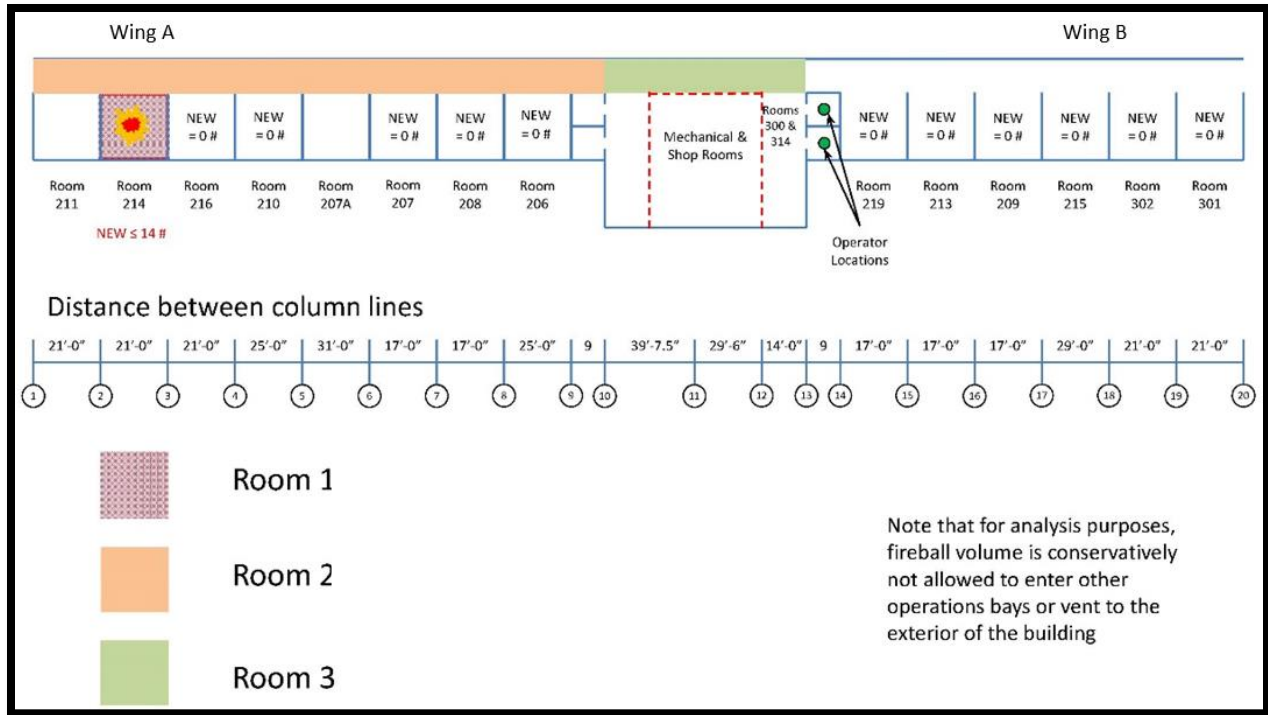

Figure 8: Operational Scenario 2 Analysis Illustration

Analysis shows that sufficient volume is present in the rooms listed above for the fireball to fully expand. Operators located in Control Rooms 300 and 314 should be adequately protected from thermal hazards associated with this operational scenario. It is recommended, however, that blast doors with the same performance criteria as those recommended for Control Rooms 220 and 221 be provided for Rooms 300 and 314; this will provide further, more robust protection from thermal hazards.

Operational Scenario 3 Analysis

The third operational scenario entails siting each wing for hands-on operations with up to 80 pounds NEW of HD 1.1 material. Personnel protection for the operators is not required; however to allow each wing of the building to be sited separately, prompt propagation must be shown to not occur. Prompt propagation can occur due to either overpressure or fragmentation/debris from one detonation impacting another stack of explosives within a short enough period of time to both cause a second detonation whose blast wave coalesces with the first, effectively causing the two NEW's to be additive.

As can be seen in the scenario schematic shown in Figure 5 above, multiple 12" thick reinforced concrete walls will be between explosives in the two wings at all times. These walls will prevent primary fragments from a detonation in one wing from impacting explosives in the other. Since multiple walls are present between the closest potential locations of explosives (a minimum of two 12" thick walls, with over 101 feet between), the risk of secondary debris causing prompt propagation is negated as well.

To demonstrate that the pressure wave from a detonation in one wing would not cause prompt propagation to the other wing, the minimum time requirements for stack separations, as defined by DoD 6055.09-M V1.E7.3.2.1, were compared to the time of arrival of a blast wave generated by a full detonation of the maximum NEW in one wing at the nearest point at which explosives could be present in the other wing. The time of arrival was calculated both in the Blast Effects Computer (BEC) and BlastX assuming this minimum standoff. As added conservatism, in the BlastX model, both the donor and receiver charges were assumed to be out in the corridor at column lines 9 and 14,

respectively, which will not be the case per facility SOP's. Analysis assumptions and relative locations can be seen in Figure 9 below.

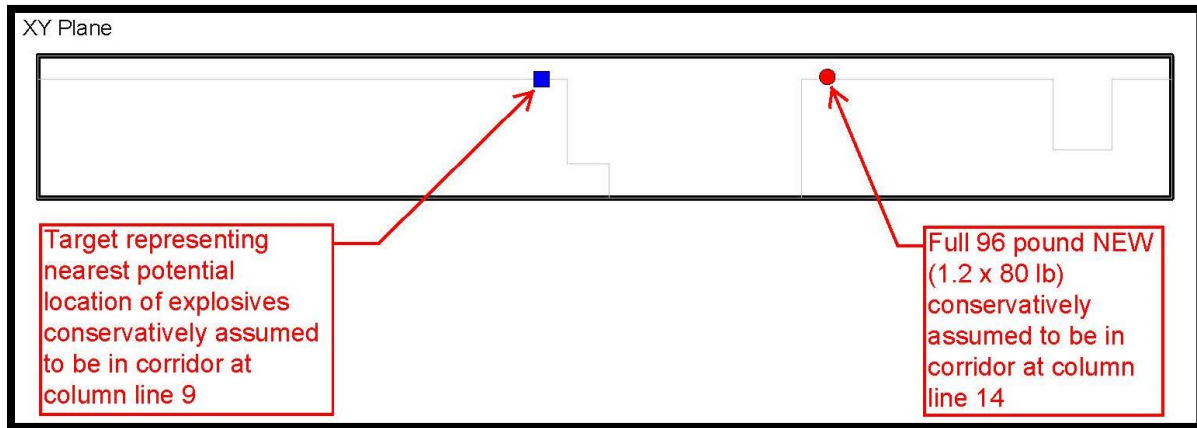

Figure 9: Operational Scenario 3 BlastX Analysis Illustration

The Blast Effects Computer and BlastX models calculated times of arrival of 64.1ms and 60.06ms, respectively; both of these are far longer than the worst-case requirement from DoD 6055.09-M, which is 25.64ms for explosive stacks positioned axially. This demonstrates that prompt propagation will not occur due to the pressure waves coalescing. The two wings of the building can therefore be sited individually for 80 pounds NEW each.

Control Room Blast Doors

As mentioned above, to ensure the safety of the operators, blast doors will be required for Rooms 220 and 221, and they are highly recommended for Rooms 300 and 314. The blast doors should be designed and installed by a competent blast door manufacturer into the existing opening such that they swing outward from the control rooms and seat into the frames in the event of a detonation. The doors should be designed to withstand a triangular loading with a sudden rise time with a peak overpressure of 4.04 psi and duration of 37ms, resulting in a peak impulse of 74.7 psi-ms. Prior to installation, the size and spacing of concrete reinforcement should be checked and confirmed, either through ground-penetrating radar (GPR) methods or destructive testing with appropriate infill. This is to ensure that the anchorage of the door does not damage the structural integrity of the supporting wall and to ensure that design assumptions used in the analysis of the wall supporting the door are correct. The design of the blast doors, including door hardware, interface, and anchorage to the surrounding door frame, should be reviewed by a competent Government blast agency prior to installation as well.

Inherent Risks of Consolidating Operations Buildings

Regarding the added risk of asset loss due to bringing once-separate operations into a common building, a signed memorandum was required from the SES level organization director. This memorandum officially documents and acknowledges the inherent risks associated with explosives research and the added risk for several operations to become affected in the event of an accidental explosion. The memorandum further states that all technical requirements and added SOPs of such an analysis as described herein are to be followed and may only be changed with SES level concurrence.

Conclusions and Lessons Learned

Given the analysis and reasoning presented above, it would be recommended that the service magazine be sited for the maximum amount of explosives permitted by QD siting criteria for the entire building as a single PES, and it would be recommended that the example operations building be sited to operate in the three operational scenarios listed above with the respective NEW limits described for each operational scenario. The operations building has

been shown to adequately protect personnel during operations in which protection is required, and it has been shown that prompt propagation will not occur when explosives are present in both wings of the building.

Two major lessons learned are illustrated in this example. The first is the risk of proceeding with the construction of an explosives operations building without first obtaining formal DDESB and service-level approval. Guidance and buy-in from all tiers of the approval chain could have enhanced the functionality of the building by potentially allowing for higher NEW limits and more permitted concurrent operations, resulting in more efficient use of taxpayer funds and reduced frustration by the users and installation leadership. As a corollary to this, the time taken to incorporate such guidance and buy-in and then obtain formal approval would likely avoid the unnecessary delays associated with subsequent analysis, negotiation, and minor retrofit efforts.

The second lesson learned is more technical but is quite broadly applicable to a broad range of potential operations building designs. The inclusion of control rooms in the same building as the hazardous remote operations with which they are associated triggers the requirement for extensive additional analysis. In the example presented above, if the control rooms were placed exterior to the building, the tunneling effects described would no longer be applicable, the K24 overpressure distance would be all that was required for overpressure concerns, no blast doors would be required, and a much larger quantity of HD 1.3 material would be permitted. Rather than the construction of four hardened control rooms, restricted operations, and substantially reduced NEWs, a simple QD arc along with fragment and debris protection would be required. It is highly recommended that these lessons learned be heeded in future construction projects involving hazardous remote operations.

References

1. *DoD 6055.09-M "DoD Ammunition and Explosives Safety Standards: General Explosives Safety Information and Requirements"* (Department of Defense, date varies by volume).
2. *UFC 3-340-02 "Structures to Resist the Effects of Accidental Explosions"* (Department of Defense, 2008, incorporating Change 2, 2014).
3. *HNDED-CS-S-93-7 (Rev 1) "Hazard Division 1.3 Passive Structural Systems Design Guide"* (US Army Corps of Engineers, Huntsville Division, 1994)