

# **Enhancing Constructability and Reducing Construction Costs of Reinforced Concrete Blast Cells**



**William H. Zehrt, Jr., PE**

**US Department of Defense Explosives Safety Board**

**2018 NDIA International Explosives Safety Symposium and Exposition  
San Diego, CA – August 9, 2018**



# Presentation Outline

---

- Introduction
- Problem Statement
- General Recommendations
- Blast Design
- Detailing and Construction
- Conclusions
- Questions???



# Introduction

---

US Department of Defense Explosives Safety Board (DDESB) was established in 1928 after a major explosives accident at the Naval Ammunition Depot in Lake Denmark, New Jersey. The accident virtually destroyed the depot and caused heavy damage to adjacent Picatinny Arsenal and surrounding communities, killing 21 people and seriously injuring 53 others.





# Introduction

---

- DDESB Mission: Provide objective advice to the Secretary of Defense and Service Secretaries on matters concerning explosives safety and prevent hazardous conditions to life and property on and off Department of Defense (DoD) installations from the explosives and environmental effects of DoD-titled munitions.
- Minimum protection requirements for personnel and property provided in DoD 6055.09-M, “DoD Ammunition and Explosives Safety Standards.”
  - Preferred approach: Use default separation distances in DoD 6055.09-M to provide required protection.
  - Alternate approach: If unable to provide default separation distance(s), design protective construction IAW UFC 3-340-02, “Structures to Resist the Effects of Accidental Explosions,” to provide equivalent protection.



# UFC 3-340-02 Overview

---

- Proponent: DDESB
- Primary Objective: Establish design procedures and construction techniques to prevent or delay an explosion propagation between adjacent bays or buildings, to protect personnel against death or serious injury, and to protect property.
- Applicability: Facilities used for development, testing, production, storage, maintenance, modification, inspection, demilitarization and disposal of DoD-titled ammunition and explosives.
- Reinforced concrete blast design requirements based on extensive detonation tests in typical Service explosives operating and storage cells.
- First issued in 1969 as Army TM 5-1300/NAVFAC P-397/AFR-22.
- Heavy emphasis on continuously supported reinforced concrete walls/slabs.



# Problem Statement

---

- Protection levels and blast design requirements applied by different user communities (e.g., antiterrorism and explosives safety) vary markedly.
- Antiterrorism
  - Focus on prevention of mass casualties
  - Threats are typically far range, lower NEW, external detonations
  - Minimal consideration of munition fragmentation and thermal hazards
- Explosives Safety
  - DoD 6055.09-M defines protection requirements. During higher risk remotely controlled operations, permissible personnel exposure to blast overpressures, fragments and thermal hazards are limited.
  - Reinforced concrete design requirements in UFC 3-340-02 are based on ACI 318 Building Code; supplementary requirements applied when needed (based on detonation tests).
  - UFC 3-340-02 applies more rigorous design requirements when a wall/slab must withstand a close-in and/or an internal detonation.



# Protective Structure Categories (Explosives Safety)

---

- Shelters
  - Protect from external detonation
  - DoD 6055.09-M's default separation distances for thermal hazards usually satisfied
- Barriers
  - Prevent propagation of an explosives reaction
  - Typically constructed of reinforced concrete and/or earth
- Containment Structures
  - Mitigate blast effects from an internal detonation
  - Typically constructed of continuously supported reinforced concrete walls/slabs
- The remainder of this presentation considers the design of typical Service partial blast containment cells



# Typical Service Partial Blast Containment Cell

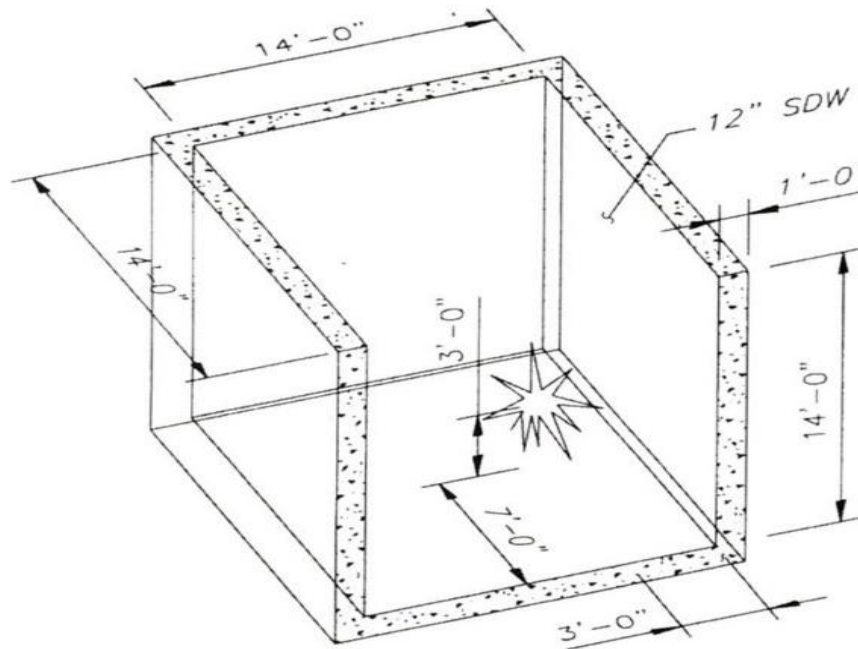

- Cell dimensions vary with the explosives operation; typical interior lengths/widths range from 10-feet to 25-feet.
- Cells constructed in 1950s and 1960s usually have frangible exterior wall and roof that are inset 3-feet; side walls are sloped to match roof.
- Later construction (designed IAW TM 5-1300) retains frangible exterior wall, but roof is often a hardened reinforced concrete slab.





# General Recommendations

---

- Use typical Service partial containment cell configuration
  - Initially developed in 1950s from explosives accident data
  - Provides protection from both an accidental HD 1.1 detonation and an accidental HD 1.3 (mass fire) ignition
  - Locate all doors/penetrations in frangible, exterior elements
- Venting is your friend, but vent to exterior only
- UFC 3-340-02 design procedures work together; may not “shop” other design manuals/codes for less rigorous requirements



# Constructability is Crucial!

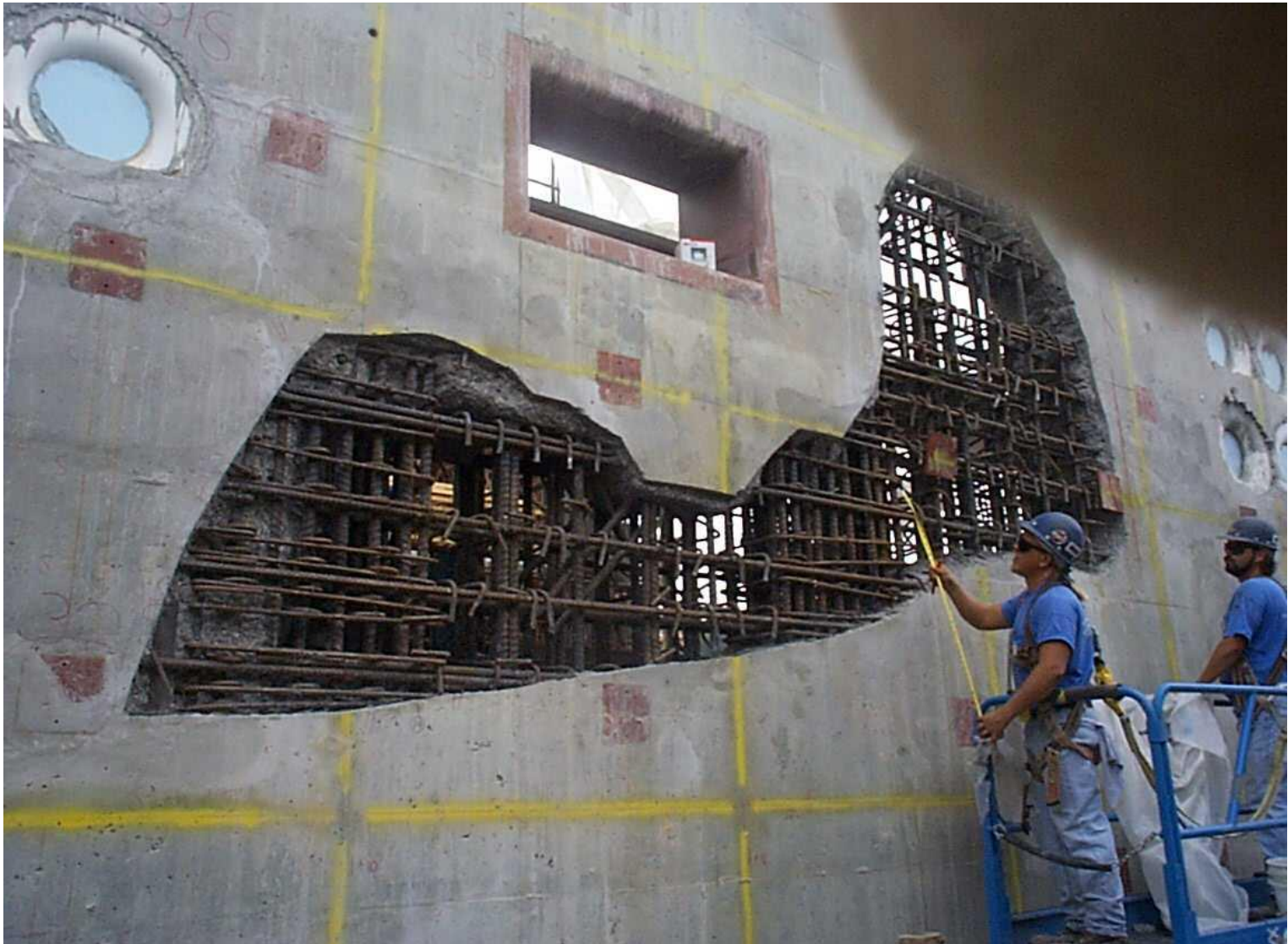



# Blast Design - Flexure

---

- Design to meet applicable support rotation limit under design blast loading (normally 2-degrees for personnel protection)
- Diagonal tension, direct shear and direct tension design requirements are based on a wall/slab's ultimate resistance. Do not overdesign!
- Always consider increasing the concrete thickness before increasing the steel reinforcing ratio
- Verify that design concept is constructible
  - Evaluate hook diameters and lap splice development lengths
  - Consider added congestion in wall/slab joints and pilasters from additional flexural/tension bars, closed ties and diagonal bars.



# Blast Design – Diagonal Tension (Shear)

- Single leg stirrups or lacing; use stirrups wherever allowed.

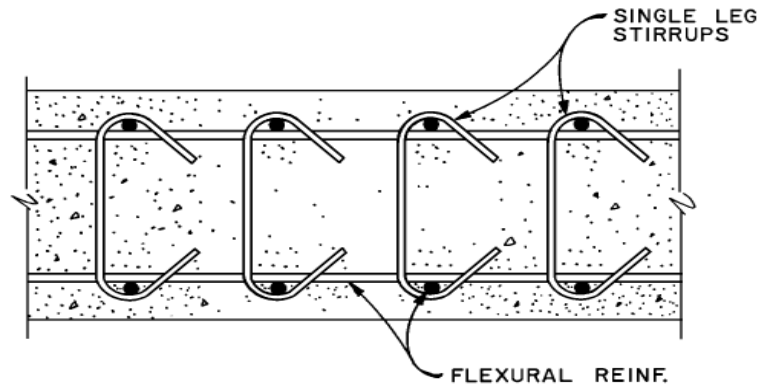
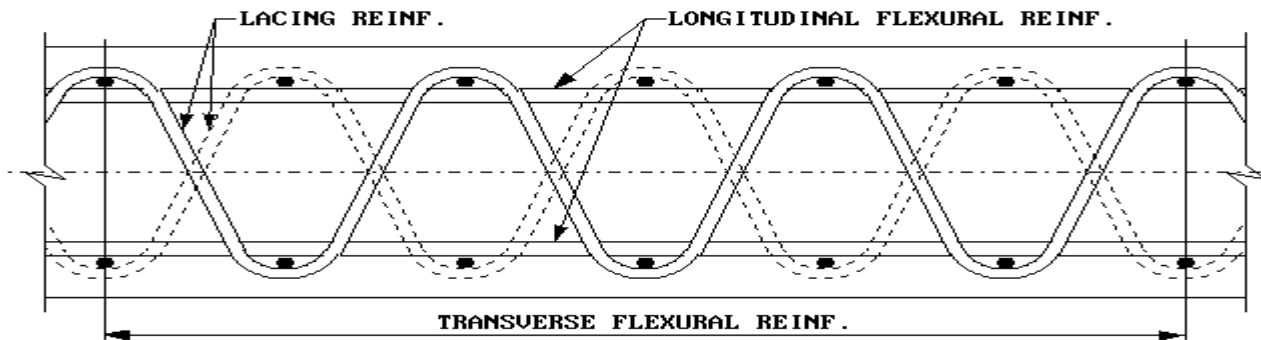

Figure 4-3. Lacing reinforcement





# Blast Design – Diagonal Tension (Shear)

---

- Minimum diagonal tension reinforcement is required in any wall/slab that may be placed in tension under blast loading.
- If stirrups are used for diagonal tension reinforcement, the following requirements apply:
  - Maximum spacing:  $d/2$  or  $d_c/2$
  - Stirrup required at each flexural bar intersection
  - Stirrups must hook around the outside flexural bar on each face
- Size elements to satisfy the foregoing requirements; for walls/slabs with 6-inch flexural bar spacing, recommended minimum thicknesses are:
  - 14-inches for Type I cross sections
  - 16-inches for Type II and Type III cross-sections
  - Increase foregoing thicknesses if wall/slab uses larger diameter flexural bars or if the required concrete cover exceeds  $\frac{3}{4}$ -inch (e.g., slab on grade or wall/slab exposed to weather)



# Blast Design – Direct Shear and Direct Tension

---

- Direct Shear
  - If a concrete wall/slab may be placed in tension under blast loading, all direct shear stresses must be taken by diagonal bars.
  - Diagonal bars take direct shear loads in tension or compression (place at 45 degree angle from wall/slab surfaces).
- Direct Tension
  - Required in single cell structures and end cells of multi-cubicle configurations.
  - Resist tension loads that may develop in walls/slabs under blast loading.
  - Reinforcing bars placed at mid-depth of wall/slab.



# Blast Design (Fragmentation Hazards)

---

- DoD 6055.09-M: When required, personnel protection must limit fragment energies to less than 58 ft-lbs (79 joules)
- DDESB Technical Papers (TPs) provide more detailed procedures for analyzing primary and secondary fragments
  - TP 13, “Prediction of Building Debris for Quantity-Distance Siting”
  - TP 16, “Methodologies for Predicting Primary Fragment Characteristics”
- UFC 3-340-02 provides curves/equations for assessing minimum concrete thicknesses to prevent spall and breach.
  - Curves/equations are empirical, so they apply only to tested configurations (e.g., cased explosives must be cylindrical in shape)
  - To use these curves/figures, other UFC 3-340-02 design and detailing requirements must be satisfied (e.g., stirrups must hook around outside flexural bars)





# Detailing and Construction

---

- Reinforcing bar detailers may not be familiar with UFC 3-340-02's detailing requirements. To avoid errors, structural design drawings should include details depicting wall/slab joints, pilasters along openings, and supplementary UFC 3-340-02 detailing requirements.
- Rebar shop drawings should be reviewed by an experienced blast designer, to verify both their accuracy and their constructability.
- Consider use of 4-inch concrete working pads.
- The design team and the construction contractor should meet during the preconstruction conference. At the meeting, the design team should review unique design and detailing requirements and explain recommended rebar installation and concrete placement methods for unusual/congested configurations (e.g., laced walls/slabs).
- If a construction contractor proposes substantive changes to a blast design, its proposal should be reviewed by the blast designer or by DoD/Service staff with explosives safety and blast design expertise.





# Conclusions

---

- Building layout is key, both to limiting potential exposures to blast effects and to reducing blast design requirements. On some design, significant savings may be realized by using corridors to separate remote explosives operating cells from the rest of a building.
- Whenever possible, the Services should fund personnel with explosives safety and blast design experience to review funding requests and to participate in design charrettes.
- Avoid configurations/exposures that are outside the scope of DDESB approved blast analysis and design procedures (e.g., UFC 3-340-02, TP 13, TP 16, etc.).



# Conclusions

---

- Consider constructability throughout the blast design process.
  - Retain some flexibility in room dimensions and wall/slab thicknesses.
  - As design proceeds, consider potential rebar installation and concrete placement issues in more congested areas (e.g., wall/slab joints).
  - Avoid interior wall openings for doors and equipment, particularly if the personnel or property requiring protection may be directly behind the wall during remotely controlled explosives operations.
- Questions?