



Presented to:

**21st Annual NDIA Systems &
Mission Engineering Conference**

***ERS is the Catalyst for
Collaboration between
Industry and
Government in Aviation
System Modeling***



DISTRIBUTION A. Approved for public release:
distribution unlimited. PR 4160

TECHNOLOGY DRIVEN. WARFIGHTER FOCUSED.

Presented by:

David J. Quinn

**Chief, Simulation & Aerodynamics Branch
U.S. Army Aviation and Missile Research,
Development, and Engineering Center**

Wednesday 24 October 2018



AMRDEC Mission



Deliver collaborative and innovative aviation and missile capabilities for responsive and cost-effective research, development and life cycle engineering solutions.

TECHNOLOGY DRIVEN. WARFIGHTER FOCUSED.

~9,211
FY17 Strength



2,945
Civilian

16
Military

6,250
Contractor

907 / 5343

SETA Non-SETA

Core Competencies

- Life Cycle Engineering
- Research, Technology Development and Demonstration
- Design and Modification
- Software Engineering
- Systems Integration
- Test and Evaluation
- Qualification
- Aerodynamics/ Aeromechanics
- Structures
- Propulsion
- Guidance/Navigation
- Autonomy and Teaming
- Radio Frequency (RF) Technology
- Fire Control Radar Technology
- Image Processing
- Models and Simulation
- Cyber Security

FY17
\$2,904M

6%
Aviation S&T

7%
Missile S&T

63%
Army

24%
Other

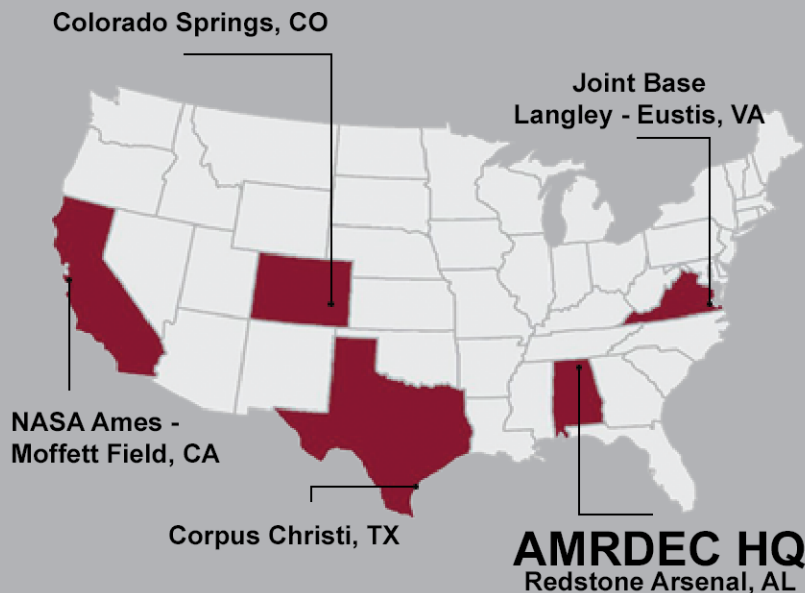



#1: Readiness

Provide aviation and missile systems solutions to ensure victory on the battlefield today.



#2: Future Force

Develop and mature Science and Technology to provide technical capability to our Army's (and nation's) aviation and missile systems.

#3: Soldiers and People

Develop the engineering talent to support both Science and Technology and the aviation and missile materiel enterprise





Presentation Outline



- Role of Modeling & Simulation and Digital Engineering in Acquisition
- Role of AED
- Introduce the Gray Eagle aircraft and General Atomics-ASI
- ERS: the Catalyst for the collaboration
 - OEM
 - AED
 - PM-UAS
- CREATE-AV : Kestrel
- Motivation: Streamlining the Acquisition Process
 - Common tools, common methods, common model
- Aerodynamic Modeling Project Overview: US Army AED / GA-ASI Collaboration
- Impact to the Government and OEM

This is a collaboration success story fostered by ERS.

- Exciting time to be in Modeling & Simulation
 - Mature tools and models are credible - Reflect reality with confidence
 - Models are necessary because the systems are so COMPLEX, requiring models to define them; too big for one SME to be responsible for understanding all facets of the design
- Emerging reliance on Digital Engineering for acquisition support
 - Impact of Digital Engineering on the acquisition process has been demonstrated
 - FVL FLRAA AoA Support: Early phase acquisition
 - Cargo Mission Analysis: PDR, CDR and Milestone B Decision

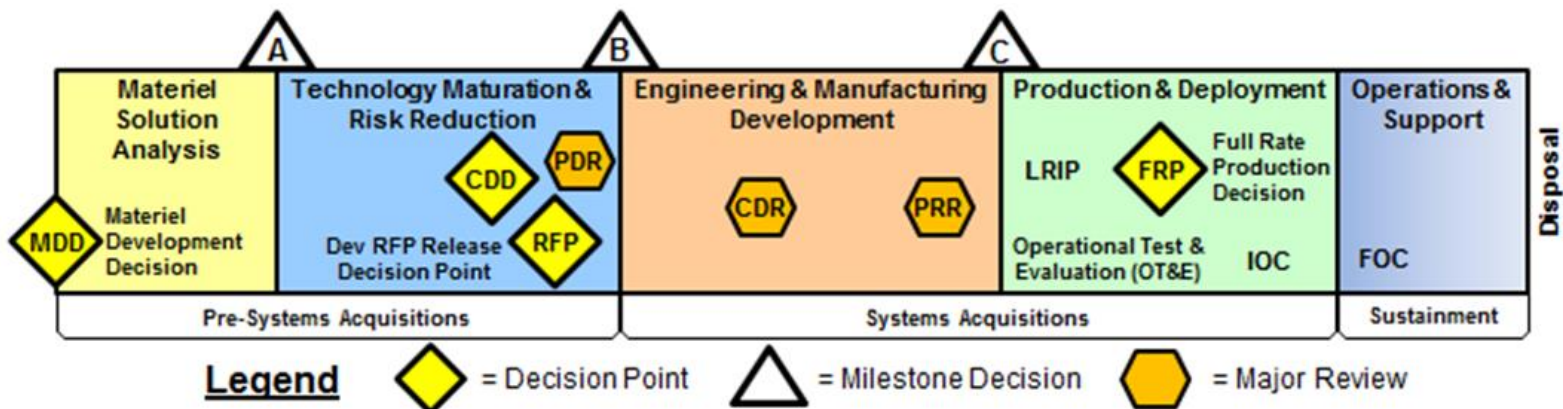



Role of AED

- AED is the delegated **Airworthiness Authority** for all Army Aviation assets
- Providing Airworthiness and **Acquisition** support to the PMs
 - Support throughout the system life cycle (earlier the better)
 - Requires cognizance of aircraft, processes and latest technology

Mission: Deliver responsive airworthiness solutions throughout the system life cycle. Sustain the leadership and engineering expertise necessary to provide valued products to our aviation customers.

Vision: The Aviation Engineering Directorate will be a Soldier-focused, world-recognized leader in airworthiness and aviation engineering, and the strategic partner of choice of the Army Aviation materiel enterprise.



General Atomics - ASI Gray Eagle UAV



General Atomics Aeronautical Systems

PowerPoint_Template_page_2012.png

**Predator A
Piston
(In Production)**



**Predator B/C
Turboprop/fan
(Production/Dev)**



**Small/Large
UAVs
(In Dev)**



2

This document does not contain U.S. export controlled technical data.



Source: NDIA Systems Engineering 2017 presentation, GA-ASI.

TECHNOLOGY DRIVEN. WARFIGHTER FOCUSED.



Traditional Interchange



OEM

**Aerodynamics Expertise
and Cognizance of the
Aircraft.**

PM UAS

**Lifecycle Manager of
Gray Eagle**

AED

**Experts with aero analysis
tools, Airworthiness &
Acquisition processes
across the Enterprise.**



ERS is the CATALYST



ERS is a combination of people, processes, and tools working together to streamline the integration of technological innovations into credible acquisition models that can then support digital engineering across the lifecycle of the system.

TECHNOLOGY DRIVEN. WARFIGHTER FOCUSED.

- **Common tools, common methods, common model**
 - All parties understand fundamental assumptions and methods
 - Streamlines the assessment of model credibility by the airworthiness authority (US Army AED)
- **Identify and solve issues collaboratively**
 - Reduces RISK for everybody (collective understanding)

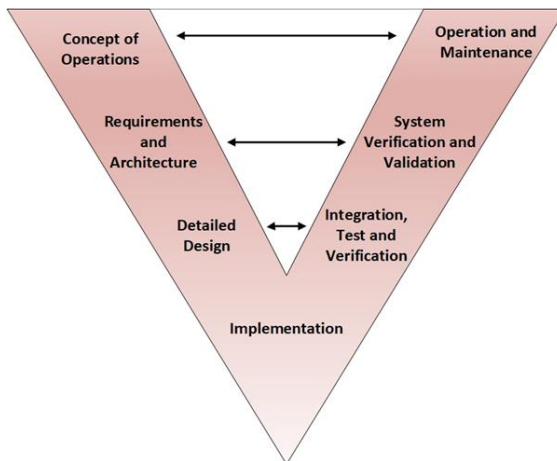

- **Other platform examples:**
VV&A process with Chinook rotor model, and Flight Performance / Mission Analysis models

Streamline acquisition of aircraft through Collaboration

Kestrel is the fixed-wing product of the DoD HPCMP CREATE™-AV program

- Born from requirements gathered in 2007/8 to address modeling & simulation deficiencies in the DoD acquisition process
- Multi-mesh/multi-solver paradigm
 - Unstructured near-body
 - High order Cartesian off-body
 - Adaptive Mesh Refinement (AMR)
 - Fast overset connectivity
- Full spectrum of aircraft type
 - Fighter, Bomber, Tanker, Transport, UAV
- Full spectrum of flight conditions/missions
 - Low-speed, transonic, supersonic
 - Cruise, maneuver, take-off/land, refueling, formation flight, store carriage and release, pilot ejection, precision air-drop, and more...



Kestrel Version 9

Capabilities

High fidelity coupled physics

- Aerodynamics
- Structural Dynamics
- Propulsion
- Flight Control Systems

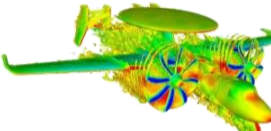

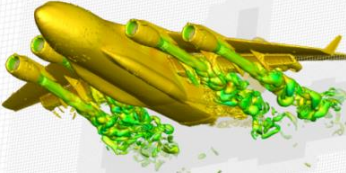

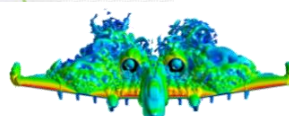

Key Technologies

- Multi-mesh paradigm
- High order, adaptive Cartesian solver
- Event-driven infrastructure
- Multi-language data warehouse
- Generalized interface for externally-developed “plug-in” capability

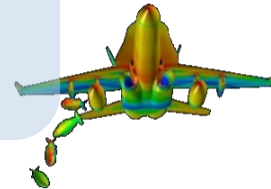





Expanding Footprint of Kestrel Adoption

- Over 600 active license holders
- Over 20 Defense Orgs (Labs, Engineering and Test Centers) actively using Kestrel
- All major manufacturers actively evaluating Kestrel
- Multiple organizations affiliated with Other Federal Agencies using Kestrel to support US Gov't Programs
- Several select US Academic Institutions and the Service Academies using Kestrel to support DoD Programs



Aerodynamic Model Project Overview



- **Aircraft Scan & Geometry Alignment: Assessment**
 - PM-UAS funded the scan of an as-built Gray Eagle, coordinated by AMRDEC S3I Aero
- **Conversion of Scan to CFD Geometry**
- **Common Modeling Techniques Development**
 - **Surface Meshing Guidelines**
 - **Boundary Layer & Volume Meshing Guidelines**
- **Kestrel Model Development and Validation Effort**
- **Propeller Modeling**

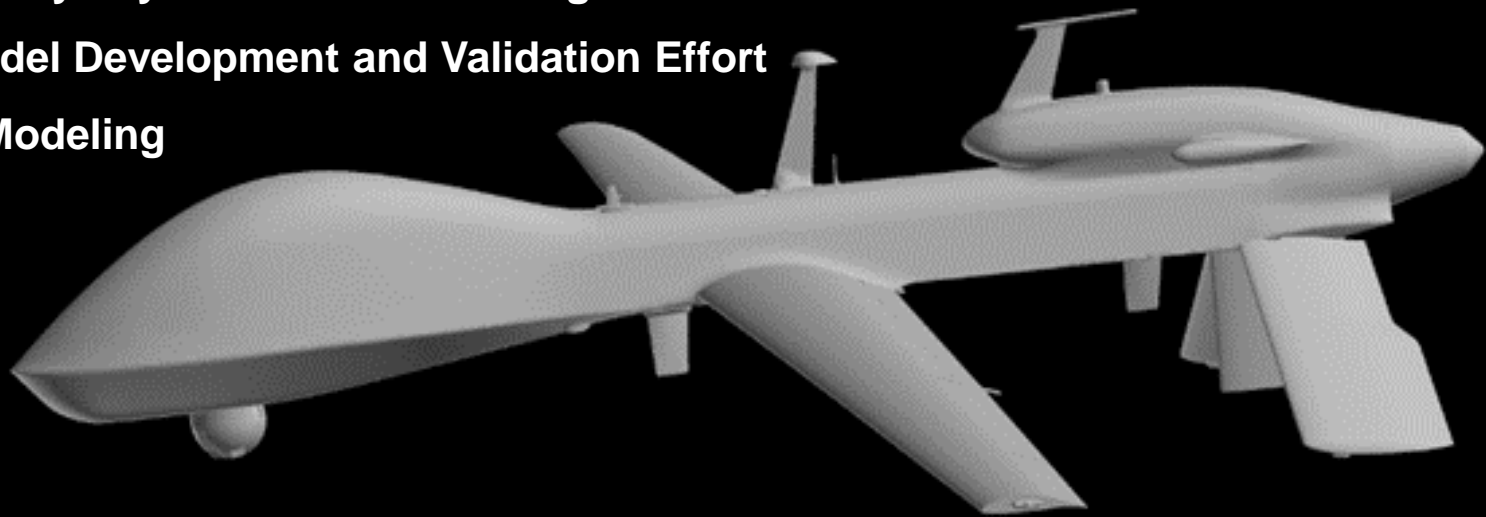

Enabling the Development of Flight Performance Calculation tools



Gray Eagle – CFD Model Development

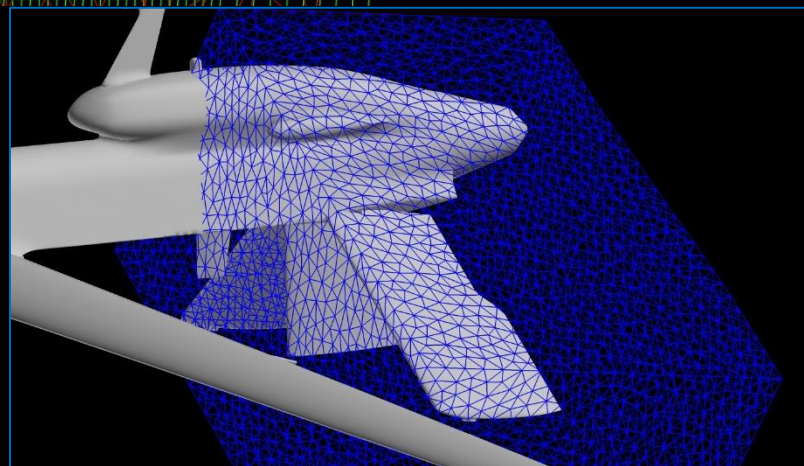
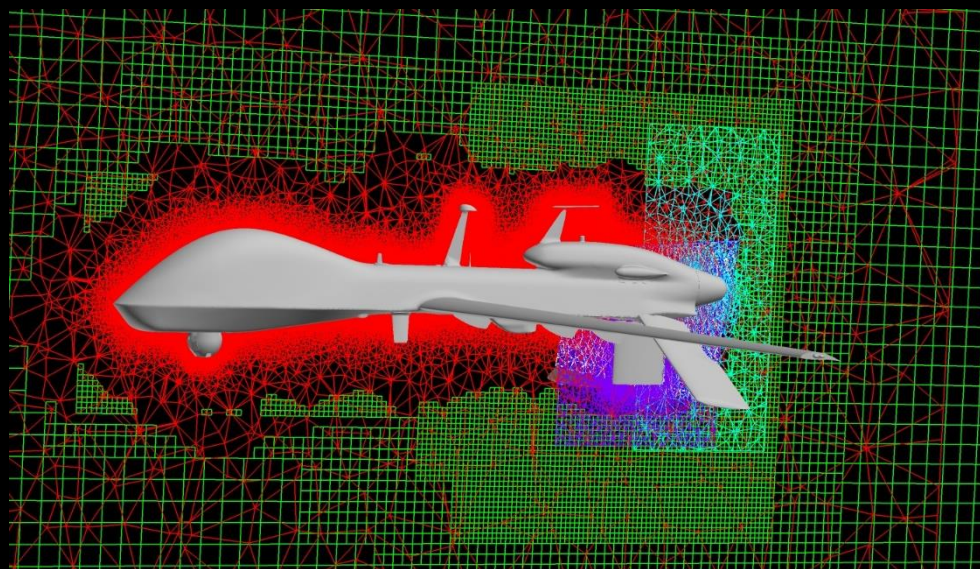

- **CFD Solutions:**
 - Using Kestrel
 - Overset
 - Near-Body Unstructured Grids
 - Off-body Cartesian Grids
- **Configurations:**
 - Gray Eagle – Clean – Rigid Wings
 - Gray Eagle - With Antenna – Rigid Wings
- **Movable Surfaces**
 - Stabilators
 - Rudder
- **Grids**
 - Near-Body: 20 million points (56 million cells)
 - Off-Body: 2.2 million points



Gray Eagle Aero Model

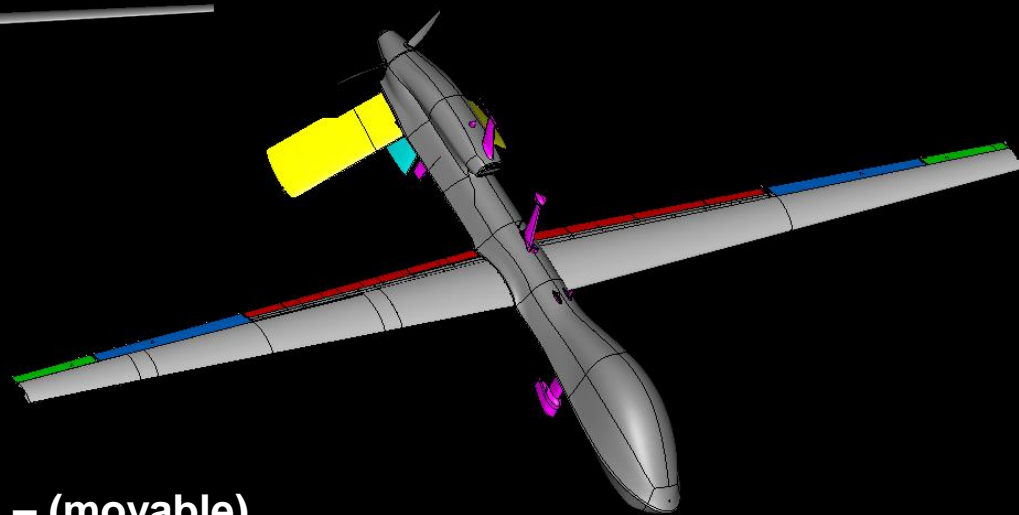
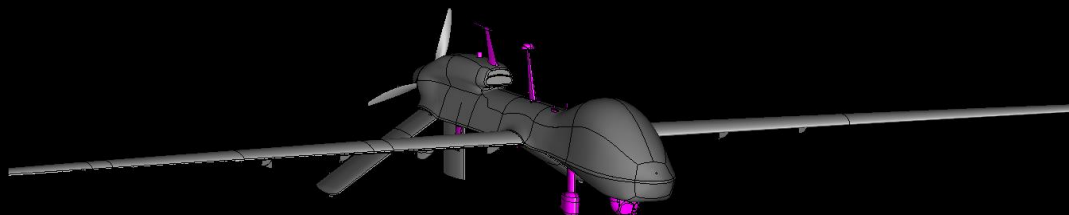

Included:

- **Control Surfaces:**
 - Flaps (2) – (landing/loiter)
 - Inboard/ Outboard Ailerons (4) – (movable)
 - Stabilators (2) (movable)
 - Rudder (1) (movable)
- Antenna (9+)
- Landing Gear - Stowed/Extended

- Independent evaluation of the aircraft scan quality
- Insight to the OEM's methods and assumptions
 - Aerodynamic analysis techniques, guidelines
 - How modeling is used in overall aircraft analysis
(modeling augments Wind Tunnel testing, Flight Testing, etc.)
- Development of a High-Fidelity aerodynamic model profiting from the technical synergy of two advanced engineering groups
- Capability to confidently predict flight performance impacts of configuration modifications using engineering tools

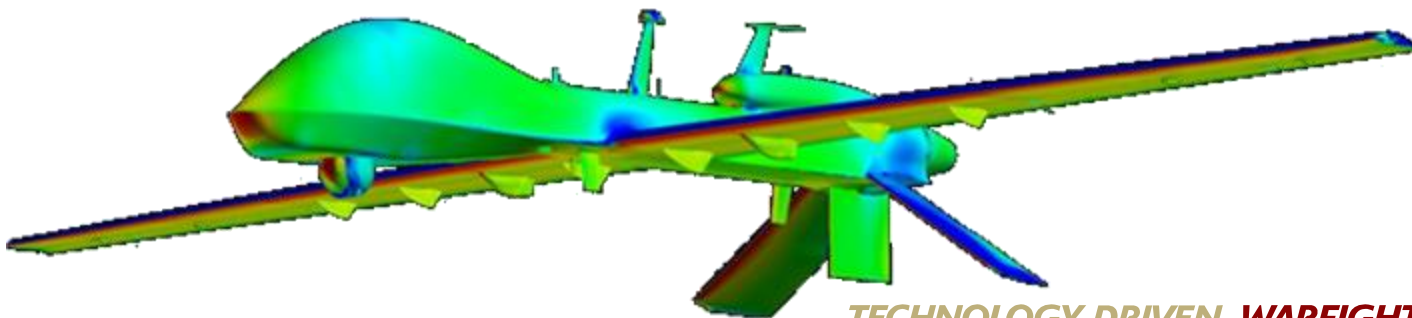

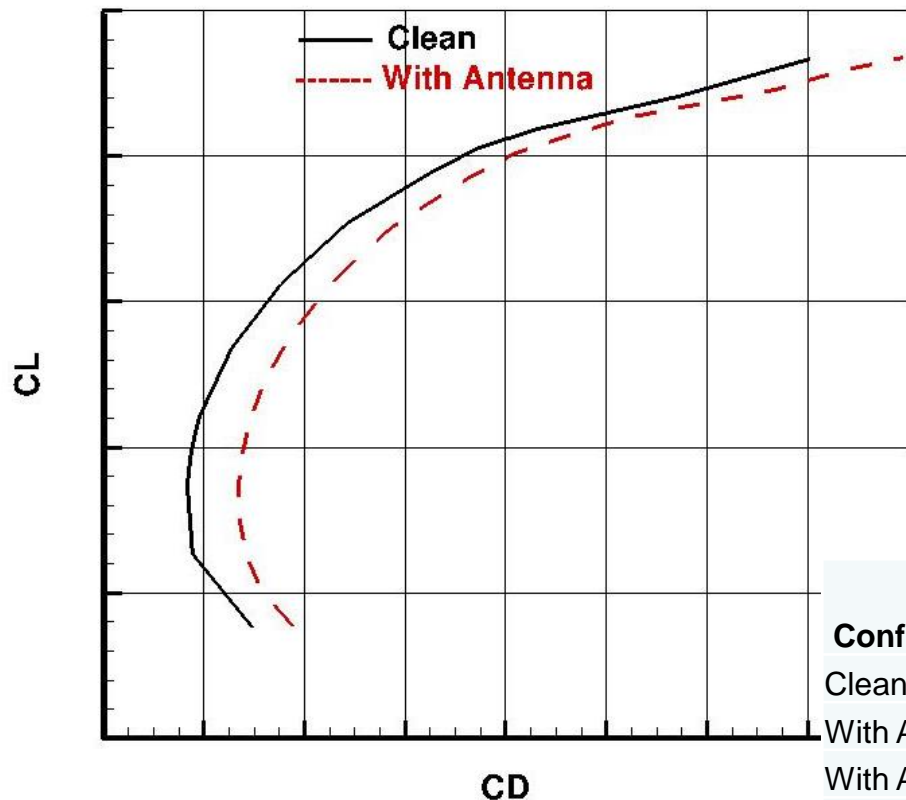

Analyze the aerodynamic effects and flight performance impact of modifications to the aircraft configuration.

- Climb capability
- Time on Station
- Range
- Max. Airspeed
- Best Airspeed

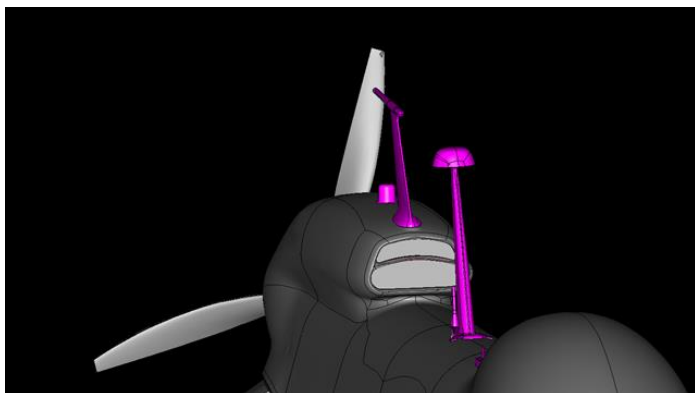

Configuration	Alpha	Beta	Stabilators		Number of Runs
			Left	Right	
Clean	A1	0	0	0	21
With Antenna	A2	0	0	0	29
With Antenna	0	B1	0	0	21
With Antenna	A3	0	-15	-15	17
With Antenna	A3	0	-10	-10	17
With Antenna	A3	0	-5	-5	17
With Antenna	A3	0	5	5	17
With Antenna	A3	0	10	10	17
With Antenna	A3	0	15	15	17
Total					173

- Developed expertise in CREATE-AV Kestrel
- Use of Army High-Performance Computing, HPC resources (BIG enabler)
- Access to Army techniques & airworthiness evaluation processes
- Development of a High-Fidelity aerodynamic model profiting from the technical synergy of two advanced engineering groups

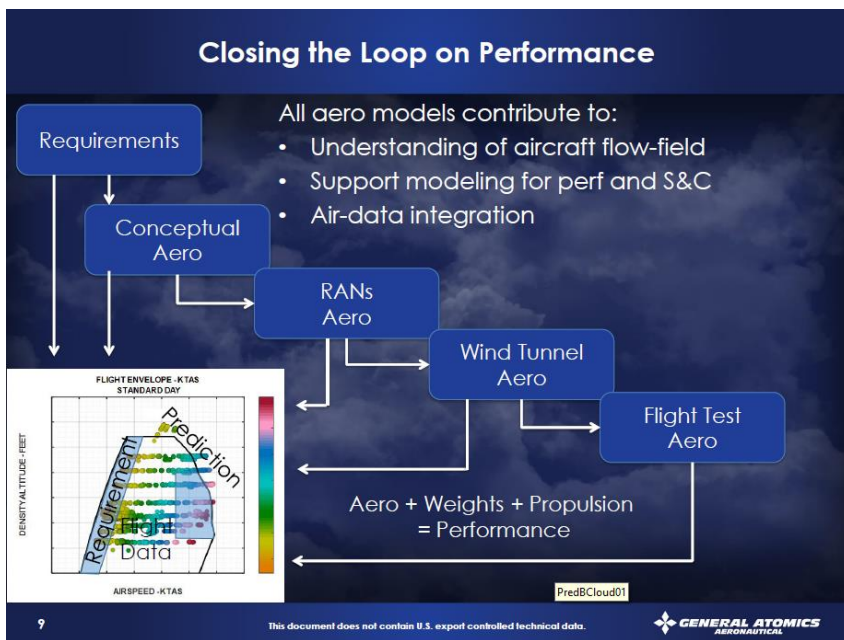

Source: NDIA Systems Engineering 2017 presentation, GA-ASI.

TECHNOLOGY DRIVEN. WARFIGHTER FOCUSED.

Collaboration success story fostered by ERS

1. Synergy yielded technical achievements not possible without CREATE-AV Kestrel, HPC resources and ERS.
2. Streamlining acquisition process for future Gray Eagle modifications
3. For Future Vertical Lift efforts, this modeling capability provides baseline representation of a current Army UAS to be used for modernization efforts.





AMRDEC Web Site
www.amrdec.army.mil

Facebook
www.facebook.com/rdecom.amrdec

YouTube
www.youtube.com/user/AMRDEC

Twitter
@usarmyamrdec

Public Affairs
AMRDEC-PAO [@amrdec.army.mil](mailto:AMRDEC-PAO@amrdec.army.mil)