



Guided Munitions for Aerial Gunnery; Increased Mission Effectiveness and Large Cost Savings

L. Schumacher¹

R. Barrett²

¹ PhD Student, University of Kansas

² Professor of Aerospace Engineering
Adaptive Aerostructures Laboratory Director

National Defense Industrial Association
62nd Annual Fuze Conference, 2019



- Introduction
 - Guided Hard Launch Munitions (GHLM)

- Concept of Operations

- Aerial Applications
 - F-15
 - FAC-130
 - F-35

- Future Work



M712 Copperhead 1975

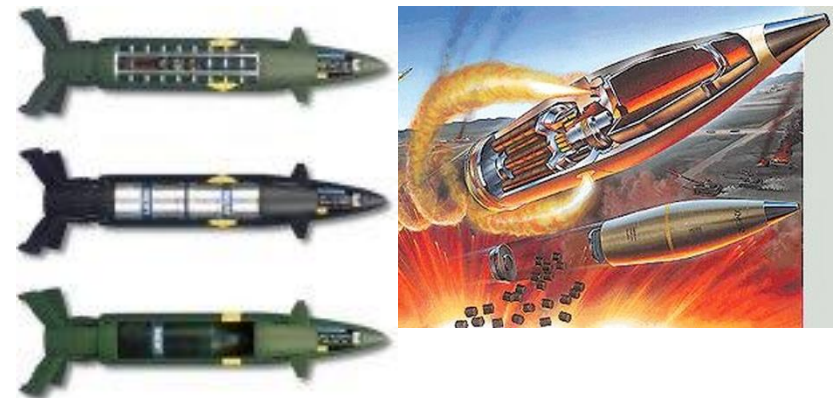

XM 982 Excalibur & ERGM



Barrel-Launched Adaptive Munition (BLAM) Program 1995 - '97

USAF/AFRL-MNAV

- Aerial Gunnery (20 - 105mm)
- Extend Range w/2g maneuver
- (Eglin AFB tests '97)
(Mach 3.3 tests '96-'97)
- Increase hit probability
- Increase probability of a kill given a hit
- Reduce total gun system weight fraction

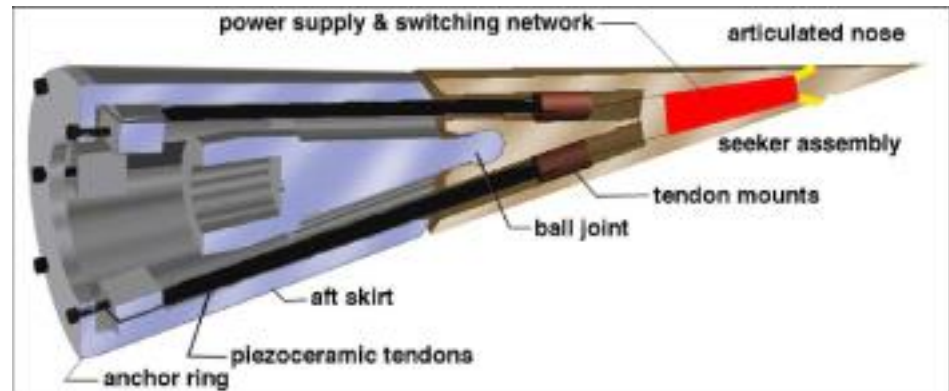



AAL: Building Adaptive Actuators for Hard-Launch Munitions since 1995

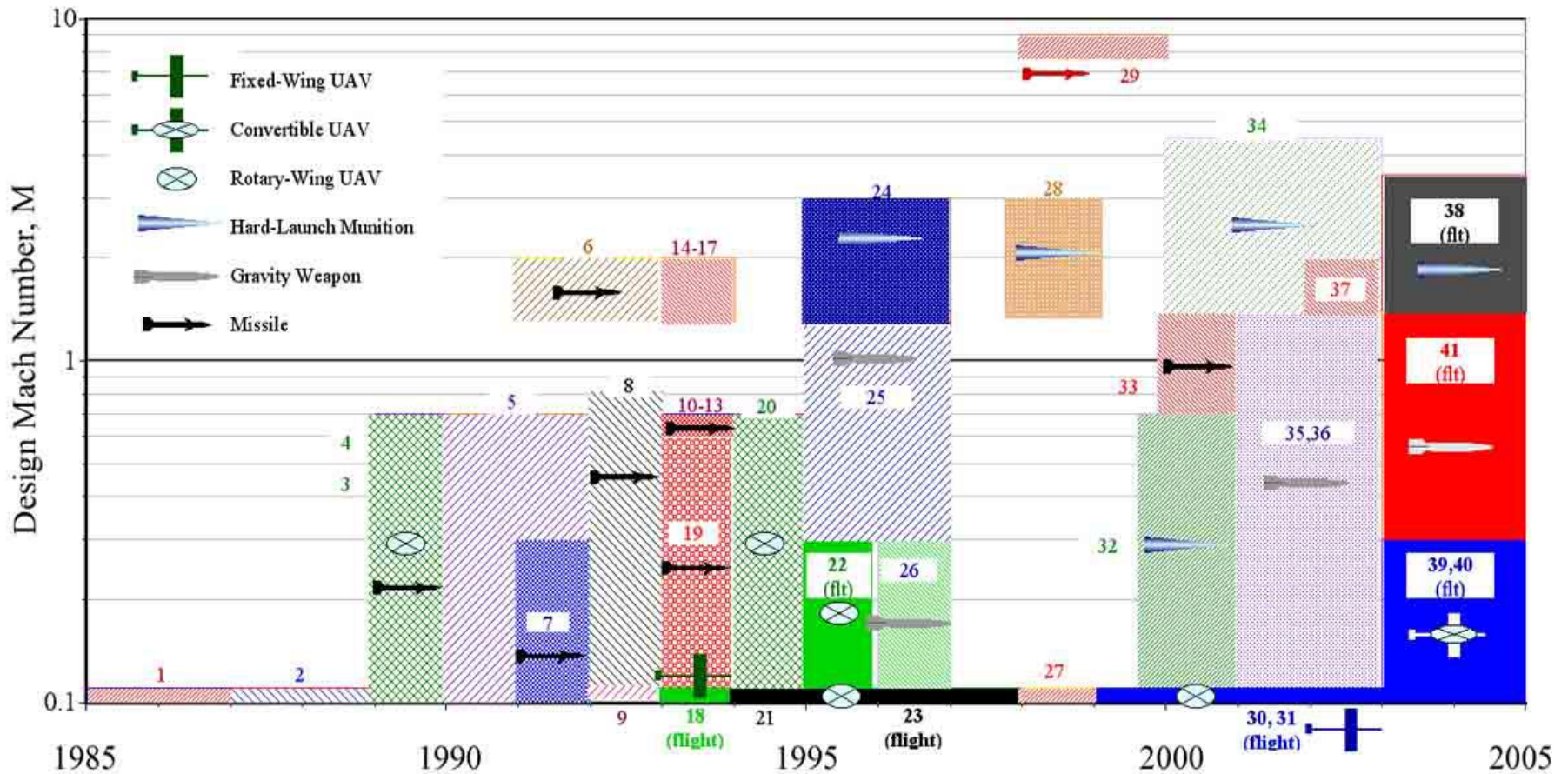



- Copperhead: 155mm, USA Armament Research
 - 1970's indirect fire against hardened targets
- Adaptive Guided Munitions Programs
 - Barrel Launched Adaptive Munition (BLAM), 1995, conical round, USAF Armament Directorate
 - Hypervelocity Interceptor Test Technology (HITT), 1998, USA Space and Missile Defense Command
 - Range-Extended Adaptive Munition (REAM), 1998, sniper round, derivative—SCREAM, USA Armament Research, Development, and Engineering Center
 - Light Fighter Lethality Adaptive Round (LFLAR), subsonic, USA Armament Research
- Extended Range Guided Munition (ERGM), Raytheon
 - Rocket Assisted Projectile (RAP), 5 in diameter, 13-54nmi (Cancelled)
- Extreme Accuracy Tasked Ordnance (EXACTO), DARPA
 - DARPA initiative, small caliber guided sniper round, live fire tests in 2015
- M982 Excalibur, Raytheon
 - 155mm GPS and inertial guided munition for close-support
- Multi-Azimuth Defense Fast Intercept Round Engagement System (MAD-FIRES), DARPA
 - DARPA initiative, medium caliber guided rounds



AAL: Issued patents & 2 decades of test data up to: Mach 11, 1kHz, 100,000g's

PBP-Class Hard-Launch Capable Full-Proportional Actuator FCS Units:

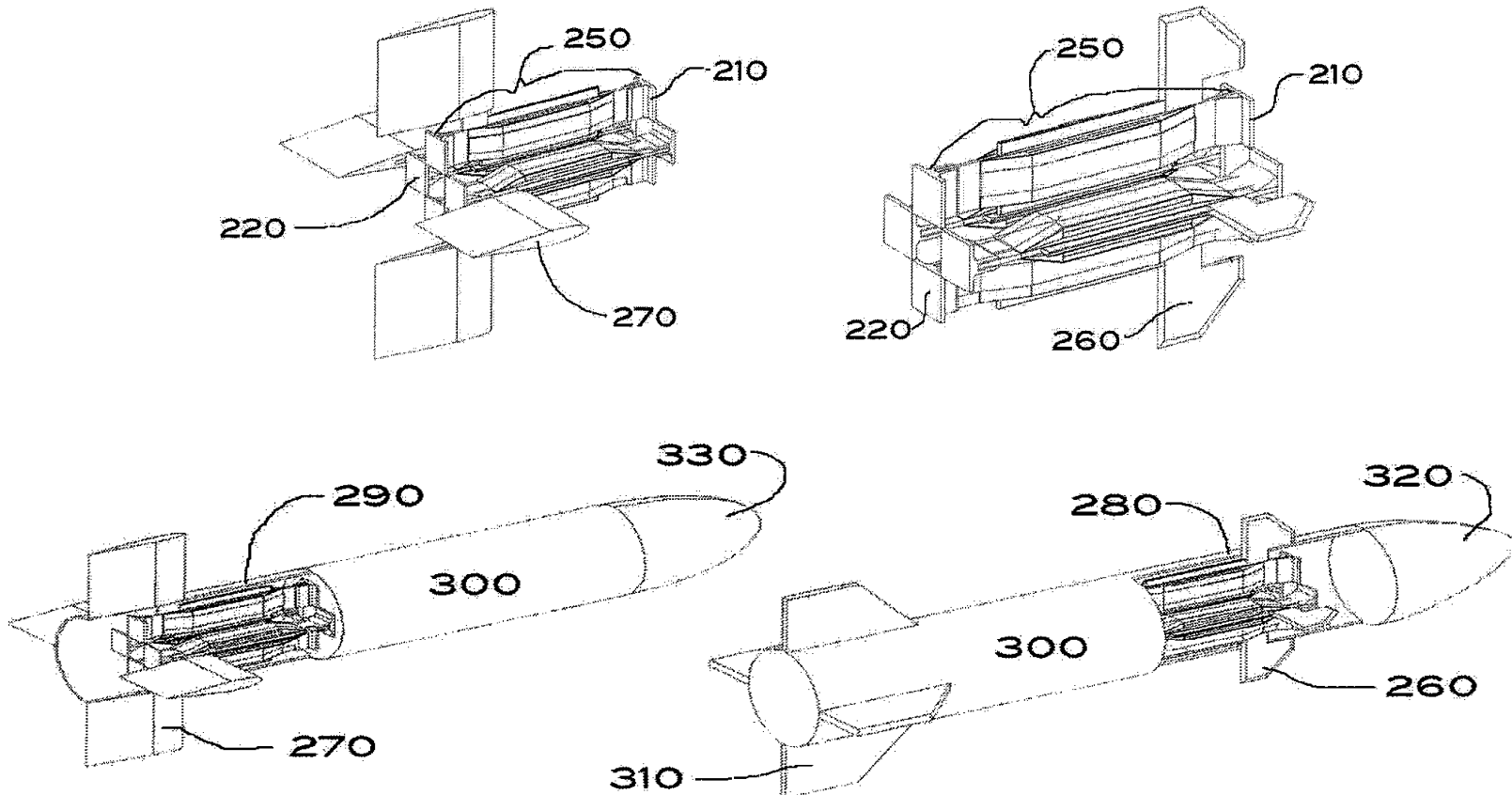



- Increased Number of Targets
- Expanded Engagement Range Envelope
- Airframe Defense with Maneuver Overmatch
- Decreased Cost per Kill

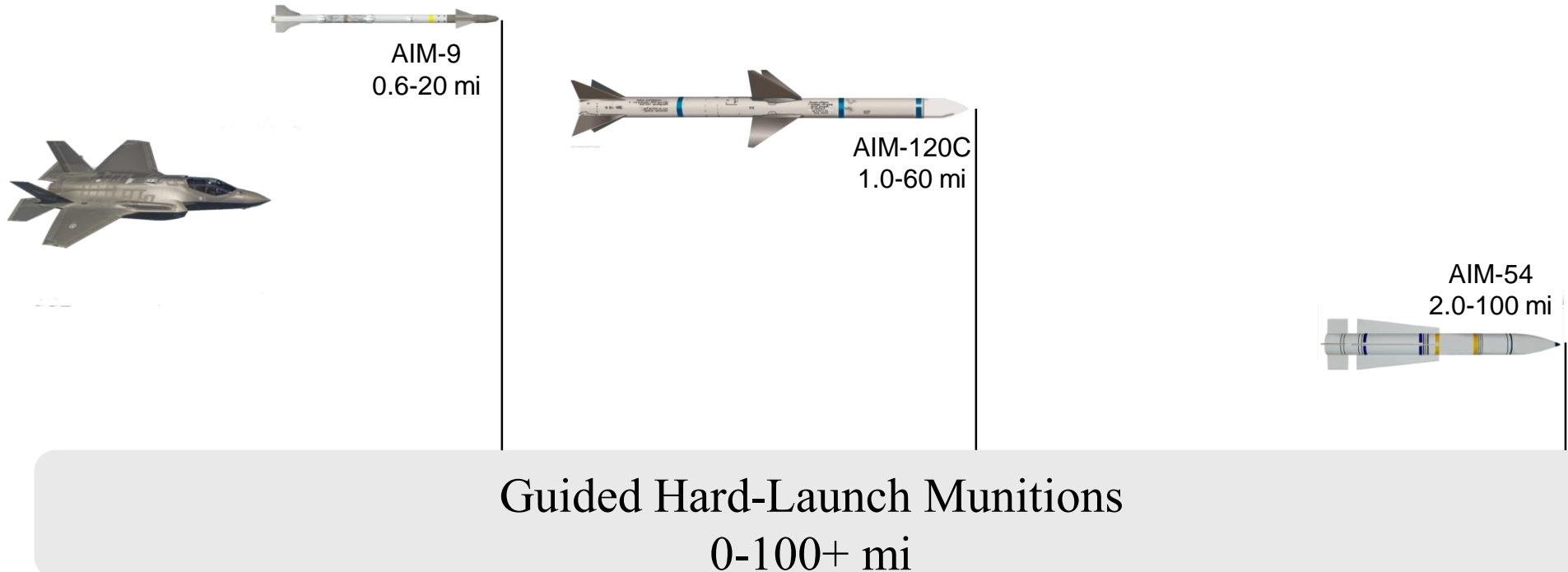



- Reduced Observables (RF, IR & Acoustic)
- Increased Airframe Performance
 - Reduction in platform weight, wetted area, and total volume



[1]



[2]



- Energy based analysis: interior and terminal ballistics
- 6 DOF ballistic model
- Simplified intercept in simulated atmosphere

$$\Phi_w(\omega) = \frac{2\sigma_w^2 L_w}{\pi V} \frac{\left(1 + \frac{8}{3} * \frac{2.678 L_w \omega}{V}\right)^2}{\left(1 + \left(\frac{2.678 L_w \omega}{V}\right)^2\right)^{\frac{11}{6}}}$$

$$\frac{d\bar{V}}{dt} = -\frac{\rho V S C_D}{2m} \bar{V} + \frac{\rho S C_{L\alpha}}{2m} (V^2 \hat{x} - (\bar{V} \cdot \hat{x}) \bar{V}) + \bar{g}$$

$$\frac{d\bar{h}}{dt} = \frac{\rho V S d^2 C_{lp}}{2I_y} (\bar{h} \cdot \hat{x}) \hat{x} + \frac{\rho V^2 S d \delta_F C_{l\delta}}{2I_y} \hat{x} + \frac{\rho V S d C_{M\alpha}}{2I_y} (\bar{V} \times \hat{x})$$



➤ Increase impact kinetic energy at Effective Range:

➤ PGU-14 $E_{\text{impact}}/E_{\text{muzzle}} \sim 51\%$

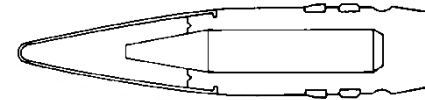

➤ MASS GHLM $E_{\text{impact}}/E_{\text{muzzle}} \sim 89\%$



➤ MASS Guided Variants





- MASS Guided Indirect Fire
 - Semi-ballistic path
 - Terminal Guidance

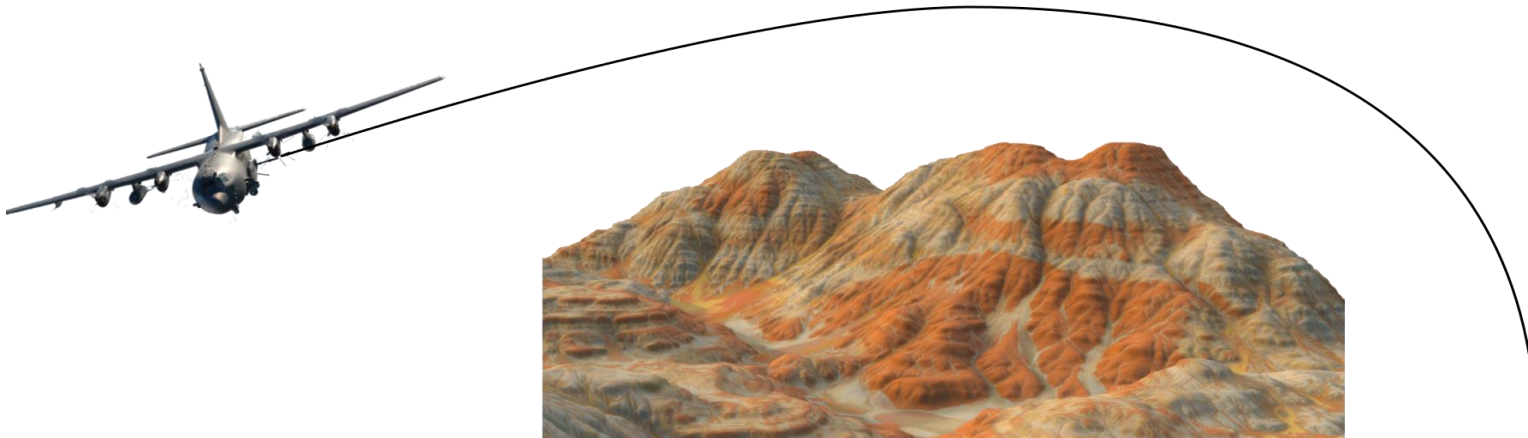



- MASS GHLM IR defense
 - Flying “flare”
- MASS GHLM RF defense
 - Kinetic kill
 - Proximity with debris field





➤ Maneuver Specification

➤ Simulated R-77 intercept

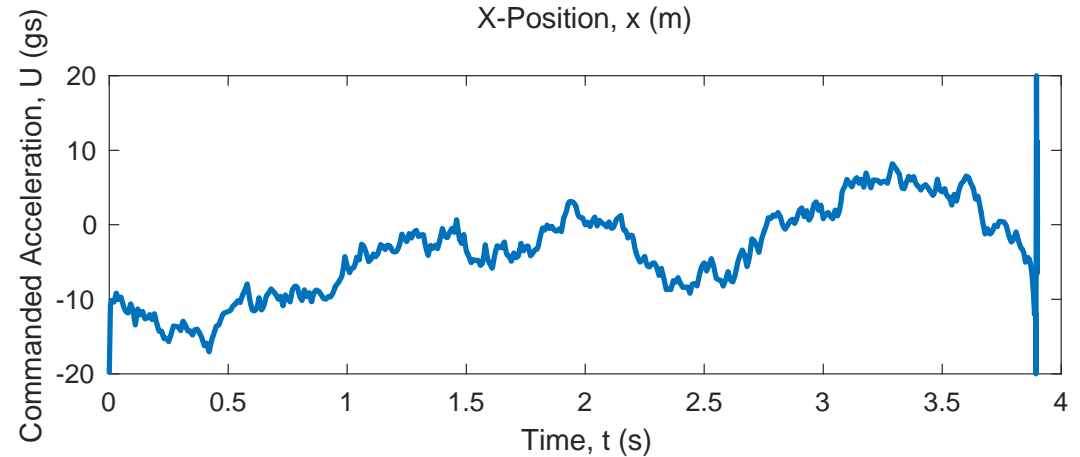
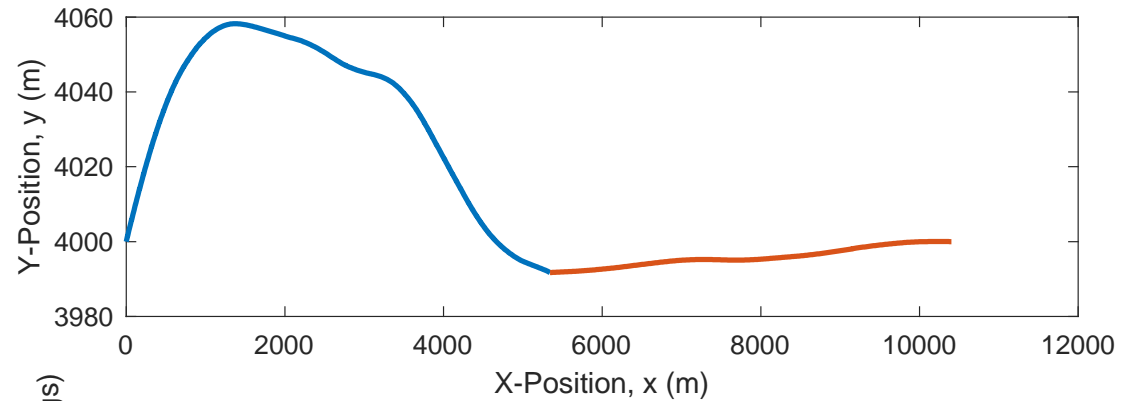
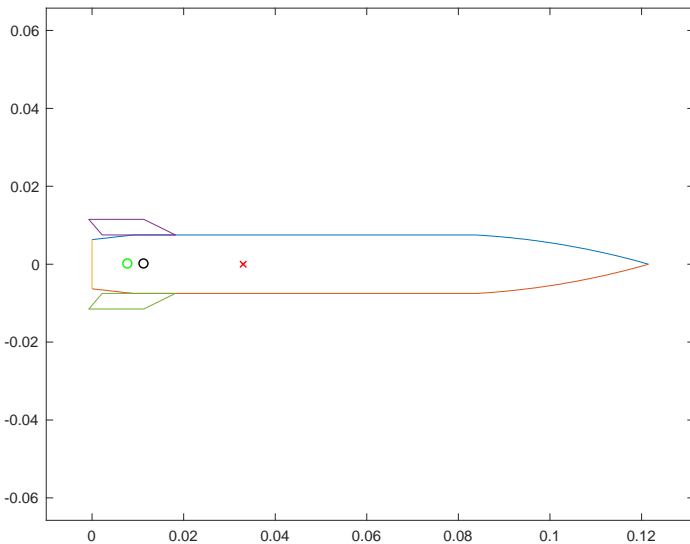



➤ P_k estimation

➤ Cost/kill of MASS GHLM < conventional missile

➤ Miss radius estimation

$$N = \frac{\ln(1 - P_{k,desired})}{\ln(1 - P_{k,projectile})}$$

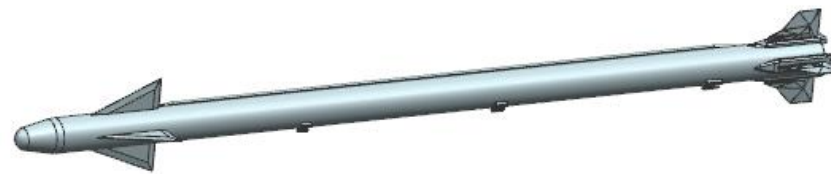
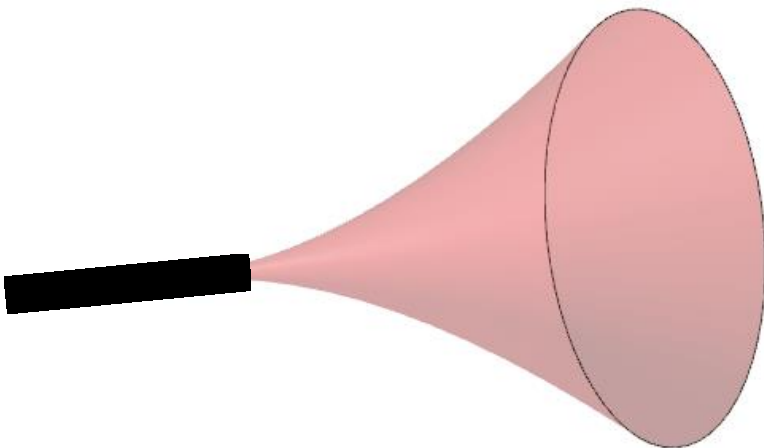

$$V_{fragment} = \sqrt{2E} \left(\frac{m_{metal}}{m_{charge}} + \frac{1}{2} \right)^{-\frac{1}{2}}$$



➤ Existing Loadout

- 4 x AIM-9
- 8 x AIM-120
- 940 x 20mm



[4]

➤ M61 Vulcan retrofit



[5]



➤ Simulated retrofit PGU-28 series:

➤ Direct fire near sea-level

	PGU-28 A/B	20mm MASS GHLM	% Change
Projectile Mass (kg)	0.11	0.11	~
Effective Range (mi)	1.28	1.90	+48%
Ballistic Coefficient (PGU reference form factor)	1.03	1.87	+81%

➤ Indirect

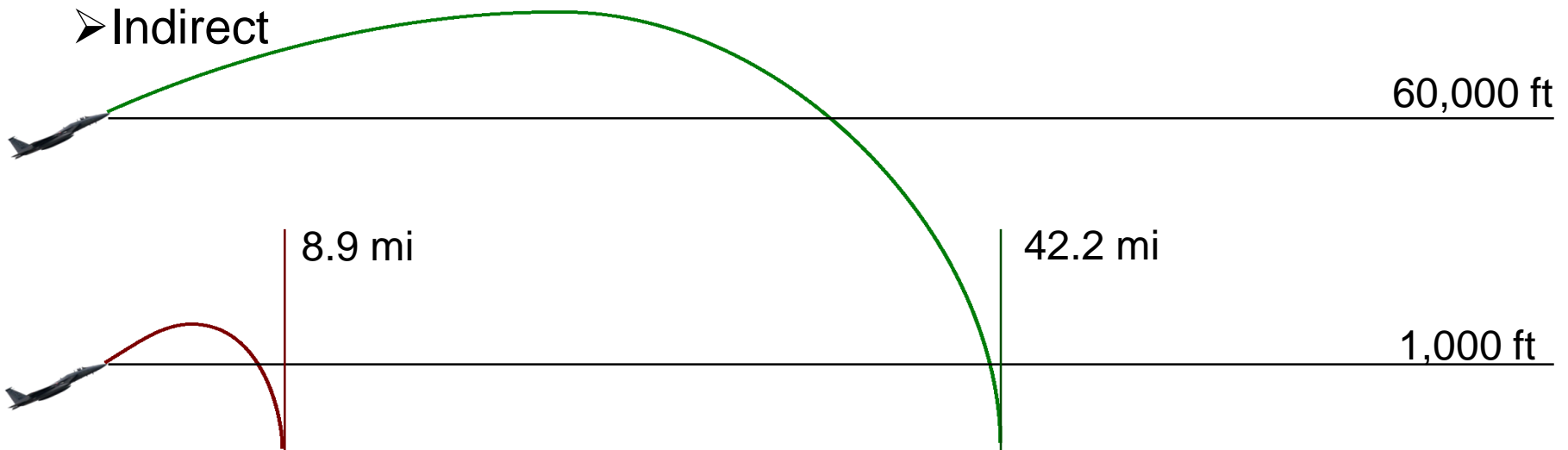



➤ Existing Loadout AC-130U Spooky II

- 1 x 25mm GAU-12/U
- 1 x 40mm L/60 Bofors
- 1 x 105mm M102

➤ M102 retrofit



[6]



➤ Simulated retrofit M1 series:

➤ Direct fire near sea-level

	M1	105mm MASS GHLM	% Change
Projectile Mass (kg)	18	18	~
Kinetic Energy at Impact (kJ)	607	788	+30%
Ballistic Coefficient (M1 reference form factor)	2.34	3.81	+63%

➤ Indirect

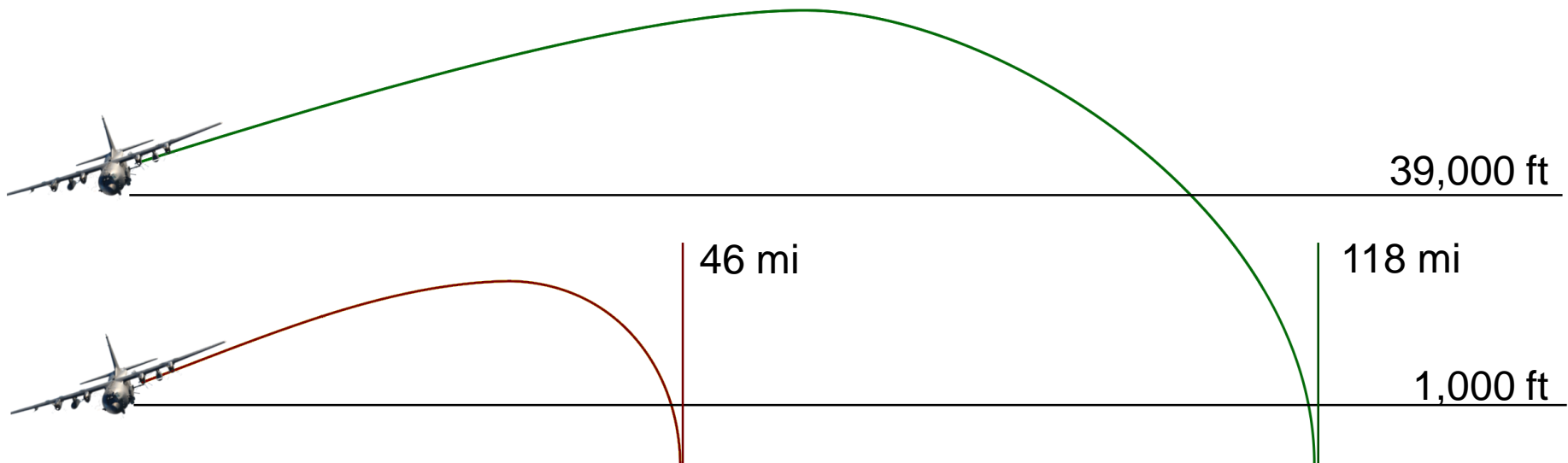



➤ Existing Loadout F-35A

➤ 14 x AIM-120

➤ 2 x AIM-9

➤ 180 x 25mm

➤ GAU-12/U retrofit



[7]



➤ Simulated retrofit PGU-25 series:

➤ Direct fire near sea-level

	PGU-25	25mm MASS GHLM	% Change
Projectile Mass (kg)	0.18	0.18	~
Effective Range (mi)	1.42	2.19	+54%
Ballistic Coefficient (PGU reference form factor)	1.26	2.10	+67%

➤ Indirect

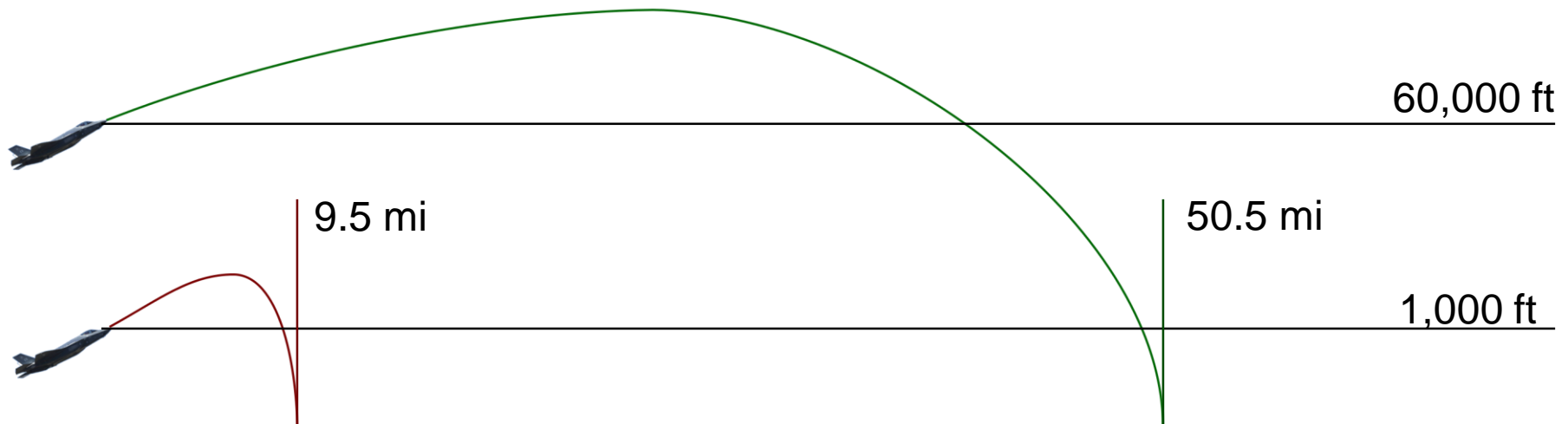



➤ F-35A vs GHLM Equipped Fighter (XF-36)

- AAA code used for both aircraft, then scaled based on known F-35A procurement cost per airframe. Assumed 1768 airframes at uniform price

Program Level Costs (\$ billions)		
	F-35A	XF-36
RDT&E Total	\$25.5B	\$13.6B
Manufacturing Cost (Program)	\$110.4B	\$82.2B
Acquisition Cost	\$115.9B	\$86.3B
Program Operating Cost	\$235.5B	\$225.5B

Airframe Level Costs		
	F-35A	XF-36
Unit Price (millions)	\$ 80.0M	\$ 56.5M
Operating Cost per Flight Hour	\$ 29,600	\$ 28,400



MASS Guided Hard Launch Munition Potential on Aerial Platforms

- Ranges comparable to modern air-to-air missiles
- Expanded engagement range envelope
- Increased number of targets engaged
- Effectively increase caliber of aircraft without retrofit of gunnery system
- Implications for airframe defense and future aircraft design
- Reduced cost/kill
- Enhanced survivability and more rounds allow fewer aircraft to carry out the same mission



Enabling Technology: MASS

- Secure commercial partner for MASS tech. transfer
- Work with commercial partner to capture aerial munitions market



The University of Kansas
Department of Aerospace Engineering

The Madison and Lila Self Graduate Fellowship



1. *Lockheed Martin F-35 Lightning II*. [image] Wikipedia. Available at: https://en.wikipedia.org/wiki/Lockheed_Martin_F-35_Lightning_II [Accessed 26 Apr. 2019].
2. User: Constantinos P. *Lockheed Martin F-35 Lightning II test jet AF-1 testing various CAS loadouts, and external stores*. [image] Pinterest. Available at: <https://www.pinterest.com/pin/441986150906582417/> [Accessed 26 Apr. 2019].
3. Merrill III, J. A. (2018). "What is the distance that the sabot of an APFSDS actually separates from the initial projectile being fired out of the barrel," [image] Quora. Available at: <https://www.quora.com/What-is-the-distance-that-the-sabot-of-an-APFSDS-actually-separates-from-the-initial-projectile-being-fired-out-of-the-barrel> [Accessed 26 Apr. 2019].
4. Rogoway, T. (2015) "This is a Fully Armed F-15SA, The Most Advanced Production Eagle Ever," *Eagles* [image] Foxtrot Alpha. Available at: <https://foxtrotalpha.jalopnik.com/this-is-a-fully-armed-f-15sa-the-most-advanced-product-1715732294> [Accessed 26 Apr. 2019].
5. User: Sunburst 68. (2012) "M61 Vulcan Gatling Gun," [image] Flickr. Available at: <https://www.flickr.com/photos/62798159@N04/7373874858> [Accessed 26 Apr. 2019].
6. Ritsick, C. (2019) "Lockheed AC-130U Spooky II Shows Off Its Power," *Aircraft* [image] MilitaryMachine. Available at: <https://militarymachine.com/ac-130u-spooky-ii/> [Accessed 26 Apr. 2019].
7. Short, M., "F-35 Weapons Suite | F-35 Lightning II," *Lockheed Martin*, 2016. [image] Available at: <https://www.f35.com/media/photos-detail/f-35-weapons-suite/> [Accessed Jul. 2016].



Questions