



PROJECT MANAGER FORCE PROJECTION

PM Force Projection Robotics Update NDIA Robotics Capabilities Conference & Exhibition 25 April 2019

LTC Jon Bodenhamer
PdM Applique and Large
Unmanned Ground Systems



PEO CS&CSS Robotics Portfolio

PEO CS&CSS

S&T Lead

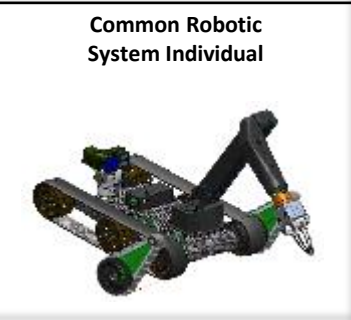
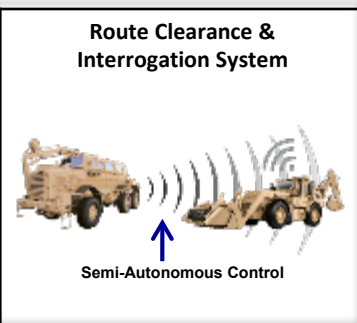

* Images are conceptual representations, not endorsements



Squad Multipurpose Equipment Transport (SMET)

Description: 80 systems (20 each GD, ARA, HDT, H&H) issued to Soldiers in 2 IBCTs for a 6 month Technology Demonstration to evaluate performance and operational impact

Two Configurations: Unmanned and Optionally Manned

Required Capabilities:

- Carry 1000 pounds
- Operate over 60 miles in 72 hrs
- Power Generation of 3KW stationary and 1KW moving

Objective Requirements and Modular Mission Payloads

<ul style="list-style-type: none"> • Full Autonomy • Enhanced Commo • Waypoint Navigation • CASEVAC 	<ul style="list-style-type: none"> • Silent Watch • Universal controller compatibility • Dems (Lane Clearing and Interrogation) • Lethality (CROWS/PLWRWS) 	<ul style="list-style-type: none"> • Enhanced CBRNE Sensing • Imbedded Video TMs and Manuals • ISR suite
---	--	---





Modular Mission Payload Assessment Event



Event

- Location
 - Ft. Benning, GA
- Date
 - 22-26 April 2019
- Duration
 - 1 week



Overview

Demonstrate

- Phase II Contractor MMP products
- Government Projects:
 - R2V2 – TARDEC
 - DEMS – CERDEC
 - RWS – ARDEC
 - CASEVAC – MEDCOM
 - CBRNE – JPEO CB
- Examples:
 - Enhanced Comms
 - Enhanced Sensing
 - Autonomy
 - Lethality

Contracting Strategy

- Through current Phase II OTA each vendor will demonstrate their current MMP designs
- MEDCOM, CERDEC, & JPEO CB are all participating at no cost
- 1144 with TARDEC & ARDEC for minimal costs

Stakeholders

- RAS CDID
- TCM-IBCT
- FORSCOM
- MCOE
- MsCOE
- USMC

Benefits

- Inform the SMET CPD with MMP requirement
- Assess MMP TRL levels
- Evaluate vendor payload options
- Formalize SMET IOP hardware interface and power requirements



Route Clearance & Interrogation Systems Type I



Mission: The RCIS Type I protects Soldiers performing excavation, interrogation, and classification of deep buried IEDs, explosive hazards and caches. It enables the ability to neutralize explosive hazards. Soldiers semi-autonomously control HMEE from a protected stand-off position (minimum 200meters) inside a Buffalo vehicle.

Route Clearance & Interrogation Systems (RCIS) Type I provides Tele-operation and an optional RADAR-based Follow-Me capability, LIDAR obstacle detection, onscreen predictive turning map, & customizable camera views, using commercial-based technology integrated to a legacy Army platform. It is modular and can be adapted to other systems

RCIS Type I Provides:

- Soldier protection while performing threat interrogation
- Ability to neutralize explosive hazards from a stand-off position up to 200 m
- Modular, robotics capability from tele-operation to Follow-me semi-autonomy
- RADAR-Based follow-me technology for route clearance convoy ops
- Teleoperation for excavation of suspected hazards
- On-screen predictive mapping
- LIDAR-based obstacle sensing
- Customizable camera views

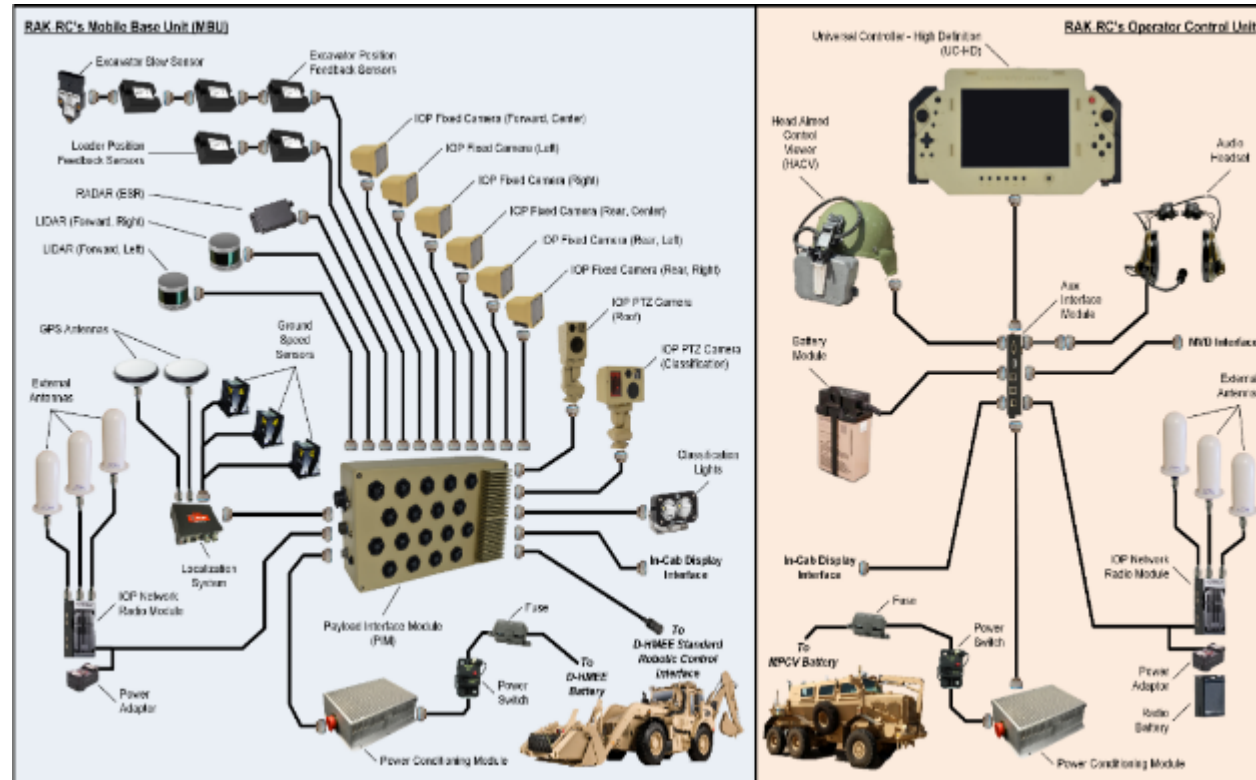



PLS A1 Leader Follower Capability

System Description: The Leader Follower capability is a suite of robotic applique sensors and vehicle by-wire and active safety upgrades to provide an unmanned capability to the PLS A1 Fleet of vehicles for convoy operations. Fully developed sensor and autonomy kit will be compatible with majority of Army line haul truck and trailer fleet.

TWV-LF Capabilities:

- Increase Line Haul Company daily convoy mission capacity.
- Force protection and logistics throughput for line haul convoy missions for the PLS Fleet of TWVs.
- Wirelessly link unmanned follower PLS' to a soldier operator Leader PLS vehicle.
- Reduces number of soldiers required to operate convoy, resulting in reduced number exposed to risk of injury from attack.

Near Term Major Events

- Contractor led, Government observed testing at Ft. Bliss Jan – May 2019
- ATEC testing to support Technology Demonstration Testing start Jun 2019



- **Acquisition Category (ACAT): III Pre-MDD**
- **Acquisition Objective (AAO/APO): 4566/3300**
- **Capability Production Document (CPD):
Estimated AROC in 4QFY2020**
- **Full Material Release: TBD**



MTRS Inc II Program Overview / Update

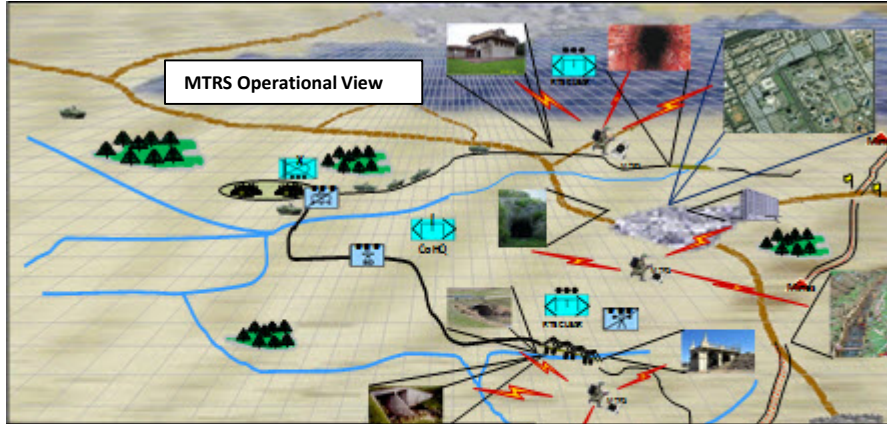

- The Man Transportable Robotic System (MTRS) Inc II is a remotely operated, man-transportable, robotic system
- Provides a standoff capability to interrogate, detect, confirm and neutralize presence across War-fighting functions
- Capability to identify and disposition explosive hazards
- Army's medium sized common platform allowing use of various platform payloads in support of current and future missions

* AAO includes EOD requirement of 587

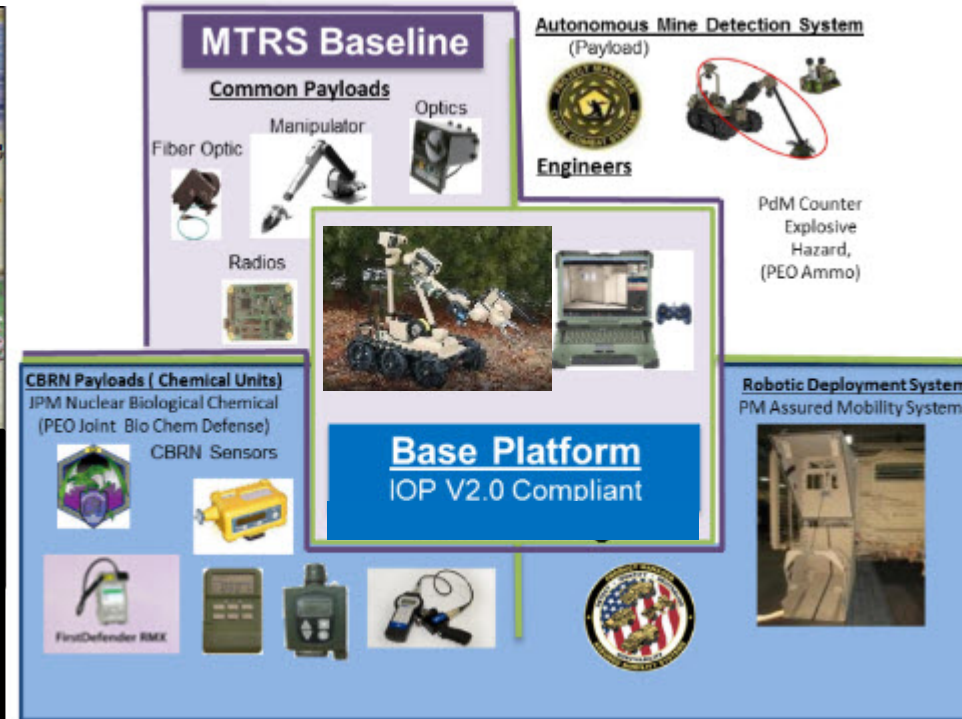

- ✓ **CPD: Approved, MAY 2013**
 - ✓ **Contract: Awarded, SEP 2017**
 - **First Unit Equipped (FUE): 2QFY20**
- AAO: 1,210**
- Users: Engineer, CBRN, EOD and SOF**



Common Robotic System (Individual) {CRS(I)}



System Description: The CRS(I) is the Army's small sized (<25 lbs), common platform, remotely operated and Soldier back-packable robotic system providing Soldiers dismounted increased standoff capability from hazardous threats. The system consists of a Universal Controller (UC), a suite of payloads, an open architecture common mobility platform allowing for future capability growth.

Capabilities:

- Standoff short range Intelligence, Surveillance, & Reconnaissance (ISR)
- Remote Chemical, Biological, Radiological, and Nuclear (CBRN) detection
- Remote Explosive Obstacle Counter Measure (EOCM)
- Remote Explosive Ordnance Disposal (EOD) operations
- Remote clearance of danger areas
- UC with ability to control battalion and below unmanned system PORs

- ✓ **CDD: Approved, 5 JAN 2016**
- ✓ **Milestone B: 2QFY18**
- ✓ **Milestone C: 2QFY19**
- First Unit Equipped 2QFY20
- AAO: 3,258
- APO: 690
- Users: INF, CBRN, ENG and EOD

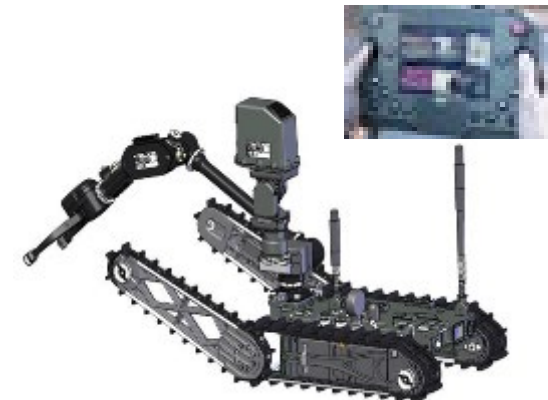
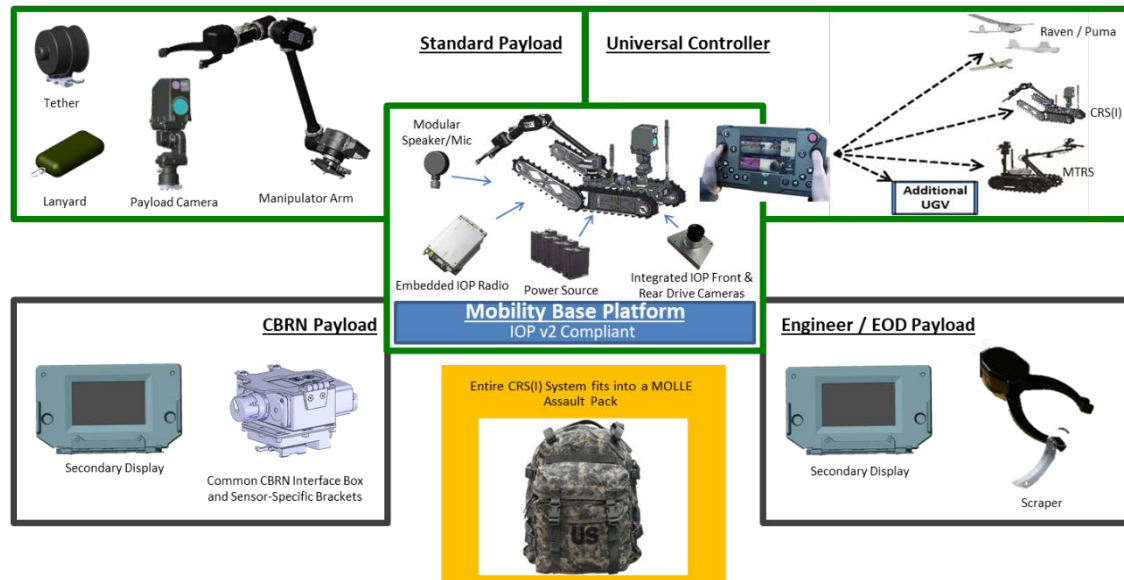

QinetiQ
North America

LRIP contract awarded to QinetiQ North America on 11 March 2019



Common Robotic System Heavy (CRS(H)) Program Overview

Fly-Off #2 In Process

System Description:

The CRS(H) is the Army's large sized, vehicle transportable, common robotic platform capable of accepting various mission payloads enhancing protection to the EOD Soldier by providing increased standoff capability to identify, render safe and dispose of explosive ordnance and improvised explosive devices in support of the Range of Military Operations and Homeland Defense operations.

Performance Requirements:

- Manipulator Arm Lift Capacity (Close to Platform > 275 lbs; Full Extension (72 in) > 100 lbs)
- Platform Speed > 6 mph
- Obstacle Clearance > 32 in (New Jersey Barrier)
- Platform Endurance > 7 hrs
- Weight < 700 lbs curb weight, 1000 lbs gross system weight (includes 300 lbs of non-native payloads)
- Interoperability – IOP compliant & utilize Universal Controller
- Cyber Hardened

- ✓ CPD: Approved, May 2018
- ✓ Fly-Off Agreements (OTA) Issued: Aug 2018
- ✓ Fly-Off 2 In progress (25 Mar – 7 Jun 19)
- Production OTA projection award Aug 2019
- FUE: 2QFY20
- AAO: 248
- Users: EOD and CBRN

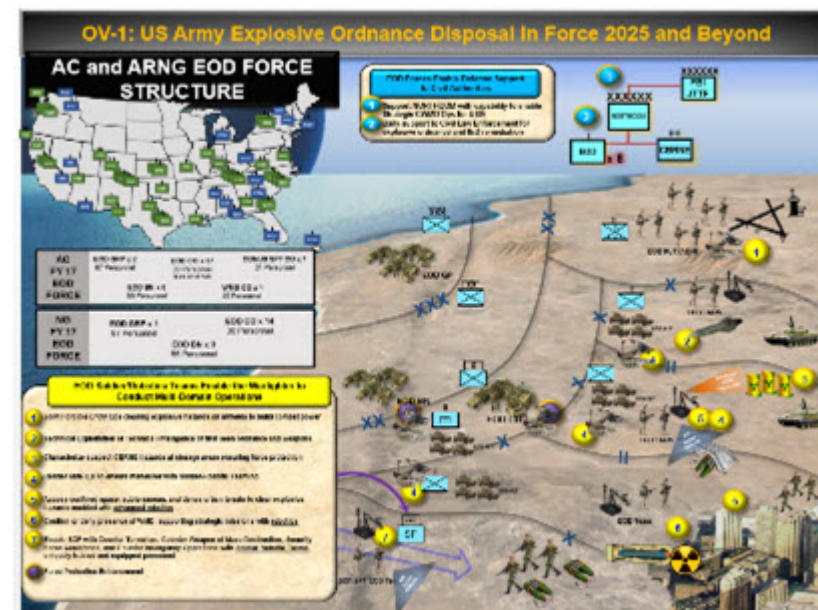
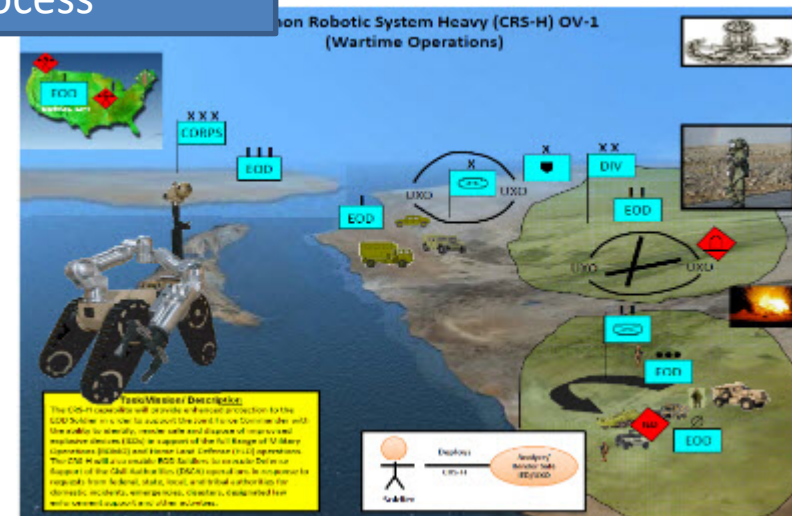

* Images are conceptual representations, not endorsements



Enhanced Robotic Payloads

CPD staffing initiated

System Description:

The ERP is a suite of modular capabilities designed with open architecture to provide an increased level of standoff, situational awareness, disruption capability and dexterity to respond to current and emerging Engineer, CBRN and EOD requirements. These multiple, modular robotic mission payloads will use open architecture to integrate with the MTRS Inc II and CRS(H) platforms to form the Army's next generation platform adaptable robotics systems.

Capabilities:

- Dual Arm Dexterity
- Multi-Shot Disrupter
- Fine Precision Aiming Module
- Multispectral Overlay Camera
- Obstacle Avoidance & Digital Modeling
- Extended Range Radio & Mesh Networking
- Extended Range UAV & Surveillance

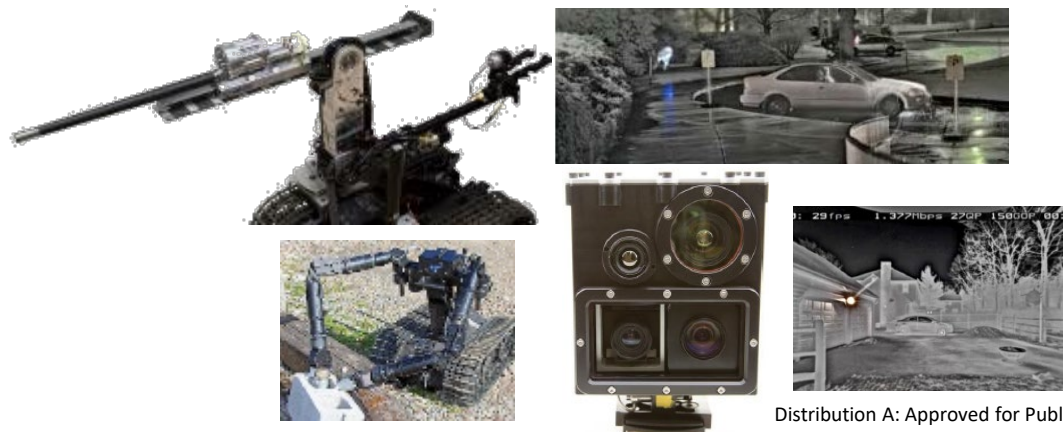

Distribution A: Approved for Public Release

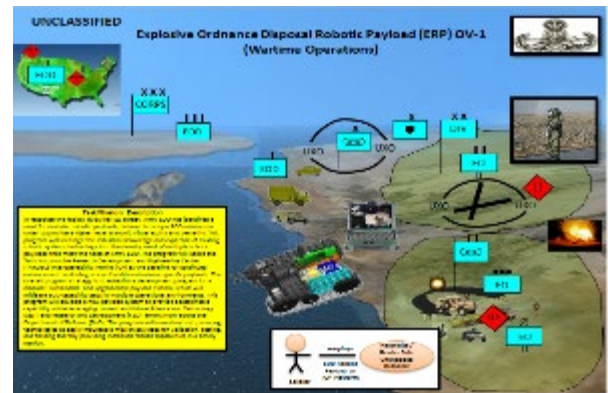

• CPD Approval: ~FY19
 • Solicitation Release: TBD
 Users: CBRN and EOD

* Images are conceptual representations, not endorsements



Robotic Enhancement Program Update

- REP defunded in FY20 and beyond to support higher priority Army efforts
- REP CoC 19.1 and prior approved initiatives to continue through completion
- Final REP initiative expected to complete in 2QFY20

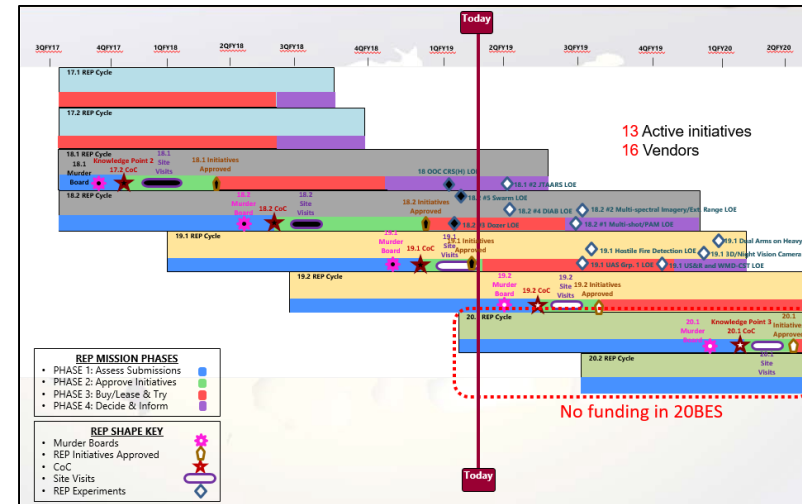
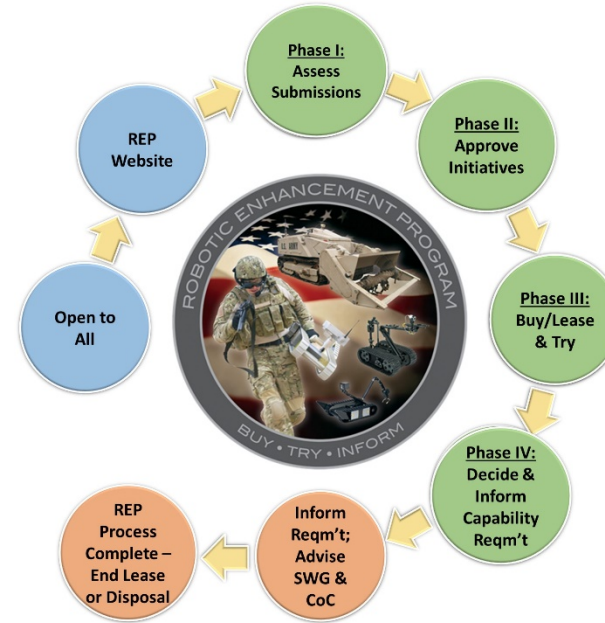



REP Accomplishments – 2015 – 2019

Through the support of the Robotics Industry, REP conducted (REP Cycles 16.1 - 18.2)

- 20 initiatives evaluated in operational environments:
 - Directly informing 14 capability documents (CPD, CDD, AoA)
 - Indirectly informing 19 capability documents indirectly informed (CDD, ICD, CPD)

– Accomplishments:

- CRS(H) - Eliminated a need for EMD Phase, accelerated acquisition by 10 – 12 months
- Universal Controller: Demonstrated maturity, reduced the EMD phase by 24 months
- SMET: Facilitated 1-Year Technology Demonstration, accelerated acquisition by 10 – 12 months with goal of first unit equipped within 24 – 36 months
- JTAARS: FUE pulled 48 months ahead
- Offensive Swarm: Provided feedback on challenges on communication bandwidth when utilizing multiple UGVs and UASs



Thank you for your support



Discussion